

(12) PATENT APPLICATION
(19) AUSTRALIAN PATENT OFFICE

(11) Application No. AU 199923549 A1

(54) Title
Radio telephone apparatus

(51)⁶ International Patent Classification(s)
H04Q 007/32 H04B 001/06

(21) Application No: **199923549**

(22) Application Date: **1999.04.01**

(30) Priority Data

(31) Number	(32) Date	(33) Country
10/091521	1998.04.03	JP

(43) Publication Date : **1999.10.14**

(43) Publication Journal Date : **1999.10.14**

(71) Applicant(s)
NEC Corporation

(72) Inventor(s)
Mitsuru Tanaka

(74) Agent/Attorney
SPRUSON and FERGUSON,GPO Box 3898,SYDNEY NSW 2001

-
.
.
.
.

RADIO TELEPHONE APPARATUS

ABSTRACT OF THE DISCLOSURE

5 A voltage control variable attenuator (20) takes a structure using a feedback loop which allows a signal modulated by a modulator (10) to be attenuated based on a comparison result from a comparator (70). A power amplifier (40) outputs the signal inputted thereto from the voltage control variable attenuator (20) without amplifying the signal when no control signal is outputted from a control section (7), and amplifies a
10 power of the signal inputted thereto from the voltage control variable attenuator (20) to output it when the control signal is outputted from the control section (7). In a detection circuit (50), a change-over switch (57) is provided which switches a detection voltage to be detected, depending on whether or not the control signal is outputted from the control section (7).



~~What is claimed is:~~

The claims defining the invention are as follows.

1. A radio telephone apparatus comprising:
 - an antenna for receiving and transmitting a radio wave;
 - receiving means for extracting a specified signal
5 from the received radio wave through the antenna;
 - transmitting means for transmitting information to be transmitted to an outside through said antenna; and
 - control means for outputting a control signal to lower a transmitted output of said transmitting means by a
10 specified amount, thereby controlling the transmitted output of said transmitting means,
 - wherein said transmitting means comprises:
 - modulation means for modulating a signal to be transmitted through said antenna;
 - 15 variable attenuating means for attenuating the signal modulated by the modulation means based on a control voltage inputted and outputting the attenuated signal;
 - amplifying means for directly outputting the signal inputted from said variable attenuating means when said
20 control signal is outputted from said control means, and amplifying a power of the signal inputted from said variable attenuating means to output the amplified signal when said control signal is not outputted from said control means;

25 detection means for demodulating the signal inputted
from said amplifying means, and detecting a detection
voltage by different circuits depending on whether or not
the control signal is outputted from said control means,
based on an output of said control signal from said control
30 means;

reference voltage generating means for generating
different reference voltages depending on whether or not
the control signal is outputted from said control means,
based on an output of said control signal from said control
35 means; and

comparing means for comparing said reference voltage
with the detection voltage detected by said detection means,
thereby outputting a comparison result, and

wherein said variable attenuating means comprises
40 means for attenuating the signal modulated by said
modulation means, using said control voltage based on the
comparison result from said comparing means.

2. The radio telephone apparatus according to claim
1, wherein said transmitting means further comprises:

a counter for performing a counting operation based
on the comparison result outputted from said comparing
5 means and outputting a counted value; and

a D/A converter for converting the counted value
outputted from the counter to an analog signal, and

Fig. 1

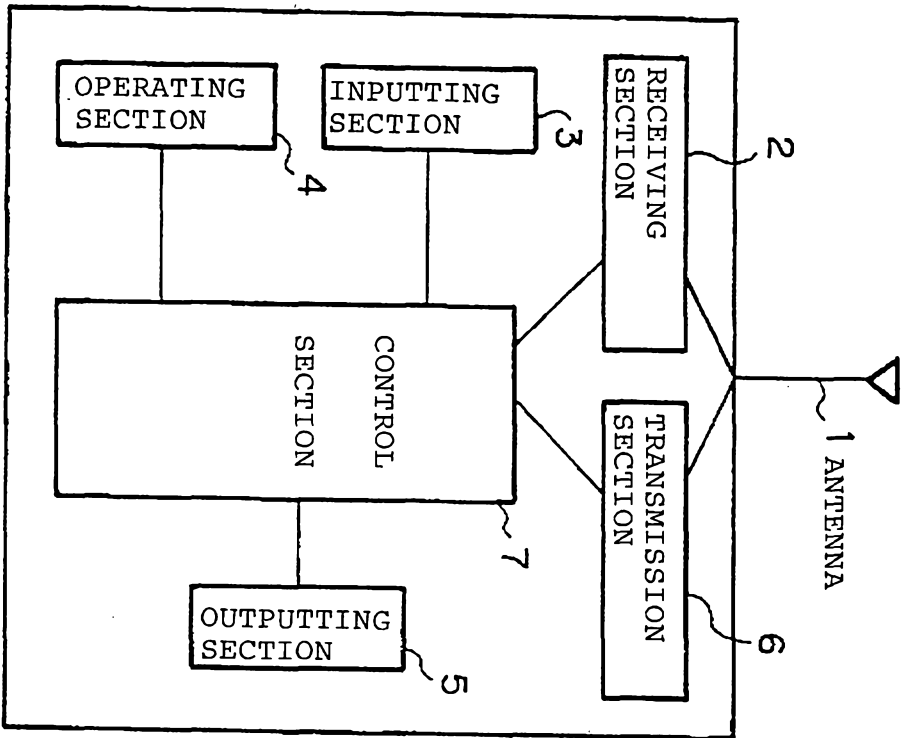

1 2 3 4 5 6 7

AUSTRALIA
PATENTS ACT 1990

COMPLETE SPECIFICATION

FOR A STANDARD PATENT

ORIGINAL

Name and Address
of Applicant: NEC Corporation
7-1, Shiba 5-chome
Minato-ku
Tokyo
JAPAN

Actual Inventor(s): Mitsuru Tanaka

Address for Service: Spruson & Ferguson, Patent Attorneys
Level 33 St Martins Tower, 31 Market Street
Sydney, New South Wales, 2000, Australia

Invention Title: Radio Telephone Apparatus

The following statement is a full description of this invention, including the best method of performing it known to me/us:-

RADIO TELEPHONE APPARATUS

BACKGROUND OF THE INVENTION

5 1. Field of the Invention

The present invention relates to a radio telephone apparatus which performs radio communications, more particularly to a power-saving control of a transmitted output in the radio telephone apparatus.

10 2. Description of the Related Art

A power-saving control of a transmitted output typified by a PHS radio telephone apparatus has been heretofore performed by limiting a dynamic range of a detection circuit provided therein. However, the method to
15 limit the dynamic range of the detection circuit has been able to lower the transmitted power by 15 to 20 dB at most.

Accordingly, when a power-saving control exceeding 20 dB is required, a method has been employed, in which a fixed bias voltage is applied to a voltage control
20 variable attenuator constituted by a pin diode and the like provided in a RF stage of a transmission system, and the power source of a driver amplifier is cut off, whereby a gain of the transmission system is lowered and the transmitted output is set to a predetermined power-saving
25 output.

However, in the foregoing power-saving control method

in the conventional radio telephone apparatus, during the power-saving control, an auto power control circuit (hereinafter, referred to as an APC circuit) in which a field back loop is formed is in an OFF state, so that
5 there is a problem that a variation in a gain of an amplifier in the transmission system owing to an ambient temperature change directly becomes a variation in the transmitted output, and a stable transmitted output can not be acquired.

10 Moreover, when a temperature compensation for the foregoing transmitted output is conducted, there is a problem that a circuit structure becomes complicated.

SUMMARY OF THE INVENTION

15 The present invention was made in consideration for the problems involved in the foregoing conventional arts, and the object of the present invention is to provide a radio telephone apparatus which is capable of obtaining a more stable transmitted output.

20 In order to achieve the above described object, a radio telephone apparatus of the present invention comprising:

an antenna for receiving and transmitting a radio wave;

25 receiving means for extracting a specified signal from the received radio wave through the antenna;

transmitting means for transmitting information to be transmitted to the outside through the foregoing antenna; and

control means for outputting a control signal for
5 lowering the transmitted output of the transmitting means by a specified amount, thereby controlling the transmitted output of the transmitting means,

wherein the foregoing transmitting means comprises:

modulation means for modulating the signal to be
10 transmitted through the foregoing antenna;

variable attenuating means for attenuating the signal modulated by the modulation means based on the control voltage inputted and outputting the attenuated signal;

amplifying means for directly outputting the signal
15 inputted from the variable attenuating means when the control signal is outputted from the control means, and amplifying the signal outputted from the variable attenuating means to output the amplified signal when no control signal is outputted from the control means;

20 detection means for demodulating the signal inputted from the amplifying means, and detecting a detection voltage by different circuits depending on whether or not the control signal is outputted from said control means, based on an output of the control signal from the control
25 means;

reference voltage generating means for generating

different reference voltages depending on whether or not the control signal is outputted from said control means, based on an output of the control signal from the control means; and

5 comparing means for comparing the reference voltage with the detection voltage detected by the detection means, thereby a comparison result, and

wherein the variable attenuating means attenuates the signal modulated by the modulation means, using the control voltage based on the comparison result from the comparing means.

The radio telephone apparatus of the present invention is characterized in that a counter is provided, which performs a counting operation based on the comparison result outputted from the comparing means and outputting a counted value, a D/A converter is provided, which converts the counted value outputted from the counter to an analog signal, and the variable attenuating means attenuates the signal modulated by the modulation means, using the analog signal outputted from the D/A converter as the control voltage.

The radio telephone apparatus of the present invention is characterized in that the detection means includes two resistors having different resistivities from each other, and switches the detection voltage to be inputted to the comparing means by selectively coupling

the comparing means with one of the two resistors based on the output of the control signal from the control means.

The radio telephone apparatus of the present invention is characterized in that the detection means has
5 two directional couplers exhibiting different degrees of coupling, and switches the detection voltage to be inputted to the comparing means by selectively coupling the comparing means with one of the two directional couplers, based on the output of the control signal from
10 the control means.

In the radio telephone apparatus of the present invention constructed as described above, the signal to be transmitted through the antenna is modulated by the modulation means provided in the control means, the signal
15 modulated by the modulation means is attenuated by the variable attenuating means based on the control voltage inputted thereto, the signal attenuated by the variable attenuating means is amplified for its power by the amplifying means and outputted therefrom, the signal
20 outputted from the amplifying means is demodulated by the detection means and the detection voltage is detected by the detection means, the detection voltage detected by the detection means is compared with a previously determined reference voltage by the comparing means, and the signal
25 modulated by the modulation means is attenuated by the variable attenuating means based on the comparison result

by the comparing means. Hereupon, the signal outputted from the variable attenuating means is directly outputted from the amplifying means when the control signal is outputted from the control means, and the signal outputted from the variable attenuating means is amplified for its power by the amplifying means and outputted therefrom when the control signal is not outputted from the control means. Furthermore, the detection means is constructed such that the detection voltage to be detected differs depending on the presence of outputting of the control signal from the control means.

As described above, the detection voltage is switched depending on the presence of outputting of the control signal from the control means and a feedback loop for controlling a transmitted power based on the comparison result of the detection voltage with the reference voltage is provided, so that a constant transmitted output can be achieved stably both at the times of a rated output and the power-saving control.

20

BRIEF DESCRIPTION OF THE DRAWINGS

For a more complete understanding of the present invention and the advantages thereof, reference is now made to the following description taken in conjunction with the accompanying drawings, in which;

Fig. 1 is a block diagram showing an embodiment of a

radio telephone apparatus of the present invention;

Fig. 2 is a block diagram showing a constitution example of a transmission section shown in Fig. 1;

Fig. 3 is a graph showing a relation between a
5 detection voltage and a resistor shown in Fig. 2; and

Fig. 4 is a block diagram showing another constitution example of the transmission section shown in Fig. 1.

10 DETAILED DESCRIPTION OF THE PREFERRED EMBODIMENTS

Embodiments of the present invention will be described with reference to the accompanying drawings below.

Fig. 1 is a block diagram showing an embodiment of a
15 radio telephone apparatus of the present invention, and Fig. 2 is a block diagram showing a constitution example of a transmission section shown in Fig. 1.

As shown in Fig. 1, the radio telephone apparatus of this embodiment comprises: antenna 1 for receiving and
20 transmitting a radio wave; receiving section 2 for extracting a predetermined signal from the radio wave received through antenna 1; inputting section 3 to which voice information from the outside is inputted; operating section 4 to which information other than a voice from the
25 outside is inputted; outputting section 5 for outputting the signal extracted by receiving section 2; transmission

section 6 for transmitting information to be transmitted to the outside through antenna 1; and control section 7 for outputting the information inputted through inputting section 3 and operating section 4 and outputting a power-saving control signal to lower a transmitted output by a predetermined amount to transmission section 6.

Moreover, as shown in Fig. 2, transmission section 6 in this embodiment comprises: modulator 10 for modulating a signal to be transmitted through antenna 1; voltage control variable attenuator 20 for attenuating the signal modulated by modulator 10 based on the control voltage to output the attenuated signal; power amplifier 40 for amplifying a power of the signal outputted from the voltage control variable attenuator 20 and outputting the amplified signal; driver amplifier 30 for generating a signal to drive power amplifier 40 from the signal outputted from voltage control variable attenuator 20; detection circuit 50 for demodulating the signal outputted from power amplifier 40 and detecting a detection voltage; reference voltage generating circuit 60 for generating a previously determined reference voltage and outputting the reference voltage; comparator 70 for comparing the detection voltage detected by detection circuit 50 with the reference voltage outputted from reference voltage generating circuit 60 and outputting a comparison result; up-down counter 80 for performing a counting operation

based on the comparison result outputted from comparator 70 and outputting a counted value; and D/A converter 90 for converting the counted value outputted from up-down counter 80 to an analog signal and outputting the analog
5 signal. The analog signal outputted from D/A converter 90 serves as a control signal for controlling an attenuation amount by modulator 10. It is to be noted that the signal outputted from power amplifier 40 is transmitted through antenna 1.

10 Furthermore, detection circuit 50 comprises:
microstrip line 51a connected between power amplifier 40 and antenna 1; microstrip line 51b for constituting a directional coupler in company with microstrip line 51a; terminal resistor 52 connected between one terminal of
15 microstrip line 51b and the ground terminal; detecting diode 53 having a cathode connected to a side of microstrip line 51b which is not grounded and an anode which is grounded; detection diode 54 having an anode connected to a side of microstrip line 51b which is not
20 grounded and a cathode connected to a first inputting terminal of comparator 70; capacitor 55 connected between the cathode of diode 54 and the ground; resistors 56a and 56b, each having one terminal grounded and serving to determine the detection voltage; and change-over switch 57
25 connected between the first inputting terminal of comparator 70 and sides of resistors 56a and 56b which are

not grounded, change-over switch 57 controlling a connection of resistors 56a and 56b and the first inputting terminal of comparator 70.

A transmission output control operation in the
5 transmission section constructed as described above will be described individually for the case where a rated output is transmitted and for the case wherein a power-saving output is transmitted.

First, the transmission output control operation for
10 the case where the rated output is transmitted will be described.

When a signal to be transmitted through antenna 1 is
outputted from control section 7, modulator 10 modulates
this signal so as to be transmitted through antenna 1 and
15 outputs the modulated signal.

Subsequently, voltage control variable attenuator 20
attenuates the signal outputted from modulator 10
according to a predetermined attenuation amount, and
outputs the attenuated signal. Hereupon, the attenuation
20 amount of voltage control variable attenuator 20 is determined based on the control voltage outputted from D/A converter 90.

Next, driver amplifier 30 generates a signal to drive
power amplifier 40 from the signal outputted from voltage
25 control variable attenuator 20. In power amplifier 40, the signal outputted from voltage control variable attenuator

20 is amplified to a rated transmission output by the signal generated signal by driver amplifier 30 and outputted. The supply of a driving power source of driver amplifier 30 is controlled based on the power-
5 saving control signal outputted from control section 7.

When the rated output is transmitted, in other words, in a state where the power-saving control signal is not outputted from control section 7, the driving power source is supplied.

10 Thereafter, the signal outputted from power amplifier 40 is transmitted through antenna 1, and is demodulated by detection circuit 50, so that the detection voltage is detected.

In the detection circuit 50, microstrip line 51b
15 which constitutes the directional coupler in company with microstrip line 51a detects the signal outputted from power amplifier 40, and the detected signal is converted to a DC current by diodes 53 and 54.

The signal converted to the DC current is inputted to
20 one terminal of change-over switch 57. Hereupon, the switching operation of change-over switch 57 is controlled based on the power-saving control signal outputted from control section 7. When the rated output is transmitted, in other words, in a state where the power-saving control
25 signal is not outputted from control section 7, the switching operation of change-over switch 57 is controlled

so that resistor 56b and the cathode of diode 54 are connected, whereby the signal converted to the DC voltage comes to flow across resistor 56b. It is to be noted that as to the resistivities of resistors 56a and 56b, the resistivity of resistor 56a is set to be larger than that of resistor 56b and the detection voltage emerges at the first inputting terminal of comparator 70.

Fig. 3 is a graph showing a relation between the detection voltage and resistors 56a and 56b shown in Fig. 2.

With reference to a characteristic of the detection voltage of detection circuit 50 against the load resistivity, as shown in Fig. 3, in general when the resistivity is large, the detection voltage becomes large, and when the resistivity is small, the resistivity becomes small.

Next, comparator 70 compares the detection voltage (V_{d1} in Fig. 3) emerging at the first inputting terminal of comparator 70 with the reference voltage (V_{r1} in Fig. 3) generated by reference voltage generating circuit 60, and outputs the comparison result. Hereupon, in reference voltage generating circuit 70, the reference voltage to be generated by reference voltage generating circuit 70 is controlled based on the power-saving control signal outputted from control section 7. When the rated output is transmitted, in other words, in a state where the power-

saving control signal is not outputted from control section 7, the reference voltage for the rated output is generated.

Subsequently, up-down counter 80 performs a counting operation based on the comparison result outputted from comparator 70, and outputs a counted value. Hereupon, when the detection voltage emerged at the first inputting terminal of comparator 70 is higher than the reference voltage generated by reference voltage generating circuit 60, the transmitted output is considered to be higher than the rated value, and the counted value of up-down counter 80 is decremented by one bit.

Thereupon, D/A converter 90 converts the counted value outputted from up-down counter 80 to the analog signal and the DC current amounting to one bit decreases, and the analog signal is applied to voltage control variable attenuator 20 as the control voltage.

Then, voltage control variable attenuator 20 attenuates the signal outputted from modulator 10 depending on the attenuation amount which is determined based on the control voltage outputted from D/A converter 90, and outputs the attenuated signal.

Hereupon, when the device of an APC circuit composed of comparator 70, up-down counter 80, D/A converter 90 and the like is constituted by a device of a 3V system, the detection voltage appearing at the first inputting

terminal of comparator 70 is generally designed and set to be 1 to 2 V near a center of the 3V system, by selecting degrees of coupling of microstrip lines 51a 51b, a resistivity of resister 56b and the like.

5 In this embodiment, the control operation in the foregoing APC circuit is repeated every transmission burst so that the detection voltage of the transmitted output becomes equal to the reference voltage generated by reference voltage generating circuit 60, whereby the
10 transmitted output that is the rated output is stably outputted.

Next, the transmission output control operation for a case when power-saving control is performed will be described.

15 When a signal to be transmitted through antenna 1 is outputted from control section 7, modulator 10 modulates this signal so as to be transmitted through antenna 1 and outputs the modulated signal.

Subsequently, voltage control variable attenuator 20
20 attenuates the signal outputted from modulator 10 according to a predetermined attenuation amount, and outputs the attenuated signal. Hereupon, the attenuation amount of voltage control variable attenuator 20 is determined based on the control voltage outputted from D/A
25 converter 90.

On the other hand, when power-saving control is

performed, since the power-control signal is outputted from control section 7, the power source is not supplied to driver amplifier 30, so that driver amplifier 30 and power amplifier 40 are not driven, and the signal
5 outputted from modulator 10 is directly outputted to detection circuit 50.

The signal outputted through power amplifier 40 is transmitted through antenna 1, and at the same time demodulated by detection circuit 50, followed by the
10 detection of the detection voltage.

In detection circuit 50, microstrip line 51b which constitutes the directional coupler in company with microstrip line 51a detects the signal outputted from power amplifier 40, and the detected signal is converted
15 to a DC current by diodes 53 and 54.

The signal converted to the DC current is inputted to one terminal of change-over switch 57. Hereupon, since the power-saving control signal is outputted from control section 7 to change-over switch 57, change-over switch 57
20 is controlled so that resistor 56b and the cathode of diode 54 are connected, whereby the signal converted to the DC voltage comes to flow across resistor 56a, and the detection voltage at the time of the power-saving control emerges at the first inputting terminal of comparator 70.

25 Next, comparator 70 compares the detection voltage (V_{d2} in Fig. 3) emerging at the first inputting terminal

of comparator 70 with the reference voltage (Vr2 in Fig. 3) generated by reference voltage generating circuit 60, and outputs the comparison result. Hereupon, when the power-saving control is performed, since the power-saving control signal is outputted from control section 7, the reference voltage generating circuit 60 generates the reference voltage for the power-saving control.

Next, up-down counter 80 performs a counting operation based on the comparison result outputted from comparator 70, and outputs the counted value.

Thereupon, D/A converter 90 converts the counted value outputted from up-down counter 80 to an analog signal, and the analog signal is applied to voltage control variable attenuator 20 as the control voltage.

Then, voltage control variable attenuator 20 attenuates the signal outputted from modulator 10 depending on the attenuation amount which is determined based on the control voltage outputted from D/A converter 90, and outputs the attenuated signal.

In this embodiment, the control operation in the foregoing APC circuit is repeated every transmission burst so that the detection voltage of the transmitted output becomes equal to the reference voltage generated by reference voltage generating circuit 60, whereby the constant transmitted output is stably outputted even when the power-saving control is being performed.

The dynamic range when power-saving control is performed can be enlarged up to about 20 to 40 dB.

(Another Embodiment)

Fig. 4 is a block diagram showing another
5 constitution example of the transmission section shown in Fig. 1.

As shown in Fig. 4, this embodiment differs from that shown in Fig. 2 only in the constitution of the detection circuit. and other constitutions are the same as those of
10 Fig. 2. This embodiment has a feature in that the directional coupler formed by the microstrip line is provided by two circuits in detection circuit 150.

In the transmission section shown in Fig. 4, when the rated output is transmitted, the detection circuit
15 composed of the directional coupler constituted by microstrip lines 51a and 51b is used, and comparator 70 compares the detection voltage emerging at the cathode of diode 54 with the reference voltage generated by reference voltage generating circuit 60.

20 On the other hand, when power-saving control is performed, the detection circuit composed of the directional coupler constituted by microstrip lines 51a and 61 is used, and comparator 70 compares the detection voltage emerging at the cathode of diode 64 with the
25 reference voltage generated by reference voltage generating circuit 60.

Hereupon, in this embodiment, the degree of coupling of the directional coupler constituted by microstrip lines 51a and 61 is set to be closer than that of the directional coupler constituted by microstrip lines 51a and 51b and the resistivity of load resistor 56a is set to be larger than that of resistor 56b, whereby the detection voltage emerging at the cathode of diode 64 becomes larger than that emerging at the cathode of diode 54.

As described above, in the radio telephone apparatus of the present invention, provided are modulation means for modulating a signal to be transmitted through an antenna; variable attenuating means for attenuating the signal modulated by the modulation means based on a control signal inputted thereto; amplifying means for amplifying the power of the signal attenuated by the variable attenuating means to output the amplified signal; detection means for demodulating the signal outputted from the amplifying means, thereby detecting a detection voltage; and comparing means for comparing the detection voltage detected by the detection means with a previously determined reference voltage, wherein the variable attenuating means takes a structure using a feedback loop which attenuates the signal modulated by the modulation means based on a comparison result from the comparing means, the amplifying means directly outputs the signal outputted from the variable attenuating means when a

control signal is outputted from the control means and amplifies the power of the signal outputted from the variable attenuating means to output the amplifies signal when the control signal is not outputted from the control
5 means, and the detection means switches the detection voltage depending on the presence of outputting of the control signal from the control means. Accordingly, the transmitted power is controlled so as to be different depending on the presence of the output of the control
10 signal from the control means, and a constant transmitted output can be obtained stably even when the rated outputting is performed and even when the power-saving control is performed, thus enlarging a dynamic range at the time of power-saving control.

~~What is claimed is:~~

The claims defining the invention are as follows.

1. A radio telephone apparatus comprising:
 - an antenna for receiving and transmitting a radio wave;
 - receiving means for extracting a specified signal
5 from the received radio wave through the antenna;
 - transmitting means for transmitting information to be transmitted to an outside through said antenna; and
 - control means for outputting a control signal to lower a transmitted output of said transmitting means by a
10 specified amount, thereby controlling the transmitted output of said transmitting means,
 - wherein said transmitting means comprises:
 - modulation means for modulating a signal to be transmitted through said antenna;
 - 15 variable attenuating means for attenuating the signal modulated by the modulation means based on a control voltage inputted and outputting the attenuated signal;
 - amplifying means for directly outputting the signal inputted from said variable attenuating means when said
20 control signal is outputted from said control means, and amplifying a power of the signal inputted from said variable attenuating means to output the amplified signal when said control signal is not outputted from said control means;

25 detection means for demodulating the signal inputted
from said amplifying means, and detecting a detection
voltage by different circuits depending on whether or not
the control signal is outputted from said control means,
based on an output of said control signal from said control
30 means;

reference voltage generating means for generating
different reference voltages depending on whether or not
the control signal is outputted from said control means,
based on an output of said control signal from said control
35 means; and

comparing means for comparing said reference voltage
with the detection voltage detected by said detection means,
thereby outputting a comparison result, and

wherein said variable attenuating means comprises
40 means for attenuating the signal modulated by said
modulation means, using said control voltage based on the
comparison result from said comparing means.

2. The radio telephone apparatus according to claim
1, wherein said transmitting means further comprises:

a counter for performing a counting operation based
on the comparison result outputted from said comparing
5 means and outputting a counted value; and

a D/A converter for converting the counted value
outputted from the counter to an analog signal, and

wherein said variable attenuating means comprises means for attenuating the signal modulated by said modulation means, using the analog signal outputted from the D/A converter as said control voltage.

3. The radio telephone apparatus according to claim 1, wherein said detection means comprises two resistors having resistivities different from each other, and means for selectively coupling one of the two resistors with said comparing means based on the output of said control signal from said control means, thereby switching the detection voltage to be inputted to said comparing means.

4. The radio telephone apparatus according to claim 2, wherein said detection means comprises two resistors having resistivities different from each other, and means for selectively coupling one of the two resistors with said comparing means based on the output of said control signal from said control means, thereby switching the detection voltage to be inputted to said comparing means.

5. The radio telephone apparatus according to claim 1, wherein said detection means comprises two directional couplers having degrees of coupling different from each other, and means for selectively coupling one of the directional couplers with said comparing means based on the

output of said control signal from said control means, thereby switching the detection voltage to be inputted to said comparing means.

5 6. The radio telephone apparatus according to claim 2, wherein said detection means comprises two directional couplers having degrees of coupling different from each other, and means for selectively coupling one of the directional couplers with said comparing means based on the output of said control signal from said control means, thereby switching the detection voltage to be inputted to said comparing means.

10 7. A radio telephone apparatus substantially as herein described with reference to Figs. 1 to 3; or Figs. 1 and 4 of the drawings.

DATED this First Day of April 1999

NEC Corporation

Patent Attorneys for the Applicant

SPRUSON & FERGUSON

15

Fig. 1

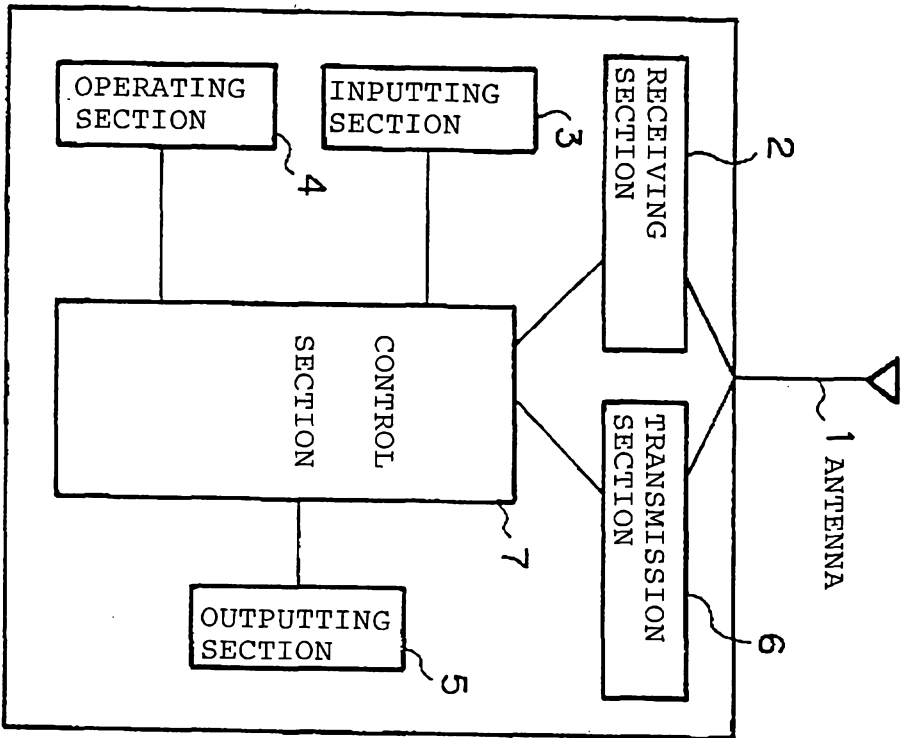

1 2 3 4 5 6 7

1 04 90 2349

Fig. 2

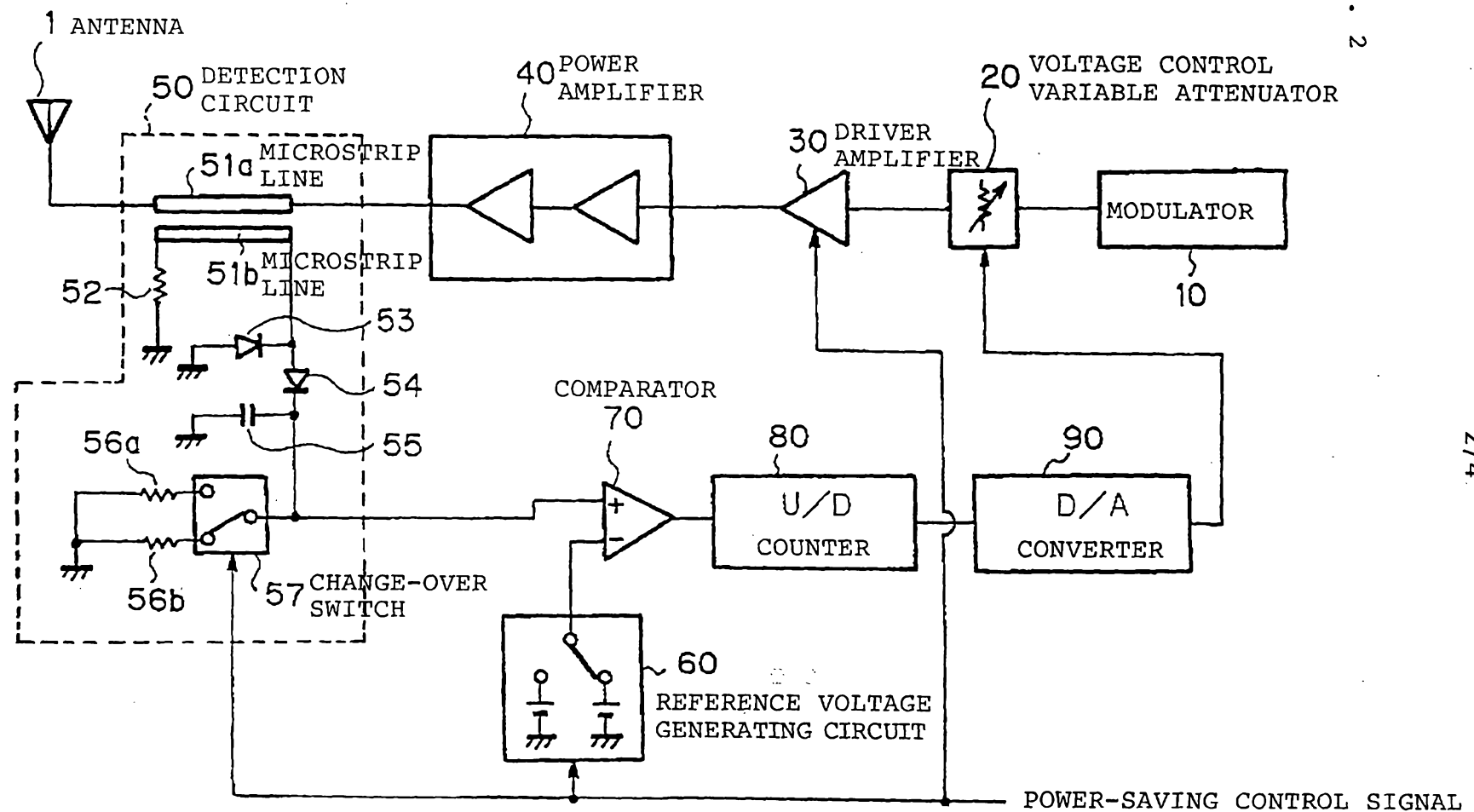

1 04 99 23549

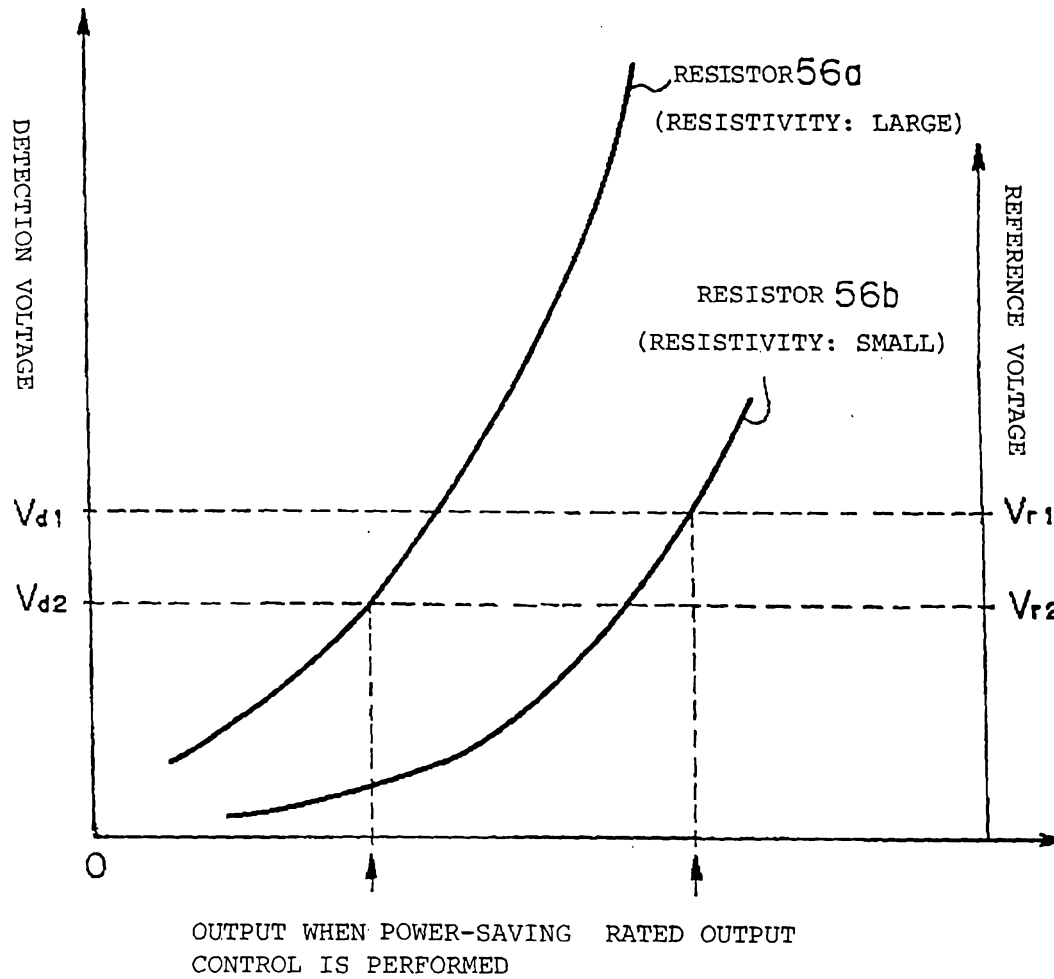

Fig. 3

Fig. 4

