



EUROPEAN PATENT APPLICATION

Application number : **94302813.4**

Int. Cl.⁵ : **B41J 2/16**

Date of filing : **20.04.94**

Priority : **29.04.93 US 55466**

Inventor : **Holstun, Clayton L.**
28411 Meadow Glen Way West
Escondido, California 92026 (US)
 Inventor : **Courian, Kenneth J.**
3536 Seahorn Circle
San Diego, California 92130 (US)

Date of publication of application :
02.11.94 Bulletin 94/44

Designated Contracting States :
DE FR GB IT

Representative : **Colgan, Stephen James et al**
CARPMAELS & RANSFORD
43 Bloomsbury Square
London WC1A 2RA (GB)

Applicant : **Hewlett-Packard Company**
3000 Hanover Street
Palo Alto, California 94304 (US)

Method for reducing spray in thermal ink jet pens firing polymer-containing inks.

Spray (or satellite drops) in thermal ink-jet pens firing inks containing polymer dispersants for pigments is reduced by increasing the distance between the firing resistor (10) and the nozzle (12). This may be done by offsetting the resistor with respect to the nozzle, increasing the thickness of the orifice plate (14), increasing the thickness of the barrier layer (18) which defines the firing chamber (20) and supports the nozzle plate, or recessing the resistor deeper into the substrate (16) on which it is supported. Any or all of the foregoing may be implemented to reduce spray. A combination of thicker top plates and offsetting the nozzle relative to the resistor is particularly efficacious in reducing spray.

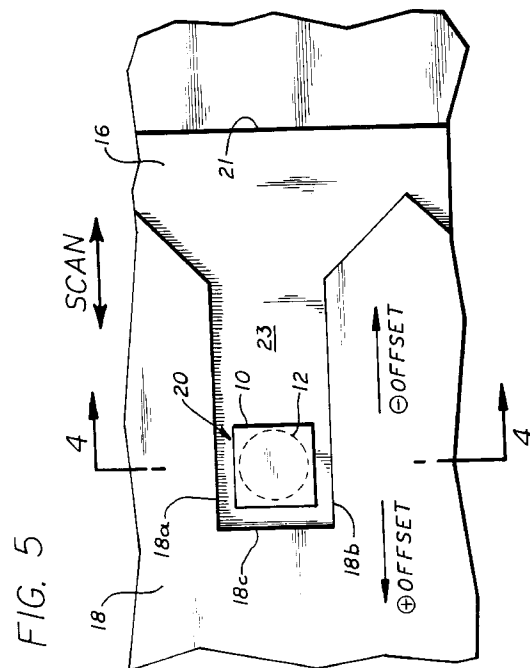

TECHNICAL FIELD

The present invention relates to thermal ink-jet pens employed in thermal ink-jet printers, and, more particularly, to improving the performance of such pens employing an ink which includes a polymer to aid in dispersion of a pigment colorant.

BACKGROUND ART

In the art of thermal ink-jet printing, it is known to provide a plurality of electrically resistive elements on a common substrate for the purpose of heating a corresponding plurality of ink volumes contained in adjacent ink reservoirs leading to the ink ejection and printing process. Using such an arrangement, the adjacent ink reservoirs are typically provided as cavities, or firing chambers, in a barrier layer attached to the substrate for properly isolating mechanical energy to predefined volumes of ink. The mechanical energy results from the conversion of electrical energy supplied to the resistive elements which creates a rapidly expanding vapor bubble in the ink above the resistive elements. Also, a plurality of ink ejection orifices are provided above these cavities in a nozzle plate and provide exit paths for ink during the printing process.

In the operation of thermal ink-jet printheads, it is necessary to provide a flow of ink to the thermal, or resistive, element causing ink drop ejection. This has been accomplished by manufacturing ink fill channels, or slots, in the substrate, ink barrier, or nozzle plate. U.S. Patent Nos. 4,438,191, 4,500,895, 4,528,577, and 4,578,687, all assigned to the same assignee as the present application, disclose examples of such thermal ink-jet printheads, which have been designed for water-based inks.

Water-based inks commonly employ one or more water-soluble dyes as the colorant. The colorant is a dye molecule that is dissolved in water. Such inks typically include the dye, water, at least one co-solvent (an organic water-miscible solvent, such as diethylene glycol), and minor amounts of other substances, such as biocides.

Recent ink formulations have been developed, which contain pigments as colorants instead of water-soluble dyes. It is imperative to maintain these pigments in a dispersed form, because the pigments are particles, and would otherwise tend to settle with time. The particles are held in dispersion by polymers called polymer dispersants. These polymer dispersants have functional groups; one functionality on the polymer is hydrophobic and associates with the pigment, while another functionality on the polymer is hydrophilic and associates with water. The polymer is of a length sufficient to keep the pigment particles separated. Examples of such pigment-polymer systems for ink-jet printers are disclosed, for example, in

U.S. Patent 5,085,698, issued to S.-H. Ma et al on February 4, 1992.

Inks which contain polymers tend to be more cohesive than inks not containing polymers. This property allows the tail of an ink drop to stay together and remain attached to the meniscus longer, and move to the paper essentially intact. This tends to reduce the amount of random spray which lands on the paper, and is a positive benefit. However, one of the consequences of this is that if the tail stays attached to the ink inside the cavity, a perturbation of the ink in the cavity due to the ink refilling or secondary bubble expansion, etc., can disturb the tail. In such an event, a small drop can separate from the back end of the tail. This satellite drop is large enough that it adversely affects the print quality.

Thus, there is a need to provide a method of preventing the formation of satellite drops during the firing of inks containing a polymer dispersant from a thermal ink-jet printhead.

DISCLOSURE OF INVENTION

In accordance with the invention, a method is provided for reducing spray (or satellite drops) in thermal ink-jet pens firing inks containing polymer dispersants. The method comprises increasing the distance between the firing resistor and the nozzle. More correctly, it is the distance between the firing resistor and the ink meniscus that is increased. However, since this is a dynamic state, it is convenient to discuss the increase in distance in terms of static elements, namely, the firing resistor and the nozzle. The increase in distance may be done by offsetting the resistor with respect to the nozzle, or increasing the thickness of the orifice plate, or increasing the thickness of the barrier layer which defines the firing chamber and supports the nozzle plate, or recessing the resistor deeper into the substrate on which it is supported. Any or all of the foregoing may be implemented to reduce spray.

Thicker top plates tend to eliminate these spurious drops completely, or reduce their size. In addition, offsetting the nozzle relative to the resistor in the pen scanning direction also suppresses the formation of the satellite drop. A combination of the two is particularly efficacious.

BRIEF DESCRIPTION OF THE DRAWINGS

FIG. 1 is an enlargement (15X) of a series of ink dots printed in a row, employing a pigment-polymer ink system printed from a prior art thermal ink-jet pen, depicting rows of dots with satellite dots;

FIG. 2 is an enlargement (40X) similar to that of FIG. 1, but showing a single vertical line, also depicting dots and associated satellite dots;

FIG. 3 is an enlargement (20X) of printed characters (a portion of the letters "p" and "e"), showing the results of printing characters, and evidencing spray or satellite dots around the characters; FIGS. 4A-F are cross-sectional views of a firing chamber in a thermal ink-jet pen, depicting the time sequence of events of ink being fired, the ink containing a pigment-polymer system, and showing development of a tail portion that produces spray or satellites dots on the print medium; FIG. 5 is a top plan view of the firing chamber depicted in FIGS. 4A-F, with the nozzle above the resistor shown in phantom; FIGS. 6A-G, at an enlargement of 10X, depict the effect on satellite dot formation as a function of the extent of offsetting the nozzle relative to the resistor; FIGS. 7A-D, at an enlargement of 10X, depict the effect on satellite dot formation as a function of the thickness of the nozzle plate, with the nozzles at zero offset; and FIGS. 8A-D, at an enlargement of 10X, depict the effect on satellite dot formation as a function of the thickness of the nozzle plate, with the nozzles at -4 μm offset.

BEST MODES FOR CARRYING OUT THE INVENTION

FIG. 1 depicts a series of horizontal lines fired by a single nozzle in a thermal ink-jet pen having an ink which includes a pigment-polymer system. As can be seen, the horizontal lines show a pattern of regular "satellite" dots extending beyond the end of the line. These satellite dots are spaced about the same distance apart as the main drops. They can happen on either the odd or the even nozzles, but not generally from both odd and even on a single pen, and often just from some nozzles. As used herein, the term "odd nozzles" refers to one column of nozzles in a dual-column pen. The term "even nozzles" refers to the other column.

FIG. 2 depicts a plot consisting of vertical lines extending the length of the page. The plot was generated by just the odd nozzles firing. FIG. 2 shows that a single firing would produce a main drop and a satellite drop. From this, it may be inferred that these satellites are formed even when a drop is fired with the meniscus stationary at its equilibrium position. Thus, all frequency-dependent refill considerations may be ignored. This means that aspects of the internal pen architecture relating to barrier inlet shape and shelf length are not significant contributors to the problem.

FIG. 3 shows an enlargement of a printed sample. Due to the spray, the print quality is deemed unacceptable. The present invention is directed to reducing that spray.

FIGS. 4A-F depict in time sequence what is believed to be happening to generate the satellite dots when using an ink containing a pigment-polymer system. The Figures depict a side elevational view of one firing resistor **10** and associated nozzle **12** in a nozzle plate **14**. The resistor **10** is supported on a substrate **16**. A barrier layer **18** defines the firing chamber **20** in which the resistor **10** resides, and is seen to the left and right of the resistor, forming two walls, **18a** and **18b**. A further barrier wall (**18c**, shown in FIG. 5) is "above" the plane of the Figure; the three barrier walls **18a**, **18b**, **18c** define three sides of the firing chamber **20**, leaving a fourth wall open. Ink **22** enters the firing chamber **20** from an ink feed slot (not shown in FIGS. 4A-F, denoted **21** in FIG. 5), which is in slot form and supplies ink to a plurality of resistors on either side (one side is the "even" side, and the other side is the "odd" side) from a reservoir (not shown) beneath the substrate **16**. The ink feed slot fluidically communicates with the firing chamber **20** by means of a barrier inlet channel **23**. The barrier inlet channel **23** connects with the firing chamber **20** through the open wall and thus is "below" the plane of the Figure. FIG. 5 is a top plan view of firing resistor **10** in the firing chamber **20**, together with the barrier walls **18a**, **18b**, **18c** and the ink feed slot **21**.

FIG. 4A depicts ink in the equilibrium state. As the drop is ejected (FIG. 4B), the meniscus of the ink **22** retracts into the firing chamber **20** to make up for the ink that is forming the head **22a** and tail **22b** (FIGS. 4C, 4D). With the pigment-polymer ink system, the tail stays attached to the meniscus as it does this. At this point, the firing bubble **24** is collapsing. As the volume of the bubble **24** gets very small, computer simulations and physical observations suggest that its pressure increases and it re-expands slightly (FIG. 4E). This secondary expansion can cause a secondary jet 10 to 20 μsec after the first jet. This secondary jet can impact on the underside of the nozzle plate **14**; emerge, and hit the tail of the main drop, causing it to break up early; or make it all the way to the print medium (not shown) itself. But, in the present case, all the re-expansion has to do is disturb the symmetric nature of the meniscus (FIG. 4E). Since the tail is still attached to the meniscus, it gets "pushed" off-axis as shown by portion **22c**. The surface tension forces in the tail are then imbalanced, and the tail begins to roll up from the break-off point until a large enough volume separates and forms the satellite (FIG. 4F) from portion **22c**.

Dye-based inks exhibit this problem as well, but not to the same degree. These inks tend to separate from the meniscus earlier, and so are less susceptible to bubble rebound. Their tails are also thinner, so there is less ink around to feed a satellite when the tail is pushed off-axis. Thus, the problem seen with pigment-polymer ink systems was not observed with aqueous dye-based ink systems.

In accordance with the invention, the dimension between the top of the nozzle plate **14** and the resistor **10** is increased from about 50 μm to 60 μm , or by about 10 μm . This can be done by (1) offsetting the nozzle **12** with respect to the resistor **10**, (2) making the nozzle plate thicker, (3) making the barrier layer **18** thicker, or (4) etching out a "pit" in the floor of the firing chamber **20** in which the resistor is placed. Any combination of these approaches may also be employed.

More correctly, it is the distance from the retracted meniscus **22** to the firing resistor **10** that is increased. More specifically, the retracted meniscus location is raised relative to the resistor surface in order to keep it away from the re-expanding ink bubble. Thicker orifice plates, thicker barrier layer, or recessing the resistor would accomplish the goal of increasing this distance. Nozzle offset can help move the meniscus location away from the location of a re-expanding bubble. Also, increasing the firing chamber volume itself can reduce the amount of meniscus retraction, thereby effecting the same goal.

In the default condition, there is zero offset between the center of the resistor **10** and the center of the orifice **12**. FIG. 5 depicts the default condition, as well as the direction of offset between the center of the resistor **10** and the orifice **12** (shown in phantom). Negative offset is in the scanning direction of the pen, produced by moving the nozzle towards the ink feed slot **21**.

FIGS. 6A-G depict firing all resistors with the pen in a stationary position. FIG. 6A is with +4 μm offset, by which is meant that the nozzles **12** were moved 4 μm closer to the third wall **18a** of the firing chamber **20**. FIG. 6B is with zero offset, which is what is presently commercially employed in thermal ink-jet pens, and FIGS. 6C-G are with -4, -8, -12, -16, and -20 μm offset, respectively, by which is meant that the nozzles were offset in the direction of the ink feed slot **21**. It is clear that satellites are reduced where the offset ranges from between 0 offset and -12 μm (in the direction of the ink feed slot). Preferably, the offset ranges from about -4 to -8 μm .

In another approach, the distance from the resistor **10** to the top of the nozzle plate **14** can be increased by simply increasing the thickness of the nozzle plate. This has the effect of making the meniscus and the rebound bubble interact less by, in essence, putting more ink in between them. FIGS. 7A-D each depict a plurality of vertical lines, printed from pens in which the nozzle plate **14** was 48 μm thick (FIG. 7A), 53 μm thick (FIG. 7B), 57 μm thick (FIG. 7C), and 61 μm thick (FIG. 7D).

In these studies, the nozzle offset was zero. The suppression of satellites only occurs from about 57 to 61 μm .

While either nozzle offset or thicker nozzle plates alone can significantly reduce satellite dots, a com-

ination of the two gives the best performance, as shown in FIGS. 8A-D. The same nozzle plate thicknesses were employed as in FIGS. 7A-D; in this case, the nozzle offset was -4 μm . Here the satellites are smaller even with the thinnest nozzle plate, and are suppressed at 53 μm thickness and above.

With regard to increasing the thickness of the barriers, thicker barriers have been found to demonstrate the same effect as thicker top plates. However, thicker barriers present a drawback, namely, they increase the height of the refill inlet **23**. This causes the ink to refill too fast. Present manufacturing techniques do not allow a decrease in the width of the refill inlet **23** sufficiently to compensate for this increased height.

The offset employed in the present invention is different than the offset disclosed and claimed in U.S. Patent 4,794,411, issued December 27, 1988, and assigned to the same assignee as the present application. The offset in that patent ranges from 1 to 25 μm , and is to correct trajectory of the first drop of ink (in the single drop mode) or of the second and subsequent drops (in the multi-drop mode), particularly when the pen is operating at high frequencies (on the order of 50 kHz) and with up to 10 drops per firing burst. While that patent does not disclose the nature of the ink employed, all studies were performed with conventional aqueous dye-based ink systems.

INDUSTRIAL APPLICABILITY

The use of an increased distance between the resistor and the top of the nozzle plate is expected to find use in thermal ink-jet pens that employ an ink which includes a pigment-polymer system.

Thus, there has been disclosed reduction of spray in thermal ink-jet pens firing polymer-containing inks. It will be readily apparent to those skilled in this art that various changes and modifications of an obvious nature may be made, and all such changes and modifications are considered to fall within the scope of the invention, as defined by the appended claims.

Claims

1. A method for fabricating thermal ink-jet pens suitable for firing polymer-containing inks with reduced spray, said pens including
 - (a) a substrate (**16**);
 - (b) a plurality of resistive heating elements (**10**) supported on said substrate (**16**);
 - (c) a barrier layer (**18**) surrounding each said resistive heating element (**10**) and defining a firing chamber (**20**) for each said resistive heating element (**10**), at least partially open on one side, said barrier layer (**18**) having a

- nominal thickness of about 25 μm ;
- (d) each said open space in said barrier layer (18) defining a barrier inlet channel (23) which fluidically communicates with said firing chamber (20);
- (e) an ink feed slot (21) through said substrate (16) and common to each said barrier inlet channel (23) and fluidically communicating therewith and with an ink reservoir beneath said substrate (16);
- (f) a nozzle plate (14) supported on said barrier layer (18) and provided with a plurality of nozzles (12), each nozzle (12) associated with each said resistive heating element (10) such that the center of each said nozzle (12) aligns with the center of each said resistive heating element (10) to provide a zero offset therefrom, said nozzle plate (14) having a nominal thickness of 48 μm , wherein the method comprises increasing the distance from said resistive heating elements (10) to the top of said nozzle plate (14).
2. The method of Claim 1 wherein said center of each said nozzle (12) is offset from said center of each said resistive heating element (10) by an amount ranging from about 4 to 8 μm in the direction of said opening (23).
3. The method of Claim 2 wherein said nozzle plate (14) is increased to a thickness of at least about 53 μm ,
4. The method of Claim 3 wherein said center of each said nozzle (12) is offset from said center of each said resistive heating element (10) by an amount of about 4 μm in the direction of said opening (23) and wherein said nozzle plate (14) is increased to a thickness of about 61 μm .
5. The method of Claim 1 wherein said nozzle plate (14) is increased to a thickness of at least about 57 μm .
6. The method of Claim 1 wherein said barrier layer (18) is increased to a thickness of at least about 38 μm .
7. The thermal ink-jet pen of Claim 1, including:
- (a) said substrate (16);
- (b) said plurality of resistive heating elements (10) supported on said substrate (16);
- (c) said barrier layer (18) surrounding each said resistive heating element (10) and defining said firing chamber (20) for each said resistive heating element (10), at least partially open on one side, said barrier layer (18) having a nominal thickness of about 25 μm ;
- (d) each said open space in said barrier layer (18) defining said barrier inlet channel (23) which fluidically communicates with said firing chamber (20);
- (e) said ink feed slot (21) through said substrate (16) and common to each said barrier inlet channel (23) and fluidically communicating therewith and with said ink reservoir beneath said substrate (16);
- (f) said nozzle plate (14) supported on said barrier layer (18) and provided with said plurality of nozzles (12), each nozzle (12) associated with each said resistive heating element (10) such that the center of each said nozzle (12) aligns with the center of each said resistive heating element (10) to define said zero offset therefrom, said nozzle plate (14) having a nominal thickness of less than about 50 μm , whereby at least one of the following conditions obtains:
- (1) said center of each said nozzle (12) is offset from said center of each said resistive heating element (10) by an amount ranging from about 4 to 8 μm in the direction of said opening (23);
- (2) said nozzle plate (14) has a thickness of at least about 53 μm ; and
- (3) said barrier layer (18) has a thickness of at least about 38 μm .
8. The thermal ink-jet pen of Claim 7 wherein said center of each said nozzle (12) is offset from said center of each said resistive heating element (10) by an amount of about 4 μm in the direction of said opening (23) and wherein said nozzle plate (14) is increased to a thickness of about 61 μm .
9. The thermal ink-jet pen of Claim 7 wherein said nozzle plate (14) has a thickness of at least about 57 μm .

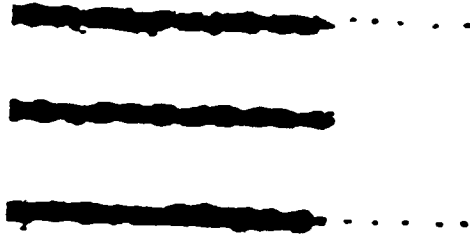

FIG. 1
PRIOR ART

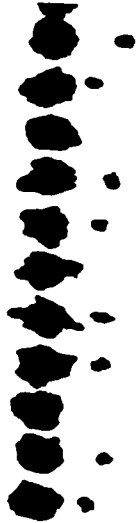

FIG. 2
PRIOR ART



FIG. 3
PRIOR ART

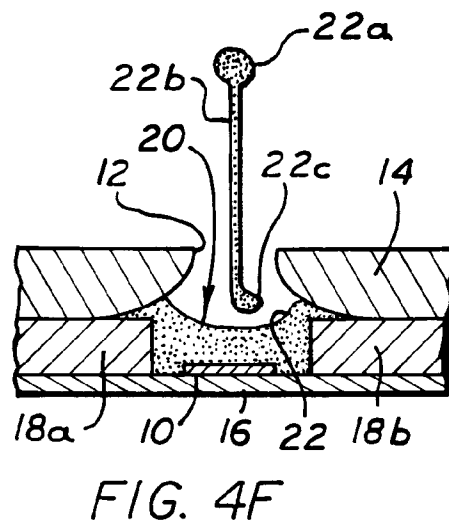
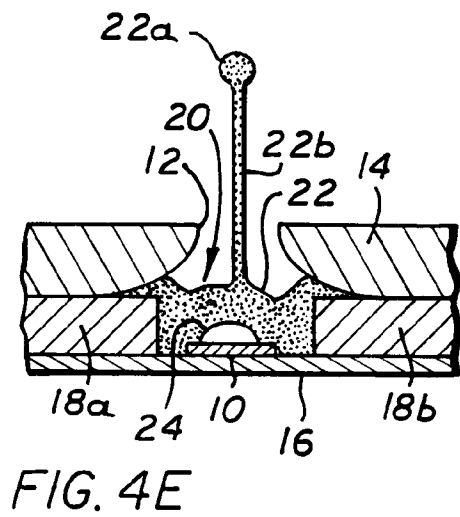
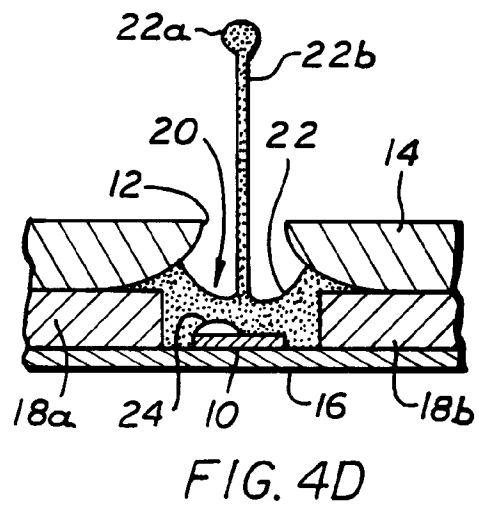
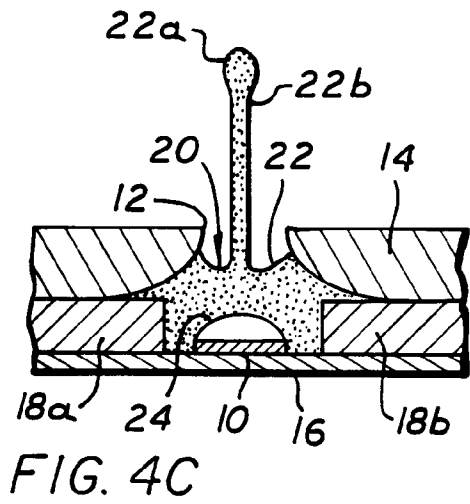
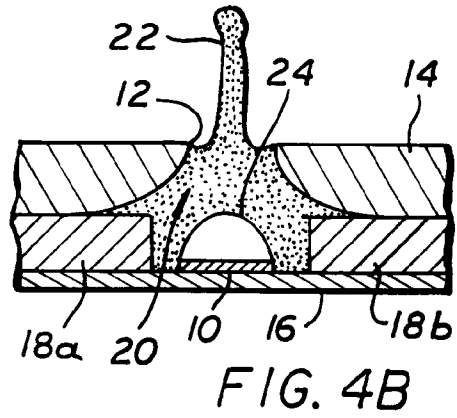
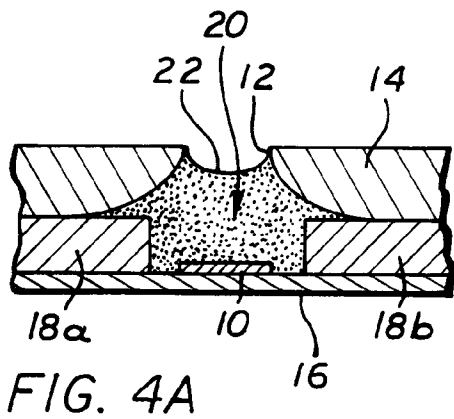

FIG. 5

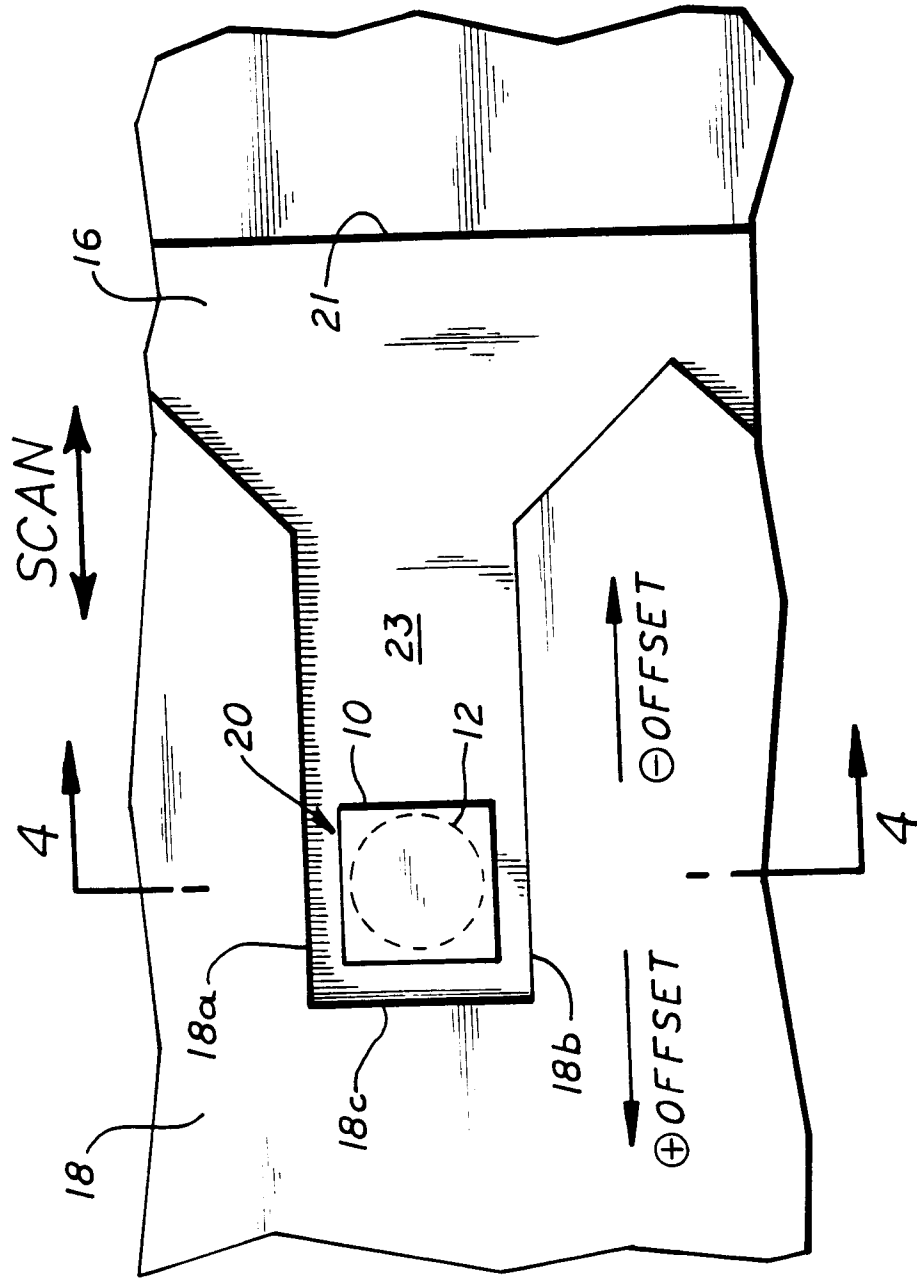
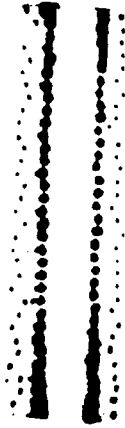

FIG. 6A



+4 OFFSET

FIG. 6B



0 OFFSET

FIG. 6C



-4 OFFSET

FIG. 6D



-8 OFFSET

FIG. 6E

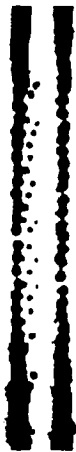

-12 OFFSET

FIG. 6F

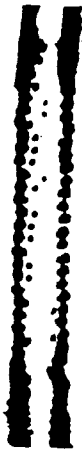

-16 OFFSET

FIG. 6G



-20 OFFSET



FIG. 7A

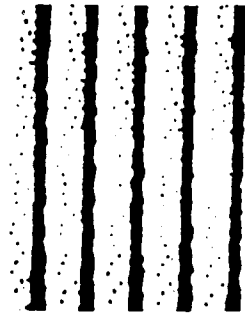

FIG. 7B



FIG. 7C



FIG. 7D

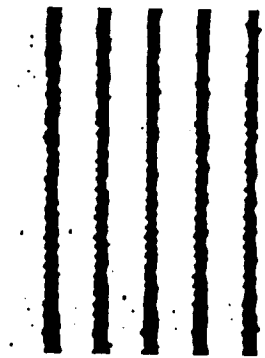

FIG. 8A

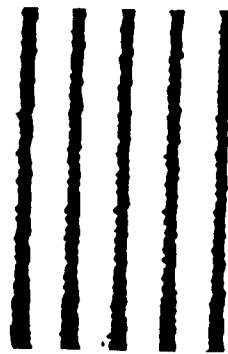

FIG. 8B



FIG. 8C



FIG. 8D