

J. N. LAPOINTE.  
KEY SEAT CUTTER.

(Application filed Nov. 17, 1900.)

(No Model.)

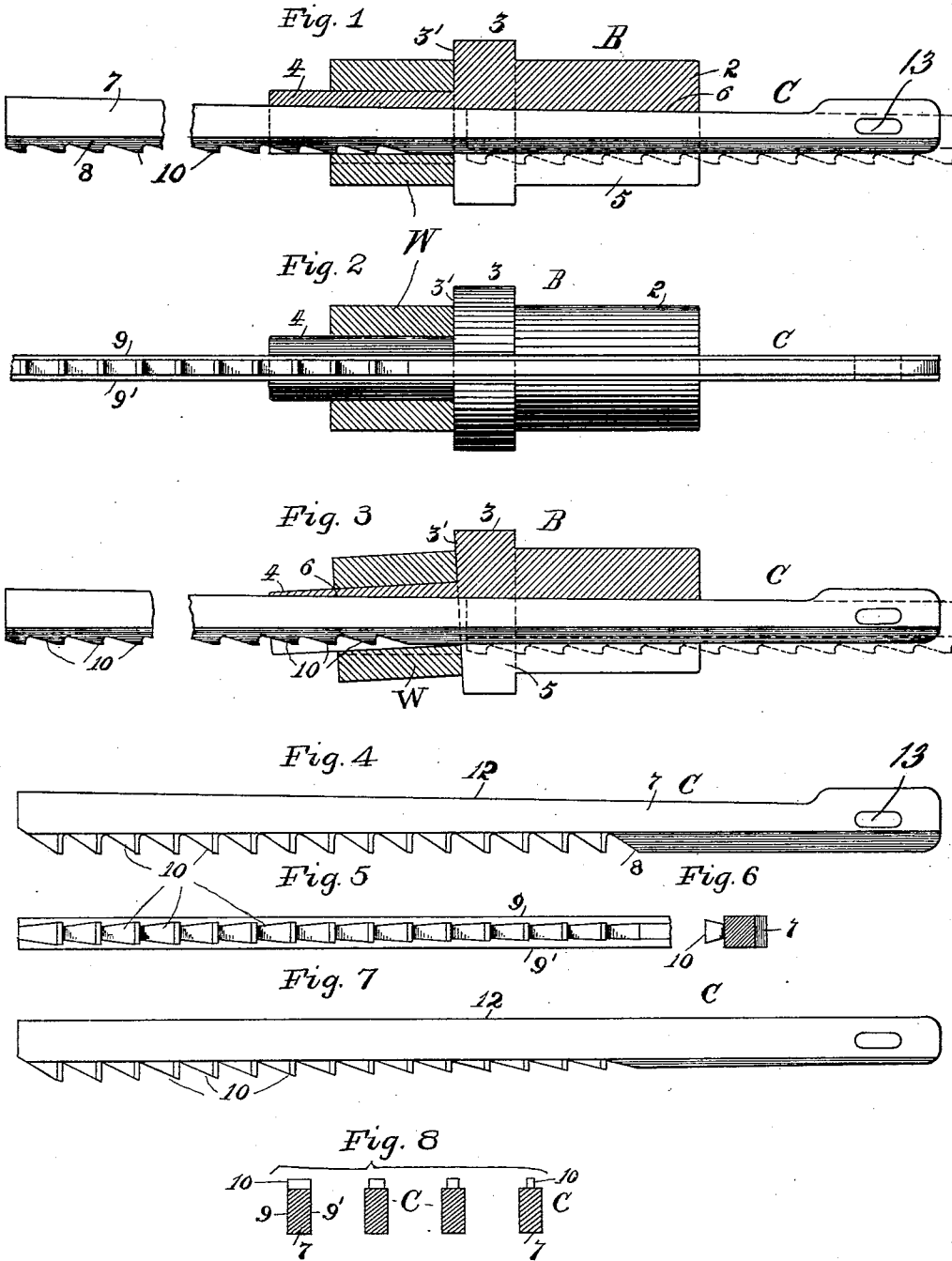

Witnesses  
Wm. P. Laraway  
L. C. Wood.

Inventor  
Joseph N. Lapointe  
by Whitney DeWitt

# UNITED STATES PATENT OFFICE.

JOSEPH N. LAPOINTE, OF HARTFORD, CONNECTICUT.

## KEY-SEAT CUTTER.

SPECIFICATION forming part of Letters Patent No. 685,772, dated November 5, 1901.

Application filed November 17, 1900. Serial No. 36,898. (No model.)

*To all whom it may concern:*

Be it known that I, JOSEPH N. LAPOINTE, a citizen of the United States of America, and a resident of the city and county of Hartford, in the State of Connecticut, have invented certain new and useful Improvements in Key-Seat Cutters, of which the following is a specification.

This invention relates to a device especially adapted for cutting grooves, key-seats, or splines in the inner faces of hubs, collars, sleeves, &c., and will for convenience be hereinafter termed a "key-seat cutter," the present key-seat cutter being distinguished from a "key-seat-cutting machine" in that it simply embodies a cutting-blade and a blade-guiding work-holder and may be applied as an attachment to various kinds of metal-working machines embodying means adapted for holding the guide and for reciprocating the cutting-blade.

An object of the present invention is to provide an improved, simplified, efficient, and rapidly-operating key-seat cutter in which the toothed cutting-blade is tapered widthwise in the direction of its length and is directly guided in its reciprocatory movements in a plane-faced longitudinal groove in a work-holder, and whereby on account of interchangeability straight, tapered, or dovetail grooves of various widths and depths may be readily formed in the interior of pieces of work, each groove being completed at each stroke of the cutting-blade.

A further object of the invention is to provide an improved key-seat cutter embodying a work-holder adapted to be attached to the head of the machine and having a substantially radial groove formed in the periphery and extending from end to end thereof and a unitary toothed cutting-blade having parallel side faces and relatively oblique edges and disposed for reciprocatory movements in the groove in said work-holder and adapted to be engaged and operated by a reciprocatory member of the machine, to which the work-holder is attached.

With these objects in view the invention consists in certain details of construction and in the combination and arrangement of the parts of the key-seat cutter, substantially as

hereinafter described, and more particularly pointed out in the claim.

In the drawings accompanying and forming part of this specification, Figure 1 is a central longitudinal section, partly in elevation, of a key-seat cutter embodying the present invention in one form thereof, a piece of work being shown supported in position to be operated upon by the cutter-blade and the cutter-blade being shown in full lines in its advanced position and in dotted lines in its retracted position. Fig. 2 is an under side view of the parts illustrated in Fig. 1 with the piece of work in section. Fig. 3 is a view similar to Fig. 1 of the key-seat cutter, showing the combined work-holder and cutting-blade guide constructed to support a piece of work at an angle and in position to facilitate the formation of an inclined key-seat therein. Figs. 4, 5, and 6 are side, edge, and sectional views, respectively, of a cutting-blade embodying this invention and adapted for forming a dovetail groove or key-seat in a piece of work, the working faces of the successive teeth of this blade being of corresponding depths in the direction of the width of the blade, and each tooth has relieved side faces. Fig. 7 is a side view of a dovetail-key-seat cutting blade in which the cutting-faces of the successive teeth are of successively-increased depths, and Fig. 8 illustrates in cross-section four cutting-blades the body portions of which are of corresponding widths and the toothed cutting edges of which are of relatively different widths.

In the preferred construction and organization thereof illustrated in the accompanying drawings the key-seat cutter comprises two members which are designated, respectively, by B and C, the one B of which is constructed in one piece and constitutes a work-support and cutting-blade guide, and the one C of which is also of unitary structure and constitutes a cutting-blade and is disposed for reciprocatory movements in the guide B.

In the form shown in the drawings the cutting-blade guide comprises a cylindrical body portion or barrel 2, having at the outer end thereof a circumferential flange 3, and a diametrically-reduced cylindrical work-supporting portion 4, formed integral with the outer

face of said flange, and which member B has a guiding groove or slot 5 formed in one face thereof and extending from end to end, preferably in parallelism with the longitudinal axis of said member, said slot being of a width substantially equal to the width of the body or non-toothed portion of the cutting-blade C and having parallel side faces cooperative with the plane side faces of said blade and also having a plane inner bearing and guiding face 6 cooperative with the plane edge of said blade. The work-supporting portion 4 of the member B may have its supporting-face in parallelism with the plane guiding-face 6 of said member, as shown in Figs. 1 and 2, whereby to support the work W in position to have a groove or key-seat of uniform depth from end to end formed in the inner wall thereof, or the supporting portion 4 may be set with its periphery at an angle to the inner bearing-face 6, so that the work W may be supported in position to have a tapered groove cut in the inner wall thereof, as shown in Fig. 3. In either case the outer end or abutment-face 3' of the circumferential flange 3, against which the work bears when in position to be operated upon, will be disposed at right angles to the longitudinal axis of the work-supporting portion 4.

In the preferred construction thereof illustrated in the accompanying drawings the member C is shown as an elongated cutting-blade comprising a body portion 7 and a cutting portion 8, the former of which has parallel side faces 9 and 9' and the latter of which has formed therein a plurality of teeth 10. The blade is so constructed that the extreme cutting-points of successive teeth, which define one extreme edge of the blade, are disposed at successively different distances from diametrically opposite portions of the other edge 12 of said blade. In other words, the edge 12 of the blade will have a plane straight face disposed in oblique relation to the opposite edge of the blade defined by the extreme cutting-points of the teeth 10. The cutting-blade may be constructed in several ways to accomplish this end. For instance, the teeth 10 may have their extreme cutting-points disposed in a line parallel to the longitudinal axis of the cutting-blade and have their cutting-faces of corresponding depths, and the opposite plane edge 12 of the blade may be disposed oblique to the longitudinal axis of the cutting-blade, or the teeth may have their extreme cutting-points disposed to define a line oblique to the longitudinal axis of the cutting-blade, and the opposite edge of said blade may be disposed in parallelism to said axis. It is distinctly to be understood that this invention is not limited to the particular construction of cutting-blade illustrated in the accompanying drawings, as this is subject to some modification within the purview of this invention.

In Fig. 1 of the drawings the cutting-blade is shown having successive teeth of equal

depth, whereas in Fig. 7 the cutting-blade is shown having successive teeth of successively-increased depths from the inner toward the outer end of said blade.

In the drawings I have shown two different kinds of blades, one adapted for cutting grooves having parallel side faces and the other adapted for cutting grooves having dovetailed side faces, and both of which blades embody the present invention.

The blades illustrated in Figs. 1, 2, and 3 have the cutting-faces of the teeth of corresponding widths in the direction of the thickness of the blade, the side edges of said teeth defining parallel lines, whereas the blades illustrated in Figs. 4 to 7, inclusive, have the cutting-faces of the successive teeth of successively-increased widths in the direction of the thickness of the blade, the side edges thereof defining relatively oblique lines, and the side faces of said teeth are dovetailed or converge toward their roots. (See Fig. 6.) In this latter case the side faces, as well as the cutting edges of the teeth, will be relieved for obvious reasons.

The work-supporting portion 4 of the member B will be of such diameter with relation to the width of the blade C and to the depth of the groove 5, formed in said member, that when the blade is in its advanced position (shown in full lines in Fig. 1) the cutting edges of those teeth located in the work-supporting member will not project beyond the outer face thereof, so that the work W may be readily slipped over the larger outer end of the blade into position upon the supporting portion 4 of the member B, as will be readily understood by reference to Figs. 1 and 3 of the drawings, it of course being apparent that the width of the blade at its larger end will be less than the internal diameter of the piece of work.

To facilitate the cutting of grooves of different widths, the work-support and cutting-blade guide B will have the guiding-groove 5 of sufficient width to accommodate the thickest blade it is desired to use in connection therewith, and a series of blades having body portions of corresponding thicknesses, but having cutting edges or teeth of relatively different thicknesses, will be provided for use in connection with each work-holder and blade-guide, a series of such blades being shown in Fig. 8.

In practice the key-seat cutter will be used in connection with a machine (not shown) having a recessed head adapted to receive the larger cylindrical end or barrel 2 of the member B (said barrel having a smooth periphery) and having a reciprocatory blade-actuator or member, including means for engaging in the slot 13, formed transversely through the inner end of the cutting-blade C. Inasmuch as the supporting means for the member B and the actuating means for the cutting-blade C may be of any desired or suitable construction, it is deemed unnecessary to illustrate these elements. The slot 13 in the inner end of the

blade C constitutes a convenient means whereby said blade may be directly attached to a blade-actuator; but it will be obvious that this feature is subject to some modification.

5 It will be understood that the work-support and cutting-blade guide is subject to some modification without departure from this invention.

10 In operation after the work is supported upon the work-supporting portion 4 of the member B the blade will be retracted from the advanced position shown in full lines in Fig. 1 to the position shown in dotted lines in said figure, thus cutting a groove of the 15 requisite depth in the work W at one retractive stroke of the blade, the successive teeth taking successively deeper cuts in the material, as will be readily understood.

20 I am aware that an internal-key-seat cutter has been heretofore devised in which a cutter-blade of uniform width has been secured by a fastening device in a groove of gradually-tapered depth formed in a cutter-carrier, said carrier being of a shape and size to fit 25 the hole or opening in the hub in which it is desired to form the key-seat. I am also aware that an external-key-seat cutter has been heretofore devised in which a cutter-blade has been secured by screws to one side of a 30 cutter-slide supported for reciprocatory movements and in which the cutter-blade was slightly inclined to the line of movement of the slide; but these constructions I do not desire to claim.

35 To form a key-seat in the inner face of a hub having a bore of very small diameter, it has been found impracticable to employ a cutting implement comprising a cutting-blade and a cutting-blade carrier, both of which 40 must necessarily be passed through the bore in which the key-seat is to be formed. Furthermore, with key-seat cutters in which the

cutting-blade is mounted upon or secured to a carrier which fits the bore or in which the carrier and blade together are reciprocated 45 in a bushing fitting said bore considerable difficulty has been experienced on account of the tendency of the several parts to rotate or become misaligned, due to the cutting-blade working loose in its carrier either transversely 50 or in the plane of its width, and it was to overcome these objections that I have after many and diversified practical experiments devised the herein-described two-piece key-seat cutter, comprising a work-holding cutting-blade 55 guide of unitary structure having a narrow longitudinal guiding-groove, the faces of which are parallel in the direction of their lengths and are rectangularly disposed cross-sectionally, and a thin one-piece cutting-blade 60 having three plane faces directly engaging the plane faces of the guiding-groove, whereby said blade will be positively held as against rotative and sidewise movements.

I claim—

65 The herein-described key-seat cutter, comprising an integral cutting-blade guide consisting of a barrel having a smooth periphery and a collar, and projecting from said collar, a work-support of less diameter than the bar- 70 rel, the barrel, collar and work-support being provided with a longitudinal slot extending through the axial line of said parts and open on one side, in combination with a toothed cutting-blade of substantially the 75 same width as the slot and having plane sides and an end adapted to be engaged by the reciprocatory member of a machine.

Signed by me at Hartford, Connecticut, this 8th day of November, A. D. 1900.

JOSEPH N. LAPOINTE.

Witnesses:

E. C. WHITNEY,  
L. C. WOOD.