



US00D390220S

**United States Patent** [19]  
**Matsuoka**

[11] **Patent Number:** **Des. 390,220**  
[45] **Date of Patent:** **\*\*Feb. 3, 1998**

[54] **DISC RECORDER**

[75] **Inventor:** **Yoshimichi Matsuoka**, Tokyo, Japan

[73] **Assignee:** **Sony Corporation**, Tokyo, Japan

[\*\*] **Term:** **14 Years**

[21] **Appl. No.:** **58,655**

[22] **Filed:** **Aug. 20, 1996**

[51] **LOC (6) Cl.** ..... **14-01**

[52] **U.S. Cl.** ..... **D14/136**

[58] **Field of Search** ..... **D14/124, 135,**  
**D14/136, 156, 157, 160, 167; 361/379-681,**  
**683, 724; 369/75.1, 75.2, 77.1, 77.2, 213,**  
**270, 6, 7, 11, 12**

[56] **References Cited**

**U.S. PATENT DOCUMENTS**

|            |         |               |       |         |
|------------|---------|---------------|-------|---------|
| D. 339,123 | 9/1993  | Kasama et al. | ..... | D14/135 |
| D. 360,883 | 8/1995  | Ito et al.    | ..... | D14/107 |
| D. 368,908 | 4/1996  | Ikenaga       | ..... | D14/156 |
| D. 375,488 | 11/1996 | Ikenaga       | ..... | D14/107 |

|           |        |             |       |             |
|-----------|--------|-------------|-------|-------------|
| 5,337,464 | 8/1994 | Steffes     | ..... | 364/708.1 X |
| 5,593,220 | 1/1997 | Seid et al. | ..... | 361/724 X   |

**OTHER PUBLICATIONS**

"Sony Style". CDX-U606, p. 133, Summer 1993.

*Primary Examiner*—James Gandy  
*Assistant Examiner*—Cathron B. Matta  
*Attorney, Agent, or Firm*—Foley & Lardner

[57] **CLAIM**

The ornamental design for a disc recorder, as shown and described.

**DESCRIPTION**

FIG. 1 is a perspective view of a disc recorder showing my new design;  
FIG. 2 is a top plan view thereof;  
FIG. 3 is a left side elevational view thereof;  
FIG. 4 is a front elevational view thereof;  
FIG. 5 is a bottom plan view thereof;  
FIG. 6 is a right side elevational view thereof; and,  
FIG. 7 is a rear elevational view thereof.

**1 Claim, 2 Drawing Sheets**

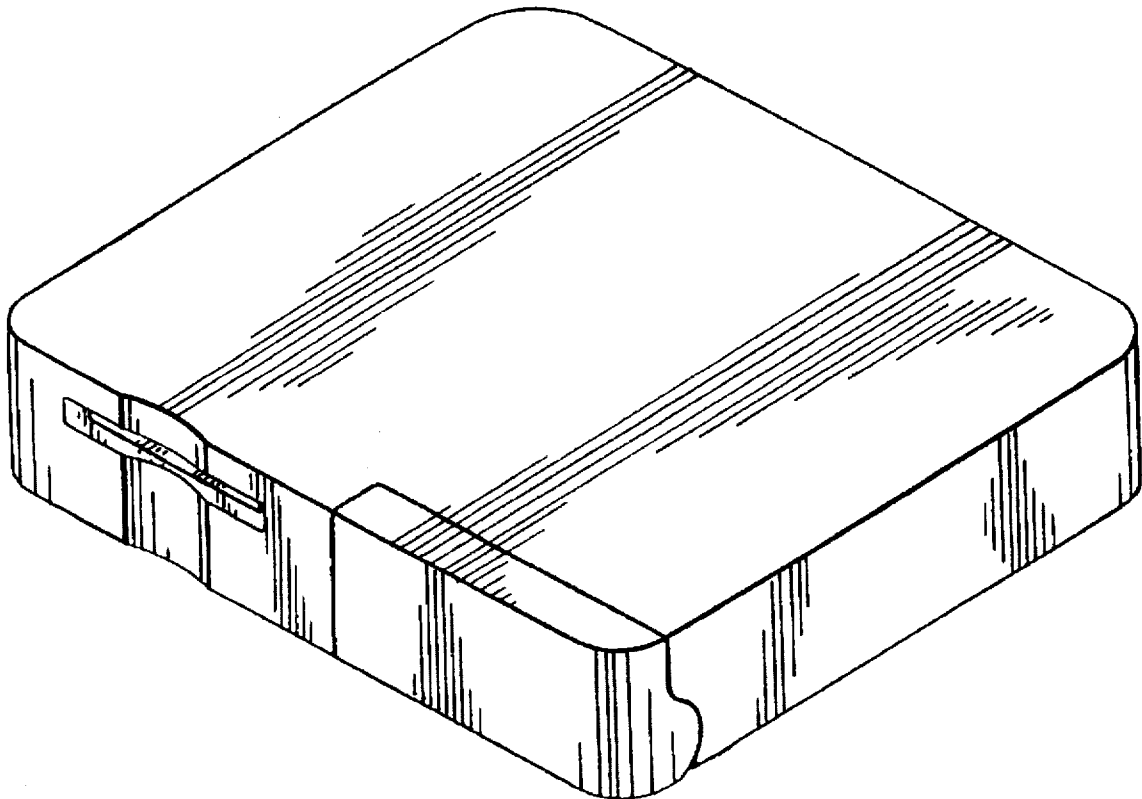

FIG. 1

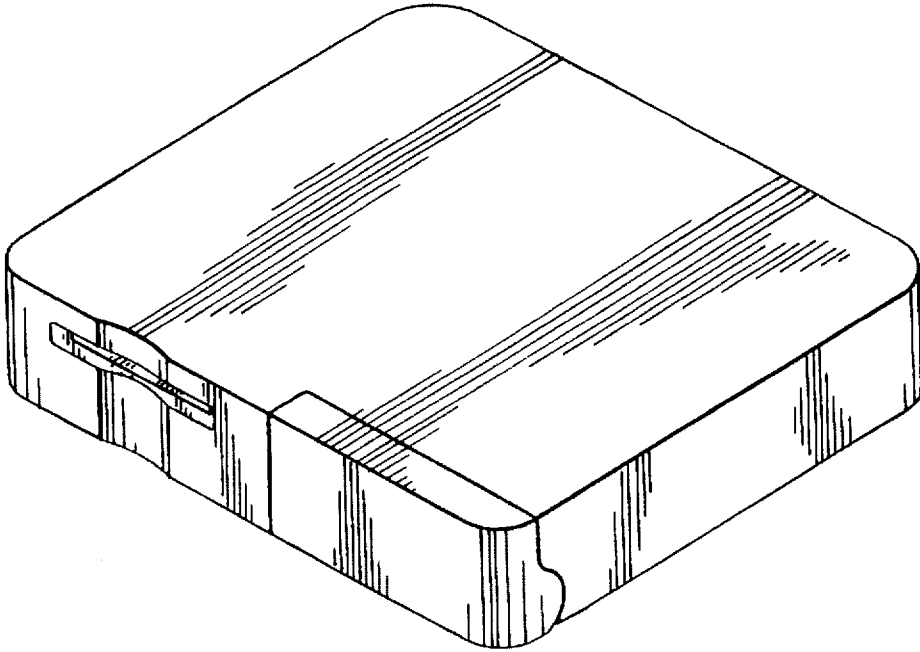

FIG. 2

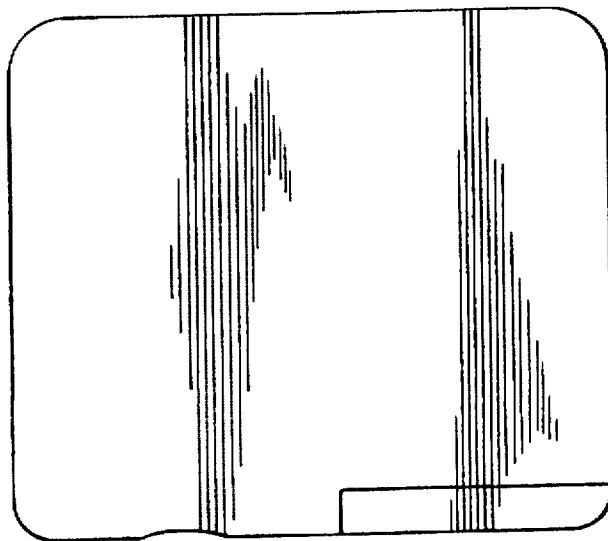

FIG. 3



FIG. 4

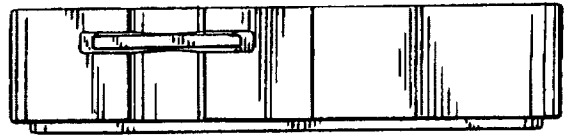

FIG. 5

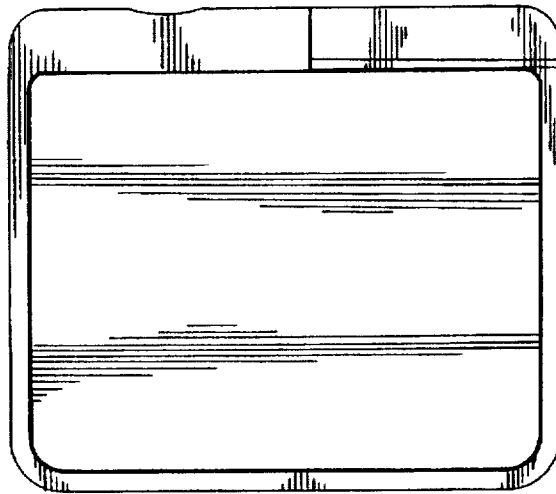

FIG. 6



FIG. 7

