

J. W. ESKHOLME.

CHECK VALVE.

No. 345,420.

Patented July 13, 1886.

Fig. 1.

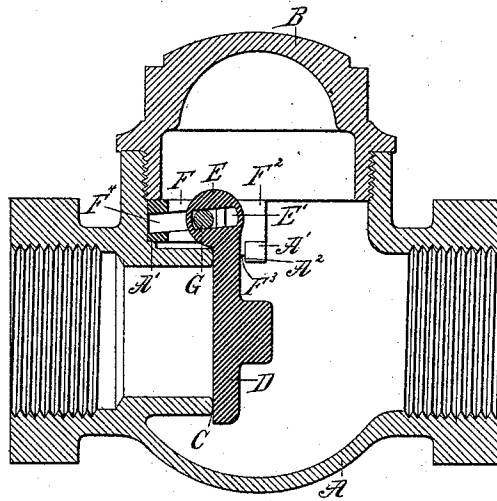

Fig. 2.

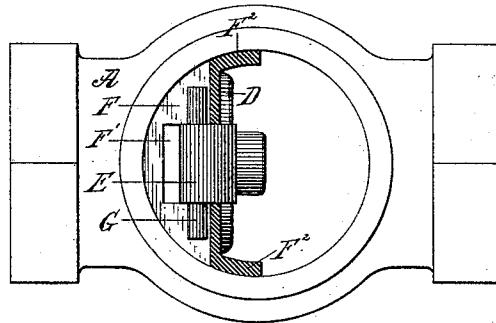

Fig. 3.

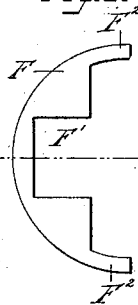
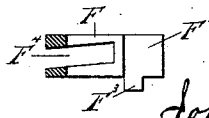

Fig. 4.



Witnesses

C. O. Perkins.
C. E. Ruggles.

Inventor,

John W. Eskholme.

By *A. M. Wooster*
Atty.

(No Model.)

2 Sheets—Sheet 2.

J. W. ESKHOLME.
CHECK VALVE.

No. 345,420.

Patented July 13, 1886.

Fig. 5.

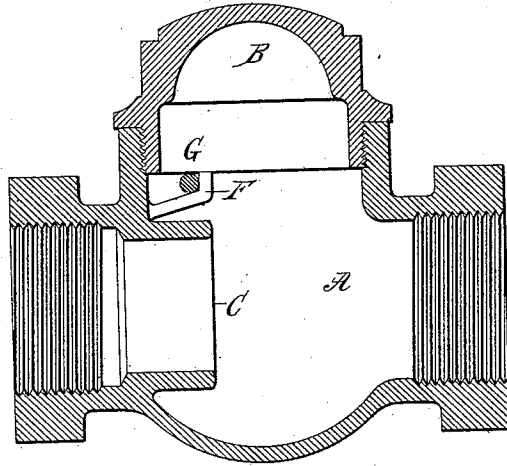
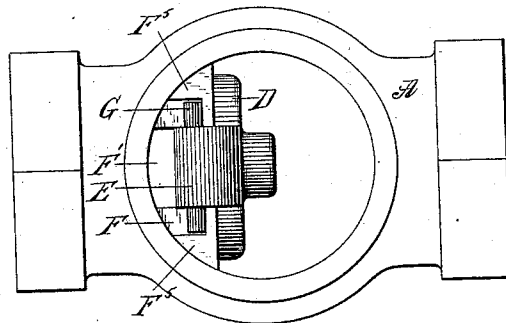

Fig. 6.



Witnesses,

C. C. Perkins.
C. E. Ruggles.

Inventor,

John W. Eskholme
By *A. M. Wooster*
att'y.

UNITED STATES PATENT OFFICE.

JOHN W. ESKHOLME, OF BRIDGEPORT, CONNECTICUT, ASSIGNOR OF ONE-HALF TO EDWARD J. KILEY, OF SAME PLACE.

CHECK-VALVE.

SPECIFICATION forming part of Letters Patent No. 345,420, dated July 13, 1886.

Application filed November 4, 1885. Serial No. 181,913. (No model.)

To all whom it may concern:

Be it known that I, JOHN W. ESKHOLME, a citizen of the United States, residing at Bridgeport, in the county of Fairfield and State of Connecticut, have invented certain new and useful Improvements in Check-Valves; and I do hereby declare the following to be a full, clear, and exact description of the invention, such as will enable others skilled in the art to which it appertains to make and use the same.

The object of my invention is to produce a valve of this class in which the disk shall be self-seating, and in which the wear of both disk and seat in use shall be fully compensated for. In order to accomplish this result I suspend the valve in such a manner that it shall be self-closing, and, moreover, shall be carried by a rolling pin, it being an essential requirement that the device as a whole shall be simple and economical in construction, durable, and practically impossible to get out of order. With these ends in view I have devised the novel construction of which the following description, in connection with the accompanying drawings, is a specification, similar letters in all the figures denoting the same parts.

Figure 1 is a central longitudinal section of the valve and case complete; Fig. 2, a plan view, the cap or cover being removed and the disk-carrier being in section; Fig. 3, a plan view of the disk-carrier detached; Fig. 4, a section of the disk-carrier on the line *xx* in Fig. 3; Fig. 5, a longitudinal section corresponding with Fig. 1, of a modified form, in which the disk-carrier is cast integral with the case, the disk being removed; and Fig. 6 is a plan view corresponding with Fig. 5, the cap being removed.

A is the case, and B a cap or cover screw-threaded to engage therewith. These parts may be of ordinary or any preferred construction.

C is the seat, and D the disk. I have shown the disk as made of metal and without packing, that being the form I preferably use. The style of disk, however, forms no portion of my invention, and packing may be used, if preferred.

The gist of my invention lies in the manner in which the disk is suspended.

E is the knuckle of the disk, which projects forward and is provided with a slot, *E'*, extending through it, which inclines forward and downward from near the back of the knuckle toward the front thereof, the face of the valve being considered the front.

F is the disk-carrier, which is a wholly novel feature of my invention, and is shown detached in Figs. 3 and 4.

F' is a recess in the carrier to receive the knuckle of the disk.

F² represents extensions at the back of the carrier, and F³ downwardly-projecting lugs on the under side of the extensions, the purpose of which will presently be explained.

F⁴ represents a slot in the carrier extending from the front toward the back, the direction thereof being upward and backward, and the plane thereof corresponding with the plane of slot *E'* in the knuckle—that is to say, the plane of these slots is at an angle to the plane of a longitudinal diameter of the case, the incline being upward from front to back—all of which will be more fully explained.

A' represents a horizontal flange or ledge in the case over the valve-seat, and extending backward from the front at both sides of the case to about the middle thereof. The disk is suspended upon a loose pin, G, which passes through slot *E'* in the knuckle of the disk, and the ends of which rest in slot F⁴ in the carrier, the pin being free to roll in said slots.

In use the knuckle of the disk is placed in recess F' in the carrier and the loose rolling pin passed through the slot in the knuckle and slot F⁴ in the carrier. The carrier and disk together are then dropped into the case, the carrier resting upon flange or ledge A', and lugs F³ upon the extensions of the carrier dropping into notches A² in the flange or ledge, as clearly shown in Fig. 1. The cover or cap is then screwed down to place, and rests upon the top of the carrier, or close to it, so that movement of the parts, with the exception of the desired movement of the rolling pin and the disk, is wholly prevented.

As stated above, the objects which I accom-

plish by my improved construction are simplicity and economy in construction, combined with great durability of the seat and disk. It will be seen that I have so arranged the pivotal point that the disk will close squarely upon the seat. This I accomplish by so constructing the knuckle that it will project forward of the face of the disk, so that the normal position of the pin in use is forward of the center of gravity of the disk, thus making the disk self-closing. It is of course desirable that all portions of the disk should come in contact with the seat at the same instant. This result is easily accomplished in any new valve; but as soon as wear of the disk or seat takes place (particularly if the disk is packed or made of softer metal than the seat) in valves as ordinarily constructed, all portions of the disk do not come in contact with the seat at the same time, and it is a serious fault in many valves that portions of the disk do not come in contact with the seat at all, thus causing a leakage and necessitating regrinding of the seat or disk or repacking of the disk. These objections I wholly overcome by suspending the disk forward of its center of gravity and using a rolling pin, which allows the disk sufficient movement in both the vertical and the horizontal plane to make it self-seating, even after the disk and seat have become considerably worn. This is a very valuable feature, as it avoids the necessity of throwing away the valve and substituting a new one or regrinding or repacking, the original cost being no more than that of ordinary valves, and the service secured thereby being much greater.

In the modified form illustrated in Figs. 5 and 6 the disk-carrier is not made removable, but is cast integral with the case, the plane of the carrier being inclined forward and downward, the same as slot F¹ in the other form. It will be noticed in Fig. 6 that at the opposite ends in the carrier I have provided abutments F⁵, against which the ends of the pins rest, and which hold the same against any possible lateral movement. This construction may of course be adopted in the form illustrated in Fig. 2, if desired. The disk used in this form is precisely the same as in the other form, although for convenience in illustration the disk is omitted in Fig. 5.

I do not desire to limit myself to the exact details of construction shown and described, as it is obvious that the construction may be widely varied without departing from the spirit of my invention.

Having thus described my invention, I claim—

1. The combination, with the seat and disk of a valve, of a knuckle upon the disk having a slot which inclines downward and forward from near the back toward the front thereof, a car-

rier within the case having a corresponding incline, and a rolling pin which passes through the slot in the knuckle and rests upon the carrier, whereby the disk is carried and movement of the disk is permitted to compensate for wear of the disk or seat. 65

2. The combination, with the seat and a disk having a knuckle with an inclined slot through it, of a carrier having an incline, and a rolling pin which passes through the inclined slot and rests upon the incline of the carrier, the location of said slot being such that gravity will act to close the valve. 70 75

3. The disk having a knuckle which projects forward of the face of the disk and has an inclined slot through it, the seat, and a carrier within the case having an incline corresponding with the incline of the slot, in combination with a loose pin which passes through the slot in the knuckle and is free to roll upon the incline of the carrier. 80 85

4. The disk having a knuckle which projects forward of the face of the seat and a slot through it which inclines downward and forward, in combination with the seat, a carrier within the case which is inclined to correspond with the slot, and is provided with abutments F⁵ at its opposite sides, and a loose pin which passes through the slot in the knuckle and rests upon the carrier between the abutments. 90 95

5. In a valve, the seat and a disk having a knuckle with an inclined slot through it, in combination with a removable carrier having an inclined slot, and a loose pin which passes through the slot in the knuckle and rests upon the carrier. 95 100

6. The case having a ledge, A', and the seat, in combination with a removable disk-carrier having a slot inclining forward and downward, which rests upon said ledge, the disk having a knuckle with an inclined slot, and a loose pin resting in a slot in the carrier, by which the disk is suspended. 105 110

7. In a valve, the combination, with the case having a ledge, A', the seat, the disk, and a loose rolling pin, of a removable disk-carrier having recess F' and slot F¹, by which the disk is suspended. 110 115

8. The case having a ledge, A', the seat, the disk having a knuckle with an inclined slot, the removable carrier, and a loose rolling pin, in combination with cap or cover B, adapted to screw down upon the carrier, whereby the parts are held in place in any position the valve may be caused to assume. 115

In testimony whereof I affix my signature in presence of two witnesses.

JOHN W. ESKHOLME.

Witnesses:

A. M. WOOSTER,
E. J. KILEY.