



(19) **United States**

(12) **Patent Application Publication**
Schiedegger et al.

(10) **Pub. No.: US 2001/0023173 A1**

(43) **Pub. Date: Sep. 20, 2001**

(54) **VENT APPARATUS**

(52) **U.S. Cl. 454/367**

(76) Inventors: **Charles E. Schiedegger**, Metamora, MI (US); **Mark T. MacLeod**, Rochester Hills, MI (US); **Michael C. Clark**, Columbiaville, MI (US)

(57) **ABSTRACT**

Correspondence Address:
Kevin S. MacKenzie
Suite 101
39400 Woodward Avenue
Bloomfield Hills, MI 48305-5151 (US)

A vent apparatus for cooperating with duct work associated with an exhaust fan to enable air to be exhausted from an interior room of a dwelling to the exterior environment. The vent apparatus includes a base member and a cover member releasably securable to the base member. The base member includes an attaching portion having a plurality of locking portions, while the cover member includes a plurality of flexible latching arm members which releasably engage the locking portions when the cover member is placed over the attaching portion. The attaching portion includes an enlarged opening which enables air exhausted from an interior room to be directed out between the base and cover members to the exterior atmosphere. The apparatus is particularly well-adapted to be used with vinyl or aluminum siding and is relatively inexpensive to construct, light-weight and easy to install. In an alternative embodiment, the apparatus includes a screen adapted to be secured to the base member. The screen has dimensions which enable it to fit within the cover member so as not to be visible once the cover is installed on the base member. The screen prevents insects and small mammals from entering through the base member. The screen is secured to the base member via a plurality of locking arm members which engage within openings formed in the base member such that the screen can be "snapped" onto the base member without special tools or external fastening elements such as threaded screws or the like.

(21) Appl. No.: **09/799,966**

(22) Filed: **Mar. 6, 2001**

Related U.S. Application Data

(63) Continuation of application No. 09/288,842, filed on Apr. 8, 1999, now Pat. No. 6,196,915, which is a continuation of application No. 09/132,272, filed on Aug. 11, 1998, now Pat. No. 5,947,816, which is a continuation of application No. 08/554,889, filed on Nov. 9, 1995, now Pat. No. 5,791,985, which is a continuation-in-part of application No. 08/468,191, filed on Jun. 6, 1995, now abandoned.

Publication Classification

(51) **Int. Cl.⁷ F24F 7/02**

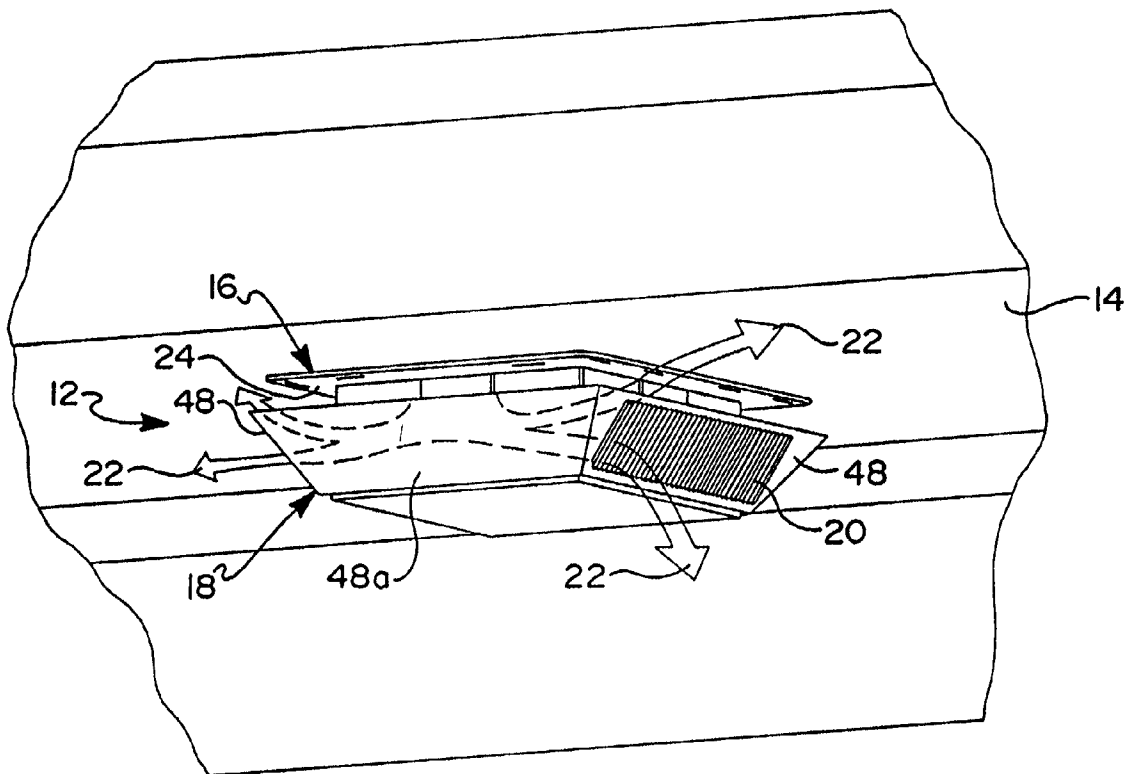

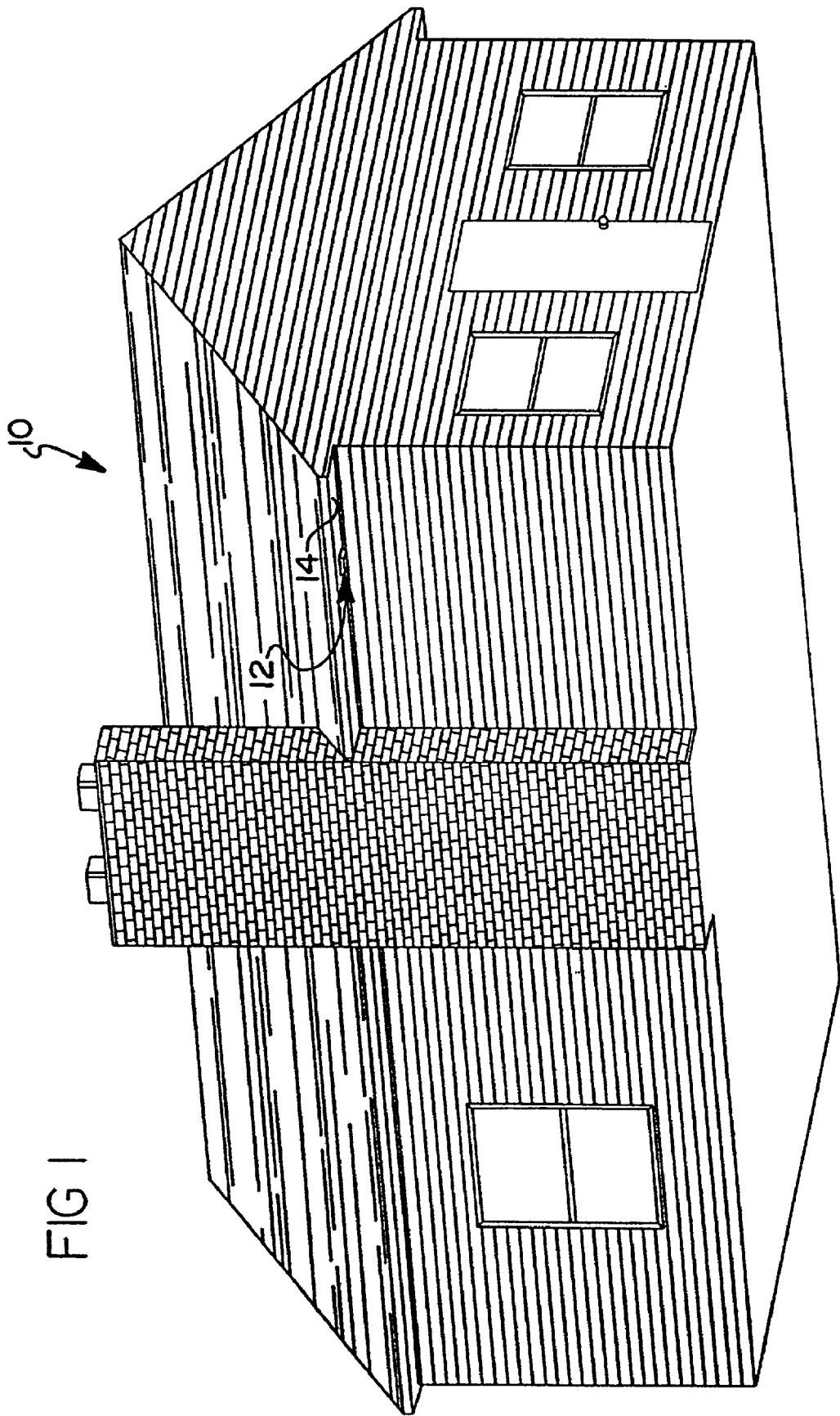
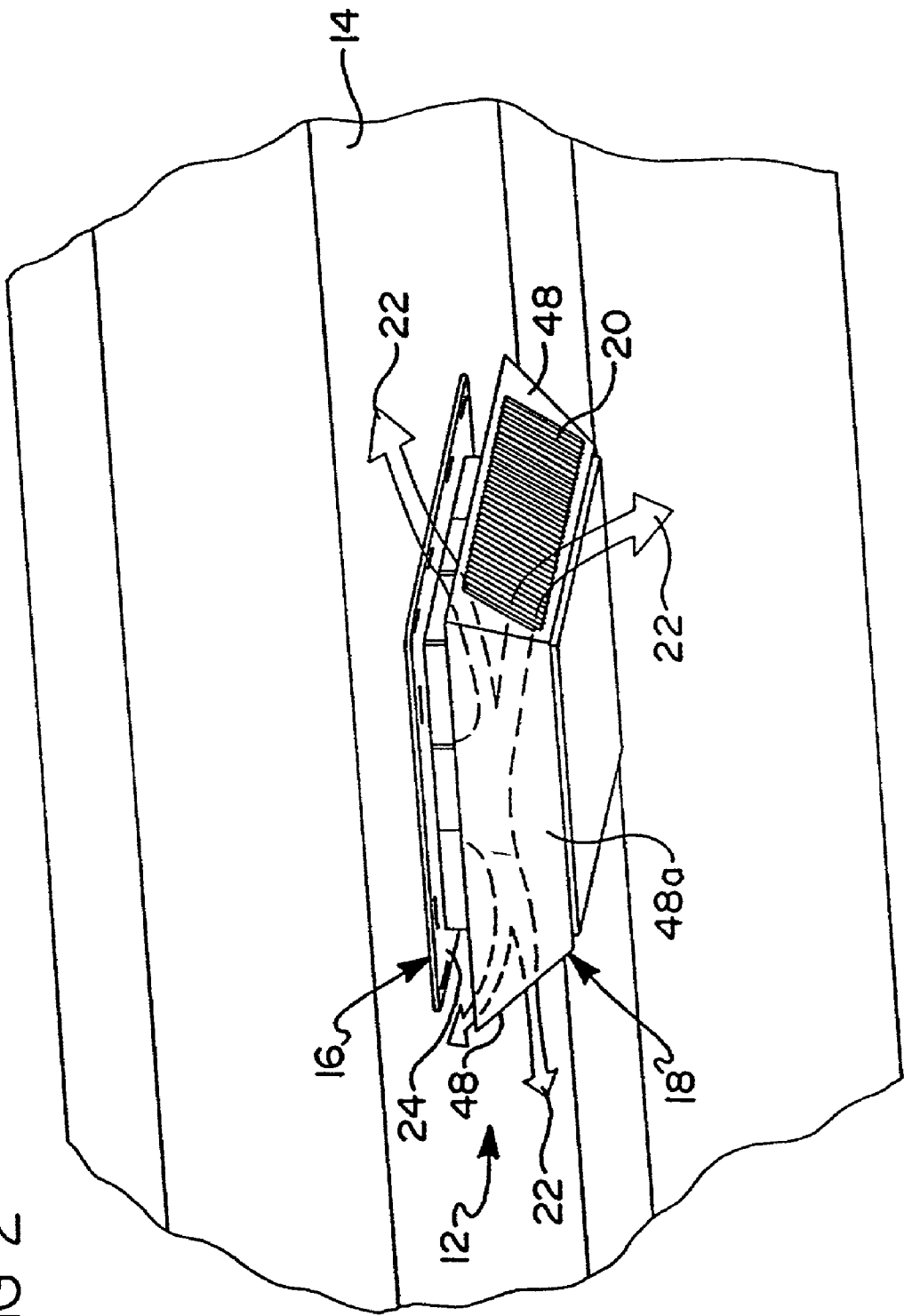

FIG 2



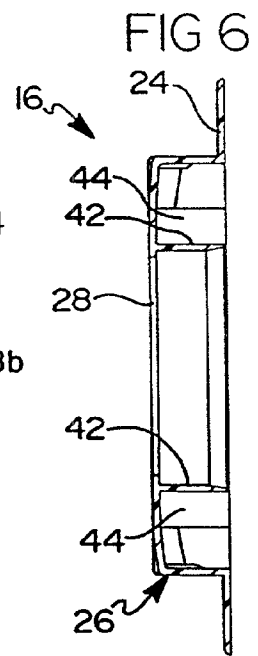
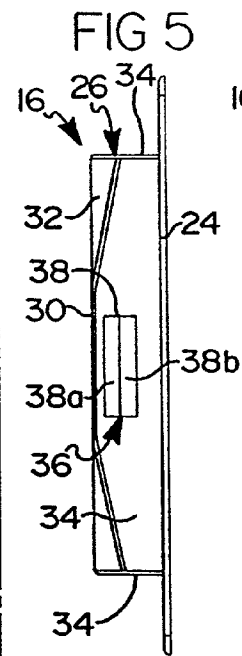
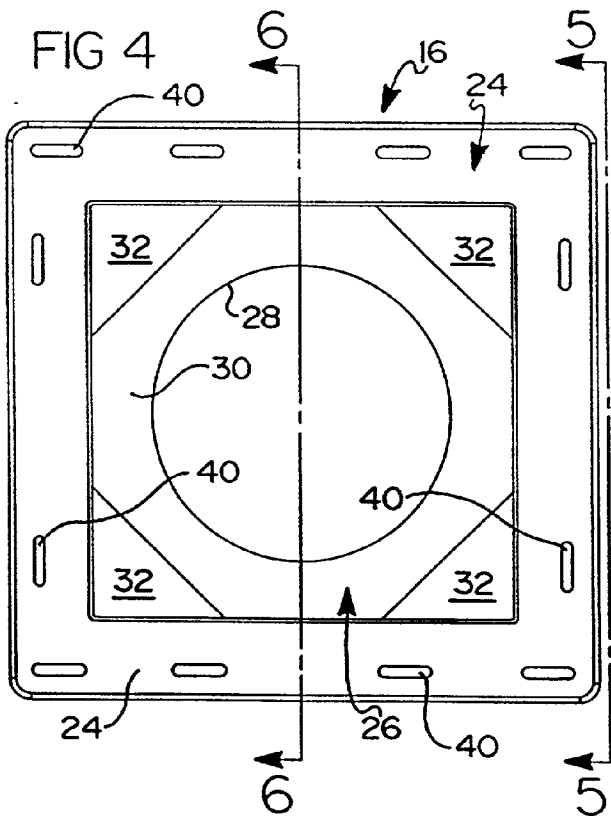
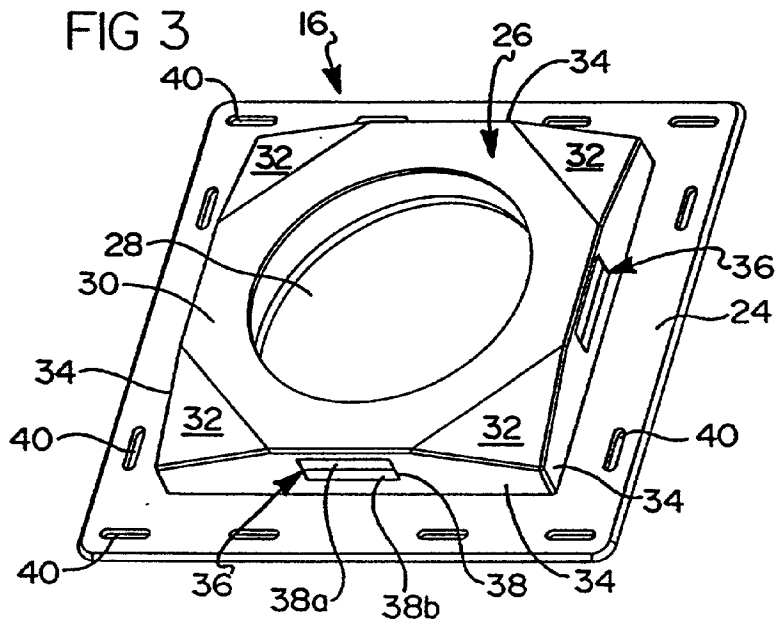

FIG 7

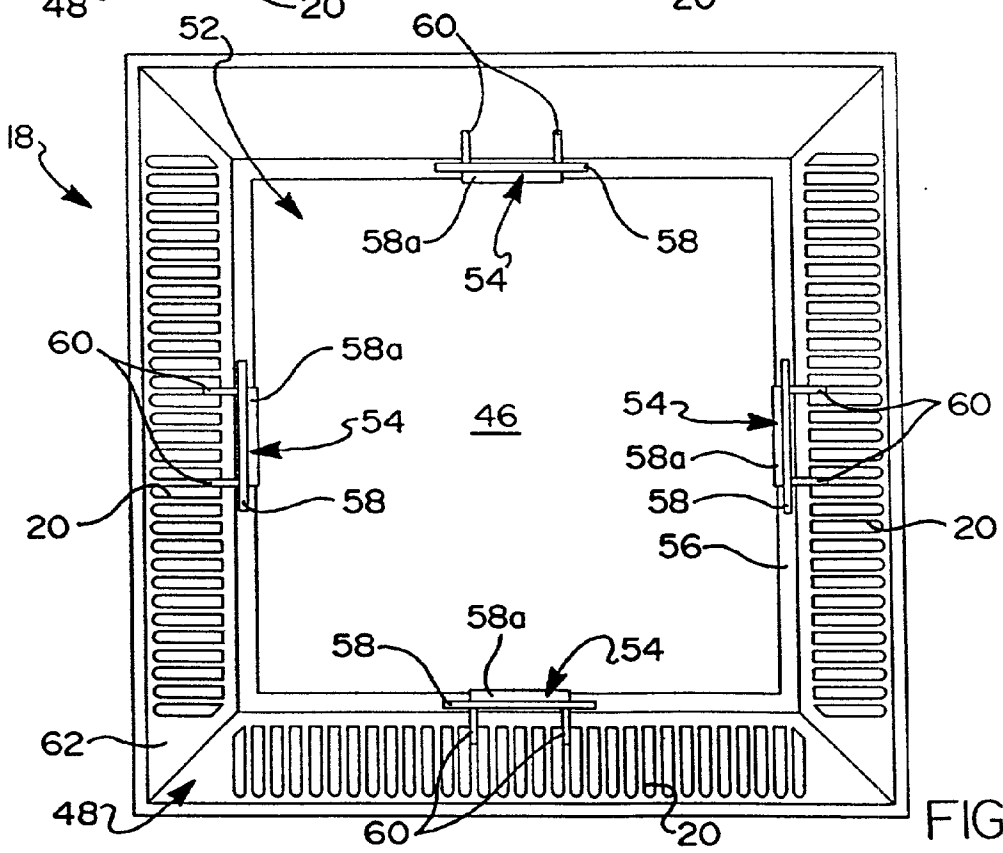
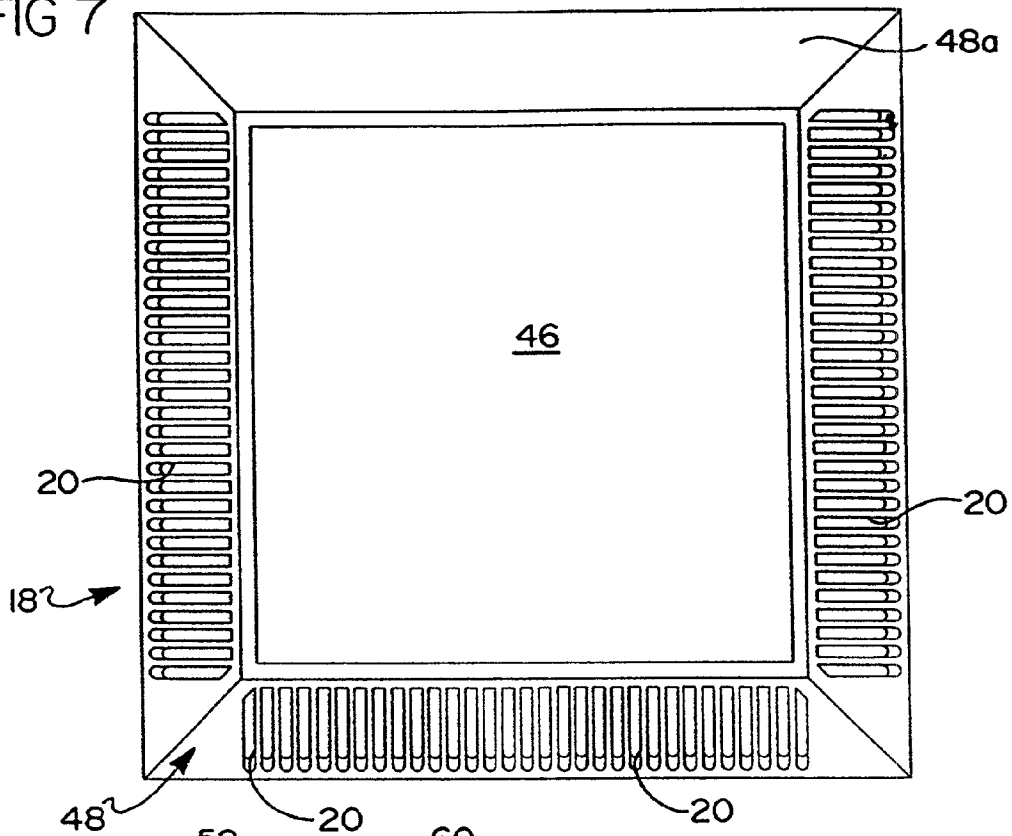

FIG 8

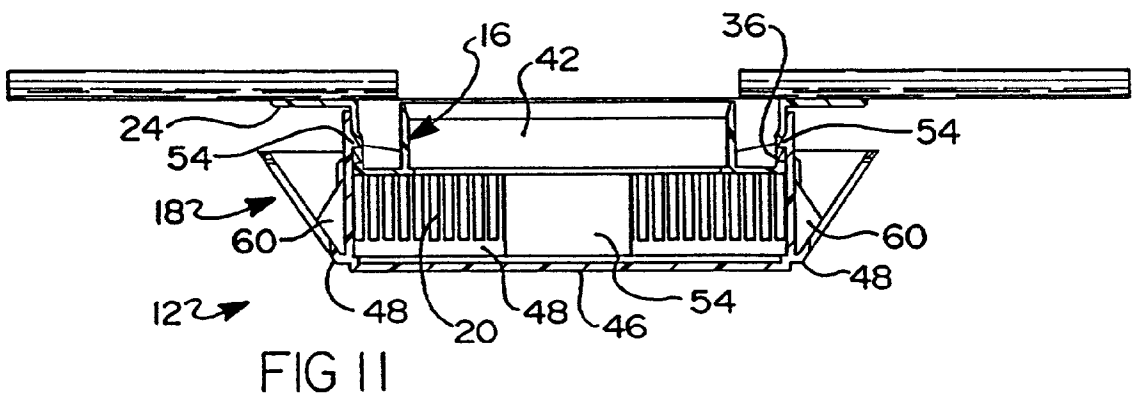
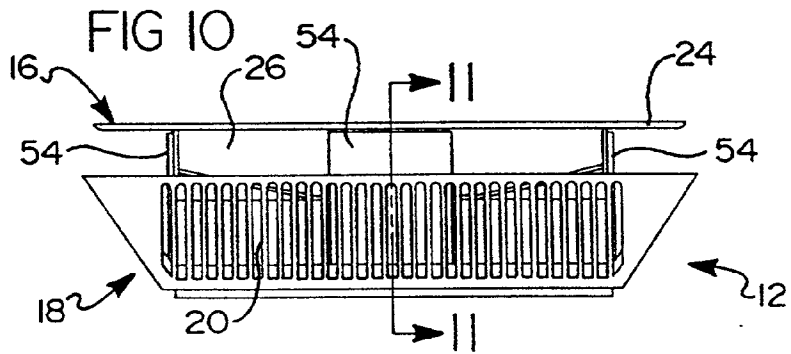
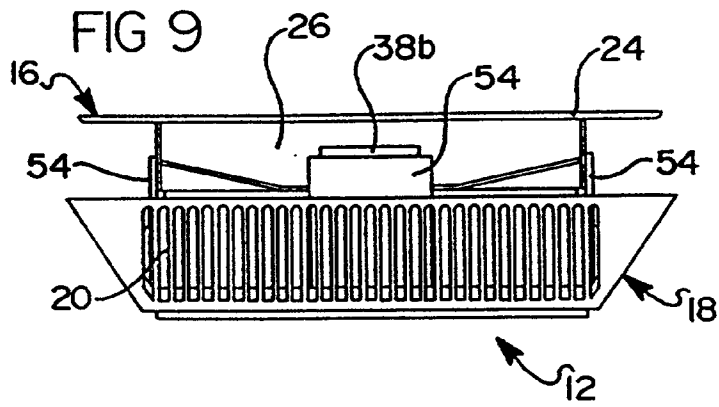
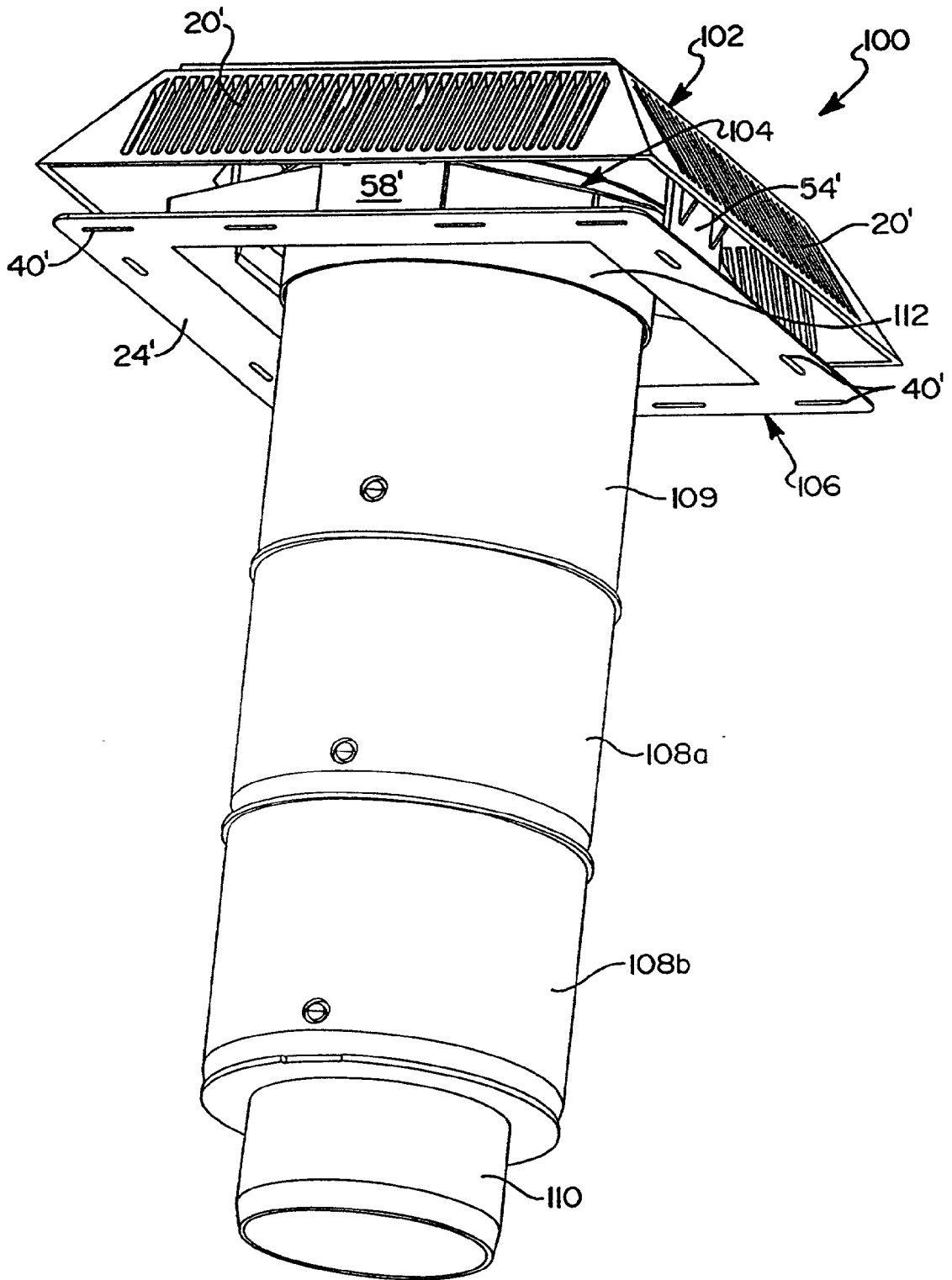

FIG 12



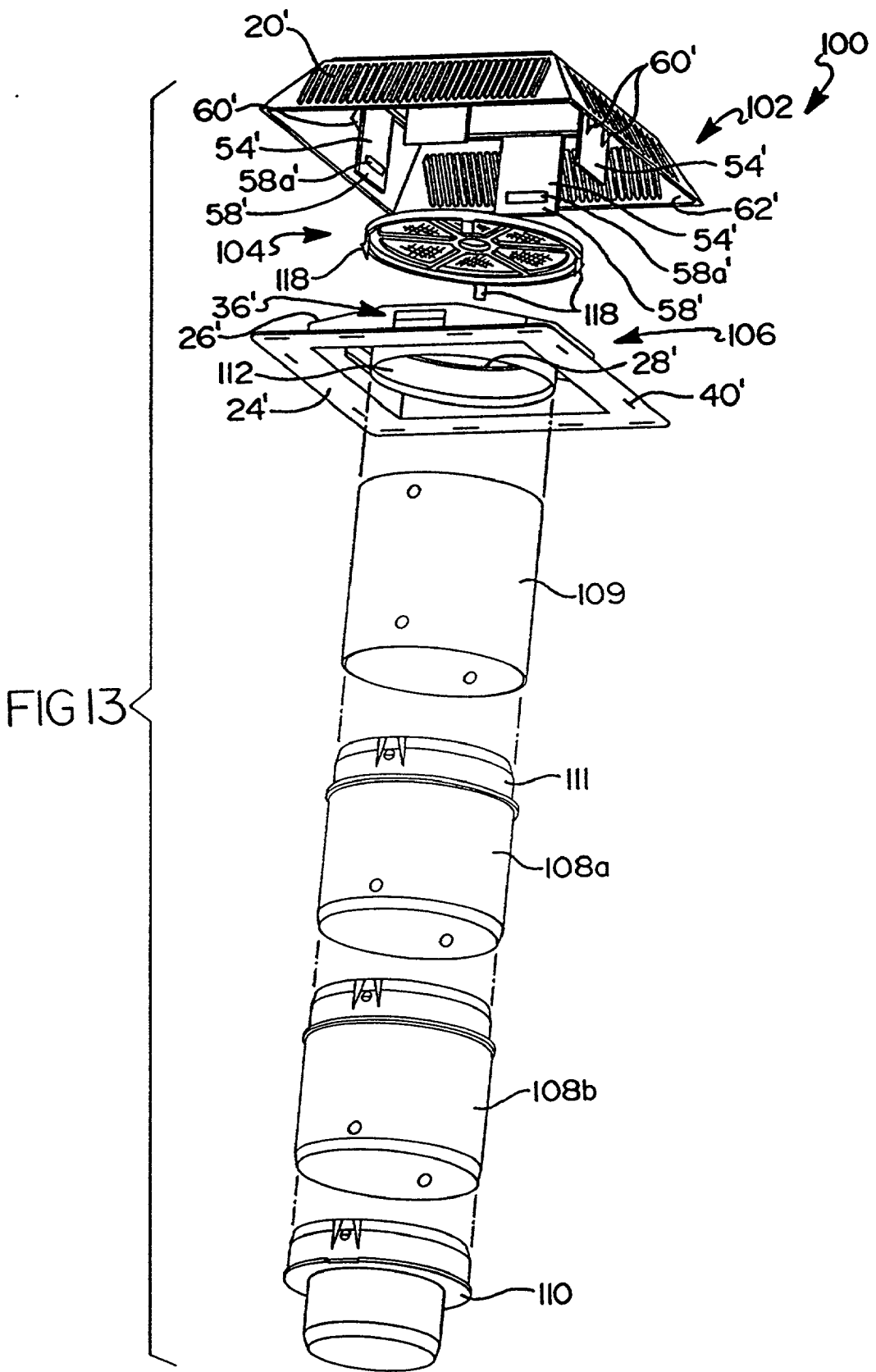

FIG 14

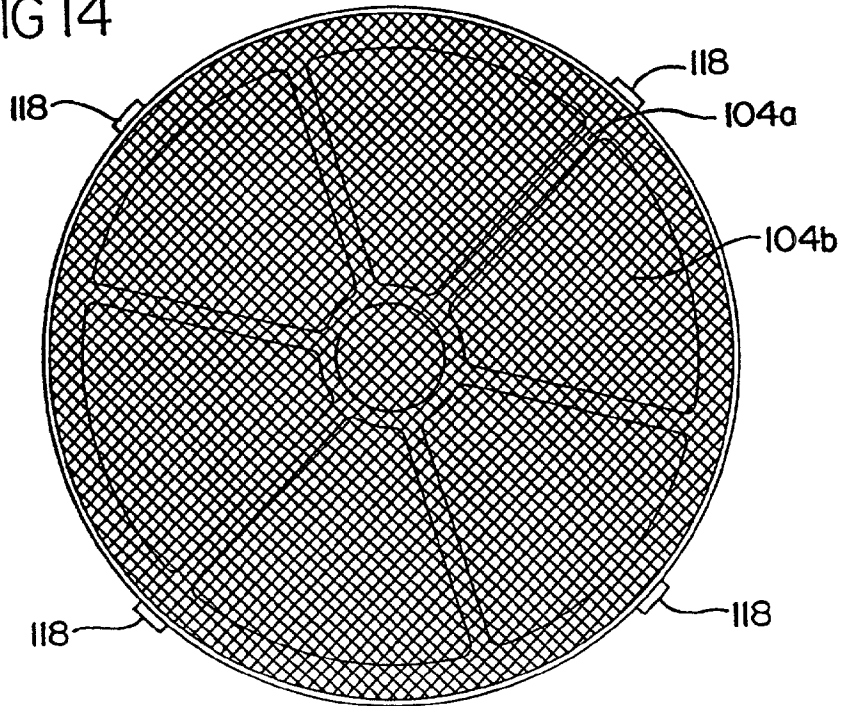

FIG 15

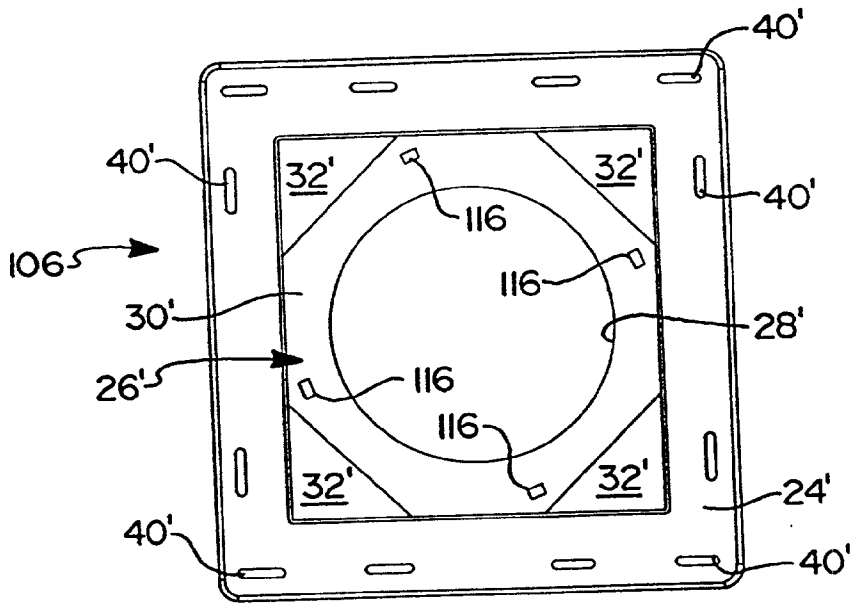
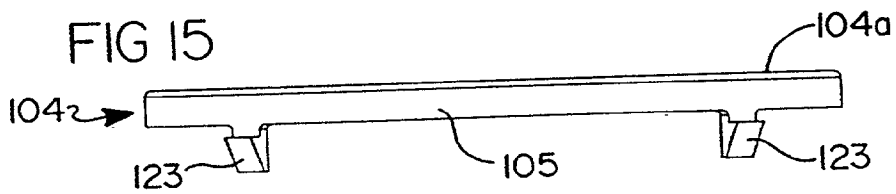
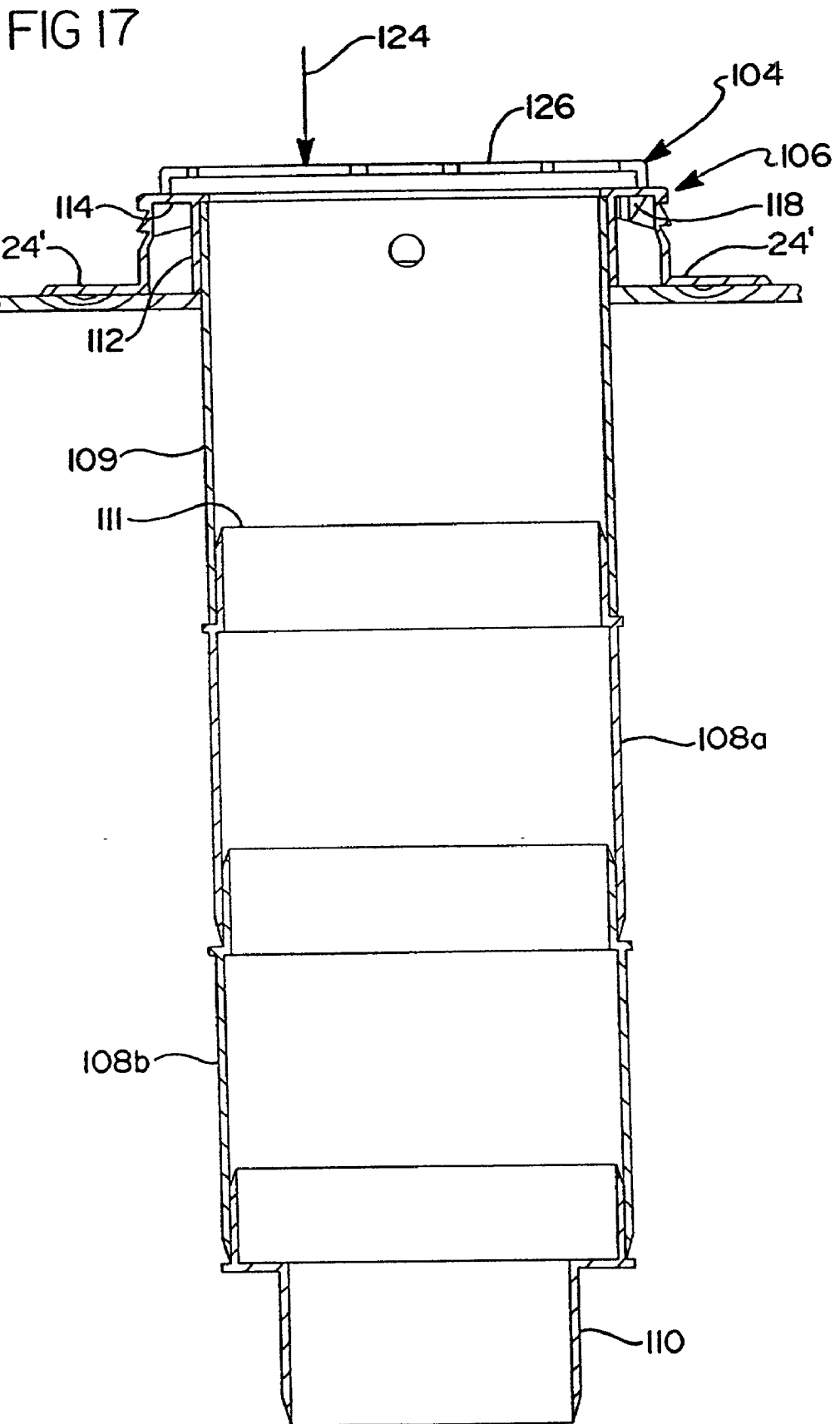

FIG 16



VENT APPARATUS

CROSS-REFERENCE TO RELATED APPLICATIONS

[0001] The subject matter of the present application is a continuation-in-part of U.S. patent application Ser. No. 08/468,191, filed Jun. 6, 1995, and entitled "Component Soffit Vent Apparatus", assigned to the assignee of the present application.

BACKGROUND OF THE INVENTION

[0002] 1. Technical Field

[0003] This invention relates to vent assemblies, and more particularly to a component soffit vent apparatus.

[0004] 2. Discussion

[0005] A variety of vent apparatuses are typically used in residential and commercial dwellings to allow ventilation of attics and other interior areas of the dwelling. In the past, with the bathroom areas of dwellings, it was common to vent air exhausted from a bathroom via a bathroom fan through duct work into an attic or other like area of a dwelling, and to allow the exhausted air to escape to the external environment through one or more roof vents or soffit vents associated with the roof of the dwelling.

[0006] Recently, building codes have been amended to require the air exhausted via a bathroom fan to be exhausted through an independent, dedicated vent. Hence, it is no longer permissible in many cities to vent air exhausted from a bathroom exhaust fan directly into an attic of the dwelling.

[0007] While various vent apparatuses exist which may be attached to an exterior surface of the dwelling such as a soffit and communicate with an exhaust fan disposed within one of the rooms of the dwelling, such apparatuses have often been somewhat cumbersome to install, expensive, or have added to the complexity of installing vinyl or aluminum siding in the area surrounding that where the vent apparatus is placed. In addition, many previously developed vent apparatuses are not easily suited to be retrofitted to existing dwellings when an additional interior exhaust fan is added to the dwelling that necessitates an independent vent for dedicated use therewith.

[0008] Accordingly, it is a principal object of the present invention to provide a soffit vent apparatus for use with an interior exhaust fan of a building such as a dwelling, which may be easily and quickly secured to an exterior surface of the dwelling such as a soffit.

[0009] It is another object of the present invention to provide a soffit vent apparatus which includes two component parts, one of which may be secured directly to an exterior surface of a building such as a soffit thereof, and the second part of which may be quickly and easily secured to the first part without the need for additional external fasteners or complicated assembly steps.

[0010] It is still a further object of the present invention to provide a soffit vent apparatus which may be positioned on a horizontally extending soffit of a building such as a dwelling, or alternatively, positioned on a vertically extending exterior surface of a building, to enable the exhausting of air from an interior exhaust fan of the building.

[0011] It is still another object of the present invention to provide a soffit vent apparatus which is well-suited to enabling the exhausting of air from an interior exhaust fan of a building, and which further is of a construction which enables it to be secured to an exterior surface of the building without complicating the addition of vinyl or aluminum siding to the areas immediately adjacent the vent apparatus.

[0012] It is still another object of the present invention to provide a soffit vent apparatus which is relatively inexpensive and easily constructed from conventional molding techniques, which is light-weight, resists weathering and the elements, and which may be installed on an exterior surface of the building with conventional fastening elements such as nails or wood screws.

SUMMARY OF THE INVENTION

[0013] The above and other objects are provided by a soffit vent apparatus in accordance with the preferred embodiments of the present invention. The apparatus comprises a base member having a securing flange and an attaching portion. The securing flange includes one or more openings for enabling the securing flange to be secured to an exterior surface of a building via conventional nails or wood screws. The attaching portion includes an opening of a suitable diameter to communicate with duct work associated with an exhaust fan disposed within an interior room of the building. One or more locking portions are also formed on the attaching portion.

[0014] An independent cover member is releasably securable to the base member via one or more securing members. The securing members preferably protrude from an interior surface of the cover member and interengage with the one or more locking portions of the base member to hold the cover member to the base member in spaced-apart relationship to enable exhaust air exiting the opening in the base member to pass out to the exterior environment between the base member and the interior of the cover member. The cover member is preferably of dimensions which enable it to completely cover the base member, thereby providing a decorative appearance and concealing the fastening elements securing the base member to the exterior surface of the building.

[0015] In a preferred embodiment, the attaching portion includes an uppermost surface having a generally square-shape and a plurality of corner portions sloping downwardly towards the securing flange. The downwardly sloping corner portions provide further clearance between the cover member and the base member when the cover member is secured to the base member, thereby enhancing the ease with which air may be exhausted through the opening, between the base member and the cover member, and to the external environment.

[0016] In a preferred embodiment, the attaching portion of the base member further includes a plurality of locking portions, with each locking portion including a plurality of integrally formed shoulder portions. In this preferred embodiment, a plurality of securing members are formed on an interior surface of the cover member. Each securing member comprises a flexible latching arm which is releasably engageable with an associated shoulder portion on the base member. The latching arms and the shoulder portions thus allow the cover member to be adjustably positioned in

spaced-apart relationship to the base member to provide an adjustable degree of clearance between the cover member and the base member.

[0017] In another preferred embodiment, the cover member includes a central portion and an angled peripheral portion. The peripheral portion is preferably angled such that it slopes downwardly towards the securing flange of the base portion. The peripheral portion includes a plurality of ventilation slots to even further increase the ease with which air may be exhausted to the exterior environment.

[0018] In an alternative preferred embodiment, the soffit vent apparatus comprises a base member which is securable to the exterior of a building over an opening in the exterior surface of the building. A screen is releasably secured to a portion of the base member. A cover member is releasably secured to the base member in spaced-apart relationship to the screen so as to enclose the screen. The screen prevents the entry of relatively small insects and other small mammals into the opening of the building.

[0019] In the just-described alternative preferred embodiment, the base member further includes a cylindrical member secured to the base member so as to protrude toward the opening in the building. The cylindrical member is of a diameter sufficient to accept duct work having a diameter up to at least about four inches. If duct work having a diameter of less than four inches is to be covered by the apparatus, then the apparatus is able to be used with an adapter member for mating the cylindrical member to the duct work. Accordingly, through the use of the adapter member, the soffit vent can be used to communicate with duct work having a diameter approximately equal to that of the cylindrical member or less than the diameter of the cylindrical member.

[0020] In each of the preferred embodiments, the base member and the cover member are molded through conventional molding techniques, and preferably injection molded, from a thermoplastic. The base member and cover member each form light-weight, yet rigid and strong component parts which are resistant to corrosion and the elements, and further which will not splinter, crack or otherwise show visible signs of wear over prolonged periods of time.

[0021] The vent apparatus of the present invention further enables aluminum or vinyl siding to be more easily installed after the vent apparatus is secured to the exterior surface of the building. This is because the siding need not be cut to perfectly and completely cover the securing flange of the base member, since the cover member is preferably dimensioned such that it extends completely over the base member, thus concealing the entire securing flange. The vent apparatus is further retrofittable to an existing building which already has vinyl or aluminum siding thereon without requiring entire lengths of siding to be removed before securing the base member to the exterior surface of the building.

BRIEF DESCRIPTION OF THE DRAWINGS

[0022] The various advantages of the present invention will become apparent to one skilled in the art by reading the following specification and subjoined claims and by referencing the following drawings in which:

[0023] FIG. 1 is a perspective view of a building in the form of a residential dwelling having a vent apparatus in accordance with the present invention attached to a soffit of the dwelling;

[0024] FIG. 2 is an enlarged perspective view of the vent apparatus shown in FIG. 1;

[0025] FIG. 3 is a perspective view of the base member of the present invention;

[0026] FIG. 4 is a plan view of the base member of FIG. 3;

[0027] FIG. 5 is a right side view of the base member of FIG. 4 taken in accordance with directional line 5-5 of FIG. 4;

[0028] FIG. 6 is a cross-sectional view of the base member of FIG. 4 taken in accordance with section line 6-6 of FIG. 4;

[0029] FIG. 7 is a plan view of the cover member of the vent apparatus of the present invention;

[0030] FIG. 8 is a plan view of the interior area of the vent apparatus of FIG. 7;

[0031] FIG. 9 is a side view of the cover member secured at a first mounting position to the base member;

[0032] FIG. 10 is a side view of the cover member secured to the base member in a second mounting position;

[0033] FIG. 11 is a cross-sectional side view of the assembled vent apparatus secured to the exterior surface of the building and taken in accordance with section line 11-11 of FIG. 10;

[0034] FIG. 12 is a perspective view of a soffit vent apparatus in accordance with an alternative preferred embodiment of the present invention;

[0035] FIG. 13 is an exploded perspective view of the various components of the soffit vent apparatus of FIG. 12;

[0036] FIG. 14 is a plan view of the screen of the soffit vent apparatus shown in FIG. 13;

[0037] FIG. 15 is a side view of the screen shown in FIG. 14 in accordance with directional line 15-15 in FIG. 14;

[0038] FIG. 16 is a plan view of the base member of the apparatus of FIG. 12; and

[0039] FIG. 17 is a cross-sectional side view of the screen secured to the base member, and also a section of duct work positioned within the cylindrical member.

DETAILED DESCRIPTION OF THE PREFERRED EMBODIMENTS

[0040] Referring to FIG. 1, there is shown a building in the form of a residential dwelling 10 and a vent apparatus 12 in accordance with the present invention secured to a soffit 14 of the dwelling 10. It will be appreciated immediately, however, that the vent apparatus 12 could just as easily be secured to a vertically extending surface of the building and is not limited to placement on a soffit of a building. Thus, while the vent apparatus 12 is referred to herein as a "soffit" vent apparatus, the apparatus 12 is securable to virtually any surface of the building where it may be attached by nails or threaded screws.

[0041] The vent apparatus 12 is well adapted to communicate with the duct work of an internal exhaust fan disposed within one of the rooms within the dwelling 10. The apparatus 12 communicates with an opening cut into the

soffit 14 or other surface of the dwelling 10, which is in communication with duct work leading to the exhaust fan within the dwelling, to thereby enable air exhausted from an interior room of the dwelling to pass outwardly through the duct work in the attic of the dwelling 10 and through the apparatus 12 to the outside atmosphere.

[0042] With reference to FIG. 2, the vent apparatus 12 generally comprises a base member 16 and a cover member 18 releasably securable to the base member 16. As will be explained more fully in the following paragraphs and in connection with the remaining drawing figures, the cover member 18, when secured to the base member 16, is positioned in a slightly spaced-apart relationship to the base member 16 to thereby permit air exhausted through the duct work of the dwelling to exit between the base member 16 and the cover member 18, as well as through ventilation slots 20 formed in the cover member 18, as indicated by airflow arrows 22.

[0043] Referring now to FIGS. 3-5, the base member 16 includes a generally planar securing flange 24 and an integrally formed, raised attaching portion 26. The attaching portion 26 includes a relatively large diameter opening 28 formed centrally therein, with the precise diameter of the opening 28 being variable, but preferably about 4.00 inches, to communicate with conventional ventilation duct work. The attaching portion 26 is illustrated as being generally square in shape, but may just as easily be formed of a circular, triangular, oval or other rectangular shape if so desired. The attaching portion 26 includes an uppermost surface 30 having corner portions 32 which slope downwardly towards the securing flange 24. The attaching portion 26 further includes sidewalls 34 which each include a locking portion 36 integrally formed thereon. Each locking portion 36 is comprised of a plurality of integrally formed shoulder portions 38, the function of which will be described momentarily. The securing flange 24 extends generally perpendicularly from the sidewalls 34 and includes a plurality of spaced-apart openings 40 in the form of elongated slots spaced thereabout to provide openings for nails, threaded screws or other like fasteners to pass therethrough to secure the securing flange 24 directly to the exterior surface of the soffit 14. The elongated shape of the openings 40 further provides a degree of added adjustability when positioning the base member 16 during installation, as well as for allowing for thermal expansion of the base member 16 once the base member 16 is secured to the soffit 14. With specific reference to FIG. 6, the base member 16 includes an interior circular wall portion 42 reinforced by one or more interior brace portions 44 integrally formed with the circular wall portion 42 and the uppermost surface 30.

[0044] Referring now to FIG. 7, the cover member 18 includes a central portion 46 and a downwardly angled peripheral portion 48. By downwardly angled, it is meant that the peripheral portion 48 slopes downwardly towards the securing flange 24, as indicated in FIG. 2.

[0045] The peripheral portion 48 preferably includes the plurality of elongated ventilation slots 20 formed around the peripheral portion 48 to enhance the ease with which air may be exhausted into the outside atmosphere. It will be appreciated that while the cover member 18 is shown having a generally square shape, it could also just as easily be circular in shape, oval-shaped or a wide-variety of other shapes to

provide a desired aesthetic appearance. It will also be noted that the ventilation slots 20 are preferably omitted from a portion of the peripheral portion 48. This is to enable the cover member 18 to be installed on a horizontal wall portion of the dwelling 10 without providing upwardly facing openings for water to enter the interior area of the cover member 18. Accordingly, the cover member 18, shown in FIG. 7, would be installed with the peripheral portion 48a facing up to thus help prevent water from entering the interior area of the cover member 18.

[0046] Referring now to FIG. 8, the structure of the internal area 52 of the cover member 18 can be seen. A plurality of securing members 54 are integrally formed with an interior surface 56 of the cover member 18. The securing members 54 are further spaced-apart from one another such that they reside along each one of the four quadrants of the peripheral portion 48 and protrude outwardly generally perpendicular to the central portion 46. Each securing member 54 comprises a flexible latching arm 58 having a lock bead 54a which is adapted to releasably interengage with the integrally formed shoulder portions 38 on the base member 16, as will be explained more fully momentarily. Each of the securing members 54 is further supported by a pair of braces 60 which are integrally formed with an interior surface 62 of each quadrant of the peripheral portion 48. The cover member 18 is molded, and preferably injection molded, as a single piece component from a suitably high-strength plastic such as polypropylene or polystyrene.

[0047] Referring now to FIG. 9, the cover member 18 is shown in a first mounting position secured to the base member 16. In this position, the flexible latching arms 58 are interengaged with a first one 38a of the shoulder portions 38 (FIG. 3), to thereby position the cover member 18 in a first position at a first distance from the securing flange 24. Pushing the cover member 18 further toward the securing flange 24 causes the flexible latching arms 58 to engage a second one 38b of the integrally formed shoulder portions 38, to thereby place the cover member 18 in a second position even closer to the securing flange 24. The interengagement of the flexible latching arms 58 and the shoulder portions 38 are shown in cross-section in FIG. 11.

[0048] The vent apparatus 12 is secured to the exterior surface of the dwelling 10 (FIG. 1) by first positioning the base member 16 over a pre-cut opening (not shown) in the soffit 14 or other area of the dwelling 10. The securing flange 24 is then secured by nails or conventional threaded screws to the exterior surface of the dwelling 10. The cover member 18 may then be positioned over the base member 16 and a slight force exerted on the central portion 46 of the cover member 18 to cause the lock beads 58a of the flexible latching arms 58 to engage with the locking portions 36 of the base member 16. At this point, the cover member 18 is releasably secured to the base member 16. By releasably secured it is meant that the cover member 18 may be removed by simply pulling outwardly on the cover member 18 to urge the cover member 18 away from the base member 16.

[0049] Referring now to FIG. 12, there is shown a soffit vent apparatus 100 in accordance with an alternative preferred embodiment of the present invention. The apparatus 100 generally comprises a cover member 102, a screen 104 and a base member 106. In the drawing of FIG. 12, a three

inch length of duct work **109** is shown fixedly secured to the base member **106** such as by spin welding. Two additional three inch lengths of duct work **108a** and **108b** are also shown coupled to each other and to the length of duct work **109**, together with an adapter **110** shown secured to the duct work length **108b**. It will be appreciated, immediately, that the two lengths of duct work **108a** and **108b** provide for a total length of six inches, which when added with the three inch length **109** provides a total length of nine inches, which is long enough to extend through a standard six inch thick wall. The adapter **110** serves as a reducer to enable the four inch diameter section of **108b** to be coupled to a three inch diameter section of duct work. Thus, the sections of duct work **108a** and **108b** allow the apparatus **100** to be used with walls having varying thicknesses.

[0050] Referring to FIG. 13, the cover member **102** is identical in construction to the cover member **18** shown in FIGS. 7 and 8. Accordingly, like portions of the cover member **102** have been designated with the same reference numerals used in FIGS. 7 and 8, but with the addition of a prime ("'") designator. The base member **106** is also substantially identical to the base member **16** shown in FIGS. 3-6. Accordingly, the reference numerals for the various portions of the base member **106** conform to those used in FIGS. 3-7, but with a prime designator added to each numeral.

[0051] With further reference to FIG. 13, one difference between the base member **106** (shown in FIG. 13) and the base member **16** (shown in FIGS. 3-6) is the addition of a cylindrical member **112** secured to an inner surface **114** of the base member **106** in such a manner so as to project generally perpendicularly outwardly from the inner surface **114**. With brief reference to FIG. 16, the uppermost surface **30'** of the base member **106** also includes a plurality of openings **116** spaced generally equidistant from one another.

[0052] With further reference to FIGS. 13-15, the screen **104** is shown in greater detail. It is a principal advantage of the apparatus **100** that the screen **104** is able to prevent the entry of small insects such as flies, bees, and even very small mammals into the duct work **108**. The screen **104** is manufactured by injection molding a suitably high-strength plastic such as polypropylene or polystyrene together with a section of conventional screen such as aluminum or fiberglass screening, placed in the mold tool. The resulting screen **104** comprises an integrally formed high-strength plastic frame **104a** having screening **104b** molded in-between the members of the frame **104a**. Alternatively, the screening **104b** could be secured over the frame **106** by appropriate threaded fasteners or even adhesives. It will, therefore, be appreciated that the screening **104b** could be secured to the frame **104a** through a variety of methods.

[0053] With further reference to FIGS. 14 and 15, and particularly to FIG. 14, the screen **104** includes integrally formed locking arms **118** spaced generally equidistant from one another about the outermost periphery **105** of the frame **104a**. The locking arms **118** are slightly resilient to allow for a small degree of deflection when the screen **104** is secured to the base member **106**. With specific reference to FIG. 15, each locking arm **118** includes a ledge portion **120** which protrudes outwardly just slightly of an outer peripheral edge portion **122** of the screen **104**. An angled portion **123** on each locking arm **118** also helps to allow the locking arms **118** to be secured to the base member **106**.

[0054] The screen **104** can be readily removed once engaged with the base member **106** for cleaning. It is releasable in that it can be disengaged with the end of a screwdriver or other like tool by pressing inwardly on the locking arms **118** while lifting the screen **104** away from the base member. Thus, if for some reason it becomes necessary to gain access to the interior of the duct work **108** or to clean the screen **104**, the screen **104** can be removed.

[0055] With reference to FIG. 17, the screen **104** is secured to the base member **106** by aligning the screen **104** such that the locking arms **118** are positioned over the openings **116** in the base member **106**. A downward force in accordance with directional arrow **124** is then applied to a top portion **126** of the screen **104** which causes each of the locking arms **118** to be deflected radially inwardly as the angled portions **123** each are urged along edges of the openings **116**. When the angled portions **123** pass completely past the openings **116**, the resiliency of each locking arm **118** causes it to snappingly engage within its associated opening **116**. Once secured to the base member **106**, the screen **104** cannot be readily removed or otherwise uncoupled from the base member **106** due to the interfering relationship of the ledge portions **120** with the openings **116**. Most importantly, the screen **104** prevents the entry of insects such as bees, wasps, flies and even very small mammals through the opening **28'** in the base member **106**.

[0056] With further reference to FIG. 17, the cylindrical member **112** has an inner diameter sufficiently large to accept a four inch diameter section of duct work **108** therein. Of course, it will be appreciated that the cylindrical member **112** could be formed having other diameters. However, a diameter sufficient to accept a four inch section of duct work, which is common in residential and commercial buildings, enables not only four inch duct work to be quickly coupled to the base member **106**, but also smaller diameter sections of duct work to be coupled through the use of the adapter **110** shown in FIGS. 12 and 13. The cylindrical member **112** is preferably spin-welded onto the inner surface **114** (FIG. 17) of the base member **106**, but it will be appreciated that it could also be integrally formed with the base member **106** during a molding process. Similarly, the length of duct work **109** is preferably spin-welded onto the interior surface of the cylindrical member **112**.

[0057] To assemble the apparatus **106**, the base member **106** is aligned over the section of duct work **108a** such that an outer edge portion **111** (FIG. 13) of the duct work **108a** is aligned with the length of duct work **109** and inserted into the length of duct work **109**. The length of duct work **108b** may then be coupled to length **108a** in the same manner, and the adapter **110** then coupled to duct work section **108b**. The securing flange **24'** is then positioned flush against the exterior of the building with the assembled lengths of duct work **108a** and **108b**, and adapter **110** extending into the opening in the building exterior. The securing flange **24'** is then secured to the exterior surface of the building by nails or threaded screws placed through the openings **40'**. The screen **104** can then be secured to the base member **106** as described herein. Subsequently, the cover member **102** is secured to the base member **106** so as to enclose the screen **104** between it and the base member **106**. The apparatus **100** thus forms a compact, relatively inexpensive and simple to assemble assembly which effectively prevents the intrusion of flying insects and other small mammals into the duct work

coupled to the apparatus **100**. Importantly, the screen **104** of the apparatus **100** does not add appreciably to the overall outer dimensions of the apparatus, its cost or complexity of assembly.

[**0058**] The preferred embodiments of the present invention thus forms a light-weight, relatively inexpensive and yet easy to manufacture and install assembly which may be used to help direct air exhausted from interior rooms of a dwelling to the external atmosphere, or simply used as a vent. The preferred embodiments are also each compact and can be installed without special and/or expensive tools.

[**0059**] Those skilled in the art can now appreciate from the foregoing description that the broad teachings of the present invention can be implemented in a variety of forms. Therefore, while this invention has been described in connection with particular examples thereof, the true scope of the invention should not be so limited since other modifications will become apparent to the skilled practitioner upon a study of the drawings, specification and following claims.

What is claimed is:

1. A vent apparatus comprising:
 - a base member having a securing flange for securing said base member to an exterior surface of a dwelling;
 - an attaching portion protruding outwardly from said securing flange, said attaching portion having an opening and a locking portion;
 - a cover member having a securing member and being of dimensions for enabling said cover member to be positioned at least partially over said attaching portion of said base member; and
 - said securing member of said cover member being engageable with said locking portion of said base member to secure said cover member to said locking portion such that said cover member is spaced-apart from said attaching portion to allow airflow through said opening and outwardly between said base member and said cover member.
2. The apparatus of claim 1, wherein said securing flange comprises a planar flange having a plurality of openings formed therein for enabling said planar flange to be secured to said exterior surface of said dwelling.
3. The apparatus of claim 2, wherein said openings comprise elongated slots spaced-apart from one another about said planar flange.
4. The apparatus of claim 1, wherein said locking portion comprises at least one integrally formed shoulder portion protruding from said attaching portion.
5. The apparatus of claim 4, wherein said securing member of said cover member comprises a flexible latching arm adapted to interengage with said shoulder portion of said base member to enable said cover member to be releasably secured to said base member.
6. The apparatus of claim 1, wherein said attaching portion comprises:
 - a generally square-shaped, raised portion having an uppermost surface; and
 wherein said uppermost surface includes a plurality of corner portions sloping downwardly towards said securing flange.

7. The apparatus of claim 1, further comprising a screen interposed between said base member and said cover member for restricting entry of insects and small mammals into said base member without impeding airflow through said apparatus.

8. The apparatus of claim 7, wherein said cover member comprises a frame having a plurality of projecting locking arm members; and

wherein said base member includes a plurality of openings in alignment with said locking arm members such that said locking arm members can be secured within said openings to thereby enable said screen to be secured to said base member.

9. A vent apparatus comprising:

a base member having an attaching portion having a securing flange and a plurality of openings spaced-apart from one another along said securing flange, said securing flange enabling said base member to be secured to an exterior surface of a structure;

said base member further including a raised attaching portion integrally formed with said securing flange, said raised attaching portion having a central opening and a plurality of locking portions; and

a cover member adapted to be placed over said base member and having dimensions sufficiently large to cover said base member, said cover member including a plurality of securing members adapted to releasably engage with said locking portions of said base member in a manner to secure said cover member in spaced-apart relationship to said base member to allow airflow through said opening of said base member, and outwardly between said base member and said cover member.

10. The apparatus of claim 9, wherein said openings each comprise an elongated slot.

11. The apparatus of claim 9, wherein said locking portions each include a plurality of shoulder portions integrally formed with said attaching portion.

12. The apparatus of claim 9, wherein said attaching portion comprises a generally square-shaped portion having a plurality of corner portions sloping downwardly toward said securing flange.

13. The apparatus of claim 9, wherein said securing member of said cover member comprises a flexible latching arm adapted to releasably engage with a respective one of said integrally formed, protruding shoulder portions of said base member.

14. The apparatus of claim 9, wherein said cover member comprises:

a central portion; and

a downwardly sloping peripheral portion, said peripheral portion having a plurality of openings formed therein to further facilitate airflow from said opening outwardly of said cover member to an external environment.

15. The apparatus of claim 9, wherein said base member is injection molded from a thermoplastic.

16. The apparatus of claim 9, wherein said cover member is injection molded from a thermoplastic.

17. The apparatus of claim 9, further comprising a screen positioned between said base member and said cover mem-

ber for restricting the entry of insects and small mammals into said base member without impeding airflow through said apparatus.

18. The apparatus of claim 17, wherein said screen comprises:

a frame having a plurality of projecting locking arms;

wherein said base member includes a plurality of openings formed therein so as to align with said locking arm members to thereby enable said screen to be secured to said base member in close proximity to said base member; and

said screen being completely covered by said cover member when said cover member is secured to said base member so as not to be visually apparent once said apparatus is secured to said exterior surface of said structure.

19. The apparatus of claim 9, wherein said base member further comprises a cylindrical portion positioned to extend from said central opening for accepting a section of external duct work therein.

20. A vent apparatus for communicating with ventilation duct work of a dwelling, said apparatus comprising:

a base member having a securing flange and an attaching portion integrally formed with said securing flange, said securing flange including a plurality of openings spaced-apart there along to enable said securing flange to be secured via external fastening members to an exterior surface of said dwelling;

said attaching portion including an opening and a plurality of integrally formed locking portions spaced about said attaching portion, said attaching portion further protruding outwardly of said securing flange; and

a cover member having dimensions sufficiently large to cover said base member and including a plurality of flexible latching arms protruding from an interior surface thereof, said latching arms being operable to releasably engage with said locking portions of said base member to secure said cover member in spaced-apart relationship to said base member to thereby permit airflow outwardly of said opening in said base member and between said cover member and said base member.

21. The apparatus of claim 20, wherein each of said locking portions of said base member includes at least one integrally formed shoulder portion for releasably engaging with an associated one of said flexible latching arms of said cover member.

22. The apparatus of claim 20, wherein said raised attaching portion of said base member includes an uppermost surface formed generally in the shape of a square; and

wherein said uppermost surface includes a plurality of corner portions sloping downwardly toward said securing flange.

23. The apparatus of claim 20, wherein said base member is injection molded from a thermoplastic.

24. The apparatus of claim 20, wherein said cover member is injection molded from a thermoplastic.

25. The apparatus of claim 20, wherein each of said locking portions comprises a plurality of integrally formed shoulder portions adapted to releasably engage with a respective one of said flexible latching arms to thereby

enable said cover member to be adjustably positioned in spaced-apart relation to said base member in a first position and a second position.

26. The apparatus of claim 20, wherein said cover member comprises a central portion and an angled peripheral portion; and

wherein said peripheral portion includes a plurality of ventilation slots formed therein for further enhancing airflow outwardly of said opening in said base member to an external environment.

27. The apparatus of claim 20, further comprising a screen securable to said base member, said screen having outer dimensions sufficiently small to fit within an interior area of said cover member when said cover member is secured to said base member so as not to be visible when said cover member is secured to said base member, and yet sufficiently large to completely cover said opening.

28. The apparatus of claim 27, wherein said base member further comprises a cylindrical portion extending from an inner surface of said attaching portion, said cylindrical portion being adapted to engage with a similarly sized section of duct work of said dwelling when said base member is secured to said exterior surface of said dwelling.

29. A vent apparatus comprising:

a base member having a securing flange for securing said base member to an exterior surface of a dwelling;

an attaching portion protruding outwardly from said securing flange, said attaching portion having an opening and a locking portion;

a cover member having a securing member and being of dimensions for enabling said cover member to be positioned at least partially over said attaching portion of said base member;

a screen interposed between said cover member and said base member, said screen having dimensions enabling it to be completely covered by said cover member when said cover member is positioned over said screen; and

said securing member of said cover member being engageable with said locking portion of said base member to secure said cover member to said locking portion such that said cover member is spaced-apart from said attaching portion to allow airflow through said opening and said screen and outwardly between said base member and said cover member.

30. The apparatus of claim 29, wherein said base member includes a cylindrical portion in communication with said central opening for accepting a portion of an external section of duct work.

31. The apparatus of claim 29, wherein said screen comprises:

a generally circular frame-like member and air-permeable screening secured thereto;

said frame-like member having a plurality of locking arm members spaced generally equal distances apart from one another;

said base member including a corresponding plurality of openings for accepting said locking arm members and enabling said screen to be secured to said base member

such that said screen cannot be readily removed from said base member; and

said screen having outer dimensions enabling it to be completely covered by said cover member when said cover member is secured to said base member such that said screen is not visible when said apparatus is secured to said dwelling.

32. The apparatus of claim 29, further comprising:

a cylindrical member fixedly secured to said base member so as to extend outwardly of said base member;

a first length of duct work permanently secured to said cylindrical member;

a second length of duct work removably secured to said first length of duct work;

a third length of duct work removably secured to said second length of duct work; and

said first, second and third lengths of duct work having a total length sufficient to extend through a standard six inch deep wall.

33. The apparatus of claim 32, further comprising an adapter member for enabling said third length of duct work to be coupled to an external length of tubing having a different diameter than said third length of duct work.

* * * * *