



(51) International Patent Classification:

G01F 1/075 (2006.01) *G01D 5/12* (2006.01)
G01F 15/00 (2006.01) *F03B 13/00* (2006.01)

(21) International Application Number:

PCT/US2013/071194

(22) International Filing Date:

21 November 2013 (21.11.2013)

(25) Filing Language:

English

(26) Publication Language:

English

(30) Priority Data:

61/728,844 21 November 2012 (21.11.2012) US

(71) Applicant: **DYNAPAR CORPORATION** [US/US]; 1675 Delaney Road, Gurnee, IL 60031 (US).

(72) Inventors: **COLBY, Edward, Grellier**; 7 Magrath Avenue, Cambridge CB4 3AH (GB). **DAMES, Andrew, Nicholas**; 78 Hartington Grove, Cambridge CB1 7UB (GB). **TAYLOR, Edward, J.**; 32 Froment Way, Milton, Cambridgeshire CB24 6DT (GB). **CLAUSEN, Cathleen Mary**; 7910 Lilly Pond Lane, Wilmington, NC 28411 (US).

(74) Agent: **WOLTER, Robert, L.**; Beusse Wolter Sanks Mora & Maire, P.A., 390 N. Orange Avenue, Suite 2500, Orlando, FL 32801 (US).

(81) Designated States (unless otherwise indicated, for every kind of national protection available): AE, AG, AL, AM, AO, AT, AU, AZ, BA, BB, BG, BH, BN, BR, BW, BY, BZ, CA, CH, CL, CN, CO, CR, CU, CZ, DE, DK, DM, DO, DZ, EC, EE, EG, ES, FI, GB, GD, GE, GH, GM, GT, HN, HR, HU, ID, IL, IN, IR, IS, JP, KE, KG, KN, KP, KR, KZ, LA, LC, LK, LR, LS, LT, LU, LY, MA, MD, ME, MG, MK, MN, MW, MX, MY, MZ, NA, NG, NI, NO, NZ, OM, PA, PE, PG, PH, PL, PT, QA, RO, RS, RU, RW, SA, SC, SD, SE, SG, SK, SL, SM, ST, SV, SY, TH, TJ, TM, TN, TR, TT, TZ, UA, UG, US, UZ, VC, VN, ZA, ZM, ZW.

(84) Designated States (unless otherwise indicated, for every kind of regional protection available): ARIPO (BW, GH, GM, KE, LR, LS, MW, MZ, NA, RW, SD, SL, SZ, TZ, UG, ZM, ZW), Eurasian (AM, AZ, BY, KG, KZ, RU, TJ, TM), European (AL, AT, BE, BG, CH, CY, CZ, DE, DK, EE, ES, FI, FR, GB, GR, HR, HU, IE, IS, IT, LT, LU, LV, MC, MK, MT, NL, NO, PL, PT, RO, RS, SE, SI, SK, SM, TR), OAPI (BF, BJ, CF, CG, CI, CM, GA, GN, GQ, GW, KM, ML, MR, NE, SN, TD, TG).

Published:

- with international search report (Art. 21(3))
- before the expiration of the time limit for amending the claims and to be republished in the event of receipt of amendments (Rule 48.2(h))

(54) Title: SENSOR AND/OR POWER HARVESTING APPARATUS HAVING A WIDE DYNAMIC RANGE FOR RESPONDING TO A DRIVING ROTATIONAL INPUT

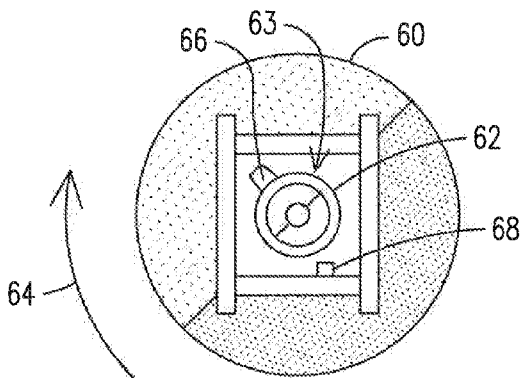

FIG. 7

(57) Abstract: Sensor and/or power-harvesting apparatus are provided for sensing and/or harvesting energy across a relatively wide dynamic range of a driving rotational input. The apparatus may include a rotor magnet (10, 62) responsive to a driving rotational input (14, 64). Utilization of a cogging effect or a magnetic spring effect results in certain rapid-rotation events where the rotor magnet can rapidly rotate regardless of a low rate of rotation of the driving rotational input. A coil assembly (28, 75) is magnetically coupled to the rotor magnet to generate a signal in response to rotation of the rotor magnet during the rapid-rotation events. This signal may be used to harvest electrical energy and/or may be processed to determine characteristics of the driving rotational input.

WO 2014/081919 A1

SENSOR AND/OR POWER HARVESTING APPARATUS HAVING A WIDE
DYNAMIC RANGE FOR RESPONDING TO A DRIVING ROTATIONAL INPUT

CROSS-REFERENCE TO RELATED APPLICATIONS

[01] This application claims the benefit of U.S. Provisional Application No. 61/728,844 filed November 21, 2012, which is incorporated herein by reference in its entirety.

FIELD OF THE INVENTION

[02] The present application is generally related to fluid metering apparatuses, and, more particularly, to apparatus for sensing and/or harvesting energy across a relatively wide dynamic range of a driving rotational input.

BACKGROUND OF THE INVENTION

[03] In industrial applications as well as consumer applications, there frequently arises a need to, for example, measure the quantity and/or flow rate of fluid flow through a conduit; or to measure the rotation of a shaft. For example, conventional water meters operate by measuring the action of the fluid flow on a movable part, such as a nutating disc, paddle wheel or turbine. This creates rotation which may be used to drive a mechanical counter or register, which in turn records and displays an accumulated value of fluid flow consumption over a period of time. This is conventionally read by service personnel who routinely checks each of the meters to manually record the values displayed.

[04] Certain improvements have been made by utilizing flow meter devices involving battery-powered registers. Notwithstanding of design techniques intended to minimize power consumption, the batteries have a limited life time which eventually requires costly and burdensome replacement. Moreover, the performance of such battery-powered registers may be substantially susceptible to ambient temperature variations and may involve hazardous chemicals which require safe disposal at the end of the register's life. Accordingly, at least in view of the foregoing shortcomings, an improved sensor and/or power harvesting apparatus is desirable.

SUMMARY OF THE INVENTION

[05] Generally, aspects of the present invention in one non-limiting embodiment may provide a sensor apparatus comprising a rotor assembly including a rotor magnet responsive to a

driving rotational input. A pole-piece assembly may be magnetically coupled to the rotor magnet and may include a pole-piece configured to effect a respective detent torque in at least two detent locations. As the driving rotational input rotates beyond a threshold angle, the detent torque is overcome, which causes the rotor magnet to angularly accelerate towards the other of the detent locations irrespective of a relatively low rate of rotation of the driving rotational input. A coil assembly is magnetically coupled to the rotor magnet and the pole-piece assembly to generate a signal in response to rotation of the rotor magnet between the two detent locations. A processor is responsive to the signal from the coil assembly to determine at least one characteristic of the rotational input.

[06] Further aspects of the present invention in another non-limiting embodiment may provide a power-harvesting apparatus comprising a rotor assembly including a rotor magnet responsive to a driving rotational input. A pole-piece assembly is magnetically coupled to the rotor magnet and may include a pole-piece configured to effect a respective detent torque in at least two detent locations. As the driving rotational input rotates beyond a threshold angle, the detent torque is overcome and this causes the rotor magnet to angularly accelerate towards the other detent location irrespective of a relatively low rate of rotation of the driving rotational input. A coil assembly is magnetically coupled to the rotor magnet and the pole-piece assembly to generate a signal comprising a stream of pulses in response to rotation of the rotor magnet. At least one circuit component is connected to the coil assembly to receive the stream of pulses generated by the coil assembly and accumulate electrical energy extracted from the received stream of pulses.

[07] Still further aspects of the present invention in yet another non-limiting embodiment may provide apparatus for sensing and power-harvesting comprising a rotor assembly comprising a rotor magnet responsive to a driving rotational input. A pole-piece assembly is magnetically coupled to the rotor magnet and may include a pole-piece configured to effect a respective detent torque in at least two detent locations. As the driving rotational input rotates beyond a threshold angle, the detent torque is overcome, and this causes the rotor magnet to angularly accelerate towards the other detent location irrespective of a relatively low rate of rotation of the driving rotational input. A coil assembly is magnetically coupled to the rotor magnet and the pole-piece assembly to generate a signal comprising a stream of pulses in response to rotation of the rotor magnet. A processor is configured to determine at least one characteristic of the rotational input. A wakeup switching circuit is responsive to the stream of pulses to awake the processor from a power saving condition to determine the characteristic of

the rotational input based on the stream of pulses from the coil assembly. At least one circuit component may be connected to the coil assembly to further receive the stream of pulses generated by the coil assembly and accumulate electrical energy extracted from the received stream of pulses.

[08] In another non-limiting embodiment a sensor apparatus may include a drive magnet arranged to produce a rotating magnetic field in response to a driving rotational input. A rotor assembly includes a rotor magnet responsive to the rotating magnetic field from the drive magnet. The rotor assembly includes a mechanical stop to impede further rotation of the rotor magnet beyond a predefined location of the rotor assembly as the rotating magnetic field continues to rotate. A magnetic spring effect is established between the stopped rotor magnet and the rotating magnetic field, which eventually causes the rotor magnet to angularly accelerate and rotate away from the mechanical stop irrespective of a relatively low rate of rotation of the driving rotational input. A coil assembly is magnetically coupled to the rotor magnet to generate a signal in response to the rotation of the rotor magnet away from the mechanical stop. A processor may be responsive to the signal from the coil assembly to determine data indicative of at least one characteristic of the rotational input.

BRIEF DESCRIPTION OF THE DRAWINGS

[09] Aspects of the invention may be appreciated in view of the drawings that show:

[010] FIGs. 1-3 represent a temporal flow sequence of views for conceptually illustrating an example condition where a rotor magnet, which may be part of a rotor assembly embodying aspects of the present invention, can angularly accelerate in a relatively rapid fashion between at least two detent positions regardless of whether a driving rotational input may comprise a relatively low rate of rotation.

[011] FIG. 4 is a block diagram representation of one example embodiment of a sensor and/or power harvesting apparatus embodying aspects of the present invention.

[012] FIG. 5 primarily shows a pictorial view of one example embodiment of a sensor and/or power harvesting apparatus embodying aspects of the present invention.

[013] FIG. 6 is a schematic of a flow meter register embodying a sensor and/or power harvesting apparatus embodying aspects of the present invention.

[014] FIGs. 7-15 represent a temporal flow sequence of views for conceptually illustrating an example embodiment where a rotor magnet, which may be part of a rotor assembly embodying further aspects of the present invention, can angularly accelerate in a relatively rapid

fashion from a stopped condition in response to a magnetic spring effect regardless of whether a driving rotational input may comprise a relatively low rate of rotation.

[015] FIG. 16 is an isometric view of one example embodiment of a sensor and/or power harvesting apparatus embodying aspects of the present invention, such as may be implemented by utilization of a magnetic spring effect.

DETAILED DESCRIPTION OF THE INVENTION

[016] The present inventors have cleverly recognized certain limitations in connection with known metering devices that may be powered and/or actuated by action of a fluid flow and/or rotation of a shaft. These devices tend to exhibit problematic operation during conditions involving relatively low flow rates. For example, a power converter responsive to the fluid flow may not generate a sufficient level of electrical energy under such low flow rate conditions to either power the metering device and/or trigger a response from the metering device.

[017] In view of such recognition, the present inventors propose innovative sensing apparatus and techniques for achieving accurate and reliable sensing of a driving rotational input (e.g., a rotational stimulus), which may be sensed by a sensor and/or may be utilized by a power-harvesting apparatus embodying aspects of the present invention. Additional aspects of the present invention allow sensing and/or harvesting of energy across a relatively wide dynamic range of the driving rotational input being sensed by the apparatus. In one example embodiment, this may be achieved by an electromotive apparatus adapted to store energy (e.g., magnetic and/or mechanical energy) at certain rotor locations (e.g., detent locations), and further adapted to relatively quickly release such energy and quickly accelerate when released from a given detent location to reach another detent location. In another example embodiment, this may be achieved by an electromotive apparatus adapted to store energy by way of a magnetic spring effect achieved during a stopped rotor condition at a predefined rotor location, and further adapted to relatively quickly release such energy when the magnetic spring effect causes the rotor to rapidly accelerate and flyback (e.g., return) from the stop location.

[018] In either case, an example result is that an apparatus embodying aspects of the present invention can sense the rotational input and/or generate energy even when the driving rotational input comprises a relatively low rate of rotation. For example, there is essentially no reduction in harvesting efficiency even when the driving rotational input may have a rate of rotation practically approaching a zero value.

[019] In the following detailed description, various specific details are set forth in order to provide a thorough understanding of depicted embodiments. However, those skilled in the art will understand that such embodiments may be practiced without these specific details; that the depicted embodiments are non-limiting embodiments; and that alternative embodiments may be implemented. In other instances, methods, procedures, and components, which would be well-understood by one skilled in the art have not been described in detail to avoid unnecessary and burdensome explanation.

[020] Furthermore, various operations may be described as multiple discrete steps performed in a manner that is helpful for understanding the embodiments. However, the order of description should not be construed as to imply that these operations need be performed in the order they are presented, nor that they are even order dependent unless otherwise so described. Moreover, repeated usage of the phrase "in one embodiment" does not necessarily refer to the same embodiment, although it may. Lastly, the terms "comprising", "including", "having", and the like, as used in the present application, are intended to be synonymous unless otherwise so indicated.

[021] In one example embodiment, a sensor and/or power harvesting apparatus embodying aspects of the present invention may include a rotor assembly including a rotor magnet responsive to a driving rotational input, which may be conveyed by way of a drive magnet. In one example embodiment, the driving rotational input may be effected by a fluid flow (e.g., water flow or gas flow in a pipe). In another example embodiment, the driving rotational input may be effected by a rotating structure (e.g., a rotating shaft).

Example Embodiments Based on Cogging

[022] FIGs. 1-3 represent a temporal flow sequence of views for conceptually illustrating an example condition where a rotor magnet 10, which is part of a rotor assembly 12, can angularly accelerate in response to a driving rotational input 14 in a relatively rapid fashion from a first detent location (schematically represented by the views illustrated in FIGs. 1 and 2 respectively showing an upwardly pointing arrow 16 drawn on rotor magnet 10) towards a second detent location (schematically represented by the view illustrated in FIG. 3 showing a downwardly pointing arrow 18 drawn on rotor magnet 10).

[023] Rotor assembly 12 may comprise a pole-piece assembly 20 magnetically coupled to rotor magnet 10. Pole-piece assembly 20 includes a pole-piece 22 configured to effect a respective detent torque (which may also be referred in the art as a "cogging torque") in at least

two detent locations. For example, as a drive magnet 24 rotates in response to rotational input 14 beyond a threshold angle, the value of a magnetic driving torque 25 applied by drive magnet 24 to rotor magnet 10 may be sufficiently high to overcome the detent torque, and this causes rotor magnet 10 to angularly accelerate (snap) in a relatively rapid fashion towards the other detent location regardless of whether the driving rotational input may comprise a relatively low rate of rotation.

[024] In one example embodiment, pole-piece 22 defines an air gap with a profile configured to generate the detent torque at the detent locations. In one example embodiment, the profile of the air gap defined by pole-piece 22 may be arranged to provide at least two stable detent locations (e.g., each comprising a relatively narrow section of a suitable ferromagnetic material, such as iron, to provide corresponding narrow detent locations) for rotor magnet 10. These detent locations may be symmetrically located about the circumference of the rotor (e.g., angularly separated from one another by an angle of 180 degrees).

[025] In one example embodiment, rotor magnet 10 may be symmetrically and diametrically magnetised, as schematically represented by the respective magnetic poles labelled N and S in FIGs. 5 and 6. It is contemplated that rotor magnet 10 could be separate from a coaxial generator magnet (not shown) which may be broadly magnetically coupled to pole-piece assembly 20. It is further contemplated that the detent torque need not be effected by way of magnetic coupling between rotor magnet 10 and pole-piece 22 since such a torque could, in an alternative example embodiment, be generated by way of mechanical coupling between rotor magnet 10 and pole-piece assembly 20 alone or in combination with such magnetic coupling. For example, the detent/release functionality could be implemented by way of a biasing spring mechanism.

[026] It will be appreciated by one skilled in the art that the level of the detent torque decreases relatively fast as rotor magnet 10 snaps away from a given detent location, allowing rotor magnet 10 to rapidly accelerate to the other detent location since rotor magnet 10 may be designed to have a relatively low moment of inertia. It will be appreciated that this rapid angular acceleration between detent locations can advantageously develop irrespective of whether the driving rotational input exhibits a relatively low-rate of rotation.

[027] As may be appreciated in FIGs 5 and 6, a coil assembly 28 is magnetically coupled to rotor magnet 10 and pole-piece assembly 20 to generate a signal in response to rotation of rotor magnet 10 between the detent locations. For example, the magnetic circuit which links rotor magnet 10 to coil assembly 28 may be sufficiently (e.g., relatively tightly)

magnetically coupled to generate the signal in response to rotation of rotor magnet 10. In one example embodiment, coil assembly 28 may generate a pulse when the magnetic flux applied by rotor magnet 10 rapidly reverses its direction as rotor magnet 10 snaps from one detent position to another detent position. This allows harvesting of electrical energy even during conditions where the rotational rate of driving rotational input 14 practically approaches zero. It will be appreciated that the foregoing arrangement of torque storage at the detent locations and subsequent release effectively provides at least some decoupling of the reverse torque (e.g., back EMF) applied to rotor magnet 10 during power generation. Appropriate magnetic shielding may be provided to, for example, avoid interference due to external electromagnetic fields.

[028] As shown in FIG. 4, the signal generated by the cooperative interaction of rotor assembly 12 and coil assembly 28 may comprise a stream of pulses 39. A processor 40, such as micro-processor, application specific integrated circuit (ASIC), etc., may be responsive to the signal from coil assembly 28 to determine at least one characteristic of the rotational input. In the example embodiment, where the driving rotational input may be effected by a fluid flow, the characteristic determined by processor 40 may be one or more of the following: a flow rate of the fluid flow, flow direction, quantity of flow over a period of time. In the example embodiment, where the driving rotational input may be effected by a rotating structure, the characteristic determined by processor 40 may be one or more of the following: a rotation rate of the structure, a direction of rotation of the structure, number of rotations over a period of time.

[029] In one example embodiment, a non-volatile memory 42 may be used to store data indicative of the one or more characteristics of the rotational input determined by processor 40. In one example embodiment, one or more circuit components 44 (designated as electrical energy storage) may be connected to accumulate electrical energy from the stream of pulses generated by coil assembly 28 regardless of whether the driving rotational input may comprise a relatively low rate of rotation. For example, the stream of pulses may be rectified by a rectifier and a rectified electrical output may be used to charge one or more storage capacitors.

[030] In one example embodiment, a wake-up switch circuit 46 may be responsive to the stream of pulses from coil assembly 28 to wake-up processor 40 from a power-conserving mode. Data stored in non-volatile memory 42 may be read by an external local device or by a remote device over a communications link (not shown). A display 48 may be optionally provided to display information regarding the rotational input. Display 48 may be arranged to operate just under power conditions when sufficient power is available. For example, such as when sufficient power is available to meet sensing requirements as well as display requirements.

[031] In one example application, an apparatus embodying pole-piece assembly 20 and coil assembly 28 may be utilized to energize and generate sensing information for a fluid meter register 50 (FIG. 6), such a water meter register, gas meter register etc.

Example Embodiments Based on Magnetic Spring Effect

[032] The description below focuses on embodiments based on utilization of a magnetic spring effect. It will be appreciated by those skilled in the art that previously described aspects -- other than the modality or principle for causing the rapid angular acceleration of the rotor irrespective of whether the driving rotational input exhibits a relatively low-rate of rotation-- remain equally applicable for this embodiment. Accordingly, aspects, such as signal processing, power harvesting, example applications, etc., will not be described again for the sake of avoiding burdensome and unnecessary repetition.

[033] FIGs. 7-15 represent a temporal flow sequence of views for conceptually illustrating an example embodiment where a rotor magnet 62, which may be part of a rotor assembly 63 embodying further aspects of the present invention, can angularly accelerate in a relatively rapid fashion from a stopped condition due to a magnetic spring effect regardless of whether a driving rotational input may comprise a relatively low rate of rotation.

[034] FIGs. 7-11 illustrate rotation of rotor magnet 62 in response to a rotating magnetic field 64, such as may be produced by a drive magnet 60 in response to a driving rotational input, such as a fluid flow, a rotating structure, etc. In one example embodiment, rotor magnet 62 may include a feature 66 (e.g., a protrusion, recess, etc.) that upon continued rotation of rotor magnet 62 eventually reaches and interferes with a suitable mechanical stop 68 (FIG. 11) that may be constructed at a predefined location of rotor assembly 63.

[035] At this stage of the flow sequence, rotor magnet 62 remains stopped whilst the axial orientation of rotating magnetic field 64 may impose a magnetic force on rotor magnet 62 in a direction that circumferentially pushes rotor magnet 62 against stop 68. FIGs. 12-14 illustrate continued rotation of magnetic field 64 whilst rotor magnet 62 remains in a stopped condition. As magnetic field 64 continues to rotate, its axial orientation eventually transitions to a condition at which --in lieu of imposing a magnetic force on rotor magnet 62 in a direction that circumferentially pushes rotor magnet 62 against stop 68-- magnetic field 64 will start to develop a magnetic force on rotor magnet 62 in a direction circumferentially opposite from stop 68.

[036] It will be appreciated that at this stage of the flow sequence, a magnetic spring effect is being established between the stopped rotor magnet and the rotating magnetic field. A

gradual winding-up condition of the magnetic spring effect is conceptually represented by the gradually increasing arc segments 70 illustrated in FIGs 12-14. Eventually, the circumferentially pulling force (FIG. 15) substantially and rapidly increases in magnitude and causes rotor magnet 62 to rapidly rotate away, as indicated by arrow 71, (this rapid return rotation may be referred to as a flyback event for the rotor) from mechanical stop 68 until the magnetic field of rotor magnet 62 re-acquires the rotating magnetic field 64 and the temporal flow sequence resumes at FIG. 7. The rapid unwinding action of the magnetic spring effect (e.g., rapid energy release) is conceptually represented by arc segment 72 in FIG. 15.

[037] It will be appreciated that during the flyback event, a relatively high amount of electrical power can be harvested through a coil assembly 75 (FIG. 16) because of the rapid angular velocity of the rotor. Coil assembly 75 is magnetically coupled to rotor magnet 62 and will generate a signal in response to the rapid rotation of the rotor magnet away from the mechanical stop. The rate of flyback rotation can be relatively high compared to the driving rotational input, regardless of the rate of rotation of the driving rotational input. Thus, energy can be extracted even for driving rotational inputs that may approach practically a zero rate of rotation.

[038] FIG. 16 is an isometric view of one example embodiment of a sensor and/or power harvesting apparatus 74 embodying aspects of the present invention, such as may be implemented by utilization of the above-discussed magnetic spring effect. The coil assembly may be arranged to encompass the rotor (e.g., a co-axial arrangement), in which case there is no need for a pole assembly to provide a magnetic circuit to direct the flux of the rotor to the coil. Alternatively, in a non-coaxial arrangement, a basic pole assembly may be readily arranged to couple the flux from the rotor to the coil assembly.

[039] It will be appreciated by those skilled in the art that in one example implementation, the rotor shape may be designed to have the lowest rotational inertia that can be achieved for a given magnetic dipole. This would allow the rotor to achieve the highest angular velocity during the flyback event, thereby practically maximizing the amount of energy that can be harvested by the coil assembly. In practice, this would suggest that relatively tall and thin rotor shapes may be relatively more efficient than disk-shaped rotors. Tradeoff considerations may be considered so that the angular velocity during the flyback event is not so excessively high to avoid the possibility that the magnetic field of rotor magnet 62 overshoots the rotating magnetic field 64 since this could lead to undesirable transients, such as may involve transient rotor oscillation.

[040] The stop may be arranged to function both for clockwise and counterclockwise directions of rotation of the driving field. Thus, a sensing apparatus may be responsive to a driving rotational input, regardless of its direction of rotation. Tradeoffs may be considered regarding the relative positioning of the coil assembly and the circumferential location of the stop. For example, such relative positioning may be arranged to provide a symmetric response to clockwise and counterclockwise rotation so as to maximize the amount of power that can be extracted, but may lack rotation direction information. Thus, in certain applications, an asymmetric response may be used to provide the ability to distinguish clockwise and counterclockwise rotation. As suggested above, such an asymmetric response may not provide a maximal power harvesting capability.

[041] While various embodiments of the present invention have been shown and described herein, it will be apparent that such embodiments are provided by way of example only. Numerous variations, changes and substitutions may be made without departing from the invention herein. Accordingly, it is intended that the invention be limited only by the spirit and scope of the appended claims.

CLAIMS

The invention claimed is:

1. A sensor apparatus comprising:
 - a rotor assembly comprising a rotor magnet responsive to a driving rotational input;
 - a pole-piece assembly magnetically coupled to the rotor magnet and having a pole-piece configured to effect a respective detent torque in at least two detent locations, wherein, as the driving rotational input rotates beyond a threshold angle said detent torque is overcome, which causes the rotor magnet to angularly accelerate towards the other one of said at least two detent locations irrespective of a relatively low rate of rotation of the driving rotational input;
 - a coil assembly magnetically coupled to the rotor magnet and the pole-piece assembly to generate a signal in response to rotation of the rotor magnet between said at least two detent locations; and
 - a processor responsive to the signal from the coil assembly to determine data indicative of at least one characteristic of the rotational input.
2. The sensor apparatus of claim 1, wherein the driving rotational input is effected by a fluid flow and said at least one characteristic of the rotational input comprises one or more of the following: a flow rate of the fluid flow, a quantity of flow over a period of time and a direction of the flow.
3. The sensor apparatus of claim 1, wherein the driving rotational input is effected by a rotating structure and said at least one characteristic of the rotational input comprises one or more of the following: a rotation rate of the structure, a number of rotations over a period of time and a direction of rotation of the structure.
4. The sensor apparatus of claim 1, further comprising a drive magnet to magnetically convey the driving rotational input to the rotor magnet.
5. The sensor apparatus of claim 1, wherein the signal generated by the coil assembly comprises a stream of pulses.
6. The sensor apparatus of claim 1, further comprising a non-volatile memory to store the data from the processor.

7. The sensor apparatus of claim 5, further comprising at least one circuit component arranged to accumulate electrical energy from the stream of pulses generated by the coil assembly.

8. The sensor apparatus of claim 1, wherein the respective detent torque is effected in said at least two detent locations by way of magnetic coupling.

9. The sensor apparatus of claim 1, wherein the respective detent torque is effected in said at least two detent locations by way of mechanical coupling.

10. The sensor apparatus of claim 1, wherein the respective detent torque is effected in said at least two detent locations by way of magnetic coupling and/or mechanical coupling.

11. A flow meter register comprising the sensor apparatus of claim 1.

12. A power-harvesting apparatus comprising:
a rotor assembly comprising a rotor magnet responsive to a driving rotational input;
a pole-piece assembly magnetically coupled to the rotor magnet and having a pole-piece configured to effect a respective detent torque in at least two detent locations, wherein, as the driving rotational input rotates beyond a threshold angle said detent torque is overcome, which causes the rotor magnet to angularly accelerate towards the other one of said at least two detent locations irrespective of a relatively low rate of rotation of the driving rotational input;
a coil assembly magnetically coupled to the rotor magnet and the pole-piece assembly to generate a signal comprising a stream of pulses in response to rotation of the rotor magnet; and
at least one circuit component connected to the coil assembly to receive the stream of pulses generated by the coil assembly and accumulate electrical energy extracted from the received stream of pulses.

13. The power-harvesting apparatus of claim 12, wherein the driving rotational input is effected by a fluid flow.

14. The power-harvesting apparatus of claim 12, wherein the driving rotational input is effected by a rotating structure.

15. The power-harvesting apparatus of claim 12, further comprising a drive magnet to magnetically convey the driving rotational input to the rotor magnet.

16. The power-harvesting apparatus of claim 12, wherein the respective detent torque is effected in said at least two detent locations by way of magnetic coupling.

17. The power-harvesting apparatus of claim 12, wherein the respective detent torque is effected in said at least two detent locations by way of mechanical coupling.

18. The power-harvesting apparatus of claim 12, wherein the respective detent torque is effected in said at least two detent locations by way of magnetic coupling and/or mechanical coupling.

19. A flow meter register comprising the power-harvesting apparatus of claim 12.

20. Apparatus for sensing and power-harvesting comprising:
a rotor assembly comprising a rotor magnet responsive to a driving rotational input;
a pole-piece assembly magnetically coupled to the rotor magnet and having a pole-piece configured to effect a respective detent torque in at least two detent locations, wherein, as the driving rotational input rotates beyond a threshold angle said detent torque is overcome, which causes the rotor magnet to angularly accelerate towards the other one of said at least two detent locations irrespective of a relatively low rate of rotation of the driving rotational input;
a coil assembly magnetically coupled to the rotor magnet and the pole-piece assembly to generate a signal comprising a stream of pulses in response to rotation of the rotor magnet;
a processor to determine data indicative of at least one characteristic of the rotational input;
a wakeup switching circuit responsive to the stream of pulses to awake the processor from a power saving condition to determine said at least one characteristic of the rotational input based on the stream of pulses from the coil assembly; and

at least one circuit component connected to the coil assembly to further receive the stream of pulses generated by the coil assembly and accumulate electrical energy extracted from the received stream of pulses.

21. A sensor apparatus comprising:

a drive magnet arranged to produce a rotating magnetic field in response to a driving rotational input;

a rotor assembly comprising a rotor magnet responsive to the rotating magnetic field from the drive magnet, wherein the rotor assembly includes a mechanical stop to impede further rotation of the rotor magnet beyond a predefined location of the rotor assembly as the rotating magnetic field continues to rotate, wherein a magnetic spring effect is established between the stopped rotor magnet and the rotating magnetic field, which eventually causes the rotor magnet to angularly accelerate and rotate away from the mechanical stop irrespective of a relatively low rate of rotation of the driving rotational input;

a coil assembly magnetically coupled to the rotor magnet to generate a signal in response to the rotation of the rotor magnet away from the mechanical stop; and

a processor responsive to the signal from the coil assembly to determine data indicative of at least one characteristic of the rotational input.

22. The sensor apparatus of claim 21, wherein the driving rotational input is effected by a fluid flow and said at least one characteristic of the rotational input comprises one or more of the following: a flow rate of the fluid flow, a quantity of flow over a period of time and a direction of the flow.

23. The sensor apparatus of claim 21, wherein the driving rotational input is effected by a rotating structure and said at least one characteristic of the rotational input comprises one or more of the following: a rotation rate of the structure, a number of rotations over a period of time and a direction of rotation of the structure.

24. The sensor apparatus of claim 21, wherein the signal generated by the coil assembly comprises a stream of pulses.

25. The sensor apparatus of claim 21, further comprising a non-volatile memory to store the data from the processor.

26. The sensor apparatus of claim 24, further comprising at least one circuit component connected to the coil assembly to receive the stream of pulses generated by the coil assembly and accumulate electrical energy extracted from the received stream of pulses

27. A flow meter register comprising the sensor apparatus of claim 21.

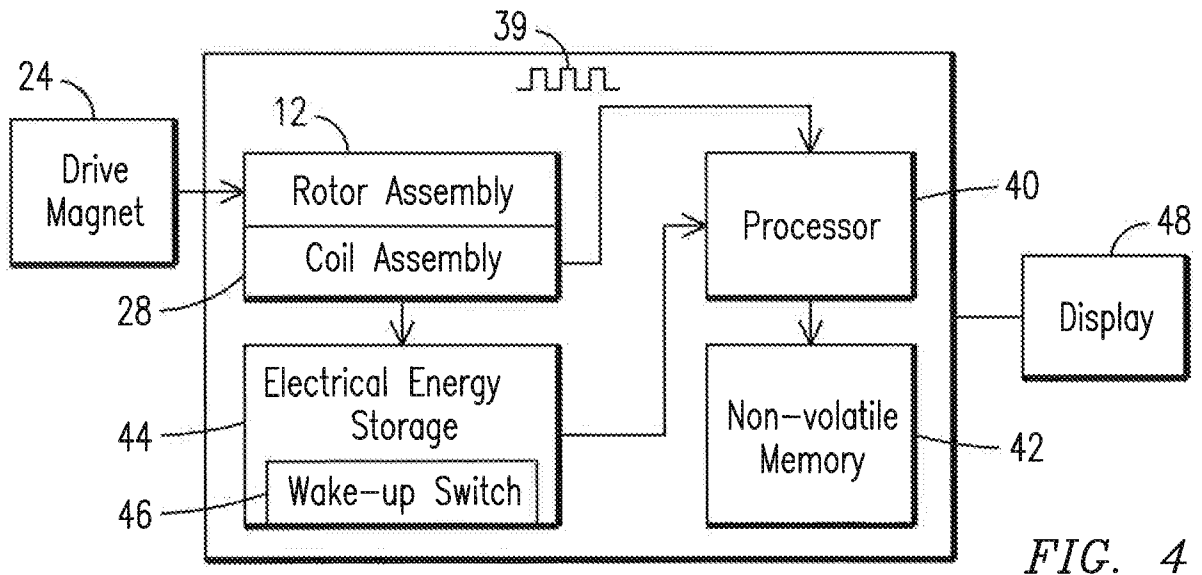
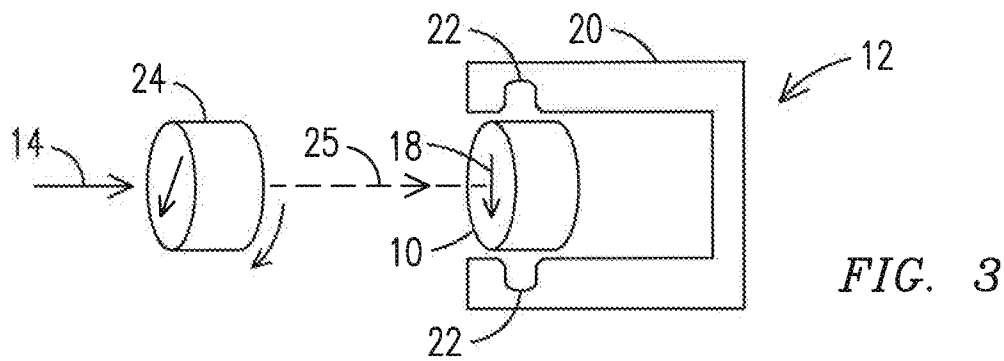
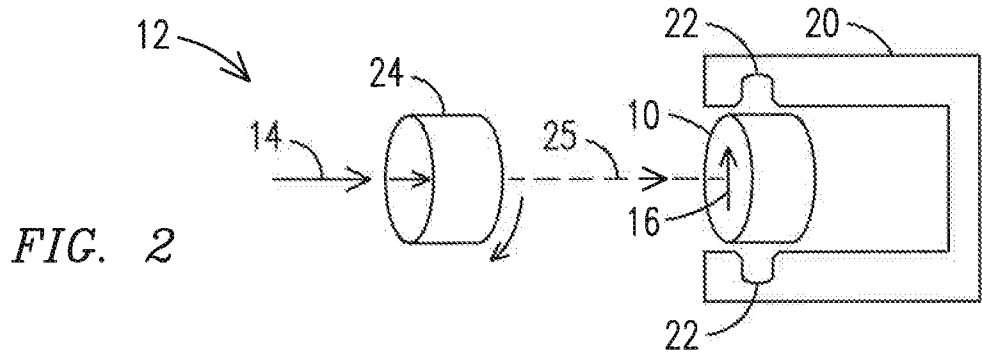
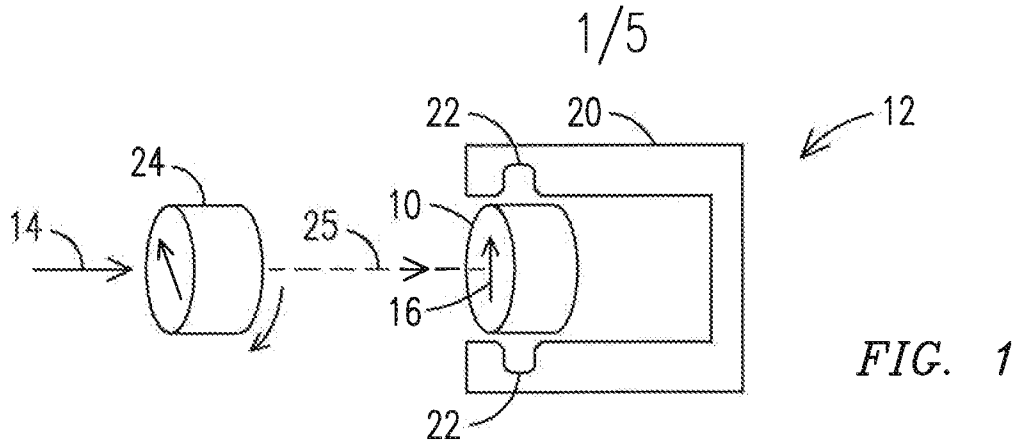

2/5

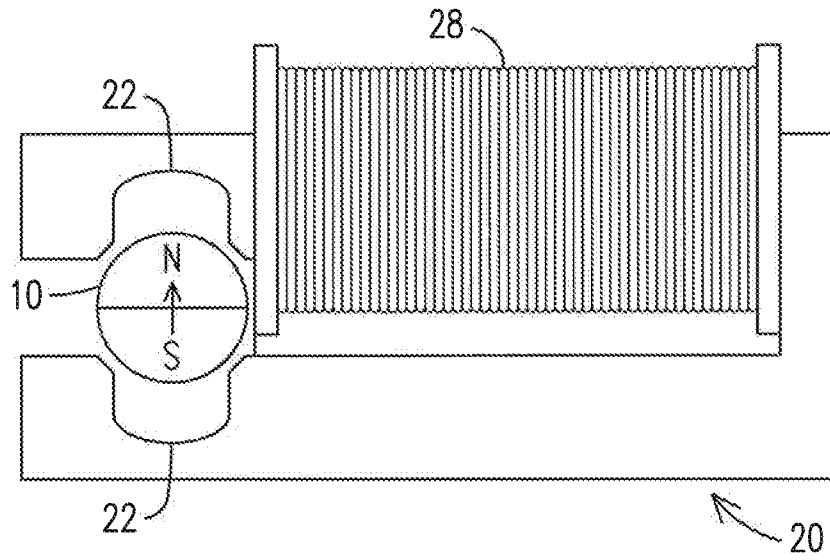

FIG. 5

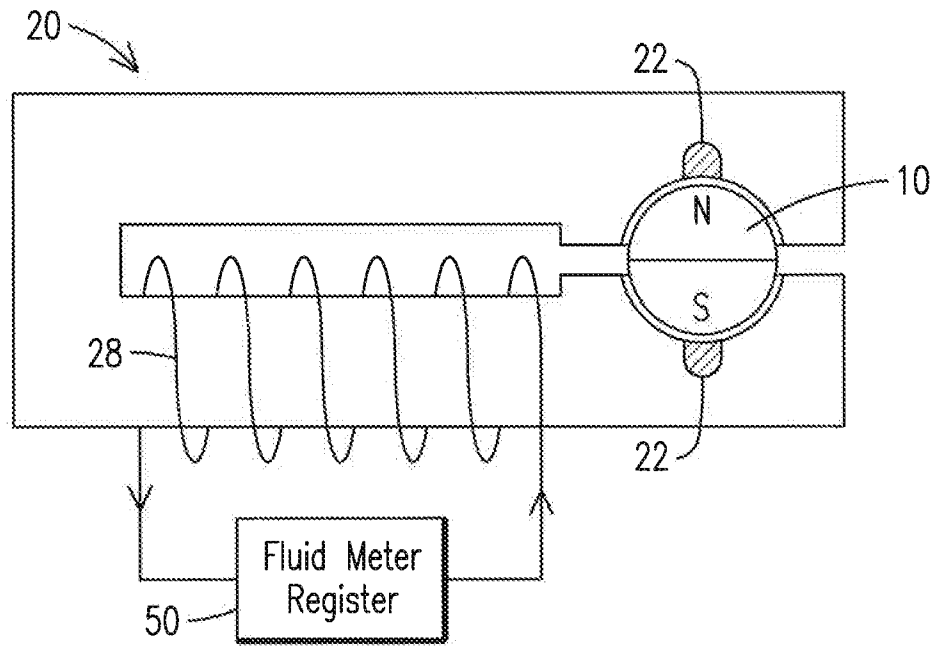

FIG. 6

3/5

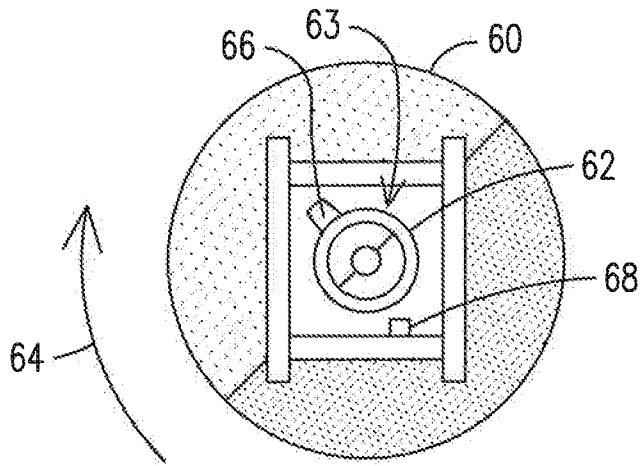

FIG. 7

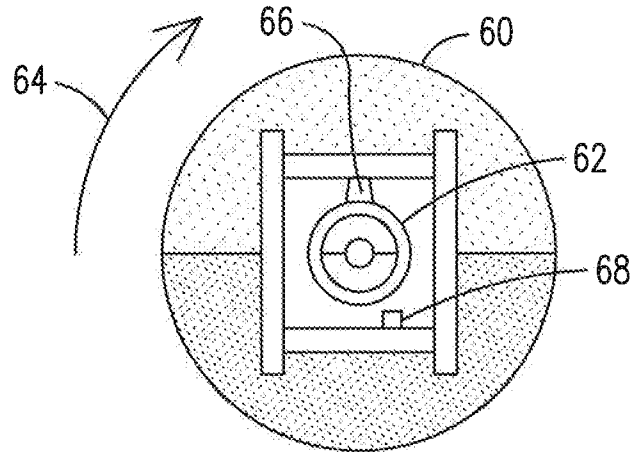

FIG. 8

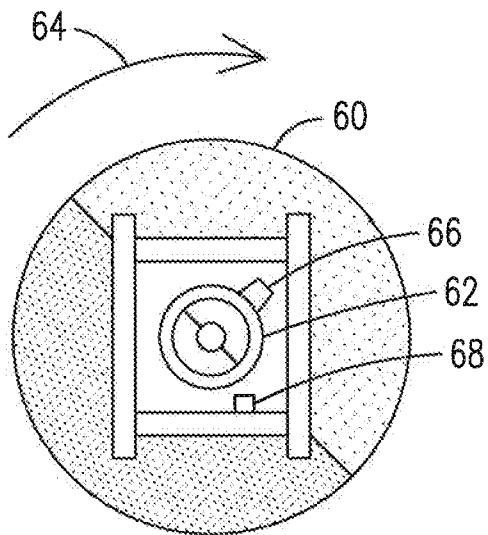

FIG. 9

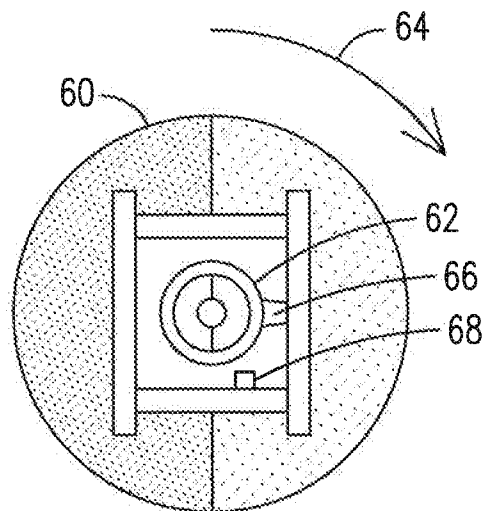

FIG. 10

4/5

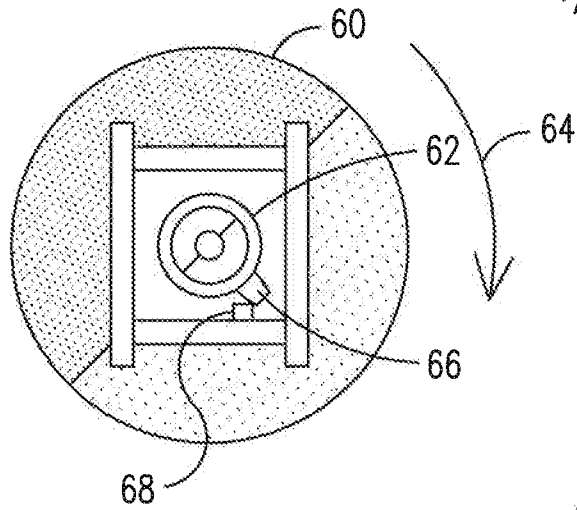

FIG. 11

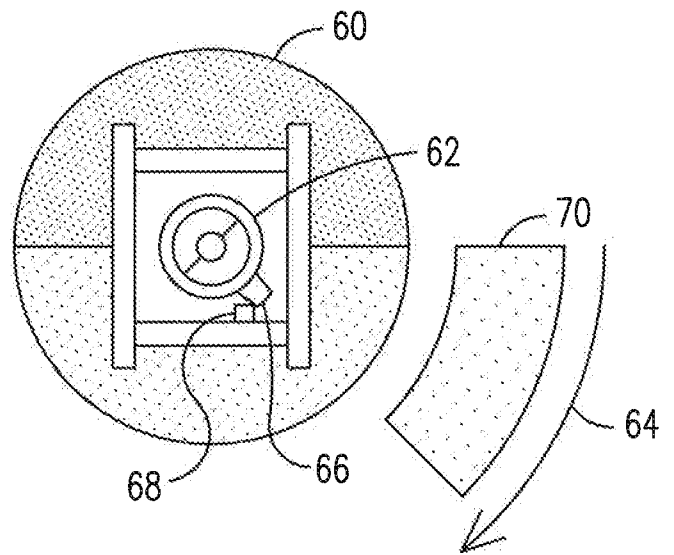

FIG. 12

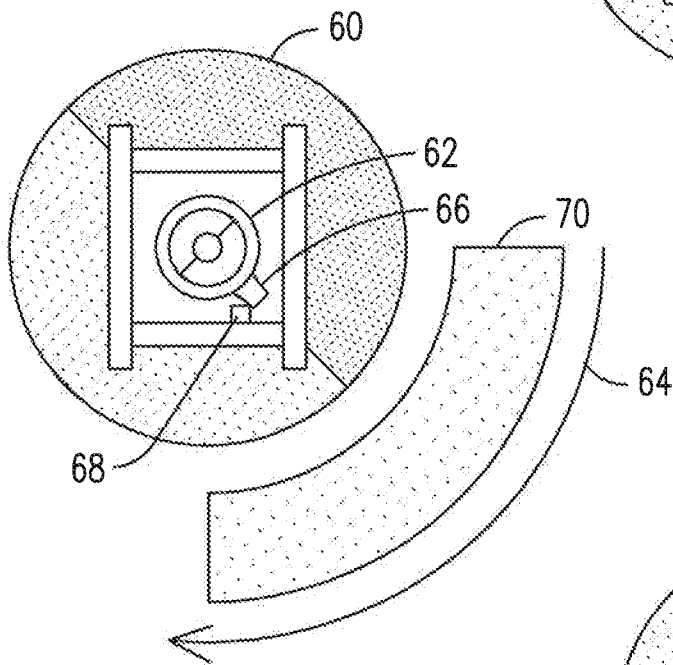

FIG. 13

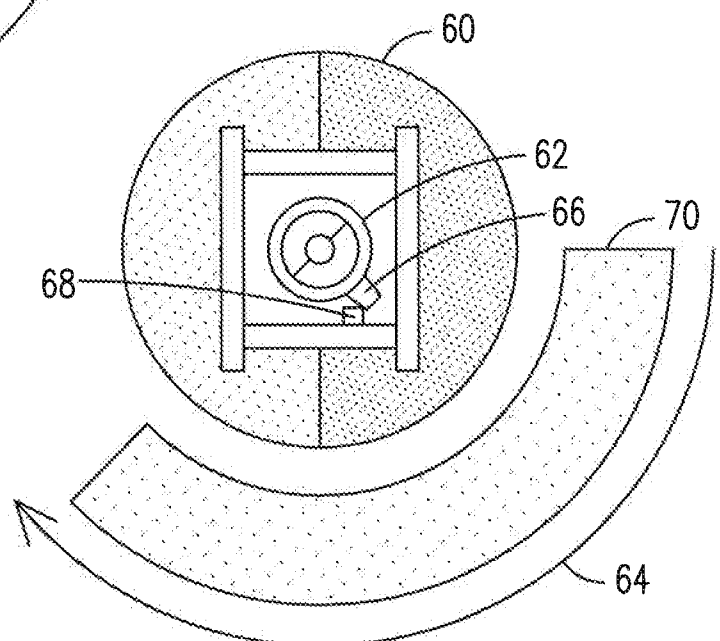

FIG. 14

5/5

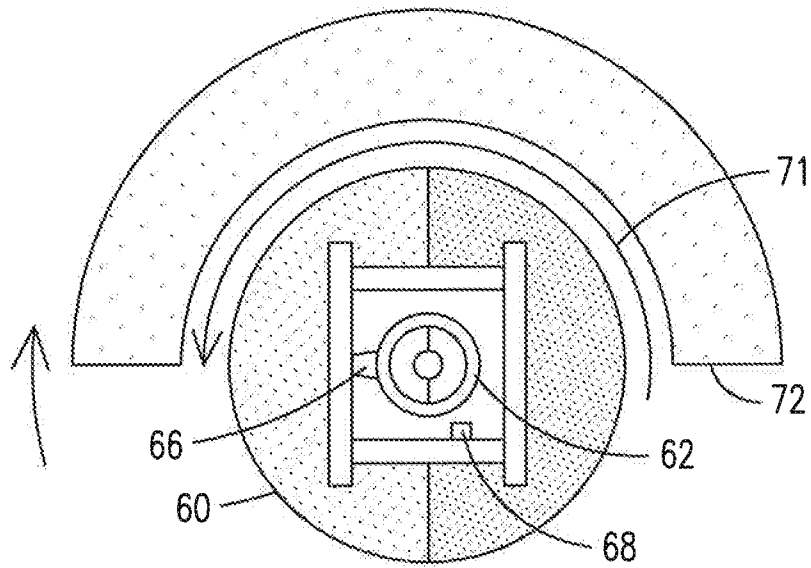

FIG. 15

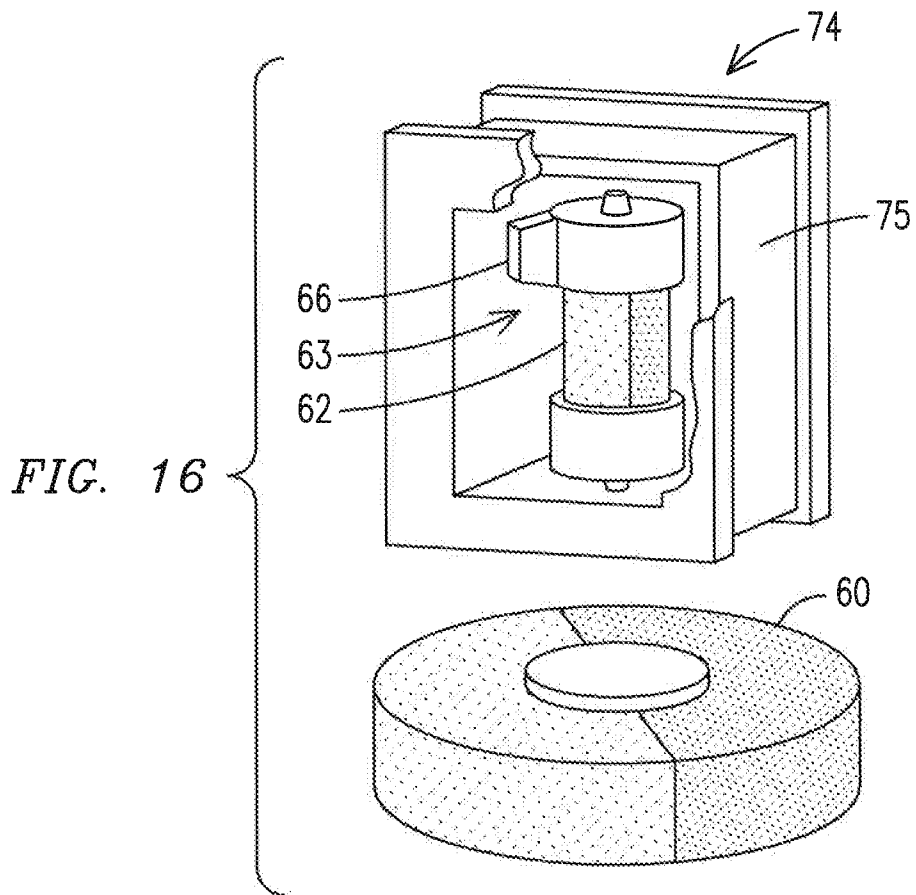

FIG. 16

A. CLASSIFICATION OF SUBJECT MATTER**G01F 1/075(2006.01)i, G01F 15/00(2006.01)i, G01D 5/12(2006.01)i, F03B 13/00(2006.01)i**

According to International Patent Classification (IPC) or to both national classification and IPC

B. FIELDS SEARCHED

Minimum documentation searched (classification system followed by classification symbols)

G01F 1/075; F03B 13/08; B60K 1/00; G04B 19/06; H02K 7/10; G01R 1/20; G01F 15/00; G01D 5/12; F03B 13/00

Documentation searched other than minimum documentation to the extent that such documents are included in the fields searched

Korean utility models and applications for utility models

Japanese utility models and applications for utility models

Electronic data base consulted during the international search (name of data base and, where practicable, search terms used)

eKOMPASS(KIPO internal) & keywords: rotate, rotor, magnet, impede, pole-piece, coil, detent and torque

C. DOCUMENTS CONSIDERED TO BE RELEVANT

Category*	Citation of document, with indication, where appropriate, of the relevant passages	Relevant to claim No.
A	EP 0182652 A2 (NIPPONDENSO CO., LTD.) 28 May 1986 See abstract; pages 4-6; claims 1-8 and figures 1-6.	1-27
A	US 5424632 A (MONTAGU, JEAN) 13 June 1995 See abstract; column 5, line 50 - column 7, line 51 and figures 1-16.	1-27
A	US 2012-0169054 A1 (ROOS, PAUL W.) 05 July 2012 See abstract; paragraphs 149-156 and figures 1-8D.	1-27
A	US 2005-0110353 A1 (KRAMER, DENNIS A.) 26 May 2005 See abstract; paragraphs 16-31 and figures 1-5.	1-27
A	US 5878004 A (MIYAUCHI et al.) 02 March 1999 See abstract; column 28, lines 50-61; claim 1 and figures 1-11, 38A-38D.	1-27

 Further documents are listed in the continuation of Box C. See patent family annex.

* Special categories of cited documents:

"A" document defining the general state of the art which is not considered to be of particular relevance

"E" earlier application or patent but published on or after the international filing date

"L" document which may throw doubts on priority claim(s) or which is cited to establish the publication date of another citation or other special reason (as specified)

"O" document referring to an oral disclosure, use, exhibition or other means

"P" document published prior to the international filing date but later than the priority date claimed

"T" later document published after the international filing date or priority date and not in conflict with the application but cited to understand the principle or theory underlying the invention

"X" document of particular relevance; the claimed invention cannot be considered novel or cannot be considered to involve an inventive step when the document is taken alone

"Y" document of particular relevance; the claimed invention cannot be considered to involve an inventive step when the document is combined with one or more other such documents, such combination being obvious to a person skilled in the art

"&" document member of the same patent family

Date of the actual completion of the international search

19 March 2014 (19.03.2014)

Date of mailing of the international search report

20 March 2014 (20.03.2014)

Name and mailing address of the ISA/KR

International Application Division
Korean Intellectual Property Office
189 Cheongsu-ro, Seo-gu, Daejeon Metropolitan City, 302-701,
Republic of Korea

Facsimile No. +82-42-472-7140

Authorized officer

AHN, Jae Yul

Telephone No. +82-42-481-8525



INTERNATIONAL SEARCH REPORT

Information on patent family members

International application No.

PCT/US2013/071194

Patent document cited in search report	Publication date	Patent family member(s)	Publication date
EP 0182652 A2	28/05/1986	DE 3582917 D1	27/06/1991
		EP 0182652 A3	05/08/1987
		EP 0182652 B1	22/05/1991
		JP 06012948 B2	16/02/1994
		JP 1890374 C	07/12/1994
		JP 61-124255 A	12/06/1986
		US 4691135 A	01/09/1987
US 5424632 A	13/06/1995	JP 03199813 B2	20/08/2001
		JP 06-094751 A	08/04/1994
		US 5225770 A	06/07/1993
US 2012-0169054 A1	05/07/2012	WO 2013-112573 A2	01/08/2013
US 2005-0110353 A1	26/05/2005	EP 1536544 A2	01/06/2005
		EP 1536544 A3	25/04/2007
		US 2006-0267425 A1	30/11/2006
US 5878004 A	02/03/1999	EP 0585470 A1	09/03/1994
		EP 0585470 B1	10/09/1997
		JP 03258125 B2	18/02/2002
		JP 03432470 B2	04/08/2003
		JP 06235777 A	23/08/1994
		JP 2000-139098 A	16/05/2000
		US 6349075 B1	19/02/2002
		WO 93-19404 A1	30/09/1993