



US00D993291S

(12) **United States Design Patent**  
**Fukuda**

(10) **Patent No.:** **US D993,291 S**

(45) **Date of Patent:** **\*\* Jul. 25, 2023**

(54) **CUTTING TOOL**

(71) Applicant: **SUMITOMO ELECTRIC  
HARDMETAL CORP., Itami (JP)**

(72) Inventor: **Hirochika Fukuda, Itami (JP)**

(73) Assignee: **SUMITOMO ELECTRIC  
HARDMETAL CORP., Itami (JP)**

(\*\*) Term: **15 Years**

(21) Appl. No.: **29/850,612**

(22) Filed: **Aug. 22, 2022**

**Related U.S. Application Data**

(62) Division of application No. 29/767,413, filed on Jan. 22, 2021, now Pat. No. Des. 975,760.

(30) **Foreign Application Priority Data**

Jul. 28, 2020 (JP) ..... 2020-015601 D  
Jul. 28, 2020 (JP) ..... 2020-015602 D

(51) **LOC (14) Cl.** ..... **15-09**

(52) **U.S. Cl.**  
USPC ..... **D15/139**

(58) **Field of Classification Search**  
USPC ..... D8/20, 70; D15/126, 131, 138, 139, 140  
CPC ..... B23B 27/145; B23B 27/1622; B23B  
2200/048; B23B 2200/204; B23B  
2200/085; B23B 2200/0423; B23C 5/205;  
B23C 5/207; B23C 2200/125; B23C  
2200/0416; B23C 2200/0477; B23C  
2200/0494

See application file for complete search history.

(56) **References Cited**

**U.S. PATENT DOCUMENTS**

D584,752 S 1/2009 Jonsson et al.  
D637,214 S 5/2011 Saito et al.

D688,716 S 8/2013 Lampe  
D700,639 S 3/2014 Choi et al.  
D718,357 S 11/2014 Park  
D804,552 S 12/2017 Lee et al.  
D805,564 S 12/2017 Lee et al.  
D805,566 S 12/2017 Oh et al.  
D807,935 S 1/2018 Dudzinsky et al.  
D847,883 S 5/2019 Kobayashi  
D898,085 S 10/2020 Kim et al.

(Continued)

*Primary Examiner* — Patricia A Palasik

(74) *Attorney, Agent, or Firm* — Faegre Drinker Biddle & Reath LLP

(57) **CLAIM**

The ornamental design for a cutting tool, as shown and described.

**DESCRIPTION**

FIG. 1 is a front view of a cutting tool of an embodiment showing my new design;  
FIG. 2 is a rear view thereof;  
FIG. 3 is a right side view thereof;  
FIG. 4 is a left side view thereof;  
FIG. 5 is a top view thereof;  
FIG. 6 is a bottom view thereof;  
FIG. 7 is a first perspective view thereof;  
FIG. 8 is a second perspective view thereof;  
FIG. 9 is an enlarged view of portion 9 of FIG. 5;  
FIG. 10 is a cross sectional view taken along line 10-10 of FIG. 9;  
FIG. 11 is a cross sectional view taken along line 11-11 of FIG. 9;  
FIG. 12 is a cross sectional view taken along line 12-12 of FIG. 9; and,  
FIG. 13 is a referential view showing the state in use thereof.  
The broken lines shown in views represent portions that form no part of the claimed design.

**1 Claim, 7 Drawing Sheets**

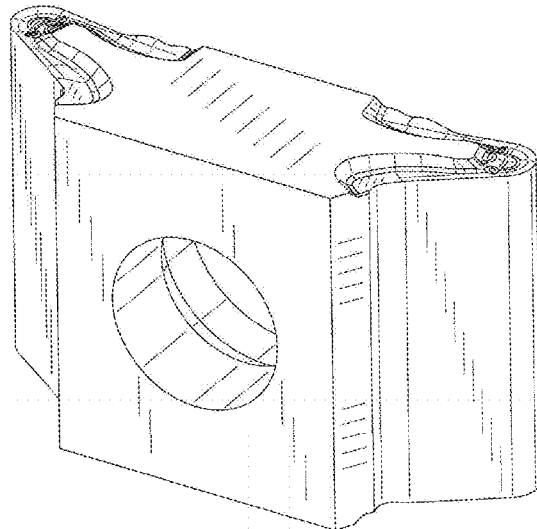

(56)

**References Cited**

U.S. PATENT DOCUMENTS

D927,573 S	8/2021	Kim et al.	
D936,713 S	11/2021	Endoh et al.	
D975,760 S *	1/2023	Fukuda .....	B25C 5/06 D15/139

\* cited by examiner

FIG. 1

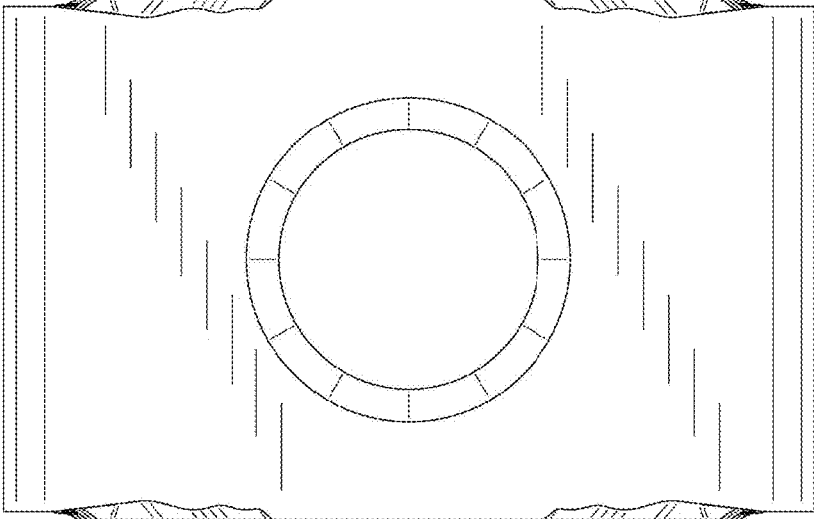

FIG. 2

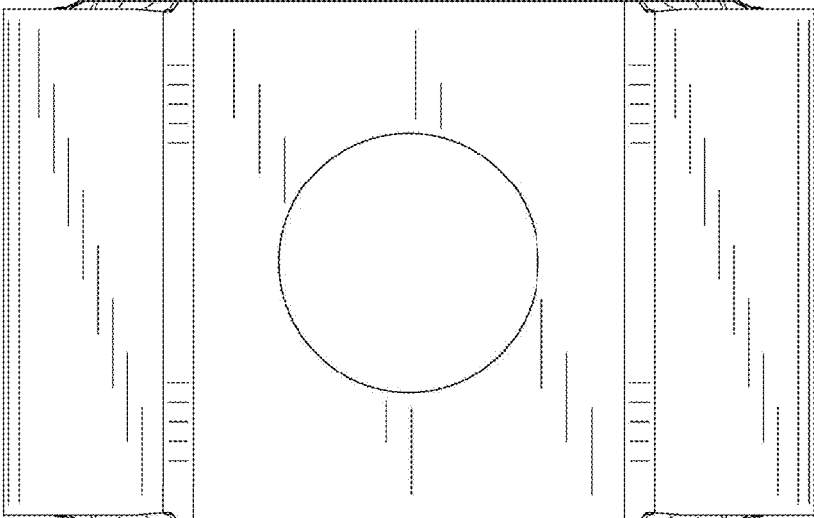

FIG. 3

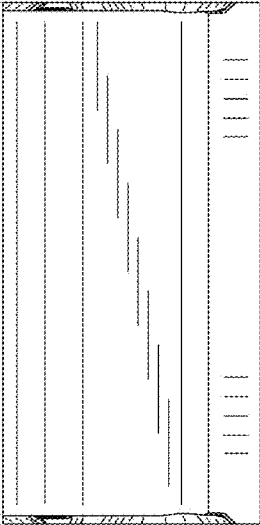

FIG. 4

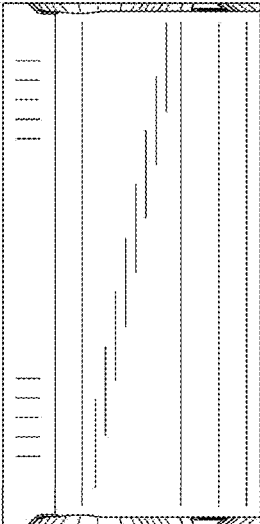

FIG. 5

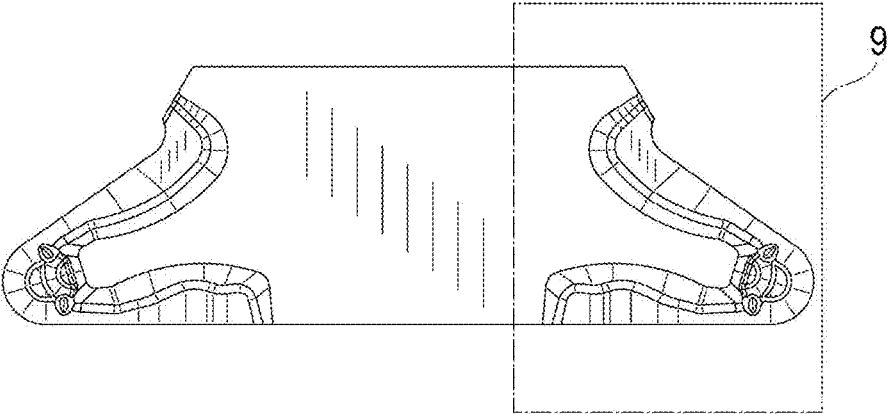

FIG. 6

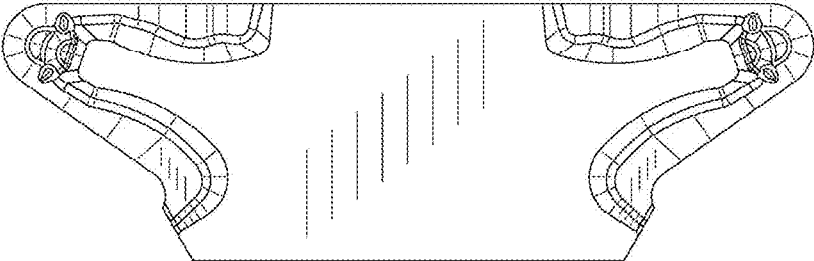

FIG. 7

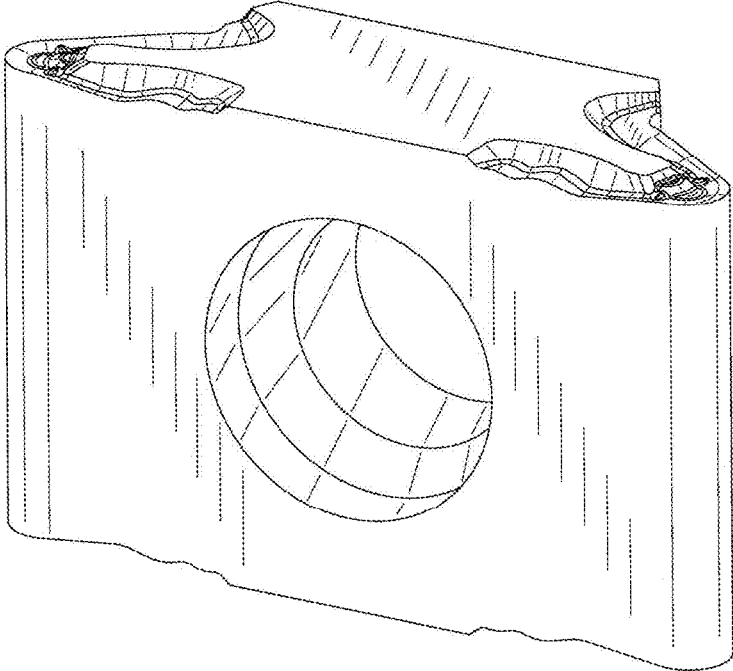

FIG. 8

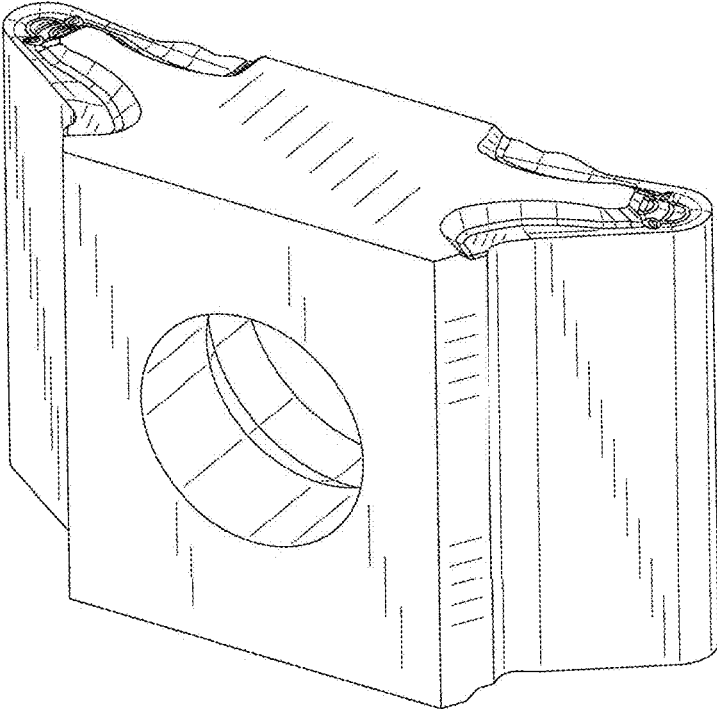

FIG. 9

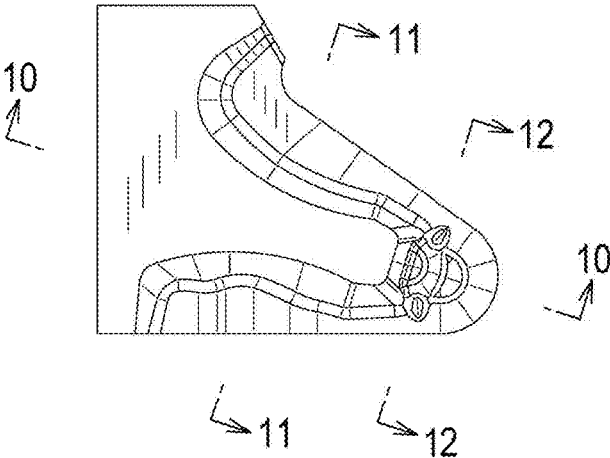

FIG.10

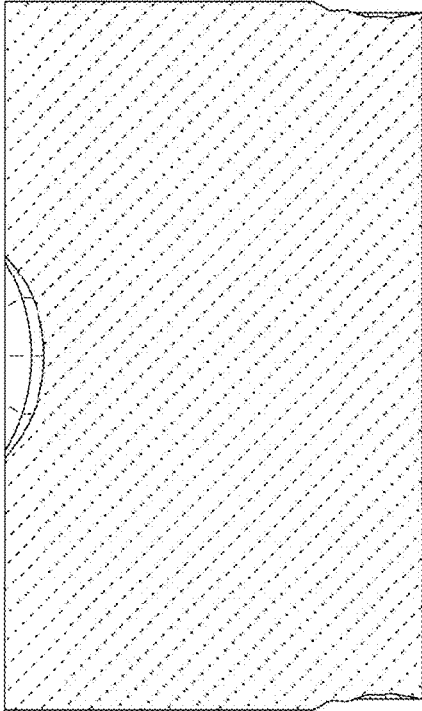

FIG. 11

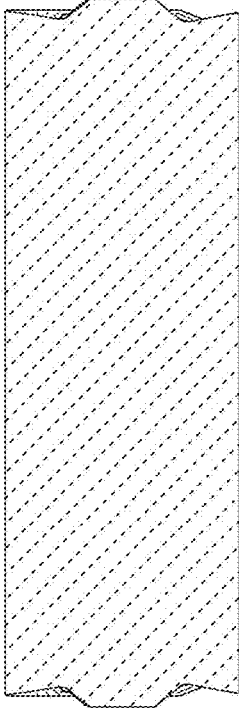

FIG. 12

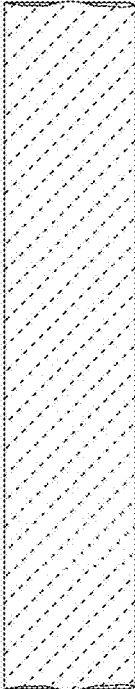



FIG. 13

