

Jan. 13, 1970

H. A. STAMMEN

3,489,249

INDUSTRIAL LIFT TRUCK

Filed Dec. 22, 1967

2 Sheets-Sheet 1

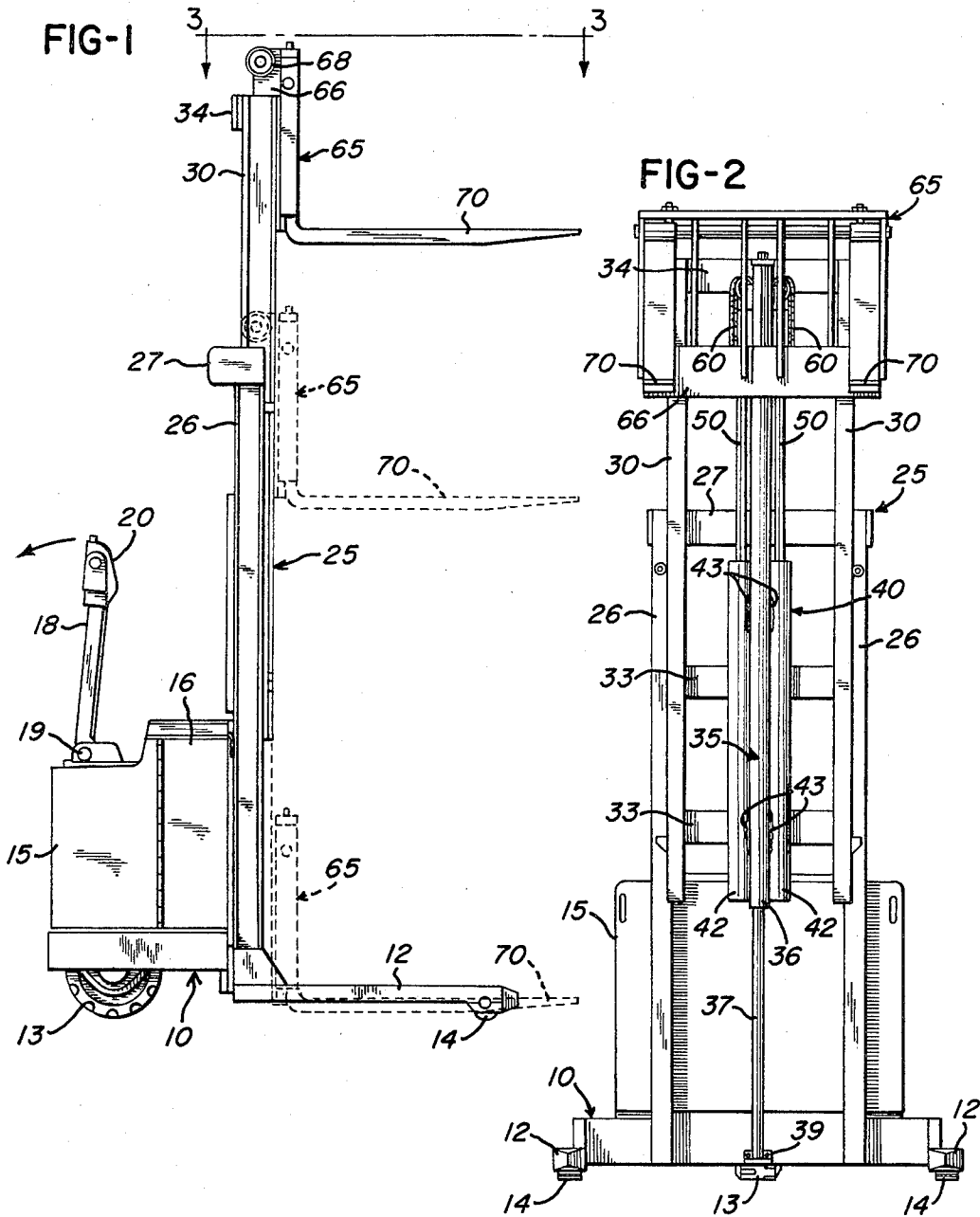

INVENTOR
HAROLD A. STAMMEN

BY
Marschal, Biebel, French & Bugg
ATTORNEYS

Jan. 13, 1970

H. A. STAMMEN

3,489,249

INDUSTRIAL LIFT TRUCK

Filed Dec. 22, 1967

2 Sheets-Sheet 2

FIG-3

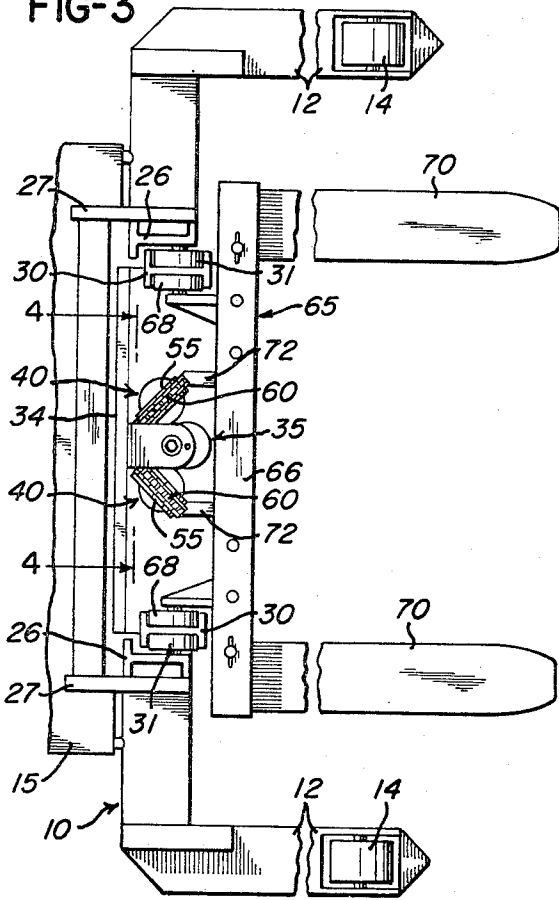

FIG-4

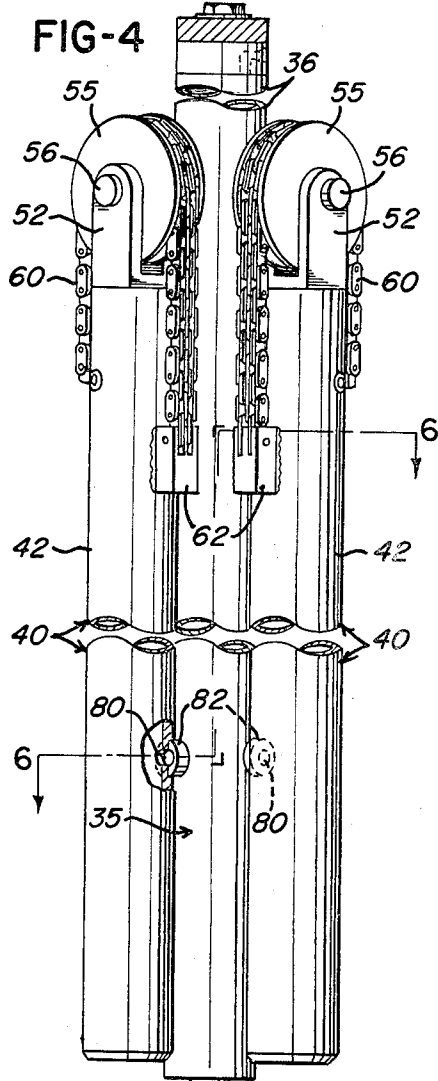

FIG-5

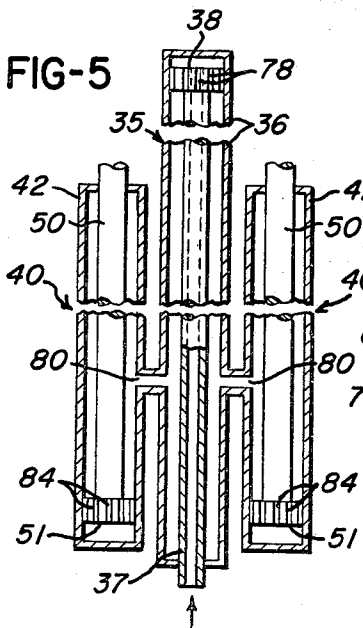
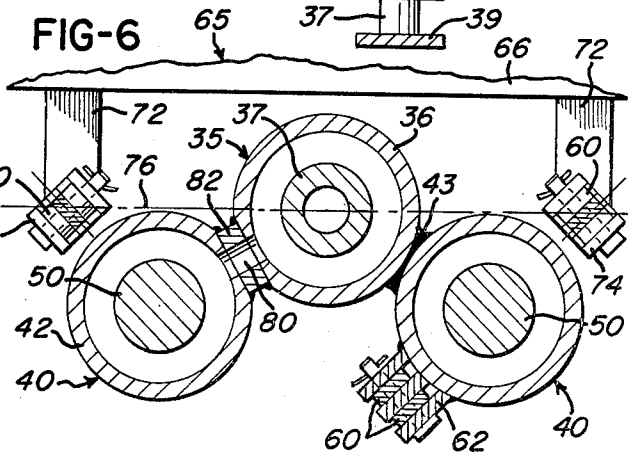

FIG-6



1

3,489,249

INDUSTRIAL LIFT TRUCK

Harold A. Stammen, New Bremen, Ohio, assignor to Crown Controls Corporation, New Bremen, Ohio, a corporation of Ohio

Filed Dec. 22, 1967, Ser. No. 692,885

Int. Cl. B66b 9/20

U.S. Cl. 187-9

3 Claims

ABSTRACT OF THE DISCLOSURE

A lift truck has a wheel supported frame and an upright telescopic mast including stationary mast members and movable mast members supporting a fork lift carriage, and three rigidly connected hydraulic cylinders are supported in closely spaced triangular relationship on the movable mast members, with the ram of the center cylinder connected to the frame and the rams of the two side cylinders supporting angularly disposed rollers over which endless lift chains are directed; one end of each lift chain is connected to the corresponding cylinder and the opposite ends of the chains are connected to the fork carriage within a plane extending through the axis of the center cylinder.

Background of the invention

Some forms of industrial fork lift trucks use three parallel hydraulic cylinders to produce the desired lifting force for raising the fork carriage and extending the telescopic mast supporting the carriage. The cylinders are commonly arranged in coplanar aligned relationship with the ram of the center cylinder connected to the truck frame and the ram of the two side cylinders supporting rollers over which a pair of endless lift chains are directed.

On some lift trucks, the rollers and corresponding chains are arranged in parallel spaced relation on opposite sides of the center cylinder with the forward ends of the chains connected to the carriage forward of the plane of the cylinders. This construction results in some off-center loading on the ram of the center cylinder thereby producing bending movements on the ram when it is extended. In other lift trucks, the rollers and corresponding chains are aligned in the plane of the cylinders. While this construction overcomes the off-center loading on the ram of the center cylinder, substantial lateral spacing is required between the cylinders to provide clearance for the chains. This spacing requires additional hydraulic lines and substantially reduces the forward visibility of the truck operator, who must frequently look between the cylinders and chains to see where the truck is headed or to determine the elevation of the lift forks. Moreover, with either construction, the aligned coplanar arrangement of the laterally spaced cylinders requires a substantial percentage of the space within the telescopic masts thereby obstructing the view of the operator.

Summary of the invention

The present invention is directed to an improved arrangement and construction of three hydraulic cylinders for an industrial fork lift truck, which not only eliminates off-center loading of the ram of the center cylinder but also substantially increases the forward visibility for the truck operator. In accordance with a preferred embodiment of the invention, the above features are provided by arranging the three hydraulic cylinders in a triangular cluster with the spacing between the two side cylinders being less than the outside diameter of the center cylinder. The ram of the center cylinder is connected at its bottom to the truck frame and the rams of the side cylinders support pulleys or rollers which are positioned in angular

2

relation so that the rearward ends of the lift chains directed over the rollers are positioned in close spaced relation while the forward ends of the chains connect to the fork carriage in a plane which extends through the centerline of the center hydraulic cylinder.

Other features and advantages of the invention will be apparent from the following description, the accompanying drawings and the appended claims.

Brief description of the drawings

FIG. 1 is an elevational view of a lift truck incorporating a cylinder construction and arrangement in accordance with the invention;

FIG. 2 is a front elevational view of the lift truck shown in FIG. 1;

FIG. 3 is a fragmentary plan view of the lift truck taken generally on the line 3-3 of FIG. 1;

FIG. 4 is an enlarged elevational view of the hydraulic cylinders and lift chains taken generally on the line 4-4 of FIG. 3 and with the center portion of the cylinders broken away;

FIG. 5 is a schematic section of the cylinders showing their interconnecting fluid flow path; and

FIG. 6 is an enlarged section taken generally along the line 6-6 of FIG. 4 and showing a portion of the lift carriage.

Description of the preferred embodiment

Referring to the drawings, the lift truck shown in FIGS. 1-3 includes a frame 10 having forwardly extending and parallel spaced outrigger members 12, and supported by a single rear wheel 13 and a pair of smaller wheels 14 mounted on the forward ends of the members 12. In a suitable manner, the single rear wheel 13 may be driven by a reversible electrical motor (not shown) enclosed within a housing 15 and operated by rechargeable batteries (not shown) which are stored behind a hinged access door 16. The drive wheel 13 is steerable by a handle 18 which is pivotable on a support shaft 19 and carries the various control switches within a control housing 20. This general form of truck is shown merely as being typical, it being understood that the invention is applicable to other types.

A vertical telescopic mast 26 includes a pair of outer mast members 26 having lower portions rigidly connected to the frame 10 and upper portions rigidly connected by a cross member 27. The telescopic mast 25 also includes a pair of parallel spaced inner mast members 30 which are supported and guided by a series of vertically spaced rollers 31 (FIG. 3) mounted on the inner and outer mast members. The lower portions of the inner mast members 30 are rigidly connected by a pair of cross members 33 (FIG. 2), and the upper ends are rigidly connected by a similar cross member 34.

A hydraulic cylinder 35 extends vertically midway between the inner mast members 30 and includes a cylindrical housing 36 having its upper end rigidly connected to the cross member 34. The housing 36 supports a tubular ram 37 having a slightly enlarged upper head 38 (FIG. 5) and its lower end portion rigidly connected to the frame 10 by a bracket 39. A pair of hydraulic side cylinders 40 include cylindrical housings 42 each rigidly connected to the center cylinder 35 by vertically spaced welds 43 (FIGS. 2 and 6). As best shown in FIG. 6, the center cylinder 35 and side cylinders 40 are arranged in a closely spaced triangular cluster with the lateral spacing between the housings 42 of the two side cylinders 40 being less than the outside diameter of the housing 36 of the center cylinder 35.

Each of the side cylinders 40 has a ram 50 (FIGS. 2, 5 and 6) with a slightly enlarged lower head 51 (FIG. 5) and an upper end supporting a U-shaped bracket 52. A

3

roller 55 is mounted on each bracket 52 by a shaft 56, and a pair of leaf-type lift chains 60 are directed over the rollers 55. As shown in FIGS. 3 and 4, the rollers 55 and corresponding chains 60 are arranged at approximately right angles with the rearward ends of the chains 60 (FIG. 4) connected to anchor blocks 62 each welded to the upper portion of the corresponding side cylinder 40.

The forward ends of the lift chains 60 are connected to a fork lift carriage 65 having a frame 66 supported by rollers 68 (FIG. 3) guided by the inner mast members 30. The carriage 65 includes a pair of forwardly projecting pallet engaging forks 70 and a pair of rearwardly projecting brackets 72 (FIG. 6) on which are mounted anchor blocks 74 for receiving the forward ends of the lift chains 60. Referring to FIG. 6, the anchor blocks 74 are located within a plane 76 which extends through the axis of the ram 37 of the center lift cylinder 35. Thus the balanced lifting forces exerted by the chains 60 on the carriage 65 when the rams 50 are extended, are in alignment with the center cylinder 35 so that no bending moments are exerted on the center cylinder ram 37 when it is extended.

Referring to FIGS. 4-6, hydraulic fluid is supplied to the cluster of cylinders 35 and 40 from a suitable gear pump (not shown) through the lower end of the ram 37. The hydraulic fluid flows within passageways 78 formed within the head 38 of the ram 37 and downwardly to passageways 80 formed within the walls of the cylinder housings 36 and 42 and also within connecting collars 82 (FIG. 6) welded between aligned spot faces on the housing 42 of each side cylinder 40 and the housing 36 of the center cylinder 35. Passageways 84 are formed in the lower heads 51 of the side cylinder rams 50 to enable the hydraulic fluid to flow into the cylinder space below the rams.

In operation, when hydraulic fluid is introduced through the bottom of the ram 37 of the center cylinder 35, the rams 50 of the side cylinders extend upwardly to raise the carriage 65 on the collapsed inner mast members 30. While the combined effective force area of the rams 50 is approximately twice the effective force area of the ram 37, this is offset by the 2:1 mechanical advantage provided by the chains 60. However, the rams 50 extend before the ram 37 since the ram 37 supports the weight of the connected cylinder housings 36 and 42, rams 50 and inner mast 30. After the rams 50 of the side cylinders 40 are fully extended and the carriage is moved to its highest position relative to the inner mast members 30, the carriage 65 is elevated higher by continuing the supply of fluid to the ram 37 thereby elevating the center cylinder 35 which carries with it the inner mast members 30 and also the side cylinders 40 due to the rigid connection of the cylinder housings provided by the welds 43.

From the drawings and the above description, it becomes apparent that a lift truck having a triangular cluster cylinder arrangement in accordance with the invention provides desirable features and advantages. That is, by connecting the forward ends of the lift chains 60 to the brackets 72 of the fork carriage 65 at points which are aligned with the axis of the center cylinder 35, there is no off-center forces acting on the ram 37 tending to bend the ram when a load is supported by the carriage 65. As can be seen in FIG. 2, the triangular cluster of cylinders 35 and 40 also provides a compact arrangement so that

4

there is substantial open space between the side cylinders 40 and the inner masts 30. As a result, the operator has good forward visibility and can easily determine the precise elevation and position of the lift forks 70.

Another important feature is provided by the connection between the center cylinder 35 and the side cylinders 40 by the vertically spaced welds 43 and the annular collars 82 which cooperate to define high pressure passageways interconnecting the housing of the center cylinder 35 and the side cylinders 40. That is, this connection of the cylinders provides for a simplified and economical construction and assures that the passageways 80 are positively sealed for withstanding substantially high hydraulic pressure.

While the form of apparatus herein described constitutes a preferred embodiment of the invention, it is to be understood that the invention is not limited to this precise form of apparatus, and that changes may be made therein without departing from the scope of the invention.

What is claimed is:

1. In a hydraulic lift truck including a frame, substantially vertical outer mast members mounted on said frame, movable inner mast members supported by said outer mast members, and a load support carriage mounted for vertical movement on said inner mast members, an improved lift mechanism for said carriage, comprising a cluster of three hydraulic cylinders arranged in closely spaced triangular relation with one center cylinder positioned generally between two side cylinders, a ram for each said cylinder, means rigidly connecting said cylinders, means connecting said cylinders to said inner mast members, means connecting said ram of said center cylinder to said frame, a roller mounted on said ram of each said side cylinder, a pair of elongated flexible lift members each having one end connected to said cylinders and extending over said rollers, said rollers having axes extending substantially perpendicular to each other, and means located in a plane extending substantially through the axis of said ram of said center cylinder for connecting each said lift member to said carriage for eliminating off-center loads on said ram of said center cylinder.

2. A hydraulic lift truck as defined in claim 1 including a plurality of axially spaced weld means connecting each said side cylinder to said center cylinder, and means defining a passageway within at least one of said weld means.

3. A hydraulic lift truck as defined in claim 1 wherein said center cylinder is positioned forwardly of said side cylinders, and said carriage includes a pair of rearwardly projecting bracket members spaced on opposite sides of said center cylinder for connecting said flexible lift members to said carriage.

References Cited

UNITED STATES PATENTS

2,399,632	5/1946	Guerin	187-9
2,634,587	4/1953	Ptak	187-9
2,788,863	4/1957	Ulinski	187-9
2,804,174	8/1957	Chasar	187-9
2,821,264	1/1958	Ulinski	187-9
2,991,847	7/1961	Ulinski	187-9

HARVEY C. HORNSBY, Primary Examiner