



US00D963811S

(12) **United States Design Patent**
Angelozzi et al.

(10) **Patent No.:** **US D963,811 S**

(45) **Date of Patent:** **** Sep. 13, 2022**

(54) **TAMPER EVIDENT OVERCAP FOR DRUM CLOSURES**

(71) Applicant: **Rieke Corporation**, Auburn, IN (US)

(72) Inventors: **Anthony Angelozzi**, Fort Wayne, IN (US); **Dale W. Taylor**, Hamilton, IN (US)

(73) Assignee: **RIEKE LLC**, Auburn, IN (US)

(**) Term: **15 Years**

(21) Appl. No.: **29/692,648**

(22) Filed: **May 28, 2019**

(51) **LOC (13) Cl.** **23-01**

(52) **U.S. Cl.**

USPC **D23/260**; D9/438

(58) **Field of Classification Search**

USPC D23/259–260, 261; D9/434–435,
D9/438–439; 220/257.2; 215/232, 254,
215/256, 307

CPC B65D 51/18; B65D 47/12
See application file for complete search history.

(56) **References Cited**

U.S. PATENT DOCUMENTS

1,996,674	A	4/1935	Cross
1,996,682	A	4/1935	O'Brien
3,838,785	A	10/1974	Lancesseur
3,858,742	A	1/1975	Grussen
3,865,268	A	2/1975	Coop
3,931,904	A	1/1976	Coop

(Continued)

FOREIGN PATENT DOCUMENTS

CN	103043296	4/2013
CN	103363110	10/2013

(Continued)

OTHER PUBLICATIONS

Rieke PT-4 Cap Seal; Rieke website downloaded Spec Sheet PDF; <https://www.riekepackaging.com/pdf-generator/cache/APT-4.pdf>; Visited Online Jul. 13, 2021; Printed Jul. 2021 (Year: 2021).*

(Continued)

Primary Examiner — Amy C Wierenga

(74) *Attorney, Agent, or Firm* — McDonald Hopkins LLC

(57) **CLAIM**

The ornamental design for a tamper-evident overcap for drum closures, as shown and described.

DESCRIPTION

FIG. 1 is a perspective view of the top facing of the tamper-evident overcap for drum closures according to a first embodiment;

FIG. 2 is a perspective view of the bottom facing shown in FIG. 1;

FIG. 3 is a top plan view shown in FIG. 1;

FIG. 4 is a cross sectional side view shown in FIG. 1 taken along line 4-4;

FIG. 5 is a front plan view, including the protruding structure visible in FIGS. 1-3, shown in FIG. 1;

FIG. 6 is a rear plan view shown in FIG. 1; and,

FIG. 7 is a bottom plan view shown in FIG. 1.

FIG. 8 is a perspective view of the top facing of the tamper-evident overcap for drum closures according to a second embodiment;

FIG. 9 is a perspective view of the bottom facing shown in FIG. 8;

FIG. 10 is a top plan view shown in FIG. 8;

FIG. 11 is a cross sectional side view shown in FIG. 8 taken along line 11-11;

FIG. 12 is a front plan view, including the protruding structure visible in FIGS. 8-10, shown in FIG. 8;

FIG. 13 is a rear plan view shown in FIG. 8; and,

FIG. 14 is a bottom plan view shown in FIG. 8.

1 Claim, 6 Drawing Sheets

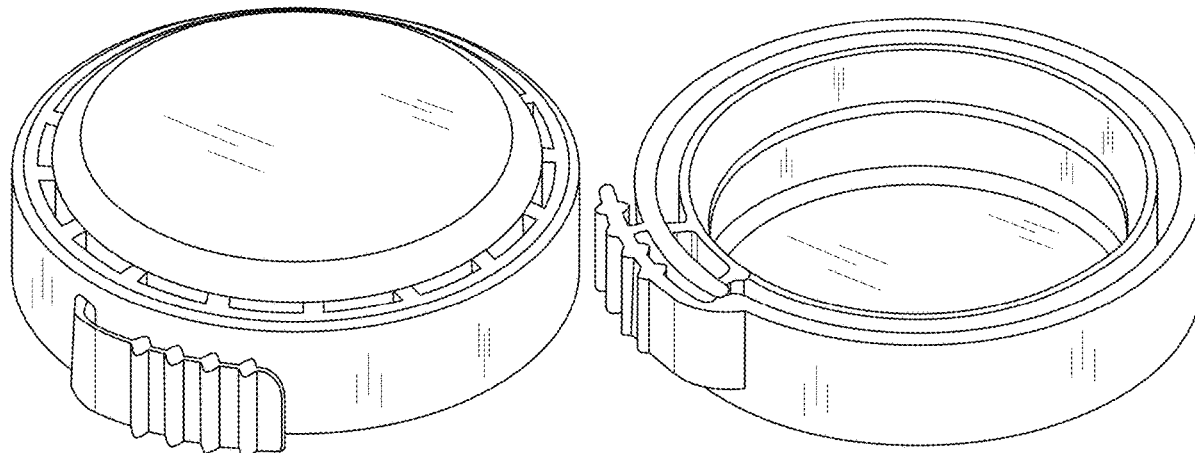

(56)

References Cited

U.S. PATENT DOCUMENTS

4,073,399 A 2/1978 Lewis
 D248,376 S * 7/1978 Allen D9/443
 4,227,619 A 10/1980 Magnusson
 4,230,229 A 10/1980 Crisci
 4,387,818 A 6/1983 Conti
 4,493,432 A * 1/1985 Smith B65D 43/0256
 220/270
 4,520,942 A 6/1985 Dwinell
 4,534,481 A 8/1985 Summers
 4,574,974 A * 3/1986 von Holdt B65D 1/46
 220/782
 4,718,571 A * 1/1988 Bordner B65D 43/0258
 220/270
 4,785,963 A 11/1988 Magley
 4,796,769 A * 1/1989 Obadia B65D 47/12
 215/232
 4,801,032 A * 1/1989 Crisci B65D 41/46
 215/256
 4,881,656 A * 11/1989 Chumley B26F 1/22
 220/270
 D312,044 S * 11/1990 Davis D9/438
 5,002,198 A * 3/1991 Smith B65D 43/0262
 220/276
 5,065,883 A * 11/1991 Udell B65D 55/0863
 220/276
 5,080,246 A 1/1992 Hayes
 5,224,616 A * 7/1993 Crisci B65D 41/485
 215/256
 5,292,019 A * 3/1994 Patterson B65D 41/3404
 215/254
 D381,906 S * 8/1997 Bartsch D9/438
 5,884,788 A 3/1999 Wilde
 5,971,183 A * 10/1999 Bartsch B65D 43/0256
 215/256
 5,996,833 A 12/1999 Lencioni
 6,116,444 A 9/2000 Boesl
 6,360,908 B1 3/2002 Kline
 D462,269 S * 9/2002 Hunter D9/435
 6,726,048 B2 4/2004 Dwinell
 6,968,968 B2 11/2005 Buckley
 7,080,749 B2 7/2006 Van Bruggen

D547,652 S * 7/2007 Kerman D9/438
 7,537,132 B2 5/2009 Marple
 7,568,585 B2 8/2009 Baughman
 7,731,048 B2 * 6/2010 Teixeira Alvares
 B65D 21/0219
 220/270
 8,777,030 B2 7/2014 Ziegenhorn
 8,813,988 B2 * 8/2014 Ledemeny B65D 55/0863
 220/257.2
 9,005,240 B2 4/2015 Joensson
 9,371,161 B2 6/2016 Rudy
 9,434,518 B2 * 9/2016 Ledemeny B65D 41/58
 9,546,027 B2 1/2017 Ziegenhorn
 D782,771 S 3/2017 Morris
 D800,276 S * 10/2017 Taylor D23/260
 10,059,490 B2 8/2018 Schuetz
 10,086,985 B2 10/2018 Klatt
 10,150,599 B2 12/2018 Julien
 10,183,791 B2 1/2019 Friedrich
 10,703,547 B2 * 7/2020 Filho B65D 51/18
 2003/0168456 A1 9/2003 Tomasella
 2004/0232100 A1 11/2004 Reidenbach
 2014/0061250 A1 3/2014 Turcotte
 2017/0121064 A1 5/2017 Taylor

FOREIGN PATENT DOCUMENTS

DE	10201422235	12/2015
DE	102016124071	4/2018
EP	0725013	8/1996
EP	1642843	4/2006
GB	1386369	3/1975
GB	2222399	3/1990
WO	WO1994026615	11/1994
WO	WO1994029186	12/1994
WO	WO2005056411	6/2005

OTHER PUBLICATIONS

Tri-Sure, For Metal Containers Metal Tab-Seal Caps, Tri-Sure Product Brochure, 2015.
 Tri-Sure, For Metal Containers Sambacap Caps, Tri-Sure Product Brochure, 2015.

* cited by examiner

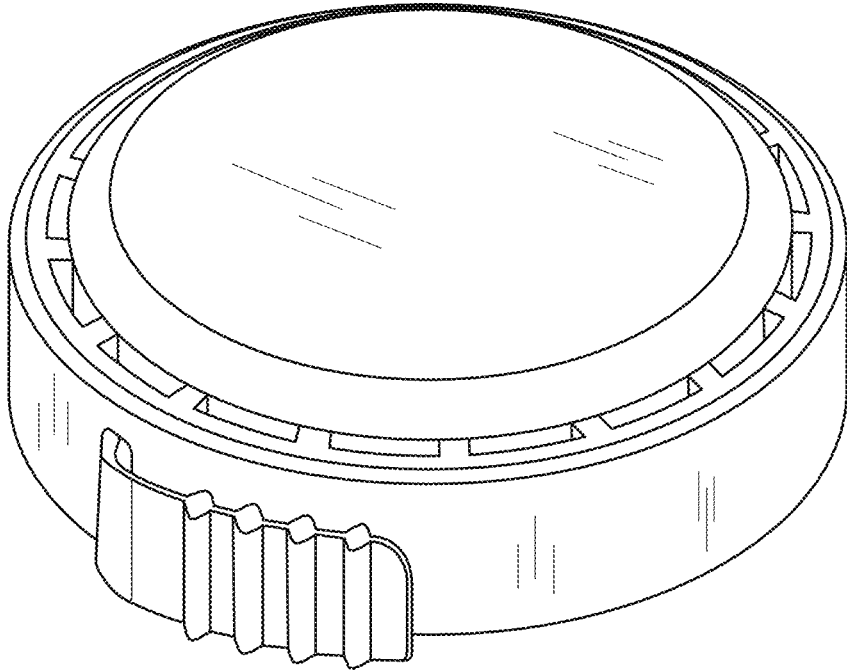

FIG. 1

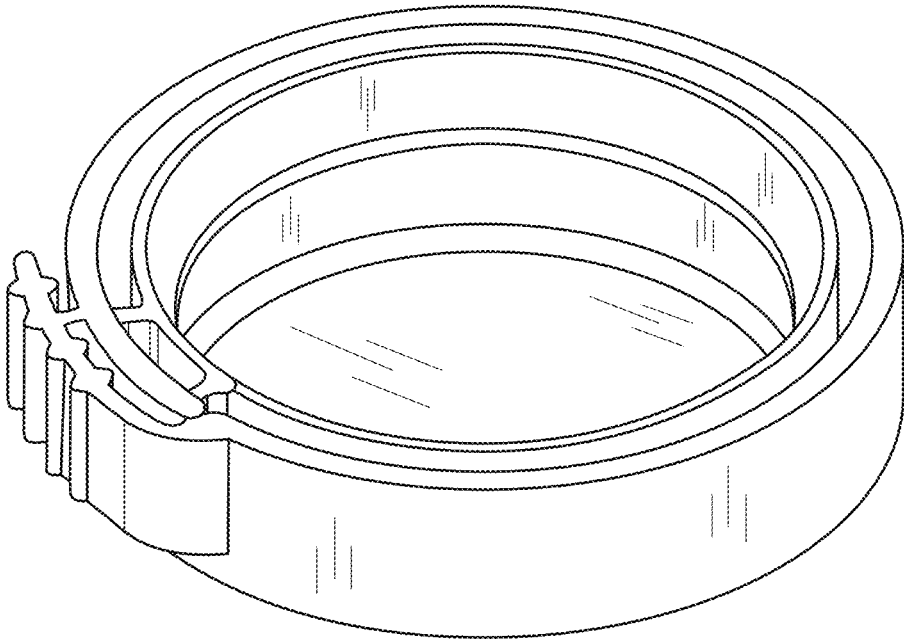

FIG. 2

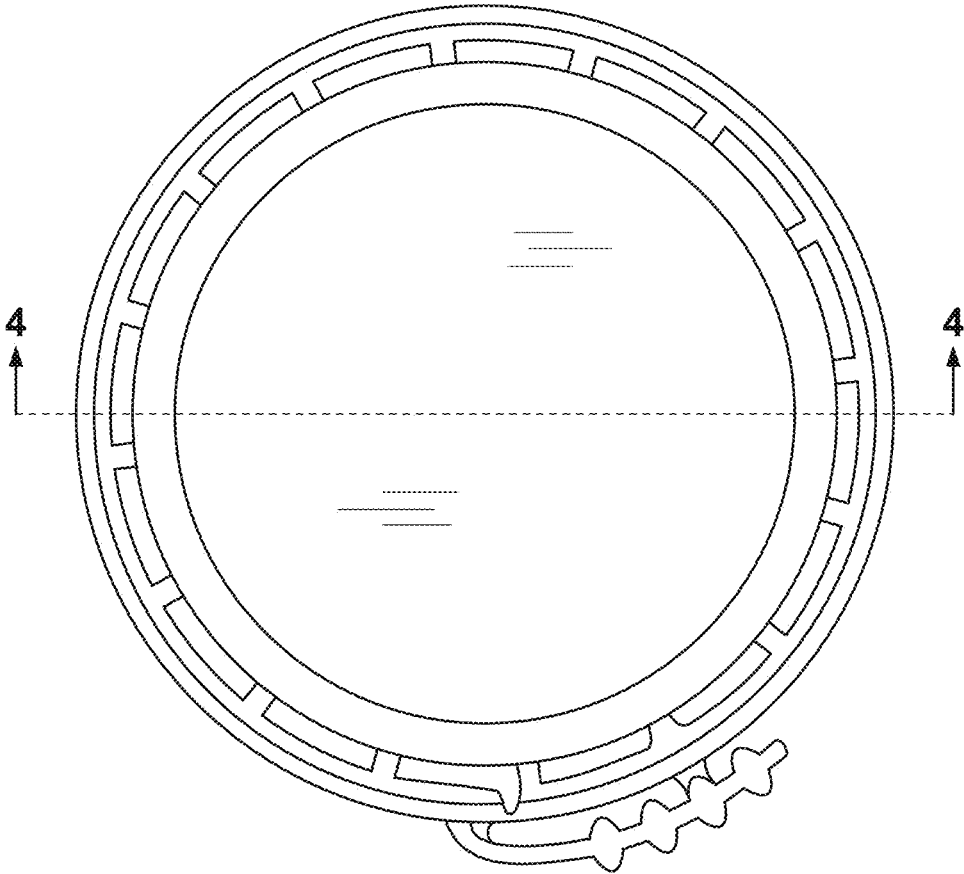

FIG. 3

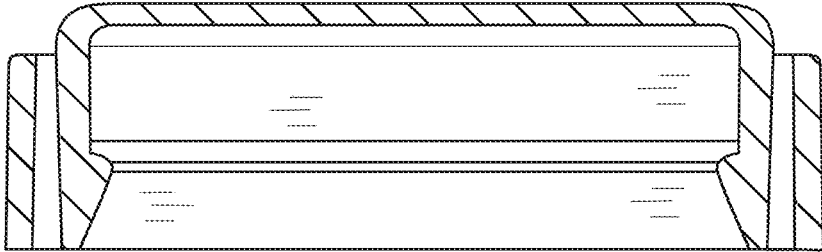

FIG. 4

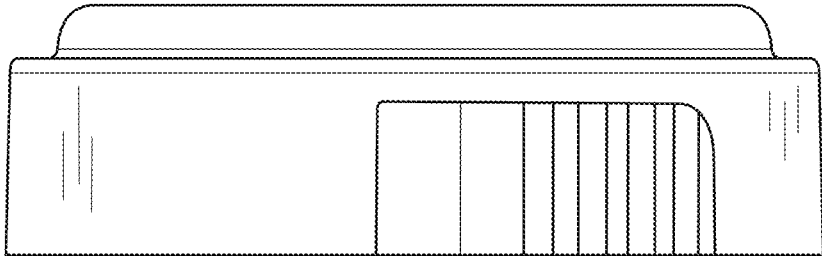

FIG. 5

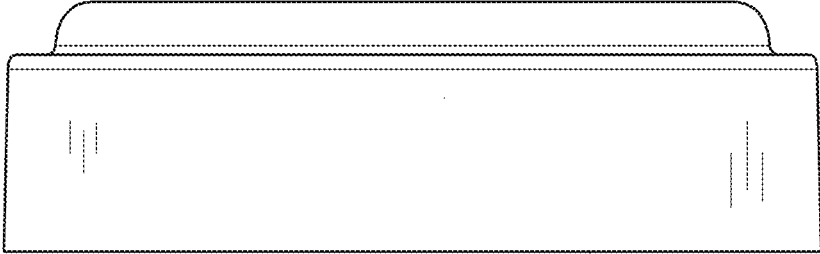

FIG. 6

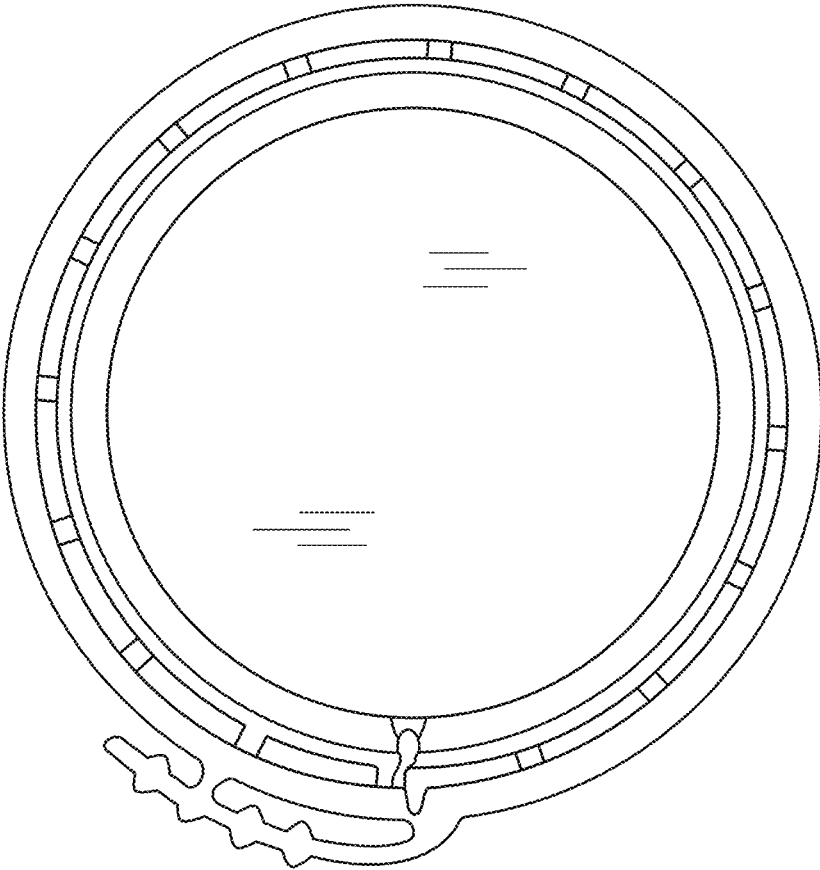

FIG. 7

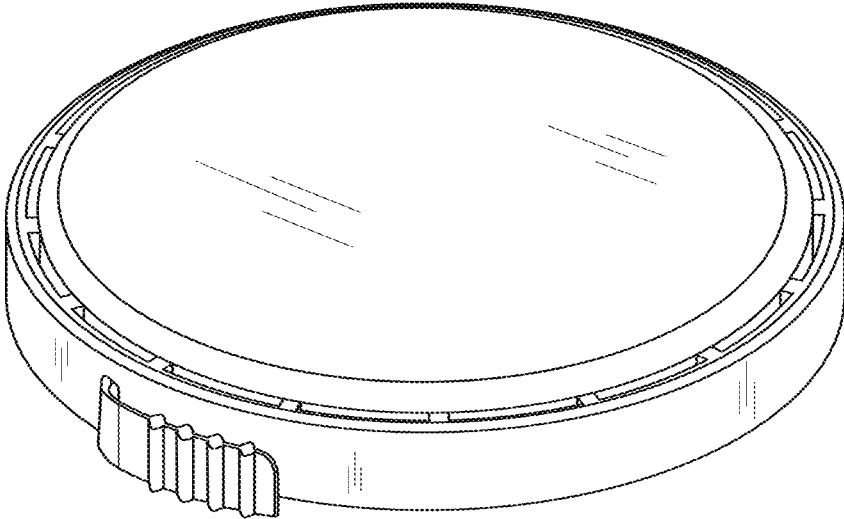

FIG. 8

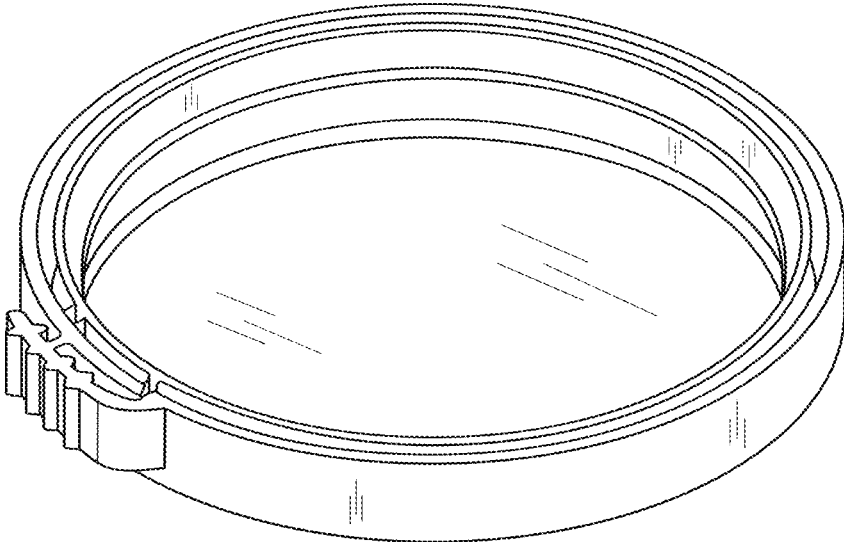

FIG. 9

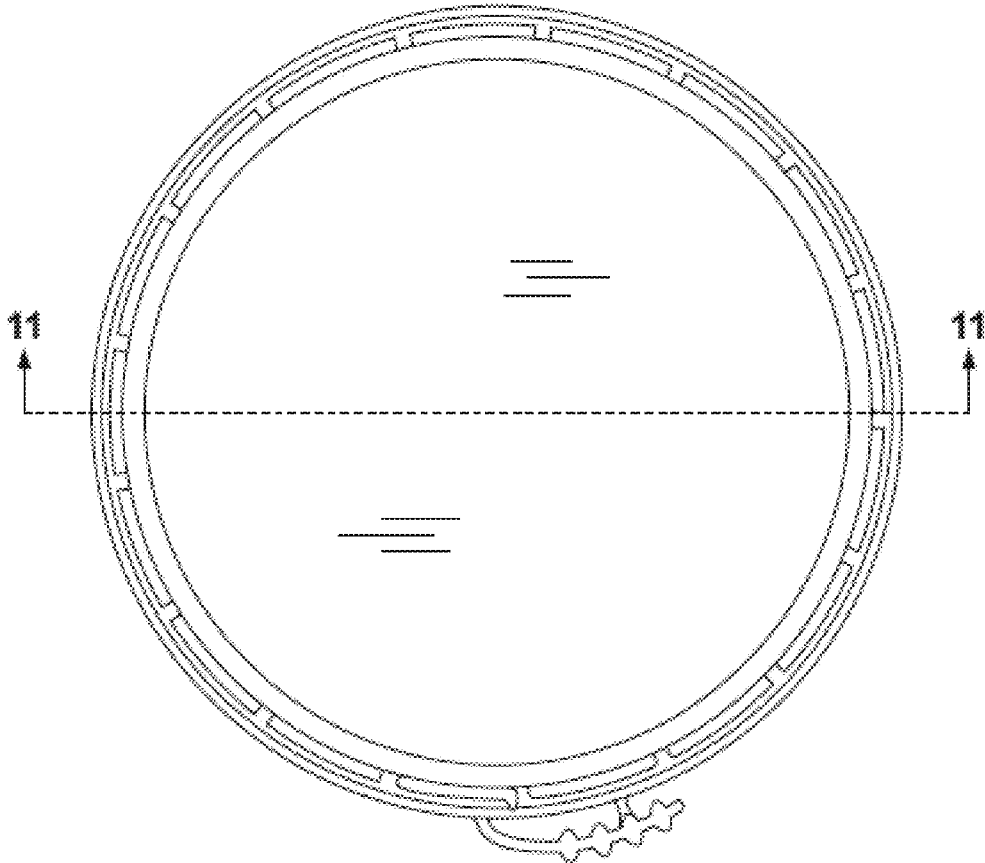

FIG. 10



FIG. 11

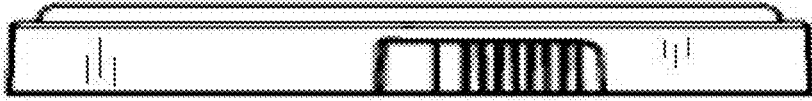

FIG. 12

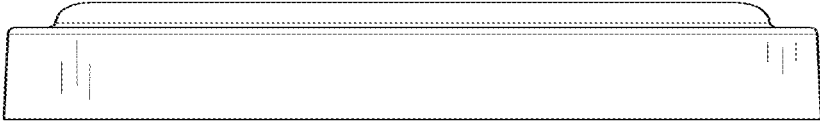

FIG. 13

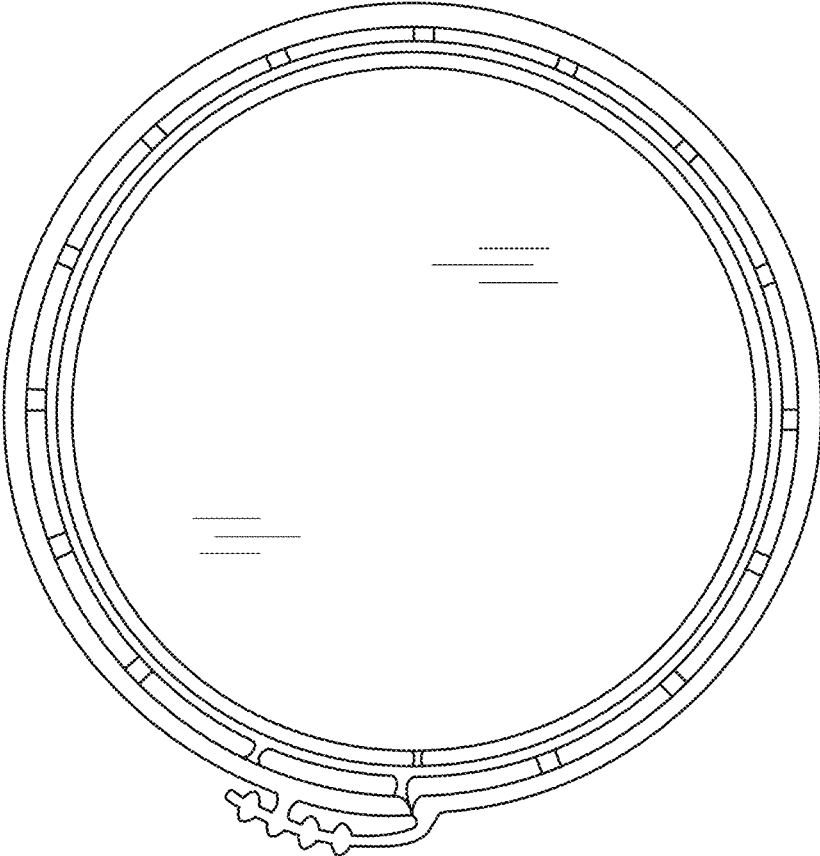

FIG. 14