

(12) UK Patent Application (19) GB (11) 2 277 781 (13) A

(43) Date of A Publication 09.11.1994

(21) Application No 9409048.7

(22) Date of Filing 06.05.1994

(30) Priority Data

(31) 4315256 (32) 07.05.1993 (33) DE

(71) Applicant(s)

MTU Motoren-und Turbinen-Union Munchen GmbH

(Incorporated in the Federal Republic of Germany)

Dachauer Strasse 665, 8000 Munchen 50,  
Federal Republic of Germany

(72) Inventor(s)

Heinrich Enderle  
Achim Ottenstein

(74) Agent and/or Address for Service

Marks & Clerk  
57-60 Lincoln's Inn Fields, LONDON, WC2A 3LS,  
United Kingdom

(51) INT CL<sup>5</sup>

F02K 1/82, F01D 25/14

(52) UK CL (Edition M)

F1T TFEA T109 T122  
F1J JDB J100 J103 J104 J106

(56) Documents Cited

GB 2249141 A GB 2060077 A GB 1103643 A  
GB 0740024 A US 5219268 A US 4631913 A

(58) Field of Search

UK CL (Edition M) F1G GCC GCX, F1J JDB, F1T TFEA  
INT CL<sup>5</sup> F01D 9/02 25/08 25/12 25/14, F02K 1/78 1/82  
9/40  
ON-LINE DATABASES: WPI

(54) Supplying and removing coolant to/from a turbine casing wall

(57) Means for distributing, supplying and removing a coolant to and from cooling channels 3', 4 in wall 1 comprise spatially-separated tubes 2, 3 arranged at the wall 1, a casing M', M of each tube 2, 3 having a longitudinal slot L. Each tube 2, 3 is attached at the inlet or outlet to the cooling channels 3', 4 by means of the longitudinal slot L and apertures 5', 5 in the wall 1, and each tube is soldered or welded in a sealing manner to the wall 1 at the longitudinal slot L.

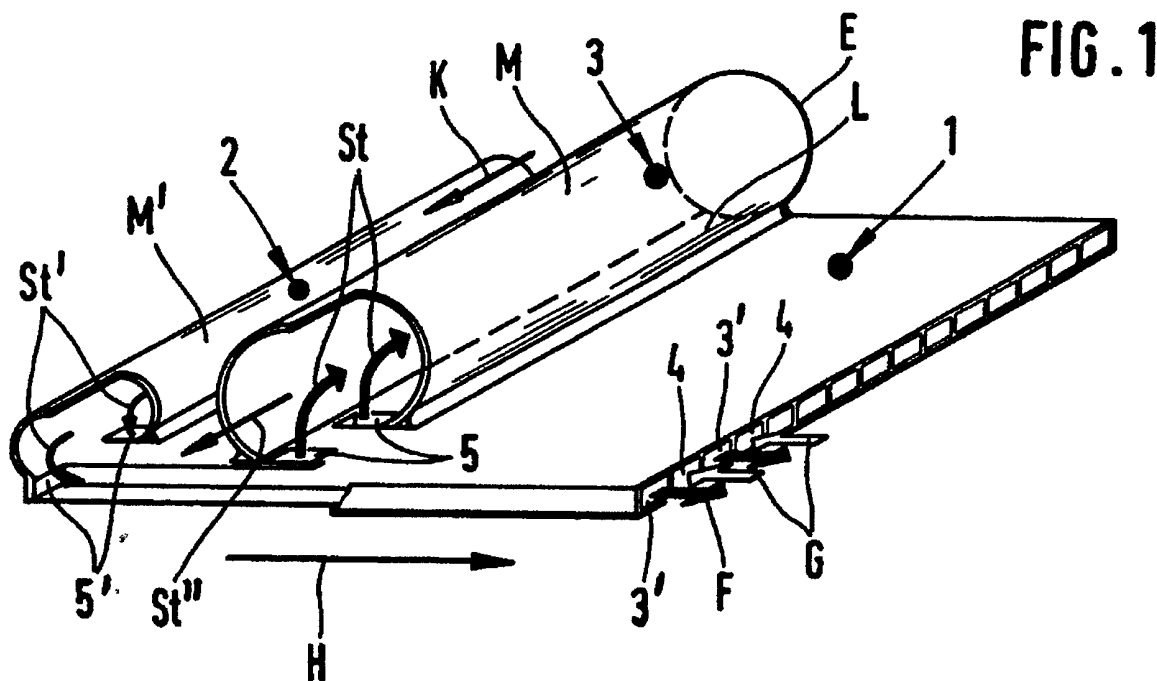

GB 2 277 781 A

FIG. 1

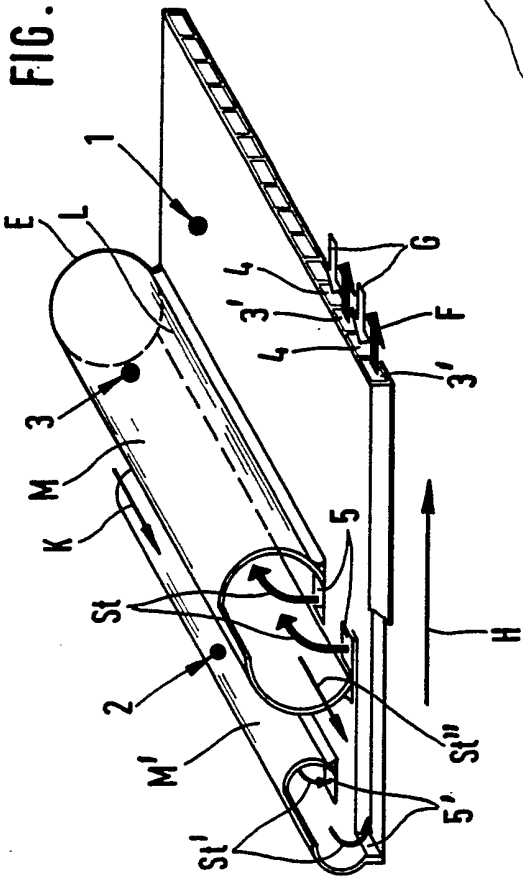

FIG. 2

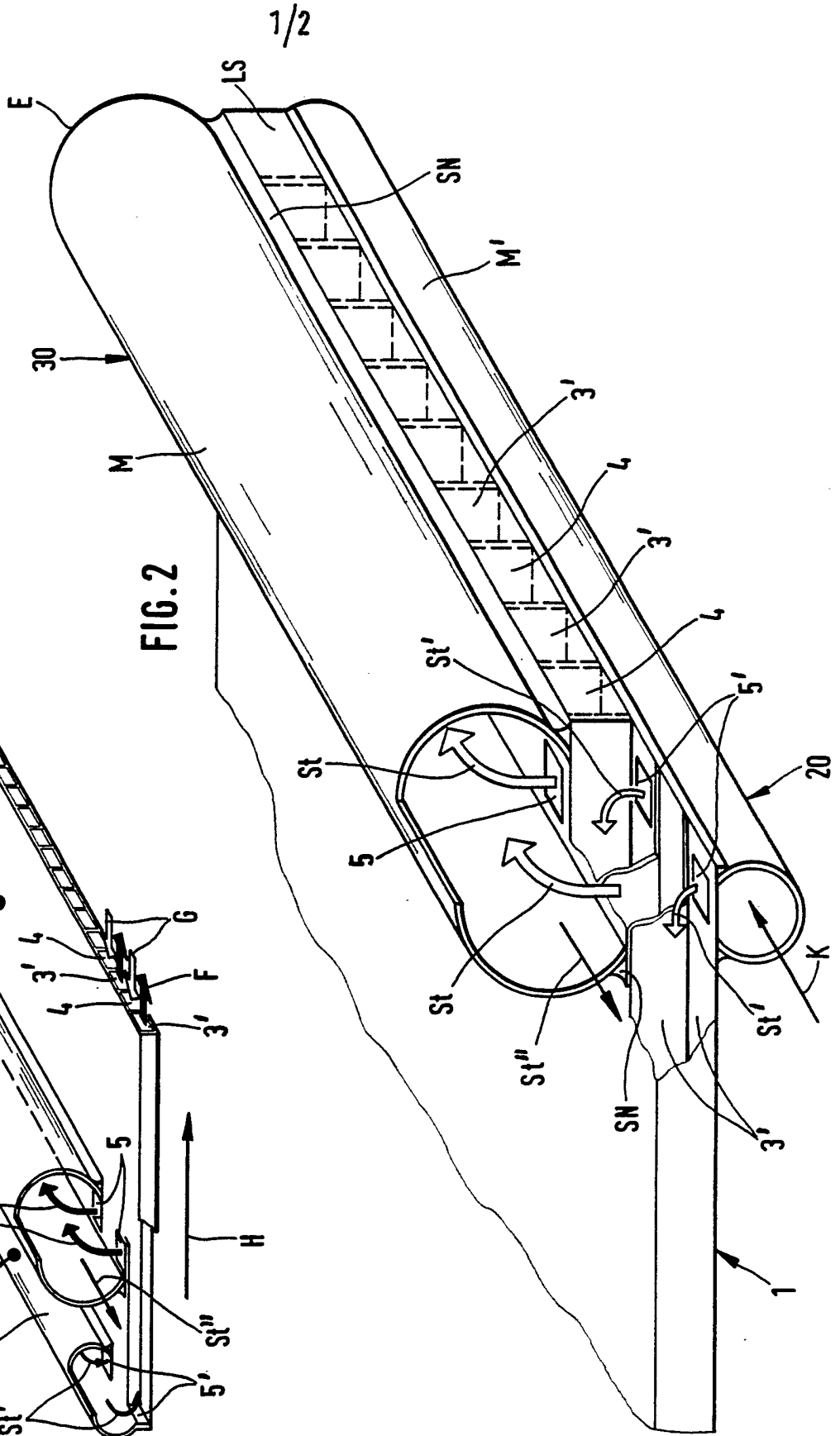

FIG. 3

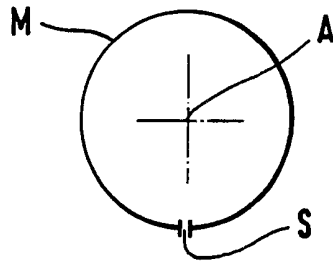

FIG. 4

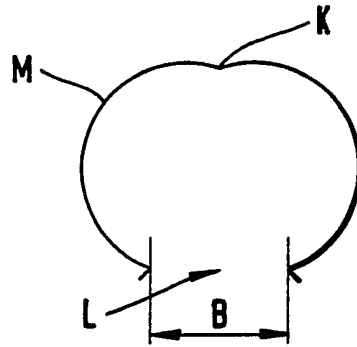

FIG. 5

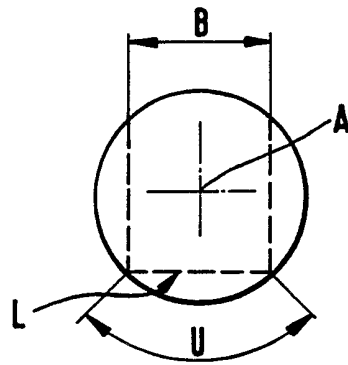
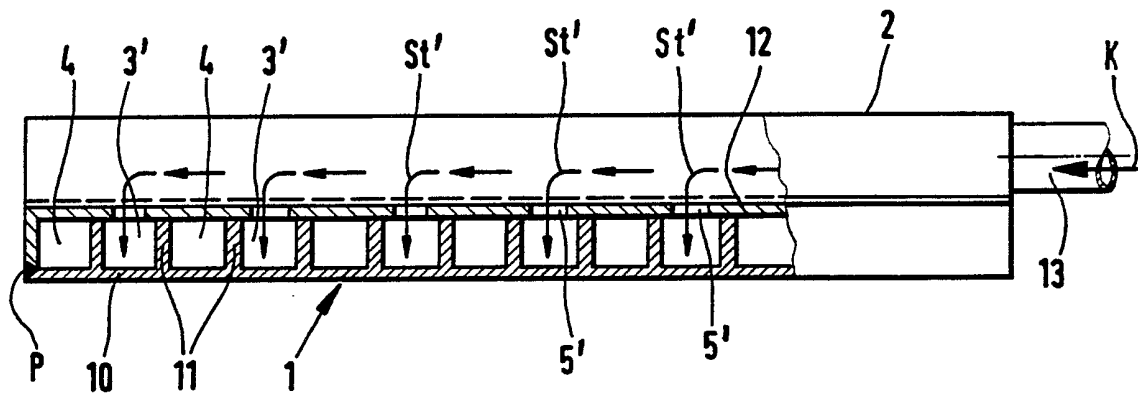

FIG. 6



A turbine engine wall having means for  
distributing and supplying and removing a  
coolant to and from the wall

The present invention relates to a turbine engine wall subjected, in use, to the flow of a hot fluid and having cooling channels arranged therein substantially parallel to one another, and for distributing, supplying and removing a coolant to and from the cooling channels.

Especially in the case of turbine dynamic jet engines, which are intended to enable operation in subsonic, supersonic and hypersonic flight, extremely high wall temperatures have to be accommodated; these are caused, for example, by the high temperatures of the dynamic compressed air (1500 K and above) in the operation of dynamic jet or hypersonic flight.

Extreme temperature loads and cooling requirements affect the following, inter alia: wall of variable inlet geometry; walls of flaps or slide valves which, in conjunction with central bodies, block the turbine engine when it is at a standstill on the side at which

air enters, and during such blocking guide the hot dynamic compressed air into an outer annular channel of the dynamic jet engine. Furthermore, hot gas temperatures at walls, for example, of the turbine housing and afterburner (turbine operation with/without afterburner), in particular extreme hot-gas temperatures at walls of a variable thrust nozzle responsible for the overall engine and thus also for hypersonic operation, have to be accommodated, notably at walls of the nozzle housing and for example at adjustable or stationary wall portions intended to provide the necessary narrowest cross-section of the thrust nozzle in conjunction with matching nozzle convergence/divergence. In this case, the necessary coolant can be provided from the cryogenically entrained propellant (hydrogen - liquid  $H_2$ ) which, for example with regenerative cooling, is supplied to the winding tubes of a hot-gas thrust nozzle wall and then, converted into a gas, fed for combustion.

Furthermore, it is known for the purpose of cooling the said wall or component to use, as the cooling air, air which is taken from the engine surroundings (upstream of the compressor of the basic or turbine engine), this air being guided by way of a condenser and liquified in heat exchange with the supplied fuel (e.g.  $H_2$ ) and either supplied in this state or in a vapour state for component cooling.

No comprehensible measures emerge from the prior art discussed as to the manner, preferably practical and simple from a structural point of view, in which the coolant (e. g.  $H_2$  or liquefied or vapour cooling air) would be supplied to individual cooling channels in wall components, or would be removed again therefrom, in such a way that a comparatively low-loss guidance of coolant which is hermetically sealed from the engine environment is achieved with highly effective cooling. Because of different local high-temperature loads, it will furthermore be necessary to provide variable levels of cooling effectiveness, it being necessary at the same time to keep the structural complexity of the cooling engineering as low as possible. A design which has already been proposed, with individual distributor hoses or tubes, which would each have to be attached individually to an individual cooling channel (on the supply or on the removal side), appears, in the context of what has just been said, as extremely complicated structurally and susceptible to disruption (continuous testing of individual seals).

An object of the invention is to provide a turbine engine wall in which the coolant can be supplied to or removed from all the cooling channels on the supply or removal side at the same time in a manner which is

optimized with respect to requirements and with a comparatively small structural complexity.

The invention provides a turbine engine wall as claimed in Claim 1.

The tube guides can be arranged at any desired position in relation to the cooling channel structure present and the supply or removal of coolant to and from the wall or wall component concerned.

Especially by varying the supply and removal openings or apertures, the supply or removal of coolant can be controlled in a comparatively simple manner; or, the necessary coolant rates and quantities or dwell times in the channels can be influenced thereby.

The invention is furthermore particularly suitable for guiding the coolant such that it flows entirely or in certain regions in counter-current.

Within the scope of the invention, it is possible for example for only every second or third successive cooling channel to be acted upon by the coolant by way of a tube guide.

By suitable choice of material, of the tube guide size

(length, cross-section) and of the tube guide shape, the respective thermal expansion can be adapted to operation in an optimum manner.

Because of the hermetically sealed longitudinal welding or hard soldering, individual welding and sealing connection techniques for each cooling channel are dispensed with. Moreover, a simple, low-cost manufacturing process is achieved. This is also true in respect of the possibility of bending open the casing of a tube guide to the required slot width or by cutting off the casing of a tube guide which is pre-fabricated to be approximately cylindrical, in an alternative procedure, parallel to the casing axis along a part of the periphery.

Advantageously, only a single sealing point is required for each tube guide, in particular at the point where the coolant, e.g.  $H_2$ , would have to be guided away at the exit from a tube guide, that is to say at one end side, into a further pipeline which is connected for example to the burner of a turbine dynamic jet engine.

Embodiments of the invention will now be described by way of example with reference to the accompanying drawings, wherein:

Fig. 1 shows a cooled thrust nozzle wall in a



perspective view, illustrated partially cut open,

Fig. 2 shows a cut-away portion of a cooled nozzle wall in perspective and illustrated partially cut open, with a double tube guide on the supply and on the removal side, separated spatially from one another, at one end region of the nozzle wall,

Fig. 3 shows a pre-fabrication phase of the cylindrical casing for a tube guide, with a peripheral severing cut axially parallel,

Fig. 4 shows the casing according to Fig. 3, widened to the required slot width along an axially parallel bending or fold line,

Fig. 5 shows a slot construction of the necessary length and width different from that of Figs. 3 and 4, in which a peripheral section of the cylindrical casing is cut off axially parallel, and

Fig. 6 shows a rear end view of a cooled thrust nozzle wall in relation to a tube guide and the cooling channels, with apertures in the wall, illustrated partially in section in the transverse direction and cut away.

Fig. 1 shows a thrust nozzle wall 1 with two tube guides 2, 3, arranged thereon and spatially separated from one another, namely a "distributor tube" and a "collection tube". On one side, here the inside, the thrust nozzle wall 1 is exposed to the flow of a hot gas H of extremely high temperature. For the purpose of coping with the temperature, the thrust nozzle wall 1 is cooled and has first and second cooling channels 3' and 4, respectively, which can be acted upon by means of a coolant, e. g. liquid hydrogen ( $H_2$ ), and which are integrated in the wall 1. Coolant flows through the first and second cooling channels 3' and 4, respectively, continuously in opposite directions to one another or in counter-current over a length portion, here to be understood as from the tube guide 3 towards the right-hand wall end (arrows F, G).

In relation to the said longitudinal portion, the first and second cooling channels 3' and 4, respectively, are arranged parallel and adjacent to one another and in the longitudinal direction within the thrust nozzle wall 1. The second cooling channels 4 (direction of throughflow G) end at the exit in apertures 5 on the outside of the thrust nozzle wall 1, the apertures 5 being connected to the interior of the tube guide 3 by way of a longitudinal slot L constructed in the casing M of the tube guide 3 (in this connection, see also Fig. 4 or 5);

the outgoing flow of the coolant through the apertures 5 into the tube guide 3 is in each case designated St. In a manner which is comparable with the tube guide 3, apertures 5' at the inlet are covered in sealed manner on the outside of the thrust nozzle wall 1, that is to say in this case at the left-hand wall end of the casing M' of the tube guide 2, the arrows St' designating the incoming flow of the coolant through these apertures 5' into (in this case) only every second successive first cooling channel 3' (direction of throughflow F).

In accordance with the invention - as illustrated in Fig. 1 - the casing M' of the tube guide 2 can at the same time be the covering means of the ends, in this case for example the left-hand ends, on the incoming flow side of the first cooling channels 3'. At the end E which is in this case on the flap valve side, the tube guide 3 should be understood as closed in the manner of a cover, in which case the coolant which in accordance with arrows St flows into the tube guide 3 can then be supplied in accordance with the direction of the arrow St" through an outgoing flow line (not illustrated) attached in a hermetically sealed manner to the tube guide 3, to a further consumer which is suitable for the engine. The other tube guide 2 can be acted upon by the coolant from the one end in accordance with the arrow K by way of a supply line (not illustrated) which is also

attached in a hermetically sealed manner. At the end opposite the arrow K, the other tube guide 2 should be closed on the wall side in the manner of a cover. The supply and distribution of the coolant to the second cooling channels 4 (direction of throughflow G) can usefully be performed through a tube guide which is located on the right-hand end on the outside of the thrust nozzle wall 1, this tube guide in principle corresponding to the already discussed second tube guide 2 at the left-hand outer end of the thrust nozzle wall 1. Similarly, a second tube guide 3 associated with the second tube guide 2 at the right-hand end of the thrust nozzle wall 1 receives coolant from the first cooling channels 3'.

At least in relation to the tube guides 2 and 3 (Fig. 1) it can be seen that they run transversely by means of their casings M' and M to the direction in which the cooling channels extend, and in this case are parallel to one another and spaced.

If one assumes for example that the wall component 1 in accordance with Fig. 1 is a pivotal flap valve of a thrust nozzle of square or rectangular cross-section, this flap valve adopting, together with the other flap valves, the respectively narrowest cross-section, then in the context of the measures according to the

invention an increased cooling performance can be provided in regions of high heat occurrence, for example in the vicinity of the nozzle neck; thus, the heat transfer resistance which is decisive for heat removal can be reduced locally or in certain portions.

Fig. 2 represents an alternative to the invention to the extent that a so-called "double tube arrangement" is constructed and arranged at the, in this case for example rear, end of the thrust nozzle wall 1, in particular in an arrangement where the fluids are separated from one another. A tube guide 20 is arranged on the supply side, similar to a distributor tube, on the inside of and below the thrust nozzle wall 1, and a tube guide 30 similar to a collection tube and parallel thereto, is arranged on the outside of and above the thrust nozzle wall 1, the reference numerals of Fig. 1 being used for hydrodynamic and aerodynamic criteria and incoming and outgoing flow and distribution criteria of the coolant. In this case, for example in accordance with Fig. 2, it is possible, using an integral or subsequently welded-in longitudinal portion LS of both casings M, M' of the tube guides 20, 30, to achieve at the same time a rear sealed blocking of the wall 1 and thus of the cooling channels 3' and 4, respectively.

In accordance with Fig. 3, each of the previously

discussed tube guides can be pre-fabricated from a cylindrical casing M, for example, which is severed at the point S along a surface line running parallel to the axis A. Thereafter, the casing M can be widened to the required width B of the longitudinal slot L, at least along a bending line or bending edge K which runs parallel to the axis A or to the widened casing centre.

However, in accordance with Fig. 5, each tube guide can also be produced from a cylindrical casing M from which part of the periphery U is cut off longitudinally to construct the longitudinal slot L of the required width B.

Using the same reference numerals for substantially unaltered components and functions, Fig. 6 represents an alternative in which the thrust nozzle wall 1 comprises a basic element 10 having depressions which are spaced by ribs 11 and which form the cooling channels 3' and 4, respectively, by ribs 11 and depressions being welded in a hermetically sealed manner to a cover element 12 (e.g. at point P), this cover element 12 having cutouts or removed portions for the apertures 5'. In this case, a line 13 which is connected in a fixedly sealed manner to the tube guide 2 is furthermore provided for supplying the coolant (arrow K).

SN designates weld or solder seams, which can in particular be seen in Fig. 2, for example for the tube guide 30, and it is thus also possible for a corresponding hermetically sealing soldering or welding to be carried out at the longitudinal slot L concerned (in this connection, see also Fig. 4 or 5) to the thrust nozzle wall 1, for all pipe guides.

The invention can be used with all walls or wall components of turbine or turbine dynamic jet engines which are subjected to high-temperature load, that is to say components like those specified for example in the introductory part of the description to the prior art.

## Claims

1. A turbine engine wall subjected, in use, to the flow of a hot fluid and having cooling channels arranged therein substantially parallel to one another, and means for distributing, supplying and removing a coolant to and from the cooling channels, wherein the said means comprise spatially-separated tube guides arranged at the wall, a casing of each tube guide having a longitudinal slot, each tube guide being attached at the inlet or outlet to the cooling channels by means of the longitudinal slot and apertures in the wall, and each tube guide being soldered or welded in a sealing manner to the wall at the longitudinal slot.

2. A turbine engine wall according to Claim 1, wherein each tube guide is closed at one wall side in the manner of a cover and is attached at the opposite wall side to an incoming or outgoing flow line for the coolant.

3. A turbine engine wall according to Claim 1 or 2, wherein the tube guides are constructed parallel to each other and are arranged at two opposite end regions of the wall.

4. A turbine engine wall according to Claim 1 or 2,



wherein two tube guides for respectively supplying and removing the coolant are constructed at least at one end region of a wall parallel to one another on the inside and outside of the wall and at the upper and lower sides of the wall respectively.

5. A turbine engine wall according to Claim 4, wherein one longitudinal portion of a casing common to both tube guides forms a closure which is soldered or welded in a hermetically-sealed manner to the cooling channel ends in the wall.

6. A turbine engine wall according to Claim 1 or 2, wherein two tube guides arranged parallel to one another are provided at the wall, of which the one is arranged in one end region of the wall and the other is arranged on one of both wall sides or on the outside or on the inside.

7. A turbine engine wall according to one or more of Claims 1, 2, 4, 5 and 6, wherein there are arranged in the wall in alternate succession opposed to one another first and second cooling channels for flow of coolant and of which the first channels are attached on the inlet side by way of apertures to the one tube guide, and the second channels are attached on the outlet side by way of apertures to the other tube guide.

8. A turbine engine wall according to Claim 7, wherein the apertures of the cooling channels have throughflow cross-sections of different sizes matched to the necessary degree of cooling effectiveness where there is a locally different high-temperature action on the wall.

9. A turbine engine wall according to Claim 1, 7 and 8, wherein the arrangement in alternating sequence of cooling channels for coolant flow in different directions, approximately parallel next to one another, is restricted to at least one wall portion.

10. A turbine engine wall according to Claim 1 and adopted so that the coolant flows through different numbers of cooling channels, distributed locally in groups over the wall, in the same direction or successively opposed to one another.

11. A turbine engine wall according to one or more of Claims 1 to 10, wherein the tube guides are made from a cylindrical casing from which part of the periphery is cut longitudinally to form the longitudinal slot of the required width.

12. A turbine engine wall according to one or more of Claims 1 to 10, wherein the tube guides are formed from a cylindrical casing severed along an axially parallel

line and widened to the required width of the longitudinal slot.

13. A turbine engine wall according to Claim 12, wherein the casing of the tube guides is widened to the required slot width along at least one axially parallel bending line, bending edge or bead.

14. A turbine engine wall according to one or more of Claims 1 to 13, wherein the cooling channels have a square or rectangular throughflow cross-section and the wall is composed of square or rectangular cooling channels, the apertures being formed by locally omitted or cut-away sections of the cooling channel walls.

15. A turbine engine wall according to one or more of Claims 1 to 14, wherein the wall comprises a base member having depressions which are spaced by ribs and which form the cooling channels by covering the ribs and depressions by means of a cover element having cutouts or cut-away portions for the apertures.

16. A turbine engine wall substantially as herein described with reference to any of the embodiments shown in the accompanying drawings.

Examiner's report to the Comptroller under Section 17  
(the Search report)

-17-

**Relevant Technical Fields**

- (i) UK Cl (Ed.M) F1J (JDB); F1G (GCC, GCX); F1T (TFEA)  
(ii) Int Cl (Ed.5) F01D 25/08, 25/12, 9/02; F02K 1/82, 1/78,  
9/40

Search Examiner  
M D WALKERDate of completion of Search  
3 AUGUST 1994**Databases (see below)**

(i) UK Patent Office collections of GB, EP, WO and US patent specifications.

(ii) ON-LINE DATABASES: WPI

Documents considered relevant  
following a search in respect of  
Claims :-  
ALL**Categories of documents**

- X:** Document indicating lack of novelty or of inventive step.      **P:** Document published on or after the declared priority date but before the filing date of the present application.
- Y:** Document indicating lack of inventive step if combined with one or more other documents of the same category.      **E:** Patent document published on or after, but with priority date earlier than, the filing date of the present application.
- A:** Document indicating technological background and/or state of the art.      **&:** Member of the same patent family; corresponding document.

Category	Identity of document and relevant passages	Relevant to claim(s)
Y	GB 2249141 A (MTU) Figure 2	1, 7
Y	GB 2060077 A (SNECMA) page 2 lines 40-52; lines 115-128	1, 2
Y	GB 1103643 (ROLLS ROYCE) page 2 lines 49-92	1-3 at least
Y	GB 0740024 (BROWN, BOVERI) page 1 lines 45-54	1, 2 at least
Y	US 5219268 (JOHNSON) column 5 line 18 etc	1, 2, 14, 15
Y	US 4631913 (KREITMEIER) Figure 2	1, 2

**Databases:**The UK Patent Office database comprises classified collections of GB, EP, WO and US patent specifications as outlined periodically in the Official Journal (Patents). The on-line databases considered for search are also listed periodically in the Official Journal (Patents).