



(12) **EUROPEAN PATENT APPLICATION**

(43) Date of publication:  
**09.03.2005 Bulletin 2005/10**

(51) Int Cl.7: **B25G 1/06, B25B 15/00**

(21) Application number: **03019992.1**

(22) Date of filing: **03.09.2003**

(84) Designated Contracting States:  
**AT BE BG CH CY CZ DE DK EE ES FI FR GB GR  
HU IE IT LI LU MC NL PT RO SE SI SK TR**  
Designated Extension States:  
**AL LT LV MK**

(72) Inventor: **Warner, Mark S.  
Mission Viejo California 92691 (US)**

(74) Representative: **Becker Kurig Straus  
Patentanwälte  
Bavariastrasse 7  
80336 München (DE)**

(71) Applicants:  
• **Petersen, Paul  
Irvine, CA 92604 (US)**  
• **Warner, Mark S.  
Mission Viejo, California 92691 (US)**

Remarks:  
Amended claims in accordance with Rule 86 (2)  
EPC.

(54) **Wrenches having two driving stems pivotally connected with each other**

(57) A wrench having two driving stems (10,12) pivotally connected with each other. One of the driving stems has a main stem and a female joint protruding from a rectangular or cylindrical section of the main stem with a hole at a center thereof. The other driving stem has the other main stem and a male joint projecting out of the center of a rectangular or cylindrical section of the main stem. The male joint and the female joint are engaged with each other via a coupler such as a roll pin (14). Therefore, without using an additional hinge or other mechanical coupler, these two driving stems are pivotally connected with each other.

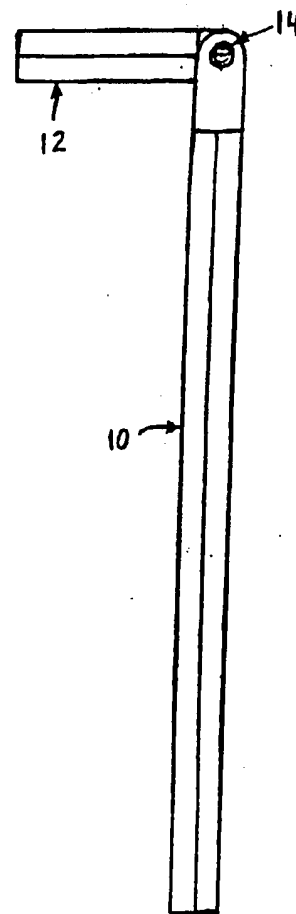
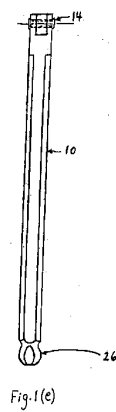
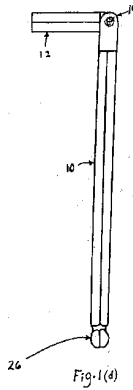
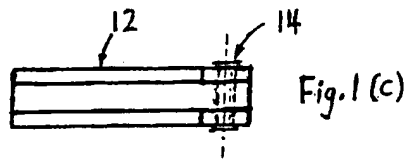

Fig. 1(a)



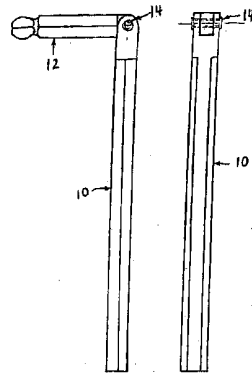

FIG. 1(f)

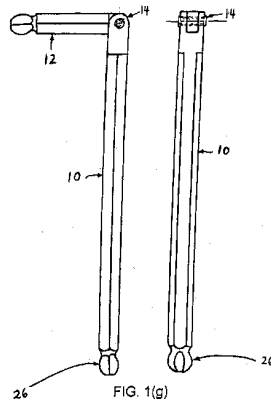

FIG. 1(g)

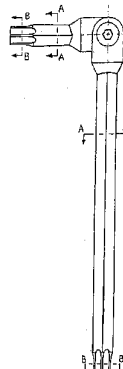

Fig. 1(h)



Fig. 1(i)



Fig.1(j) CROSS-SECTION  
VIEW A-A

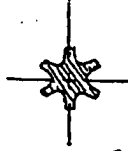

Fig.1(k) CROSS-SECTION  
VIEW B-B

**Description**BACKGROUND OF THE INVENTIONField of the Invention

**[0001]** The invention relates in general to a wrench having two driving stems pivotally connected with each other. More particularly, this invention relates to a hex key type or Allen wrench having two individual driving stems pivotally connected with each other.

Description of the Related Art

**[0002]** A conventional wrench, for example, an Allen wrench, used for gripping and turning or twisting the head of a bolt, a cap screw, a nut, a pipe, or the like commonly comprises a one-piece L-shape metal with one end used as the driving stem and the other end used as a handle.

**[0003]** In US Patent No. 5,943,925, Huang discloses a tool having a foldable structure. The foldable structure disclosed by Huang comprises a coupler pivotally coupled between a driving stem and a handle. Applying the foldable structure to the Allen wrench, the driving stem can be folded in parallel with the handle, that is, with a zero angle relative to the handle. This results in a more compact space for storing the tool. In Huang, with respect to the handle, the driving stem can be rotated from an angle of zero degrees to an angle of 180 degrees. While turning a bolt in a limited space, for example, around the boundary of two perpendicularly joint planes, the handle of the Allen wrench adopting the foldable structure disclosed by Huang can only be turned between zero degrees to 180 degrees along a surface perpendicular to the driving stem. When a half circle of the turning action is complete, the user has to disengage the wrench from the bolt. By repositioning the handle to the original point of the turning action, the turning action is repeated until the bolt is fastened as required.

**[0004]** In other words, while tightening/untightening a screw, a bolt or a nut in a plane with a limited degree of freedom, a user may need to repeat engaging and disengaging the driving stem to reposition the handle. Moreover, using this conventional structure, there is only one end of the wrench that can be used as the driving tool while the other end is used as a handle only. When a different torque is required, or a screw, a bolt or a nut with different depth is to be driven thereby, a different driving stem has to be connected and reassembled.

SUMMARY OF THE INVENTION

**[0005]** The invention provides a wrench having two driving stems pivotally connected with each other. One of the driving stems has a female fork joint protruding from the main stem with a hole at the center thereof. The other driving stem has a male connecting joint protrud-

ing from the axial center of the main stem. The male joint and the female joint are engaged with each other via a connector such as a roll pin. Therefore, without using an additional hinge or other mechanical coupler, these two driving stems are pivotally connected with each other. One of these two pivotally connected driving stems flips from an angle of about 90 degrees to an angle of about 270 degrees relative to the other.

**[0006]** Thus arranged, one of the driving stems used as a handle can flip with an angle from about 90 degrees to about 270 degrees with respect to the other of the driving stems used for driving a screw, a bolt or a nut. Therefore, when the rotation of the handle is obstructed, the handle can be lifted up or down to perform fastening or removing. The specific flipping angle of the handle actually depends on the distance between the driving stems. That is, the handle can also be flipped from an angle less than 90 degrees to an angle larger than 270 degrees.

**[0007]** The applicability of the wrench structure provided by the invention is also applicable for driving a socket head screw, bolt or nut, including bolts or screws having a "star" shaped heads commonly referred to as the Torx ® tips, in a space with limited degree of freedom. For example, in the situation that the rotation of the handle is obstructed by the presence of an object. For example, while driving a socket head cap screw on a plane with a second plane protruding nearby, the screw is engaged with the driving stem, and the handle is turned to drive the driving stem, so as to thread/unthread the screw. Being obstructed by the protruding object, the rotating range of the handle is limited within a certain angle along a surface parallel to the first plane. When the rotating action of the handle is from one end to the other, that is, from an angle of zero degree to the certain degree along the surface, the user does not need to disengage the driving stem from the nut. Instead, the user can simply flip the handle to the other end, that is, from the angle of 90 degrees to 270 degrees relative to the driving stem, and carry on driving the screw.

**[0008]** In addition, with the structure of two driving stems pivotally connected together, one may choose either one of the driving stems as a handle, and the other driving stem to engage and drive an object, for example, a screw, a nut, a bolt, including bolts or screws having a "star" shaped heads commonly referred to as the Torx ® tips or the like. When an object with a different depth is to be engaged and driven, or when a different torque is required, one may interchange the functions of these two driving stems. Further, in certain circumstances, the user may choose to align the two stems with each other (at zero degree angle) and drive the object by applying a socket wrench to the free end of the stem opposite the driving stem.

**[0009]** Both the foregoing general description and the following detailed description are exemplary and explanatory only and are not restrictive of the invention, as claimed.

## BRIEF DESCRIPTION OF THE DRAWINGS

### [0010]

Figure 1(a) to Figure 1(k) are side and front views of a wrench with one driving stem positioned perpendicularly to the other driving stem in accordance with the present invention;

Figure 2(a) to Figure 2(d) show different views of one of the driving stems with a female joint in accordance with the present invention;

Figure 3(a) to Figure 3(d) show different views of one of the driving stems with a male joint in accordance with the present invention;

Figure 4 shows the method of assembling two driving stems in accordance with the present invention;

Figure 5(a) to Figure 5(d) are different views of a driving stem with a male joint in another embodiment according to the invention (i.e., an alternative design with greater strength male joint); and

Figure 6(a) to Figure 6(d) are different views of a driving stem with a female joint in another embodiment according to the invention (i.e., an alternative design with greater strength female joint.)

## DESCRIPTION OF THE PREFERRED EMBODIMENTS

[0011] Figures 1(a) to 6(e) illustrate the present invention embodied by a hex-key type or Allen wrench with two driving stems pivotally connected with each other. Being pivotally connected, one of the driving stems is used as a handle to drive the other driving stem so that an object such as a socket head nut, screw or bolt can be threaded or unthreaded. When one is threading/unthreading the object, the handle can be flipped from an angle of about 90 degrees to about 270 degrees with respect to the driving stem used to unthread/unthread the object. In this manner, even with the presence of an object that obstructs the threading/unthreading operation, the user does not need to disengage the object and rotate the handle to carry on threading/unthreading. Instead, one can simply flip over the handle and repeat rotating the handle to complete the threading/unthreading operation. In addition to the application of a hex-key or Allen wrench, it is appreciated that people of skill in the art may modify the disclosure of this embodiment and apply to other types of driving tools such as a box wrench, an open-end wrench, a socket wrench, or the like.

[0012] Figure 1(a) shows a side view of the wrench comprising two driving stems pivotally connected with each other. In this embodiment, a roll pin 14 is used to thread through each of the driving stems. It is appreciated that the roll pin 14 can also be replaced with other similar coupler such as a set of bolt and nut. The usage of the roll pin 14 can be clearly observed from the partly exploded front views as shown in Figure 1(a) and Figure

1(b). Figures 1(a) to 1(c) all show the wrench with the driving stems 10, 12 positioned perpendicularly with each other.

[0013] As an alternative configuration, Figures 1(d) and 1(e) show the wrench having an end with cut away groove and rounded stem end corners 26 at one end of the driving stem 10. Said rounded end is designed for ease of engaging the wrench with the fastening device such as a screw, a bolt, or a nut. As an alternative configuration, Figure 1(f) shows the cut away groove and rounded stem end corners 26 at one end of the driving stem 12. As another alternative configuration, Figure 1(g) shows the cut away groove and rounded stem end corners 26 being at one end of the driving stem 10 and at one end of the driving stem 12. Figures 1(h) and 1(i) are side and frontal views of the wrench with Torx® tips at of both short and long driving stems. Although not shown, it is possible to have the Torx® tip be placed at just the short driving stem or be placed at just the long driving stem. Figures 1(j) and (k) are the cross-sectional views of the driving stems.

[0014] Figures 2(a) and 2(b) show both the side view and the front view of the driving stem 10 of the wrench. As shown in Figure 2(a), the driving stem 10 comprises a female joint at one end thereof. At the end of the driving stem 10, a rectangular section extends from the driving stem, and two fillets 16 with equal dimensions stand out from two opposite edges of the rectangular section and leave a space in between. Figure 2(c) shows a cross sectional view of the driving stem 10 cutting along the line II-II. As shown in Figure 2(c), the cross section of the driving stem 10 is a hexagon with a width of  $d$  for each side. The cant of each side is about 60 degrees.

[0015] As illustrated in Figure 2(d), the width of the fillets 16 is equal to  $\sqrt{3}d$ , and the thickness of each plate is equal to half of the length of each side, that is,  $d/2$ . It is appreciated that the thickness and width are not limited only to such magnitudes and the wrench can still work properly while the thickness of the fillets vary. Referring to Figure 2(b), each of the fillets 16 has a hole in the center thereof. The holes of both fillets 16 align with each other such that a roll pin 14 as shown in Figure 1(a) can thread through both holes.

[0016] Figures 3(a) to 3(c) show the driving stem 12 with a male joint 22. The male joint 22 includes a projection of rectangular cross section which protrudes from a central portion of one end from one side to the opposite side of the driving stem 12. The male joint 22 has a thickness to be fitted into the space between two fillets 16 of the female joint of the driving stem 10. Preferably, the thickness is approximately equal to the length  $d$  of one side of the driving stem 10. The width of the projection 22 is about  $\sqrt{3}d$ .

[0017] Figure 3(c) shows a cross sectional view of the driving stem 12 along the cutting line III-III. It is clearly seen that the driving stem 12 has a hexagon cross section with each side having a width of  $d$ . A top view of the male joint on top of the driving stem 12 is shown as Fig-

ure 3(d). The male joint also has a hole in the center thereof to enable the roll pin 14 to thread through as shown in Figure 3(b). Referring to Figure 3(b), the male joint is a dome like structure having a width approximately the same as the width of the space between the fillets 16 in the driving stem 10. Thus, these two stems 10 and 12 are pivotally coupled to each. One can thus flip one of the driving stems 10 and 12 from an angle of 90 degrees to an angle of 270 degrees with respect to the other driving stem.

**[0018]** Figure 4 shows the assembly of the driving stems 10 and 12. The length of both driving stems 10 and 12 can be varied according to specific requirement. Preferably, the driving stem 10 with a female joint is longer than the driving stem with a male joint. While assembling as shown in Figure 4, for example, the driving stem 12 is approaching the driving stem 10 with the male joint towards the female joint along the direction of arrow 42. Being engaged with the driving stem 10, a roll pin 14 threads into the holes of the male and female joint to fasten the driving stems 10 and 12 to an extent that one of them can flip over the other. Radial compression of the roll pin while being inserted provides some rotational resistance to the rotating action. The direction to thread the roll pin 14 through both the driving stems 10 and 12 is illustrated as the arrow 41.

**[0019]** Figure 5(a) to Figure 6(e) show another embodiment according to the invention. In Figure 5(a) to Figure 5(e), a driving stem with another type of male joint is illustrated, while in Figure 6(a) to Figure 6(e), a driving stem with another type of female joint is illustrated. In this embodiment, preferably, the driving stem with a male joint is shorter than the driving stem with a female joint.

**[0020]** Figure 5(a) and Figure 5(b) are a side view and front view of the driving stem with a male joint. In Figure 5(a), one end of the driving stem 52 comprises a male joint portion 54. The male joint portion further comprises a base portion 54a extending from the main stem of the driving stem 52 with a curved bottom and a flat top. On top of the flat top of the base portion 54a, there is a flat plate 54b, and at the central portion of the flat plate 54b, a fillet 54c stands out. The side view of such male joint portion 54 is shown in Figure 5(b).

**[0021]** A cross sectional view cutting along the line V-V is shown as Figure 5(c). The cross section of the main stem of the driving stem 52 is in a hexagonal shape with each side having a width of  $d$  and a cant of about 60 degrees.

**[0022]** A top view of the male joint portion 54 is shown as Figure 5(d). From the top view, the male joint portion 54 is like a circle that covers the whole cross section of the main stem. The thickness of the fillet 54c is approximately equal to  $d$ , and the width of the fillet 54c, that is, the diameter of the male joint base portion 54b is substantially larger than  $\sqrt{3}d$ .

**[0023]** In addition, as shown in Figure 5(e), the edge 50 of the fillet 54c has been rounded. Figure 6(a) and

Figure 6(b) are a side view and front view of the driving stem 62 with a female joint 64. In Figure 6(a), one end of the driving stem 62 comprises a female joint portion 64. The female joint portion further comprises a base portion 64a extending from the main stem of the driving stem 62 with a curve bottom and a flat top. Protruding from the cylindrical base portion 64, there is a fork-like structure 64b that allows the fillet 54c of the driving stem 52 in Figure 5(a) to be engaged therein. The fork-like structure, as shown in Figure 6(a), comprises a slotted extension of the cylindrical base portion 64 with a rounded end as shown by Figure 6(b), thereby forming two prongs with flat machined interior faces and cylindrical curved outer surfaces as shown by Figures 6(a) and 6(d).

**[0024]** The side view of such female joint portion 64 is shown in Figure 6(b). A cross sectional view cutting along the line VI-VI is shown as Figure 6(c). The cross section of the main stem of the driving stem 62 is a hexagonal shape with each side having a width of  $d$  and a cant of about 60 degrees. A top view of the female joint portion 64 is shown as Figure 6(d). From the top view, space allowing the fillet 54c to be engaged therein has a thickness of approximately  $d$ , and the base section diameter of the female joint portion 64 is much larger than  $\sqrt{3}d$  with exact dimension based on strength calculations.

**[0025]** Other embodiments of the invention will appear to those skilled in the art from consideration of the specification and practice of the invention disclosed herein. It is intended that the specification and examples to be considered as exemplary only, with a true scope and spirit of the invention being indicated by the following claims.

## Claims

### 1. A pivotal wrench comprising:

a first driving stem, comprising further:

a main hexagonal stem;  
an enlarged female joint section at the proximal end of the first driving stem comprising:

a conical transition section; and  
a cylindrical or square base section further comprising two fillets protruding from two opposite sides of the base section with a space in between wherein each fillet comprises a hole;

a second driving stem, comprising further:

a main hexagonal stem;  
an enlarged male joint section at the

proximal end of the second driving stem comprising:

a conical transition section; and  
a cylindrical or square base section further comprising a fillet extending out at the center of the base section wherein the fillet comprises a hole;

5

10

an engaging means being threaded through the holes of the female joint section fillets of the first driving stem and the hole of the male joint section fillet of the second driving stem wherein the male joint fillet is engaged within the space between the two female joint fillets.

15

2. The pivotal wrench according to Claim 1, wherein the engaging means includes one or a combination of a roll pin or solid pin, a machine screw, a bolt and nut, a washer or washers, and a rivet. 20
3. The pivotal wrench according to Claim 1, wherein the first and second driving stems each have a rounded proximal end in order to flip over the other driving stem. 25
4. The pivotal wrench according to Claim 1, wherein the first and second driving stems are of different lengths but wherein the main hexagonal stem sections are of the same cross sectional size and shape. 30
5. The pivotal wrench according to Claim 1, wherein the distal end of the first driving stem has rounded corners and a cut-away groove between said rounded corners and the main hexagonal section of said driving stem, wherein said feature is commonly referred to as a "ball end". 35  
40
6. The pivotal wrench according to Claim 1, wherein the distal end of the second driving stem has rounded corners and a cut-away groove between said rounded corners and the main hexagonal section of said driving stem, wherein said feature is commonly referred to as a "ball end". 45
7. The pivotal wrench according to Claim 1, wherein the distal end of the first driving stem comprises an axial extension of the main hexagonal section of said driving stem with said axial extension having a star or multi-splined cross sectional shape suitable for engaging the inner surface of a fastener socket of complementary cross-sectional shape. 50  
55
8. The pivotal wrench according to Claim 1, wherein the distal end of the second driving stem comprises

an axial extension of the main hexagonal section of said driving stem with said axial extension having a star or multi-splined cross sectional shape suitable for engaging the inner surface of a fastener socket of complementary cross-sectional shape.



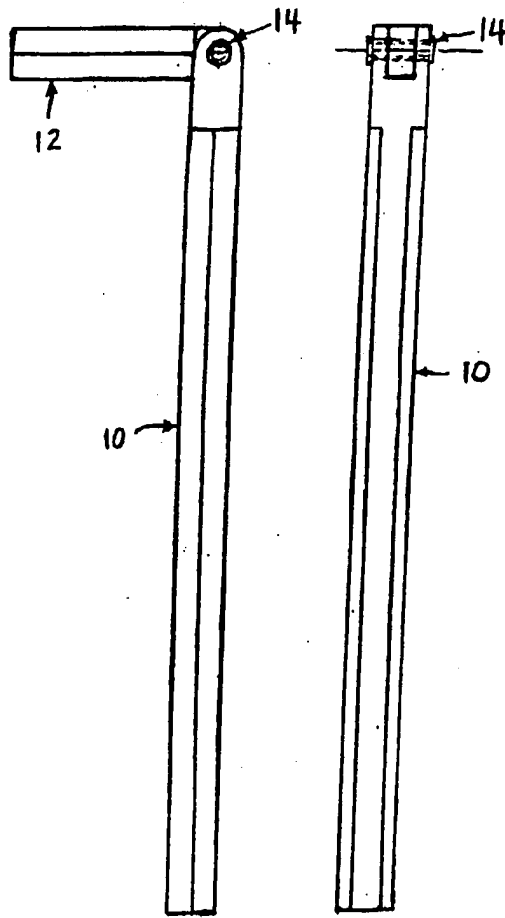
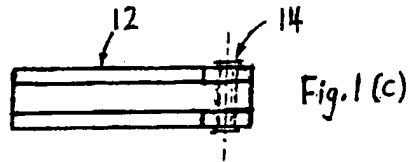
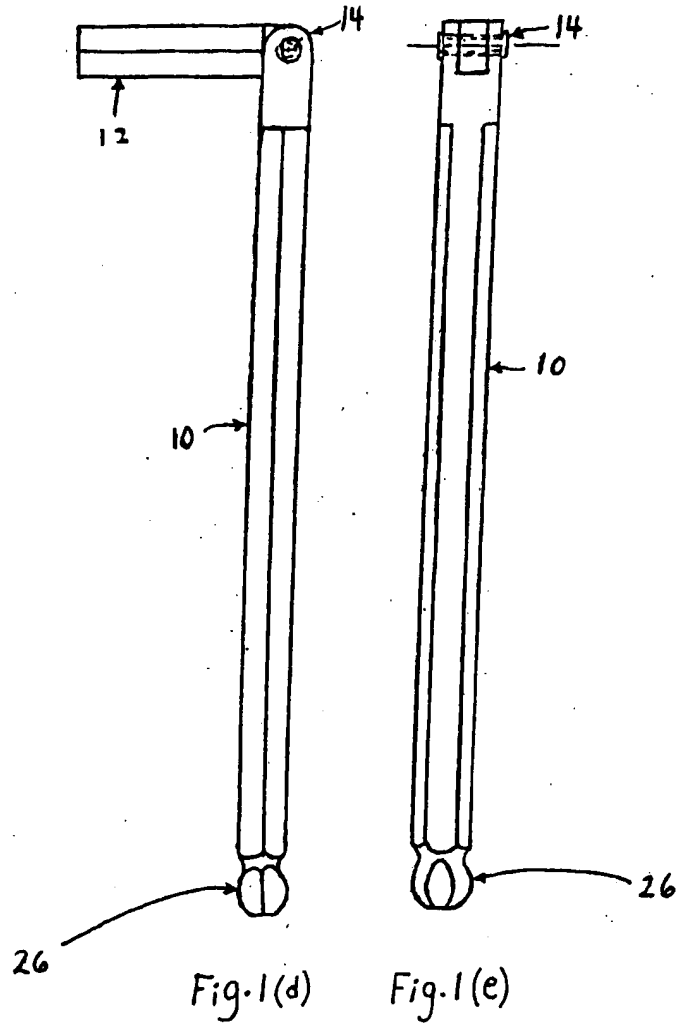

Fig. 1(a) - Fig. 1(b)



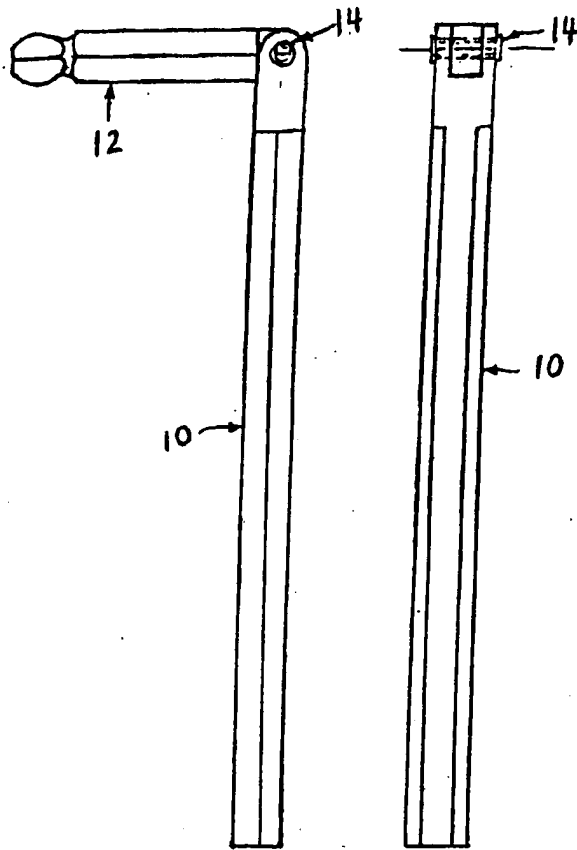
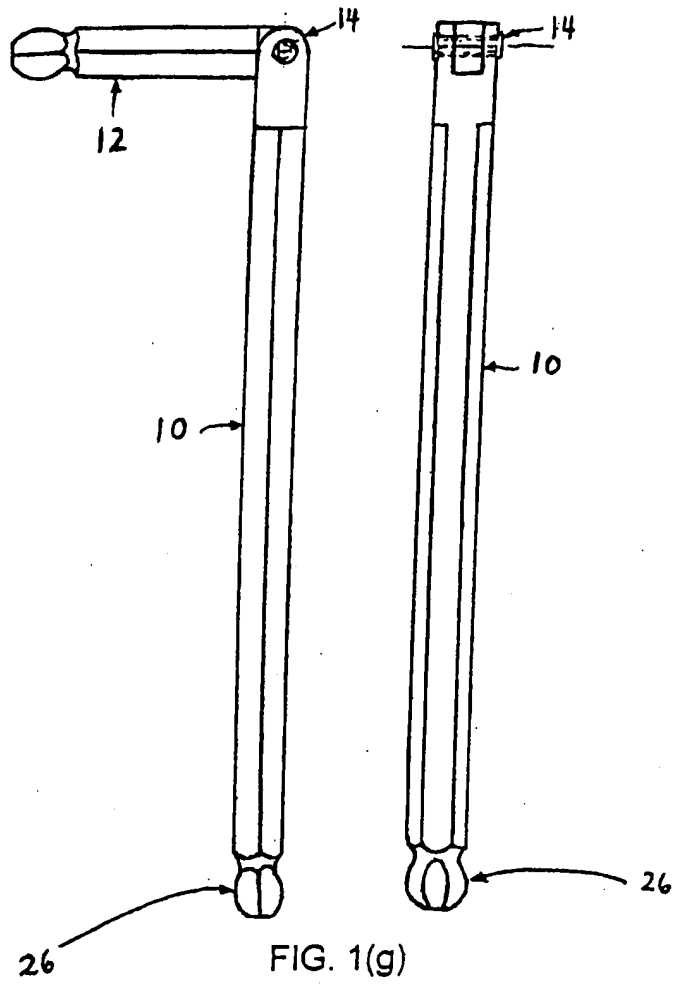
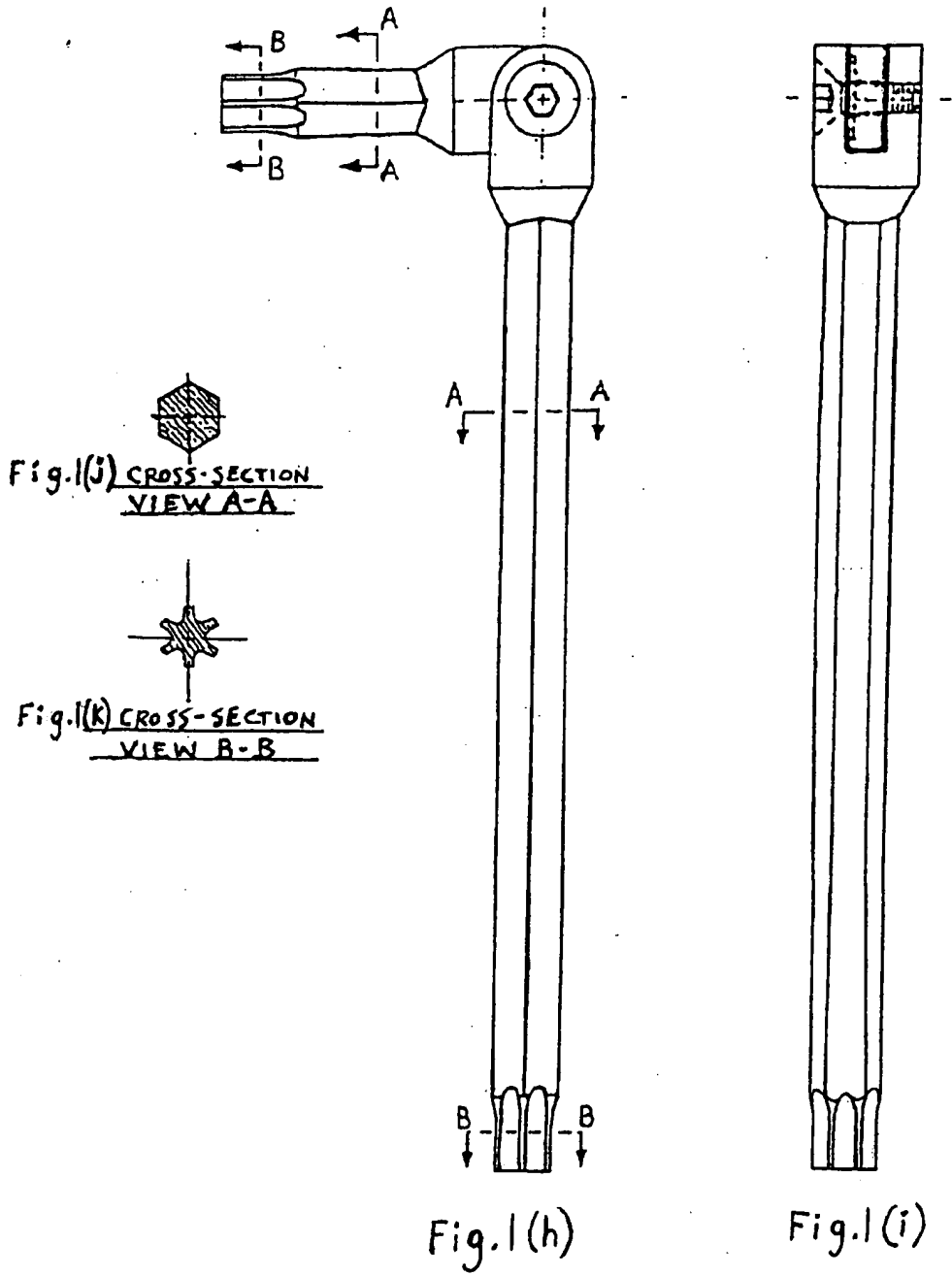

FIG. 1(f)





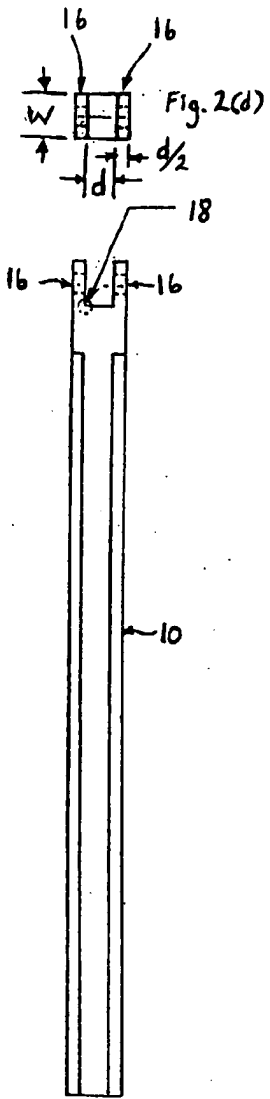

Fig. 2(a)

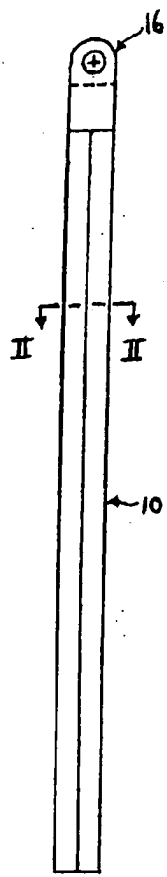

Fig. 2(b)

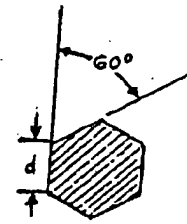
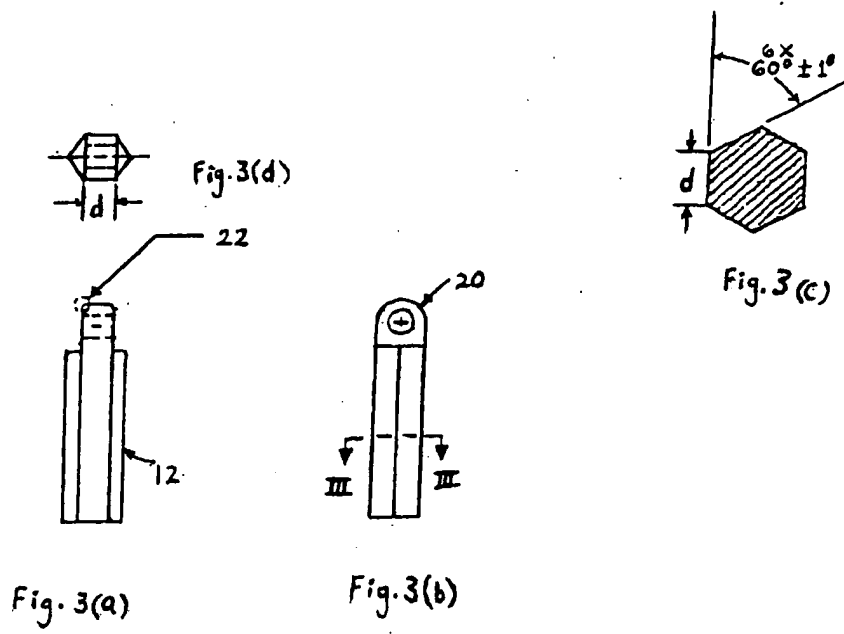

Fig. 2(c)



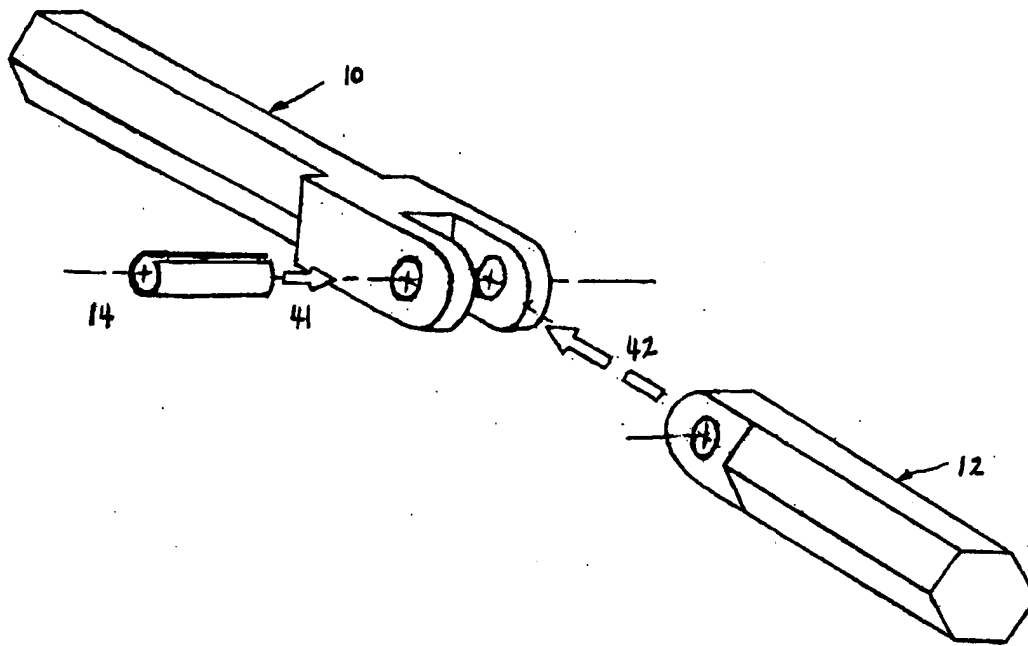
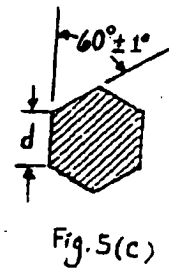
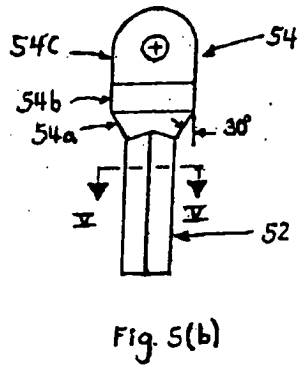
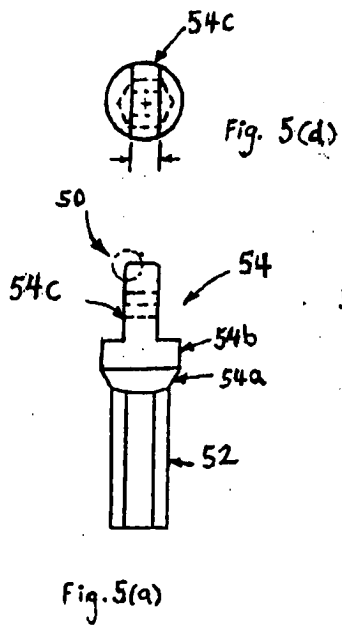
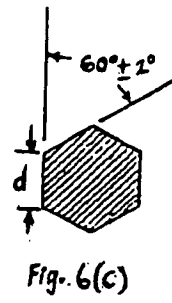
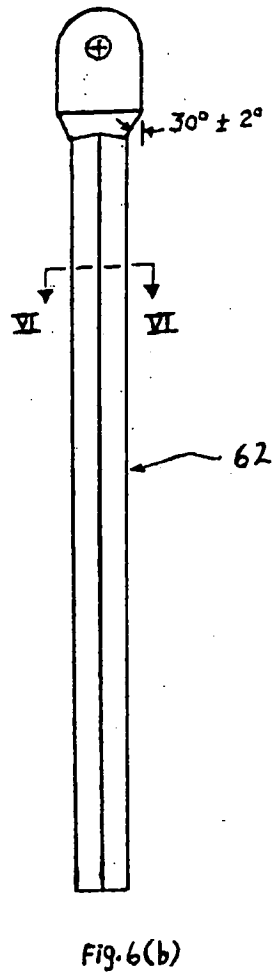
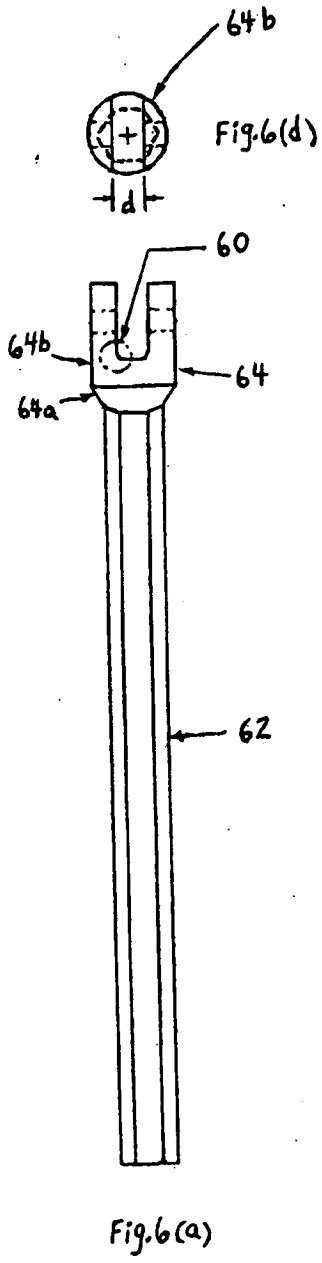

Fig. 4









European Patent  
Office

EUROPEAN SEARCH REPORT

Application Number  
EP 03 01 9992

DOCUMENTS CONSIDERED TO BE RELEVANT			
Category	Citation of document with indication, where appropriate, of relevant passages	Relevant to claim	CLASSIFICATION OF THE APPLICATION (Int.Cl.7)
X	US 2002/108473 A1 (WARNER MARK S) 15 August 2002 (2002-08-15)	1-6	B25G1/06 B25B15/00
Y	* the whole document *	7,8	
X	US 6 443 039 B1 (WARNER MARK S) 3 September 2002 (2002-09-03)	1-6	
Y	* the whole document *	7,8	
Y	WO 90 01399 A (SUNDBERG INGVAR) 22 February 1990 (1990-02-22) * figure 2 *	7,8	
A	US 1 431 389 A (FRISZ GEORGE E) 10 October 1922 (1922-10-10) * figure 3 *	1	
A	CA 1 175 261 A (R T TOOL CO LTD) 2 October 1984 (1984-10-02) * figure 11 *	1	
A	FR 1 027 581 A (PERNIN PHILIPPE) 13 May 1953 (1953-05-13) * figure 3 *	1	
A	US 3 068 728 A (SHEPHERD) 18 December 1962 (1962-12-18) * figure 4 *	1	
The present search report has been drawn up for all claims			
Place of search THE HAGUE		Date of completion of the search 4 February 2004	Examiner Carmichael, Guy
CATEGORY OF CITED DOCUMENTS X : particularly relevant if taken alone Y : particularly relevant if combined with another document of the same category A : technological background O : non-written disclosure P : intermediate document		T : theory or principle underlying the invention E : earlier patent document, but published on, or after the filing date D : document cited in the application L : document cited for other reasons & : member of the same patent family, corresponding document	

1  
EPO FORM 1503 03 82 (P/AC01)

ANNEX TO THE EUROPEAN SEARCH REPORT  
ON EUROPEAN PATENT APPLICATION NO.

EP 03 01 9992

This annex lists the patent family members relating to the patent documents cited in the above-mentioned European search report. The members are as contained in the European Patent Office EDP file on  
The European Patent Office is in no way liable for these particulars which are merely given for the purpose of information.

04-02-2004

Patent document cited in search report	Publication date	Patent family member(s)	Publication date
US 2002108473 A1	15-08-2002	US 6454994 B1 US 6443039 B1 CA 2414538 A1	24-09-2002 03-09-2002 06-10-2003
US 6443039 B1	03-09-2002	US 6314844 B1 US 2002108473 A1	13-11-2001 15-08-2002
WO 9001399 A	22-02-1990	SE 458097 B WO 9001399 A1 EP 0386014 A1 JP 3500391 T SE 8701853 A	27-02-1989 22-02-1990 12-09-1990 31-01-1991 07-11-1988
US 1431389 A	10-10-1922	NONE	
CA 1175261 A	02-10-1984	CA 1175261 A1	02-10-1984
FR 1027581 A	13-05-1953	NONE	
US 3068728 A	18-12-1962	NONE	

EPO FORM P0459

For more details about this annex : see Official Journal of the European Patent Office, No. 12/82