

[54] SNAP-TOP BOTTLE CAP WITH SAFETY PRY-OFF

3,695,476 10/1972 Ruekberg..... 215/225 X

[76] Inventor: Milton Kessler, 6690 Harrington Ave., Youngstown, Ohio 44512

Primary Examiner—George T. Hall
Attorney, Agent, or Firm—Max L. Libman

[22] Filed: June 14, 1973

[21] Appl. No.: 370,016

[57] ABSTRACT

[52] U.S. Cl..... 215/224, 215/206, 215/225, 215/317

To render snap-capped bottles containing dangerous substances safe from children a special unitary force-amplifying structure is provided as part of the plastic cap which cooperates with a special lug on the bottle so that only in one rotary position can the cap be removed and then only by applying a lateral force at a specific area on one side of the cap.

[51] Int. Cl. B65d 55/02, B65d 85/56, A61j 1/00

[58] Field of Search 215/206, 224, 225, 317

[56] References Cited

UNITED STATES PATENTS

3,695,475 10/1972 Ruekberg..... 215/224 X

5 Claims, 4 Drawing Figures

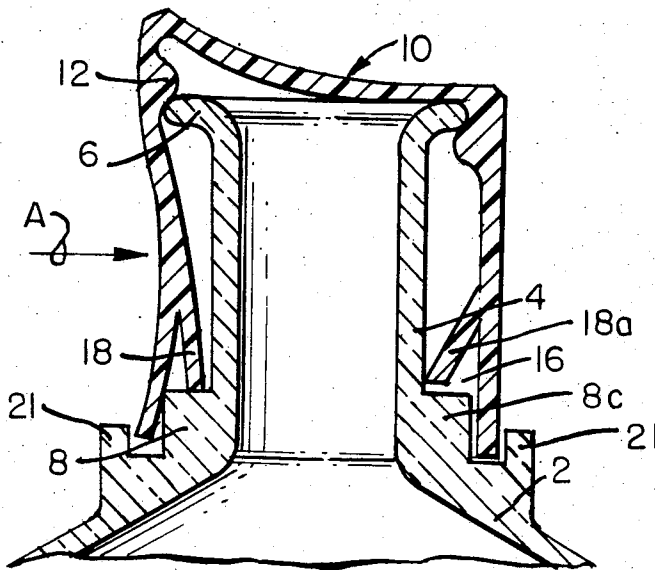

FIG. 1.

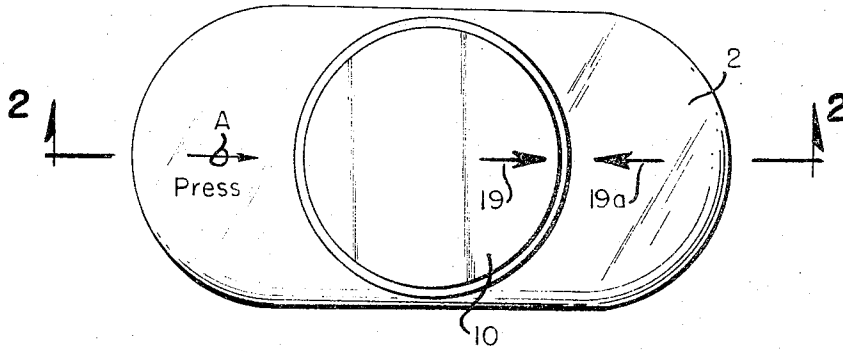

FIG. 2.

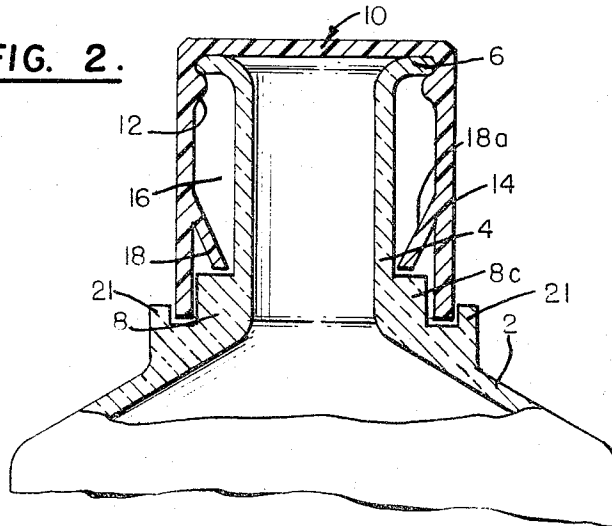

FIG. 3.

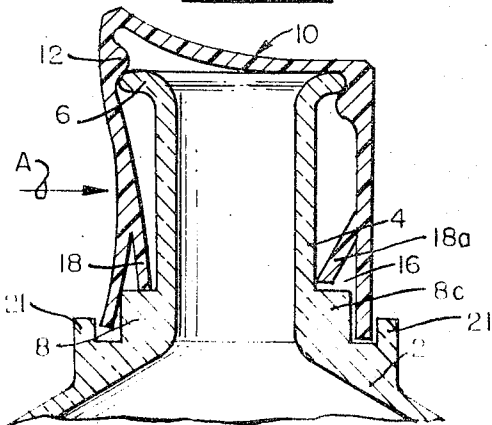
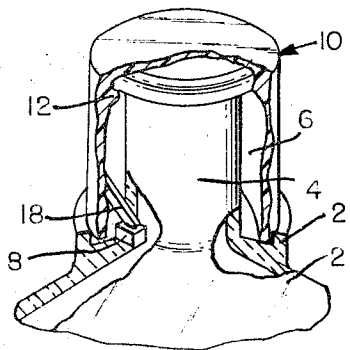

FIG. 4.



SNAP-TOP BOTTLE CAP WITH SAFETY PRY-OFF

Many substances commonly used in the household are dangerous to children, and many harmful and even fatal accidents have been caused by children removing the caps of containers of such substances as asperin, detergents, etc., and taking the contents into their mouth, eyes, etc. The present invention relates to a safety cap which greatly reduces or totally eliminates the danger of such accidents to small children. The invention is applied to a widely-used type of plastic snap-cap having internal flange which fits snugly under an external flange of a pouring spout of the bottle or container, the cap being of semi-rigid material which has only sufficient flexibility so that it can be snapped over the rim of the pouring spout with considerable effort. Once the cap is thus applied, it requires even more effort to remove it, which is usually done by applying force to one side of the cap so as to pry it off of the annular rim of the pouring spout at one point, after which it is easy to remove the entire cap. According to the present invention, it is made even more difficult to remove the cap by simple manual force, since the cap is provided with a downwardly extending cylindrical wall which surrounds the pouring spout, so that it is difficult to pry up one side of the cap by manual pressure alone. In order to remove the cap, an internal pry-bar is provided which cooperates with a special lug on the bottle in only one rotational orientation of the cap, so that when the cap is thus oriented, a lateral pressure on the semi-rigid cylindrical wall of the cap applied at the side where the pry-bar is located will cause the pry-bar to exert sufficient force to pry one side of the cap from the rim of the pouring spout, after which the cap can be easily removed. This operation still requires more force than the average child could apply, and furthermore, as the cap will not normally be in the correct orientation, even if the child could apply sufficient lateral pressure, it will still be ineffective to remove the cap. Instructions are provided on the cap for operating it, but it is assumed that children who are able to read the instructions can be taught that the contents are dangerous.

The specific nature of the invention, as well as other objects and advantages thereof, will clearly appear from a description of a preferred embodiment as shown in the accompanying drawing, in which:

FIG. 1 is a top view of a bottle and cap according to the invention;

FIG. 2 is a view partly in section taken along line 2-2 of FIG. 1 showing the cap in correct orientation;

FIG. 3 is a view similar to FIG. 2, showing the cap immediately after the prying pressure has been applied; and

FIG. 4 is a perspective view partly in section showing the cap in the same condition as in FIG. 2.

The bottle 2 has an integral cylindrical pouring spout 4 provided at its pouring end with an outwardly extending flange 6, and also has extending from the bottle at the bottom of the pouring spout 4 a small lug 8 which is integral with the bottle and made of the same material. A snap cap 10 operates on a well-known and widely-used principle, and has an internal annular flange 12 which engages the underside of the outwardly-extending flange 6 of the pouring spout, and is applied by a downward pressure first on one side of the cap to engage that side with the rim, and then on the other side of the cap to complete the closing engagement, as

is well known. The customary snap-cap, however has an outwardly extending annular flange so that it can be removed in a reverse manner by finger pressure applied to said flange. However, the present invention does not have such a flange, but instead has a straight downwardly extending skirt or wall 14 surrounding the cylindrical spout 4, and of sufficiently larger diameter than the pouring spout so that a considerable annular gap or space 16 exists between the cap and spout. A semi-rigid bar 18 extends diagonally downward from the wall of the pouring spout from a point above the lug toward the lug but stops short of making contact with the lug in the normal condition of the cap as shown in FIG. 2. Since the bar 18 and lug 8 are made of the same circumferential extent, normally in the order of 1/4 inch for most sizes of bottles, it is apparent that ordinarily the two elements will not be in registry as shown in FIG. 2, but will have different orientations. Instructions are therefore provided on the top of the cap as shown in FIG. 1, so that the user who wishes to remove the cap will rotate the cap into the position of FIG. 1, where the two arrows 19, 19a shown, one on the bottle and one on the cap, are in registry, which means that the bar 18 and lug 8 are also in registry, as they will now have the same rotary orientation. In this condition, if lateral pressure is applied to the side of the cap as indicated by the arrow A in FIGS. 1 and 3, the bar 18 in conjunction with the semi-rigid cylindrical wall 14 of the cap provide a force-amplifying mechanism to pry the top of the cap 10 away from the annular flange 6 as shown in FIG. 3, after which the cap can be readily removed by simply pulling it away from the spout.

If desired, a second bar 18a and lug 8c can be provided on the opposite side of the cap, to insure that the whole cap will snap off when pressure is applied to the two sides containing the lugs.

A recessed annular ledge 21 is preferably provided to receive the lower edge of the cap 12, to prevent the cap from being pried off by a fingernail or a knife thrust under the edge.

The cap normally makes a fairly snug friction fit with the top of the bottle; it requires considerable force to rotate it into the correct position, which would be beyond the power of the average child, in fact, it may be desirable to narrow or otherwise roughen the outer side of the cylindrical wall of the cap in order to make it possible for even an adult to rotate the cap into the correct position. After this position is attained, it still requires more force than the average child could provide to remove the cap, even if it should happen to be oriented. However, in the vast majority of cases, the cap will not be correctly oriented, even by chance, and users of the cap can also be warned by suitable notice on or provided with the bottle to make sure that the orientation when the cap is normally closed is such that the bar 18 and lug 8 are not in engagement. It is thus apparent that in normal use of the cap the chances of its being opened by a small child become vanishingly small.

I claim:

1. Safety means for containers comprising in combination

a. a container having a cylindrical pouring spout with a thin annular outwardly-extending flange at the top of the spout,

b. and a plastic snap-cap snugly fitting the top of said spout, said cap having an internal annular flange

3

elastically engaging the underside of said outwardly-extending flange to retain said cap on the spout,

- c. said cap having a downwardly-extending semi-rigid cylindrical wall surrounding said cylindrical pouring spout and of sufficiently greater diameter than the outer diameter of said spout to provide a substantial cylindrical gap between said wall and said spout,
- d. a small lug in said gap extending at the base of said cylindrical spout toward said cylindrical wall of the cap and fixed to said container,
- e. a semi-rigid bar of the same plastic material as the cap and unitary therewith extending diagonally downward from a point above said lug toward said lug but not as far as the lug, even when the cap is rotated so that the lug and bar have the same orientation, said bar being sufficiently stiff so that when the cap is rotated to have the same orientation as the lug and the side of the cap containing the bar

4

is pressed toward the spout, the end of the bar will engage the lug and pry at least a portion of the snap cap off the annular flange so that the cap can then be readily removed from the spout.

2. The invention according to claim 1, and indicia on the cap and on the bottle for indicating when the lug and bar have the same rotary orientation.

3. The invention according to claim 2, said cap being of opaque material, said cylindrical wall of the cap extending downward sufficiently far to cover said lug so that it is not visible when the cap is in place.

4. The invention according to claim 3, and a second bar and lug similar to said first semi-rigid bar and first lug and on the opposite inner side of the cap from said first bar and lug.

5. The invention according to claim 4, and an annular recessed ledge on said container for receiving the bottom edge of said cap.

* * * * *

25
30
35
40
45
50
55
60
65