



US00D386405S

United States Patent [19]

[11] Patent Number: Des. 386,405

Bernstein et al.

[45] Date of Patent: **Nov. 18, 1997

[54] MOTOR VEHICLE TUNE-UP KIT
CONTAINER

5,044,495 9/1991 Wyslotsky 206/461 X
5,209,354 5/1993 Thornhill et al. 206/461 X

[75] Inventors: I. Robert Bernstein, Deerfield; Joseph
W. Gaske, Brookfield; Daniel J. Flynn,
DesPlaines, all of Ill.

OTHER PUBLICATIONS

Modern Packaging, 1941, p. 300.

[73] Assignee: Triple-A Specialty Co., Chicago, Ill.

Primary Examiner—Prabhakar G. Deshmukh

Attorney, Agent, or Firm—Gerstman, Ellis & McMillin, Ltd.

[**] Term: 14 Years

[57] CLAIM

The ornamental design for a motor vehicle tune-up kit container, as shown and described.

[21] Appl. No.: 63,581

[22] Filed: Dec. 4, 1996

DESCRIPTION

[51] LOC (6) CL 09-07

[52] U.S. Cl. D9/415

[58] Field of Search D9/415, 418, 414,
D9/341, 347; 206/461-471, 495, 769, 770,
771, 773, 223, 319, 806

FIG. 1 is a perspective view of the motor vehicle tune-up kit container showing our new design;

FIG. 2 is a right side view thereof, with the left side view being the mirror image thereof;

FIG. 3 is a top view thereof;

FIG. 4 is a front view thereof;

FIG. 5 is a rear view thereof;

FIG. 6 is a bottom view thereof;

FIG. 7 is a top view of a second embodiment of the invention; and,

FIG. 8 is a front view of the second embodiment of the invention.

[56] References Cited

U.S. PATENT DOCUMENTS

D. 292,776 11/1987 Cugley D9/415
D. 310,462 9/1990 Schoen D9/415 X
D. 327,844 7/1992 Wimbish et al. D9/415
D. 350,693 9/1994 Pratt D9/415
4,781,289 11/1988 Perkins 206/461 X

1 Claim, 4 Drawing Sheets

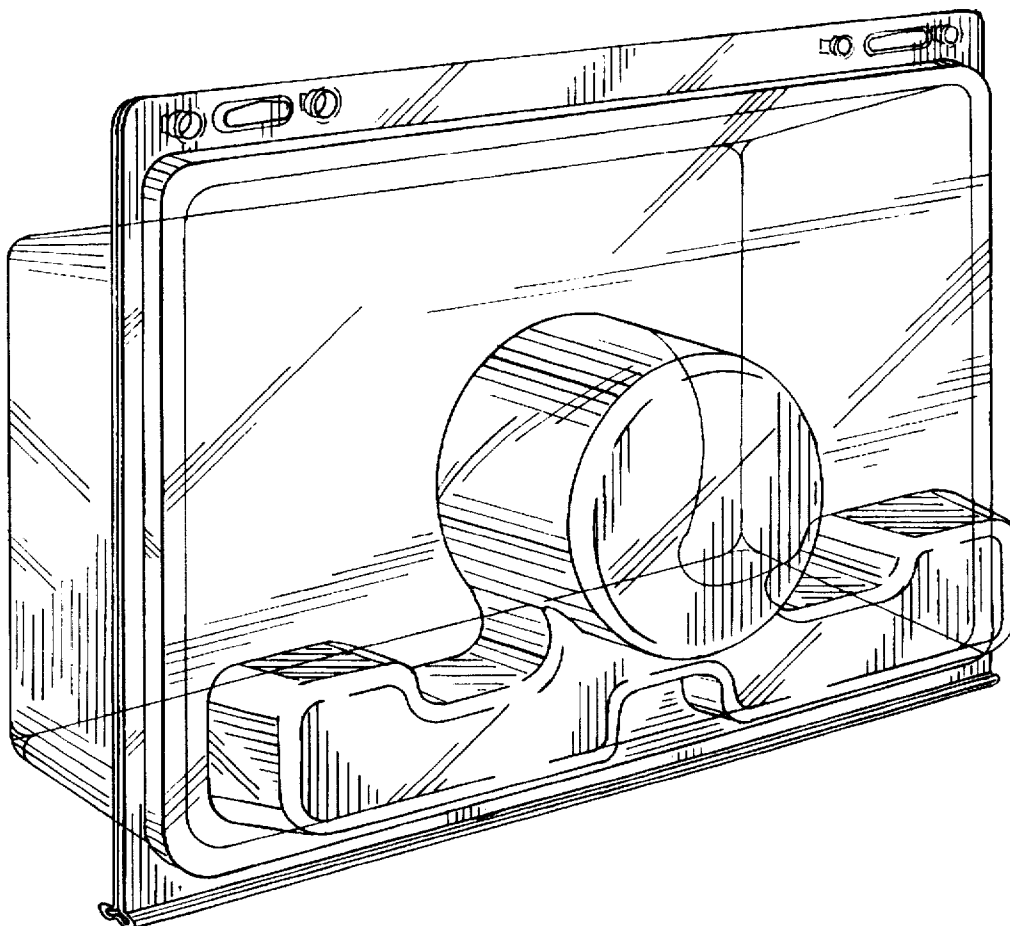

FIG. 1

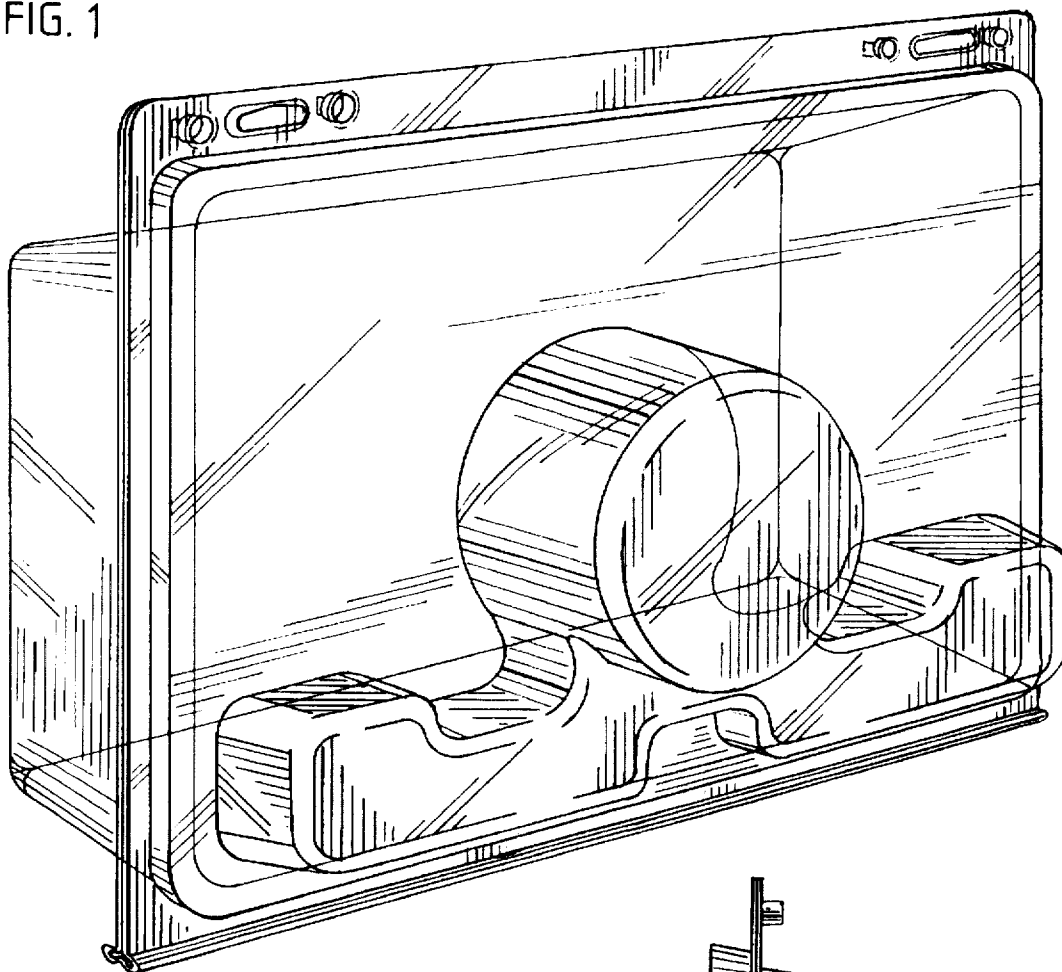

FIG. 2

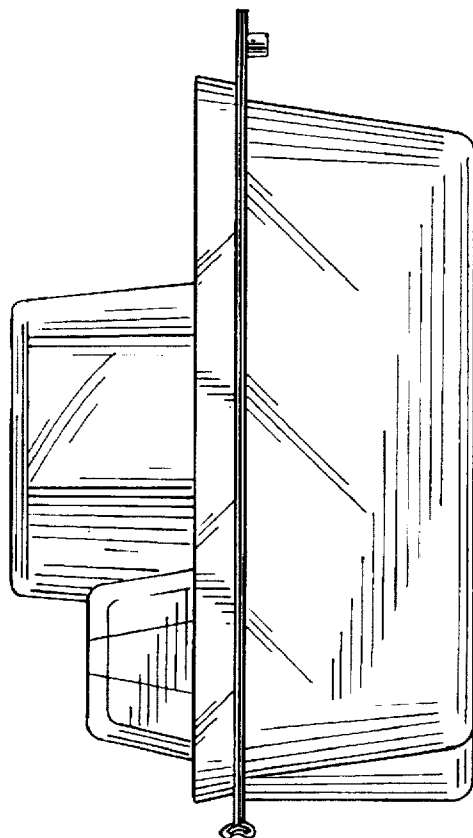

FIG. 3

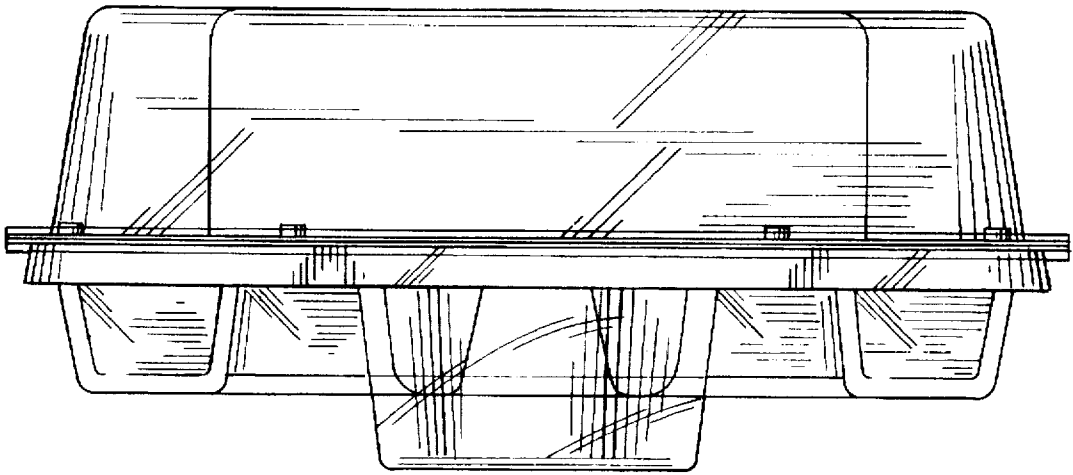

FIG. 4

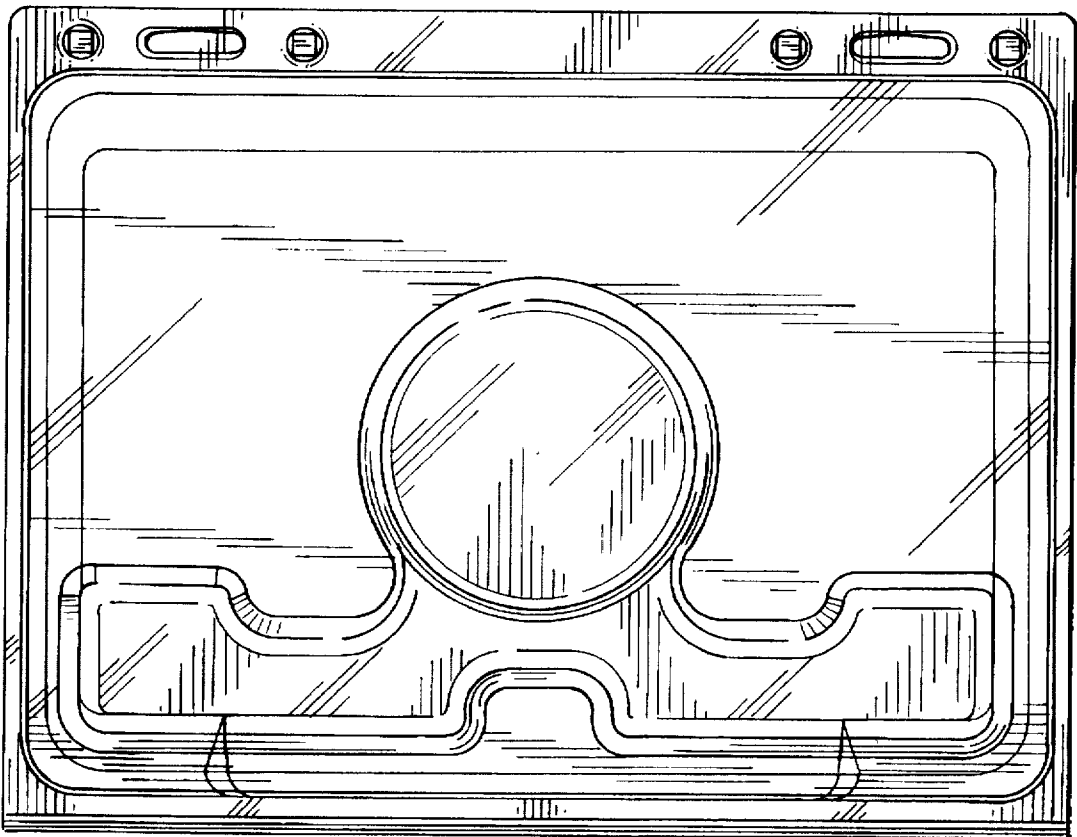

FIG. 5

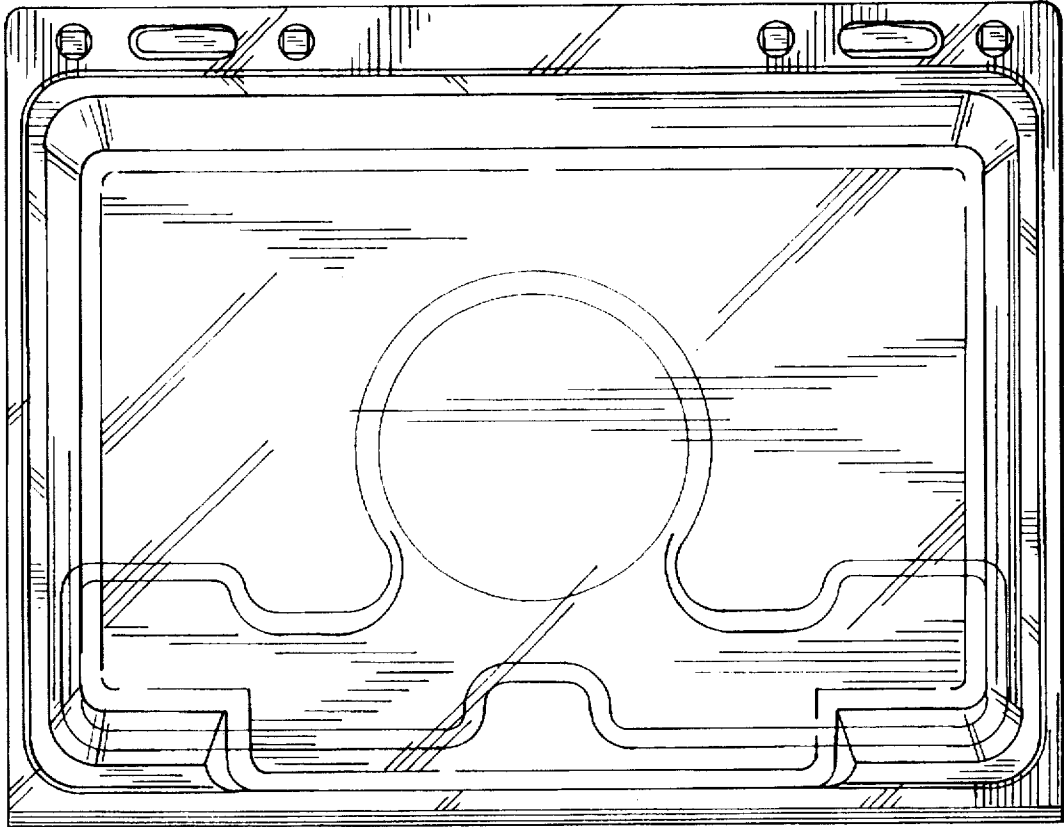

FIG. 6

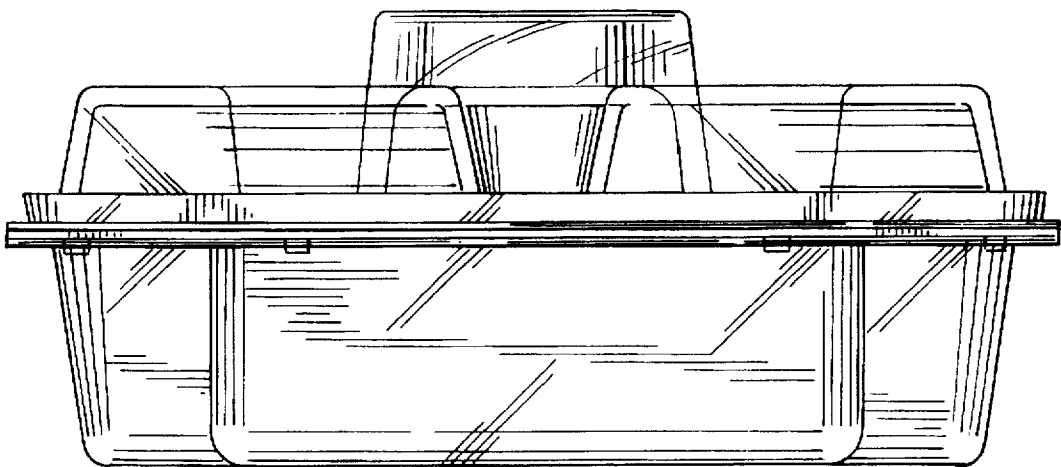

FIG. 7

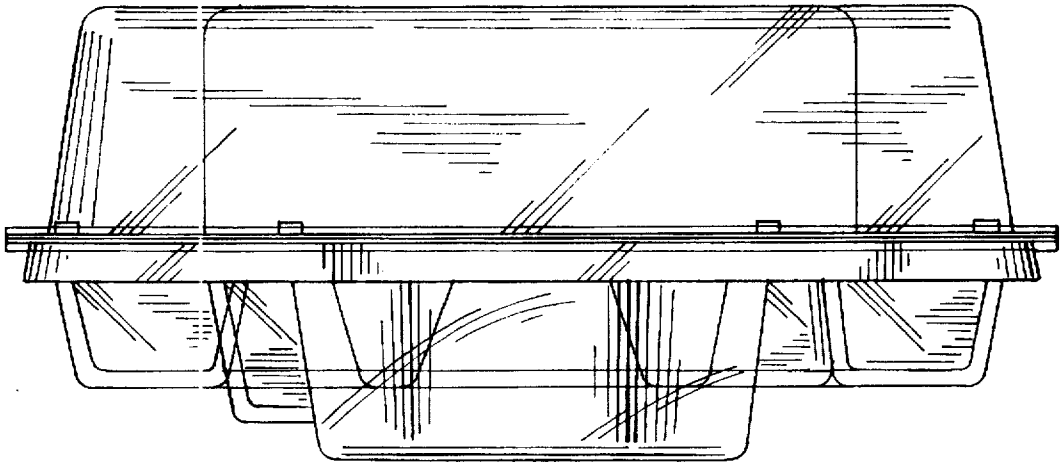

FIG. 8

