

(21) Application No 8808189  
(22) Date of filing 8 Apr 1988  
(30) Priority data  
(31) 8710129 (32) 29 Apr 1987 (33) GB

(71) Applicant  
**Rhombus Tools Limited**  
  
(Incorporated in United Kingdom)  
  
Unit 23, Forge Trading Estate, Mucklow Hill,  
Halesowen, West Midlands, B62 8TP

(72) Inventor  
Laurence John Potter

(74) Agent and/or Address for Service  
Marks & Clerk  
Alpha Tower, Suffolk Street, Queensway,  
Birmingham, B1 1TT

(51) INT CL<sup>4</sup>  
B25B 5/06

(52) Domestic classification (Edition J):  
B4W 3C 3K1 3K3

(56) Documents cited  
GB 1544156 GB 1472278

(58) Field of search  
B4W  
Selected US specifications from IPC sub-class  
B25B

(54) A sliding jaw clamp

(57) A clamp comprises a spine (11), a movable arm (10, 103) slidably mounted on the spine, a jaw (13) provided on the movable arm, a slide member (30) mounted on the spine, an operating handle (28) pivotally mounted on the movable arm (10), a link (34) pivotally connected to both the handle and the slide member, and biasing means (35) effective between the handle on the movable arm and the slide member, operation of the handle, in use, causing the slide member (30) to grip the spine (11) whilst displacing the movable arm, so as to allow operation of the clamp by only one hand.

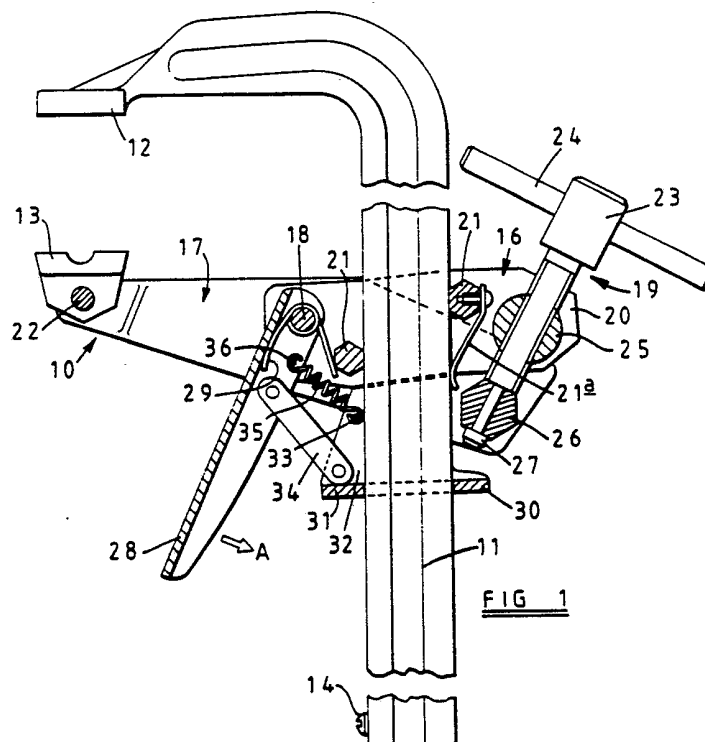

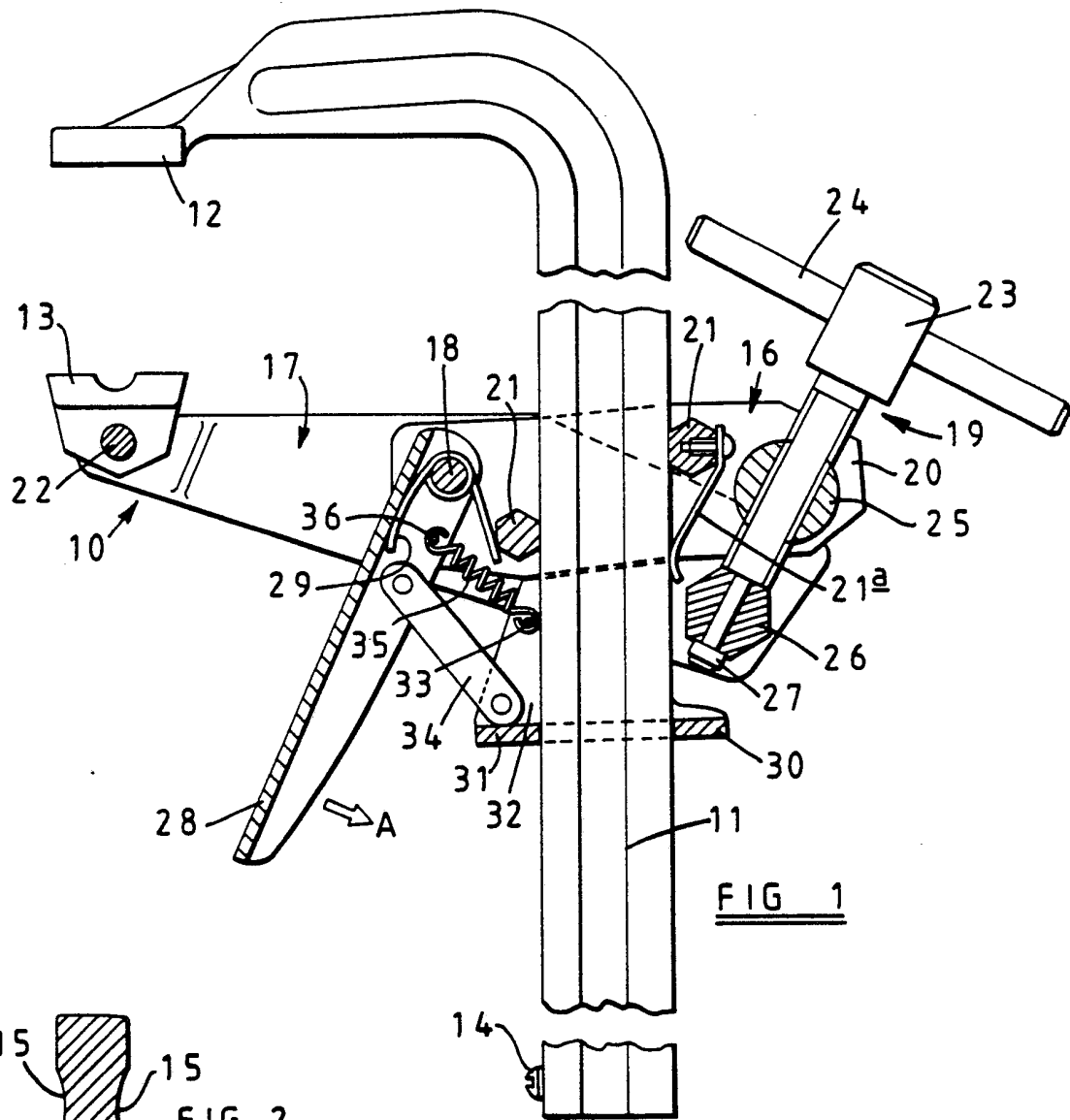

FIG 1

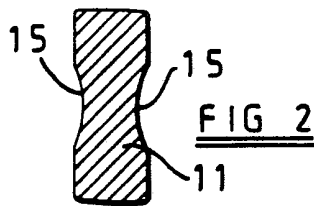

FIG 2

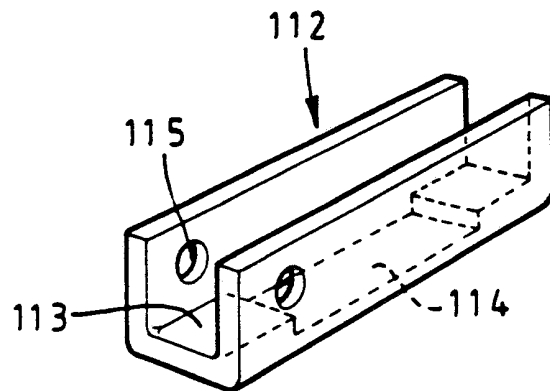

FIG 4

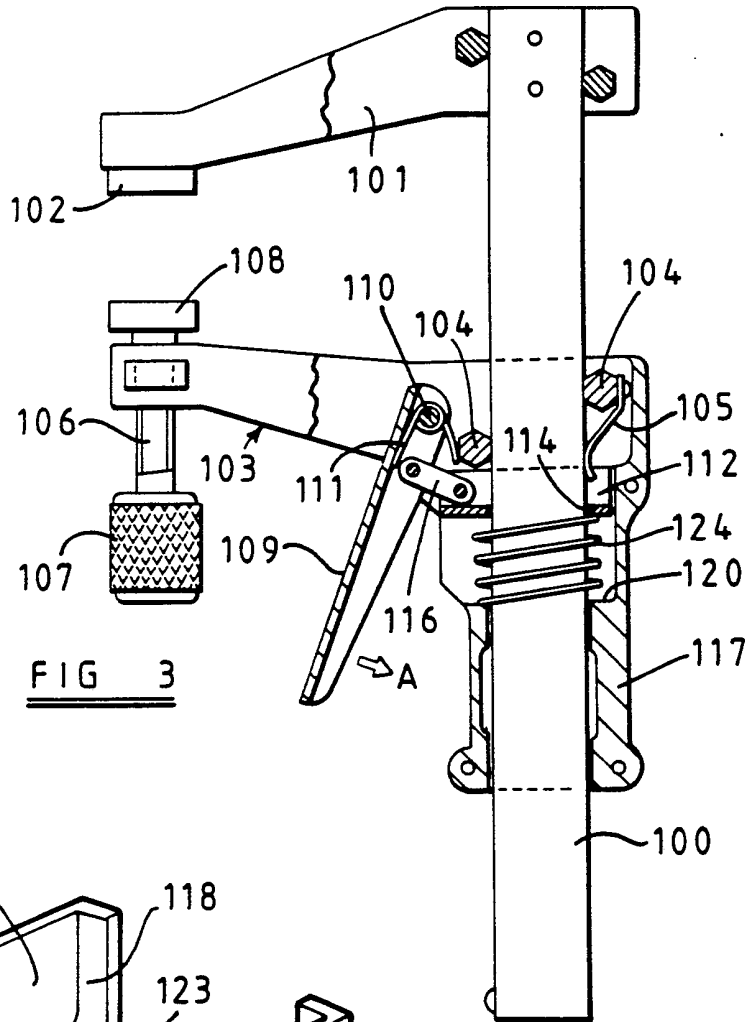

FIG 3

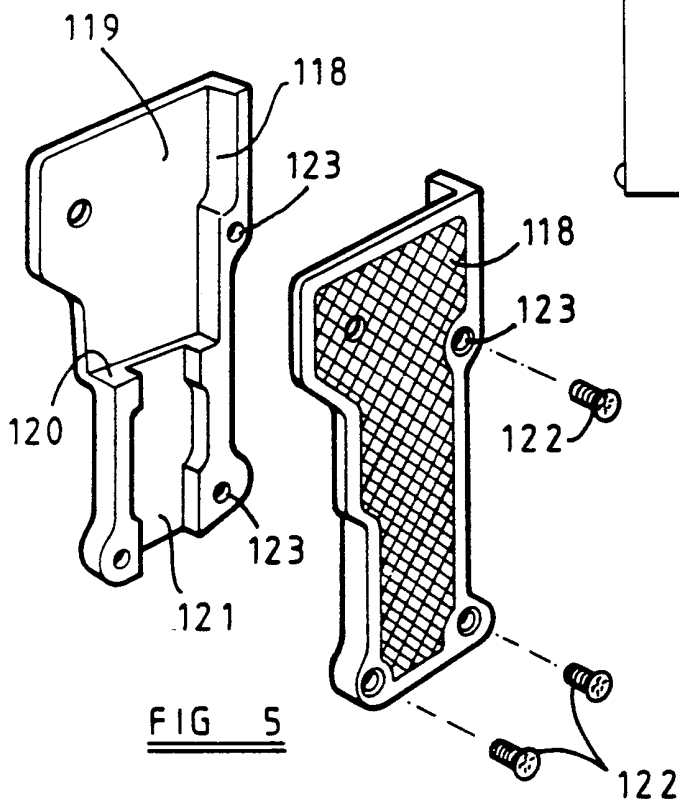

FIG 5

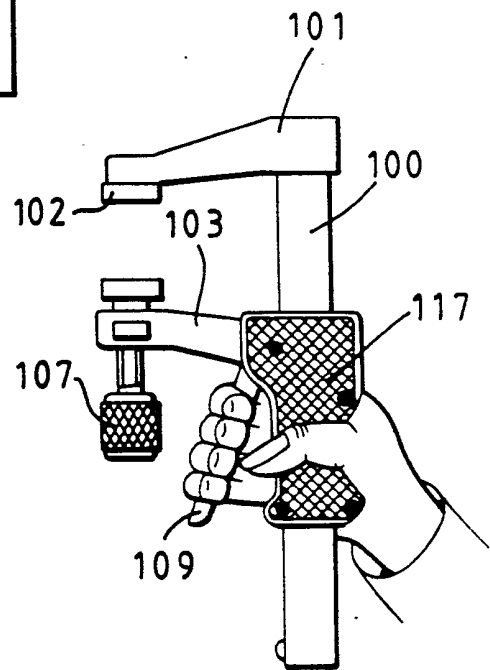

FIG 6

A CLAMP

This invention relates to a clamp and is particularly concerned with a clamp of the type which comprises a movable arm provided with a jaw and mounted on a spine. Usually, with clamps of this type, a fixed jaw is provided on the spine.

In prior art clamps of this type, when engaging the clamp with a workpiece it is necessary to hold the spine with one hand and to move the movable arm with the other hand until the movable jaw engages the workpiece. An adjustment is then made to bring the movable jaw into tight engagement with the workpiece. It is sometimes necessary to hold the workpiece in position whilst engaging the clamp but it is difficult for an unassisted person to do this whilst also operating the clamp.

It is an object of this invention to provide a new clamp in which the movable arm can be moved along the spine whilst operating the clamp with only one hand.

According to the invention, there is provided a clamp comprising a spine, a movable arm slidably mounted on the spine, and a jaw provided on the movable arm, wherein there is a slide member mounted on the spine, and an operating device arranged to cause the slide member to grip the spine whilst displacing the movable arm.

With a clamp of the invention, with the aid of the operating device the movable arm can be made to progress along the spine using only one hand and thereby leaving the other hand free to hold the workpiece.

Conveniently the operating device comprises a handle pivotally mounted on the arm and a link pivotally connected to both the handle and the slide member.

In one arrangement, the slide member is provided with a pin for engaging an edge of the spine.

In another arrangement, there is provided a housing for the slide member, said housing being slidably mounted on the spine and having a spring for biasing the slide member into engagement with two opposite edges of the spine. The housing may be arranged to move with the movable arm and may form, with the handle a hand grip arrangement.

The movable arm may be provided with a pair of friction pads for gripping the spine.

The clamp may include means for displacing the jaw which is provided on the movable arm relative to at least part of the movable arm in order to grip a workpiece.

The spine may be provided with a fixed jaw or alternatively the spine may be provided with a second movable arm.

The invention will now be described, by way of example, with reference to the accompanying drawings, in which:

Figure 1 is a part-sectional plan view of a first clamp embodying this invention;

Figure 2 shows a cross section of a spine of the clamp of Figure 1;

Figure 3 is a part-sectional plan view of another clamp embodying the invention;

Figure 4 is a perspective view of a slide member of the clamp of Figure 3;

Figure 5 is an exploded perspective view of a housing of the clamp of Figure 3, and

Figure 6 shows how the clamp of Figure 3 can be gripped for operation, in use.

Referring now to Figure 1, the clamp comprises a movable arm 10 mounted on a spine 11. One end of the spine 11 is bent and terminates with a fixed jaw 12. The movable arm carries a movable jaw 13 which faces the fixed jaw 12. A screw 14 engages the other end of spine 11 in order to prevent the arm 10 from being accidentally disengaged from spine 11.

As shown in Figure 2, the spine 11 is provided with a pair of curved recesses 15 which result in the spine 11 having a strong but lightweight construction.

The movable arm comprises a first member 16 slidably mounted on spine 11, a second member 17 pivotally mounted by a rivet 18 to the first member 16, and a screw assembly 19 for rotating the second member 17 relative to the first member 16. The first member 16 comprises a pair of plates, one of which is shown at 20, the plates being located on opposite sides of the spine 11. The first member also comprises a pair of friction pads 21, shown in Figure 1. A spring 21a, is secured to one of the friction pads and engages an edge of the spine 11. This spring functions to keep the pads 21 in firm engagement with the spine 11, with the movable jaw 13 being biased towards fixed jaw 12.

The second member 17 also comprises a pair of plates and these are held together at one end by a rivet 22 which passes through the movable jaw 13.

The screw assembly 19 comprises a screw member 23 having a cross bar 24. The shank of screw member 23 has a threaded section which engages the internal screw thread of a nut 25 mounted on the first member 16. An unthreaded end part of the shank of the screw member 23 is held in a reaction member 26 secured to the second member 17 by a nut 27 on the end of the unthreaded part.

The clamp further comprises a handle 28 of generally "U" shaped cross section which is pivotally connected to the rivet 18. A leaf spring 29 which is bent over rivet 18 is arranged with one end engaging one of the friction pads 21 and its other end engaging an inner surface of the lever 28. The spring 29 biases the lever 28 in a clockwise direction as viewed in Figure 1. A slide member 30 is slidably mounted on the spine 11. The slide member is U-shaped having a base part 31 and integral, spaced parallel limbs 32 normal to the base. The base 31 has a rectangular aperture therein of a complementary cross-section to the rectangular outline of the spine 11 and the two limbs 32 of the slide member 30 are provided with respective circular holes. Between the limbs 32 is provided a pin 33 which can engage against one edge of spine 11. A link 34 is pivotally connected between the handle 28 and the circular holes of the slide member 30. The respective upper surfaces of the limbs 32 are shaped to engage respective complementarily shaped parts of the lower surfaces of the plates 20 of the first member 16. An extension spring 35 extends from the pin 33 to a pin 36 on the handle 28 to bias the slide member in an anticlockwise direction as viewed in Figure 1.

In use, the clamp is located so that the fixed jaw 12 loosely engages one surface of a workpiece. The handle 28 is closed by moving it in the direction

indicated by arrow A. During initial movement of the handle 28, the action of the link 34 and spring 35 causes the slide member 30 to rotate slightly anticlockwise, so as to grip the spine 11. During the remainder of this movement of the handle 28, the movable arm 10 is pushed upwardly through the action of the link 34, and the spring 35 is thus extended.

If the handle 28 is then released, it will return to its position, shown in Figure 1, under the action of the spring 29. As it returns, the link 34 pulls the slide member 30 upwardly on the spine towards the movable arm 10. During this return movement, the slide 30 is prevented from gripping spine 11 by the pin 33. The handle 28 can thus be operated repeatedly as described until both jaws 12, 13 engage the workpiece.

The screw member 23 is then operated thereby causing the second member 17 to pivot clockwise relative to the first member 16. The screw member 23 is rotated until the jaws 12, 13 engage the workpiece with the desired gripping force.

In order to disengage the clamp from the workpiece, the screw member 23 is rotated in the opposite direction to remove the gripping force. The movable arm 10 can then be pushed downwardly on the spine away from fixed jaw 12. During such movement, the lower surfaces of the plates 20 engage the respective complementarily shaped upper surfaces of the slide member 30 thereby ensuring that the slide member is normal to the spine so that it moves easily together with the movable arm 10.

As may be appreciated, the provision of the handle 28, slide member 30 and link 32 makes it



possible to operate the clamp with one hand thereby leaving the other hand free to hold the workpiece.

Referring now to Figure 3, there is shown a clamp comprising a spine 100 having a fixed arm 101 provided with a fixed jaw 102. A movable arm 103 is slidably mounted on the spine 100. As with the embodiment of Figure 1, the movable arm 103 is provided with a pair of friction pads 104 for engaging the spine 100, together with a spring 105 which keeps the friction pads in engagement with the spine.

The end of movable arm 103 remote from spine 100 has a threaded aperture which receives a threaded spindle 106. One end of spindle 106 is mounted in a handle 107 and the other end is secured to a jaw 108.

A handle 109, similar to the handle 28 of Figure 1, is pivotally mounted on the arm 103 by a pivot pin 110. A leaf spring 111 biases handle 109 in a clockwise direction.

A slide member 112 is slidably mounted on the spine 100. As shown in Figure 4 the slide member 112 is U-shaped having in its base 113 a rectangular aperture 114 that can engage the spine 100 passing therethrough, and having in its opposite limbs respective circular apertures 115. A link 116 is pivotally connected between the handle 109 and the apertures 115 of the slide member 112.

The slide member 112 is provided with a housing 117, which is shown in more detail in Figure 5. The housing is formed of two identical, but oppositely handed moulding halves 118, each having an upper inner recess 119 adapted to receive a part of the arm 103

which is on the spine, as shown in Figure 1. A middle part of the recess receives the slide member 112, whilst there is a shoulder 120 between the recess 119 and a less deep recess 121 extending to the lower end of the moulding half for receiving the spine. The halves are connected together by screws 122 in holes 123 in the mouldings. Further respective aligned holes in the two halves receive a rivet passing through the arm 103 to connect the housing to the arm. A compression spring 124 is arranged between the shoulder 120 and the underside of the base 113 of the slide member and functions to bias the slide member in an anticlockwise direction, as viewed in Figure 3. As can be seen from Figure 3, the upper edges of the slide member 112 engage the underneath surface of the arm 103 when the handle 109 is in its open position.

In use, the clamp is positioned so that the fixed jaw 102 lightly engages the workpiece. The handle 109 is then closed by moving it in the direction indicated by arrow A. In a similar manner to that already described with reference to Figure 1, this initially causes the slide member 112 to rotate slightly to grip the spine 100 so that the movable arm 103 is displaced towards the fixed jaw 102. During this upward movement of the arm 103, the housing 117, which is connected with the arm 103, moves together with arm 103, so that the slide member is effectively displaced to the bottom of the recess 119 in each half 118 as the housing slides relative to the stationary member 112.

When the handle 109 is released, the biasing action of the spring 124 ensures that the slide member 112 is released from its gripping engagement with the spine 100, with the result that the slide member 110 moves upwardly towards the arm 103.

The handle 107 can thus be repeatedly operated in this manner until both jaws 102, 108 engage a workpiece. The handle 107 is then rotated so as to achieve desired gripping force. Figure 6 shows how the clamp housing 117 and handle are gripped by an operator's hand so as to constitute a hand grip arrangement.

In order to release a workpiece, the handle 107 is rotated in the opposite direction. The movable arm 103 may then be pushed downwardly away from the fixed jaw 102. During this movement, the arm 103 bears on the respective upper surfaces of the limbs of the slide member 112 and thus the movable arm, the slide member and the housing 117 move downwardly without gripping the spine 100.

In the examples shown in Figures 1 to 6, it is possible to achieve a very high gripping force on a workpiece. Where it is not necessary to achieve such a gripping force, a simpler arrangement may be adopted. For example, referring to Figure 3, the jaw 108 could be attached rigidly to the arm 103 and a screw could be provided on the arm 103 for engaging the side of the spine 100. With such an arrangement, the handle 109 would be operated until the jaws 102, 106 engage a workpiece and the screw would then be rotated to grip the side of spine 100 so as to hold the movable arm 103 in position. Also, by making the movable arm 103 a snug fit on the spine 100, it would be possible to omit the friction pads.

In the clamp of either Figure 1 or the clamp of Figure 3, the spine together with a fixed jaw could be replaced by a straight spine on which there are mounted two movable arms, each provided with a jaw.

In a modification to the arrangement shown in Figure 3, the aperture 114 is slightly enlarged lengthways and the base 113 of the slide member 112 adjacent the link 116 has a screw threaded hole therein. A headed screw is engaged in the hole, with its shank and head extending downwardly from the underside of the base 113, with the head being accessible from outside of the housing 117. The screw shank passes with significant clearance through a hole in one limb of a hardened and tempered L-shaped member, said one limb being normal to the shank and forced against the underside of the screw head by a coil spring around the screw shank and acting between the underside of the base 113 and said one limb. The other limb of the L-shaped member bears against the side of the spine, this limb decreasing in thickness away from its junction with said one limb, so as to form a wedge, which projects into the slightly enlarged aperture 114. Thus by adjustment of the screw during initial production of the clamp, the correct critical relationship between the dimensions of the aperture 114 and spine 100 can be set, the thickness of the part of the wedge within the aperture 114 acting as part of the spine and overcoming any tolerance problem with production of the required spine width. Additionally should any component wear occur during the life of the clamp to affect the grip of the slide member on the spine, a user can adjust the screw to compensate accordingly, with a thicker part of the wedge being moved into the aperture. Instead of the spring 124 around the spine, a spring at its right hand side only may be used with either the Figure 3 or modified Figure 3 arrangement described. Moreover this adjustment arrangement described can equally be applied to the clamp of Figure 1. For any of the embodiments, an insert, effectively acting as part of the spine, could also be provided on the right hand end of the aperture should the wedge adjustment be provided.

8. A clamp as claimed in any one of the preceding claims, wherein the spine has a fixed jaw at one of its ends.

9. A clamp as claimed in any one of the preceding claims, wherein the slide member carries a pin for engaging the spine when the operating device is released.

10. A clamp as claimed in claim 9, wherein an extension spring has one end connected to said pin and its other end connected to the operating device to bias it away from the spine.

11. A clamp as claimed in any one of the preceding claims, wherein screw means are provided on the movable arm for displacing the jaw thereon relative to at least part of the movable arm in order to move the jaw, in use, towards or away from a workpiece.

12. A clamp as claimed in any one of claims 1 to 8, wherein the slide member is received in a recess defined in a housing slidably mounted on the spine.

13. A clamp as claimed in claim 12, wherein the housing is connected to the movable arm so as to move therewith as said arm is displaced, in use.

14. A clamp as claimed in claim 13, wherein a compression spring is disposed in said recess in the housing, one end of the spring engaging a shoulder at one end of the recess, and the other end engaging the slide member to bias it towards the movable arm.

CLAIMS

1. A clamp comprising a spine, a movable arm slidably mounted on the spine, and a jaw provided on the movable arm, wherein there is a slide member mounted on the spine, and an operating device arranged to cause the slide member to grip the spine whilst displacing the movable arm.

2. A clamp as claimed in claim 1, wherein the operating device comprises a handle pivotally mounted on the movable arm, and a link pivotally connected to both the handle and the slide member.

3. A clamp as claimed in claim 1 or claim 2, wherein biasing means is effective between the handle on the movable arm and the slide member.

4. A clamp as claimed in any one of claims 1 to 3, wherein the movable arm has a pair of friction pads for oppositely gripping the spine, the pads being biased into such gripping engagement.

5. A clamp as claimed in any one of the preceding claims, wherein the handle is biased in a direction away from the spine.

6. A clamp as claimed in any one of the preceding claims, wherein the slide member is of U-shape in cross-section, the spine extending through an aperture in a base which is generally complementary to the outline of the spine.

7. A clamp as claimed in claim 6, wherein upper surfaces of the slide member are of complementary shape to the facing lower surfaces of the movable arm.

15. A clamp as claimed in any one of claims 1 to 8, or claims 12 to 14, wherein the movable arm has a threaded aperture in its end remote from the spine, the aperture receiving a threaded spindle, to one end of which is mounted a handle and to the other end of which is secured a jaw.

16. A clamp as claimed in any one of the preceding claims, wherein the slide member carries a wedge element which bears against the spine and against which the slide member engages when the operating device is operated to displace the movable arm.

17. A clamp as claimed in claim 16, wherein the wedge element is adjustable at least towards the slide member so that said engagement of the slide member with the wedge element is against a thicker part thereof.

18. A clamp as claimed in claim 17, wherein the adjustment of the wedge element is by means of a headed screw engaged with the slide member, the wedge member being held in an adjusted position by the force of a spring.

19. A clamp substantially as hereinbefore described with reference to and as shown in the accompanying drawings.