



(11) **EP 1 761 155 B1**

(12) **EUROPEAN PATENT SPECIFICATION**

(45) Date of publication and mention of the grant of the patent:
23.09.2009 Bulletin 2009/39

(21) Application number: **04740408.2**

(22) Date of filing: **29.06.2004**

(51) Int Cl.:
A47L 13/20^(2006.01) B25G 1/04^(2006.01)

(86) International application number:
PCT/EP2004/007012

(87) International publication number:
WO 2006/002655 (12.01.2006 Gazette 2006/02)

(54) **MOP HANDLE FOR A MOPPING DEVICE**

MOPPGRIF FÜR EINE MOPPVORRICHTUNG

MANCHE DE BALAI POUR DISPOSITIF DE LAVAGE DU SOL

(84) Designated Contracting States:
AT BE BG CH CY CZ DE DK EE ES FI FR GB GR HU IE IT LI LU MC NL PL PT RO SE SI SK TR

(43) Date of publication of application:
14.03.2007 Bulletin 2007/11

(73) Proprietor: **ECOLAB INC.**
St. Paul MN 55102-2233 (US)

(72) Inventor: **UHL, Stefan**
40789 Monheim (DE)

(74) Representative: **Gesthuysen, von Rohr & Eggert**
Patentanwälte
Huyssenallee 100
45128 Essen (DE)

(56) References cited:
US-A- 5 864 914 US-A- 5 920 944
US-A1- 2003 200 631

EP 1 761 155 B1

Note: Within nine months of the publication of the mention of the grant of the European patent in the European Patent Bulletin, any person may give notice to the European Patent Office of opposition to that patent, in accordance with the Implementing Regulations. Notice of opposition shall not be deemed to have been filed until the opposition fee has been paid. (Art. 99(1) European Patent Convention).

Description

[0001] The invention relates to a mop handle for a mopping device for mopping surfaces to be cleaned as well as to a mopping device comprising such a mop handle and a mop holder attached to this mop handle, and in particular a mop handle according to the generic part of claim 1 and a mopping device according to the generic part of claim 9.

[0002] Mopping devices for mopping surfaces to be cleaned are widely used in the professional and private field. However, in the professional field, the design of mopping devices needs special attention, because professional surface cleaning with high speed and efficiency needs perfect working tools. Strenuous working positions reduce working ability and increase sickness absence. The construction and handling features of mopping devices are important for increasing working efficiency of professional personnel.

[0003] Mopping devices for mopping surfaces to be cleaned with mop handle and mop holder and a mop cover attached to the mop holder are widely known from prior art and for generations (US 3,711,886 A, US 4,114,223 A, US 4,840,800 A, US 5,864,914 A). To increase working efficiency, three-dimensional mop holders with two essentially opposite, alternately useable flat sides have been provided using a removable mop cover covering both sides of the mop holder and being alternately useable either on one side or on the other side (see above-mentioned references). The preamble of claim 1 is based on the disclosure of US 2003/200631 A1.

[0004] Whereas the mop holder of mopping devices has been subject to many modifications over the years, the mop handle has remained more or less unchanged. Even so-called ergonomic handles are nothing other than traditional straight mop handles with some additional hand support, a ball-shaped upper end of the mop handle and a thermoplastic covering of the mop handle, at least in the upper end section.

[0005] There has been an attempt to improve a mop handle for increased working efficiency (US 5,920,944 A). This mop handle comprises first and second elongated cylindrical members with first and second ends, first and second angular bends intermediate the two ends in such a manner that the two long parts of the mop handle are parallel, but in different, offset planes. A swivel grip is provided on the first end of the upper part, so that the handle-holding formation provided by the swivel grip may be turned about the longitudinal axis of the upper part of the mop handle. Moreover, the lower part of the mop handle is designed as a telescopic system to adapt the length of the mop handle to the body height of the person using the mopping device.

[0006] In view of the above, the object of the present invention is to further improve working efficiency for a mopping device for mopping surfaces to be cleaned, concentrating on the mop handle.

[0007] Above-mentioned object is solved with a mop

handle according to the generic part of claim 1 by realizing the features of the characterizing part of claim 1.

[0008] The new mop handle has an articulated connection between the upper part of the mop handle and the lower part thereof. However, this articulated connection has an angle limitation so that the angle between both parts of the mop handle does not exceed a maximum value. This means that it is possible to find the most convenient working position and, in particular in connection with three-dimensional mop holder with two opposite flat sides, this position varies when the operating personnel turns the mop holder. This variation can be taken care of by the articulated connection so that the mop handle follows the needs of the person using the mopping device.

[0009] Further, for handling of the mopping device, it has been revealed as necessary that the articulated connection has a pivot axis or other pivot formation, which extends essentially along the lengthwise extension of a mop holder, in the intended attachment position of the mop holder on the mop handle.

[0010] The maximum angle for the angle limitation has been revealed to be preferably about 140°, further preferably of about 145°, most preferably of about 155°. These values are given based on the fact that the straight position is defined as 180°.

[0011] The articulated connection is particularly convenient for a person using a mopping device with such mop handle if the articulated connection is provided with a spring return means keeping both parts in their straight relative position if no external force is applied. Such spring return means may be provided by an elastomeric spring member, a conventional metallic coil spring or a pneumatic (gas) pressure element. If the spring force of the spring return means is properly adapted to the working circumstances, the mop handle may be used conventionally as a straight mop handle that, as well, has an angled mop handle according to the invention, always following the specific needs of the person using the mopping device.

[0012] A pivot axis is the most conventional articulated connection, however, some kind of other formation originating a pivot-like movement of both parts of the mop handle may be used, as well. The orientation of the specific pivot axis especially corresponds to the needs of a three-dimensional mop holder.

[0013] The articulated connection may be provided as a kind of ball and socket joint.

[0014] It is helpful if the articulated connection is provided approximately in the middle of the complete mop handle.

[0015] An additional, sometimes helpful modification of the mop handle according to the invention is provided in that the handle holding formation is provided as a part of the mop handle separate from the upper part of the mop handle and connected to the upper part of the mop handle by means of a swivel joint. This means that the hand holding the handle-holding formation needs no turn-

ing while the mopping device is moved from left to right in the usual swinging, mopping motion of a cleaning person. This reduces hand and wrist strains for the person using this kind of mopping device.

[0016] It is well known in the prior art to provide mop handles with a telescopic function so that the mop handle may be adapted to the body height of the person using this mopping device. In the specific circumstances of the invention, however, if a telescopic system is used, it should be assigned to the lower part of the mop handle.

[0017] Of course, not only the mop handle as such is covered by this invention, but also a mopping device including such mop handle together with a mop holder, in particular a three-dimensional mop holder with two essentially opposite, alternately useable flat side. Here, reference is made to a co-pending PCT application of the applicant filed the same day (PCT/EP 2004/007008, now WO-A-2006/002652).

[0018] Now, other aims, features, advantages and applications of the invention may be obtained from the following descriptions of preferred embodiments of the invention with reference to the drawings. In the drawings

Fig. 1 shows a complete mopping device with mop handle and mop holder according to the invention,

Fig. 2 shows an enlarged view of the upper part of the mop handle in operation,

Fig. 3 again shows an enlarged view of the articulated connection of the mop handle.

[0019] The mopping device shown in Fig. 1 consists of a mop handle 1 and a mop holder 2. The mop handle 1 is attached to the mop holder 2 in an articulated way, here as usual by means of a universal or cardan joint 3 as part of a handle holder. With this articulated connection, the mop holder 2 with a mop cover (not shown) attached to the mop holder 2 may be moved in a swinging movement from left to right and right to left over the surface to be cleaned either forwards or, in professional cleaning methods, mostly backwards (figure eight movement).

[0020] The mop handle 1 has a lower end section 4. This lower end section 4 is non-rotatably attached to the mop holder 2 by means of the universal joint 3. Fig. 1 indicates an attachment formation 5, which is just a spring pin fixing the lower end section 4 of the mop handle 1 in the universal joint 3.

[0021] Further, the mop handle 1 comprises an upper end section 6 for handling of the mop handle 1. In the present embodiment, the upper end section 6 is provided with a handle-holding formation 7 of, here, thermoplastic material with a form that allows easy gripping of this handle-holding formation 7.

[0022] The mop holder 2, here, is a specific mop holder with two essentially opposite, alternately useable flat

sides 8. However, whereas the inventive mop handle 1 is particularly advantageous with such a three-dimensional mop holder 2, the mop handle 1 in general is applicable with all kinds of traditional mop holders, as well.

[0023] Now, the mop handle 1 shows an articulated connection 9 provided between an upper part 10 of the mop handle 1 and a lower part 11 of the mop handle 1. The articulated connection 9 allows for a limited angle between both parts 10, 11. Figs. 2 and 3 show enlarged views of this part of the mop handle 1.

[0024] The embodiment of Figs. 1 to 3 further shows a preferred construction in that the articulated connection 9 has a pivot axis 13, which extends essentially along the lengthwise extension of the mop holder 2 when it is attached to the mop handle 1. So, together with the non-rotatable attachment of the mop handle 1 to the mop holder 2 at the handle holder, the specific mop handle 1, although provided with the articulated connection 9, allows for a directed back and forth movement of the mop holder 2 across the surface to be cleaned.

[0025] A pivot axis 13 of the articulated connection 9 of Figs. 1 to 3 is provided by a pivot pin. However, another formation that achieves essentially the same result of only one specific direction of movement of the parts 10, 11 relative to one another can be used as articulated connection 9, as well, e.g. a ball and socket joint with a guided movement to achieve the direction of the angle.

[0026] In the present embodiment, the articulated connection 9 is provided with a spring return means 12 that keeps both parts 10, 11 in their straight relative position if no external force is applied. This is helpful in practice, because the mop handle 1 may be used in a traditional way as a straight pole and, applying sufficient external force to the mop handle 1, in the inventive, angled form.

[0027] Fig. 3 shows the spring return means 12 as an intermediate phase of elastomeric compressible material between both parts 10, 11 of the mop handle 1. However, other forms of spring return means 12 can be used, e.g. an elastomeric spring member, a conventional metallic coil spring or even a pneumatic spring means like a gas pressure cartridge or the like.

[0028] In the embodiment of Figs. 1 to 3, the articulated connection 9 is provided approximately in the middle of the complete mop handle 1. So, the upper part 10 of the mop handle 1 indeed serves for handling of the mop handle 1 as indicated in Fig. 2, whereas the lower part 11 just follows the movement of the upper part 10.

[0029] The preferred embodiment of Figs. 1 to 3 shows an angle limitation of the articulated connection 9 that limits the angle between both parts 10, 11, the straight position being 180°, to a maximum of about 140°, preferably of about 145°, most preferably of about 155°. The embodiment of Fig. 2 shows an angle of about 165°.

[0030] An articulated connection 9 may, as well, be provided by an elastomeric, flexible tubing or joint that connects both parts 10, 11 of the mop handle 1 or by a corresponding elastomeric, deformable member incorporating the spring return means 12, as well.

[0031] The embodiment of Figs. 1 to 3 further has a design with a handle-holding formation 7, which is separate from the upper part 10 of the mop handle 1 and connected to this upper part 10 by means of a further swivel joint 14. So, this part of the handle is a straight extension of the upper part 10 of the mop handle 1, but, as such, may be rotated about the longitudinal axis of the upper part 10 of the mop handle 1. This is helpful for the person using such mop handle 1, in particular together with a three-dimensional mop holder 2 with two alternately useable flat sides 8.

[0032] Finally, as already disclosed by US 5,920,940 A, the lower part 11 of the mop handle 1 may be designed as a telescopic system.

Claims

1. Mop handle (1) for a mopping device for mopping surfaces to be cleaned, comprising

a lower end section (4) for non-rotatable attachment to a mop holder (2), an upper end section (6) for handling of the mop handle (1),

characterized in that

an articulated connection (9) with an angle limitation is provided between an upper part (10) of the mop handle (1) and a lower part (11) of the mop handle (1), allowing for a limited angle between both parts (10, 11), and

the articulated connection (9) has a formation originating a pivot-like movement of both parts (10, 11) of the mop handle, preferably a pivot axis (13), which extends essentially along the lengthwise extension of a mop holder (2), in its intended attachment position to the mop handle (1).

2. Mop handle according to claim 1, **characterized in that**

the articulated connection (9) is provided with a spring return means (12) keeping both parts (10, 11) in their straight relative position if no external force is applied.

3. Mop handle according to any one of the preceding claims, **characterized in that**

the articulated connection (9) is provided as a kind of ball and socket joint, or as an elastomeric, flexible tubing or joints, with a guiding means to achieve the effect of a pivot formation.

4. Mop handle according to any one of the preceding claims, **characterized in that**

the articulated connection (9) is provided approximately in the middle of the complete mop handle (1).

5. Mop handle according to any one of the preceding

claims, **characterized in that**

the angle limitation of the articulated connection (9) limits the angle between both parts (10, 11), the straight position being 180°, to a maximum of about 140°, preferably of about 145°, most preferably of about 155°.

6. Mop handle according to any one of the preceding claims, **characterized in that**

the upper end section (6) is provided with a handle-holding formation (7).

7. Mop handle according to any one of the preceding claims, **characterized in that**

the handle-holding formation (7) is provided as a part of the mop handle (1) separate from the upper part (10) of the mop handle (1) and connected to the upper part (10) of the mop handle (1) by means of a swivel joint (14).

8. Mop handle according to any one of the preceding claims, **characterized in that**

the lower part (11) of the mop handle (1) is designed as a telescopic system.

9. Mopping device for mopping surfaces to be cleaned, comprising

a mop holder (2) and a mop handle (1) attached to the mop holder (2) in an articulated way, wherein

the mop handle (1) comprises the features of one or more of claims 1 to 7.

10. Mopping device according to claim 9, **characterized in that**

the mop holder (2) is a three-dimensional mop holder (2) with two essentially opposite, alternately usable flat sides.

Patentansprüche

1. Moppgriff (1) für eine Mopporrichtung zum Moppen von zu säubernden Flächen, mit einem unteren Endabschnitt (4) für das nicht drehbare Anbringen an einen Mopphalter (2), und einem oberen Endabschnitt (6) zur Handhabung des Moppgriffs (1),

dadurch gekennzeichnet, dass

zwischen einem oberen Teil (10) des Moppgriffs (1) und einem unteren Teil (11) des Moppgriffs (1) eine gelenkige Verbindung (9) mit einer Winkelbegrenzung vorgesehen ist, wodurch ein begrenzter Winkel zwischen beiden Teilen (10, 11) gestattet ist, und die gelenkige Verbindung (9) ein Gebilde hat, von dem eine schwenkartige Bewegung beider Teile (10, 11) des Moppgriffs ausgeht und bei dem es sich vorzugsweise um eine Drehachse (13) handelt, die

sich im Wesentlichen entlang der Längserstreckung eines Mopphalters (2) in seiner beabsichtigten Anbringposition an den Moppgriff (1) erstreckt.

2. Moppgriff nach Anspruch 1, **dadurch gekennzeichnet, dass** die gelenkige Verbindung (9) mit einem Federrückholmittel (12) versehen ist, das beide Teile (10, 11) in ihrer geraden Relativposition hält, wenn keine externe Kraft ausgeübt wird.
3. Moppgriff nach einem der vorhergehenden Ansprüche, **dadurch gekennzeichnet, dass** die gelenkige Verbindung (9) als eine Art Kugelgelenk oder als ein elastomeres, flexibles Rohr oder als Gelenke mit einem Führungsmittel, so dass eine Schwenkung erzielt wird, vorgesehen ist.
4. Moppgriff nach einem der vorhergehenden Ansprüche, **dadurch gekennzeichnet, dass** die gelenkige Verbindung (9) ungefähr in der Mitte des kompletten Moppgriffs (1) vorgesehen ist.
5. Moppgriff nach einem der vorhergehenden Ansprüche, **dadurch gekennzeichnet, dass** die Winkelbegrenzung der gelenkigen Verbindung (9) den Winkel zwischen beiden Teilen (10, 11) auf maximal etwa 140°, vorzugsweise etwa 145° und besonders bevorzugt etwa 155° begrenzt, wobei die gerade Position 180° beträgt.
6. Moppgriff nach einem der vorhergehenden Ansprüche, **dadurch gekennzeichnet, dass** der obere Endabschnitt (6) mit einem Handhaltegebilde (7) versehen ist.
7. Moppgriff nach einem der vorhergehenden Ansprüche, **dadurch gekennzeichnet, dass** das Handhaltegebilde (7) als Teil des Moppgriffs (1) vorgesehen ist, und zwar getrennt vom oberen Teil (10) des Moppgriffs (1) und mittels eines Drehgelenks (14) mit dem oberen Teil (10) des Moppgriffs (1) verbunden.
8. Moppgriff nach einem der vorhergehenden Ansprüche, **dadurch gekennzeichnet, dass** der untere Teil (11) des Moppgriffs (1) als ein teleskopisches System ausgelegt ist.
9. Moppvorrichtung zum Moppen von zu säubernden Flächen, mit einem Mopphalter (2) und einem gelenkig am Mopphalter (2) angebrachten Moppgriff (1), wobei der Moppgriff (1) die Merkmale eines oder mehrerer der Ansprüche 1 bis 7 aufweist.
10. Moppvorrichtung nach Anspruch 9, **dadurch gekennzeichnet, dass** der Mopphalter (2) ein dreidimensionaler Mopphalter (2) mit zwei sich im We-

sentlichen gegenüberliegenden, abwechselnd verwendbaren flachen Seiten ist.

5 Revendications

1. Manche de balai (1) pour un dispositif de lavage pour laver des surfaces à nettoyer, comprenant une section terminale inférieure (4) constituant une fixation non rotative à un porte-balai-éponge (2), une section terminale supérieure (6) permettant le maniement du manche de balai (1), **caractérisé en ce que** une liaison articulée (9) avec une limitation angulaire est montée entre la partie supérieure (10) du manche de balai (1) et la partie inférieure (11) du manche de balai (1), et autorise un angle limité entre les deux parties (10, 11), et la liaison articulée (9) présente une disposition qui donne naissance à un mouvement du genre pivotement entre les deux parties (10, 11) du manche de balai, de préférence un axe de pivot (13) qui s'étend pour l'essentiel parallèlement à l'extension en longueur du porte-balai-éponge (2), quand celui-ci est dans la position prévue de fixation sur le manche de balai (1).
2. Manche de balai selon la revendication 1, **caractérisé en ce que** la liaison articulée (9) est dotée d'un moyen de ressort de rappel (12) qui maintient les deux parties (10, 11) alignées l'une par rapport à l'autre si aucune force extérieure n'est appliquée.
3. Manche de balai selon l'une quelconque des revendications précédentes, **caractérisé en ce que** la liaison articulée (9) se présente comme une sorte d'articulation à rotule, ou bien une gaine ou un joint souple en élastomère, avec un moyen de guidage pour obtenir l'effet d'une disposition de pivotement.
4. Manche de balai selon l'une quelconque des revendications précédentes, **caractérisé en ce que** la liaison articulée (9) se trouve à peu près au milieu du manche de balai (1) complet.
5. Manche de balai selon l'une quelconque des revendications précédentes, **caractérisé en ce que** la limitation angulaire de la liaison articulée (9) limite l'angle entre les deux parties (10, 11), cet angle étant de 180° pour la position droite, à un minimum d'environ 140°, de préférence d'environ 145°, idéalement d'environ 155°.
6. Manche de balai selon l'une quelconque des revendications précédentes, **caractérisé en ce que** la section terminale supérieure (6) est équipée d'une disposition de poignée (7).

7. Manche de balai selon l'une quelconque des revendications précédentes, **caractérisé en ce que** la disposition de poignée (7) se présente comme une partie du manche de balai (1) séparée de la partie supérieure (10) du manche de balai (1) et reliée à la partie supérieure (10) du manche de balai (1) au moyen d'un joint à rotule (14). 5
8. Manche de balai selon l'une quelconque des revendications précédentes, **caractérisé en ce que** la partie inférieure (11) du manche de balai (1) est conçue comme un système télescopique. 10
9. Dispositif de lavage pour laver des surfaces à nettoyer, comprenant un porte-balai-éponge (2) et un manche de balai (1) fixé au porte-balai-éponge (2) de façon articulée, dans lequel le manche de balai (1) présente les caractéristiques d'une ou plusieurs des revendications 1 à 7. 15 20
10. Dispositif de lavage selon la revendication 9, **caractérisé en ce que** le porte-balai-éponge (2) est un porte-balai-éponge (2) tridimensionnel avec deux côtés plats essentiellement opposés et utilisables en alternance. 25

30

35

40

45

50

55

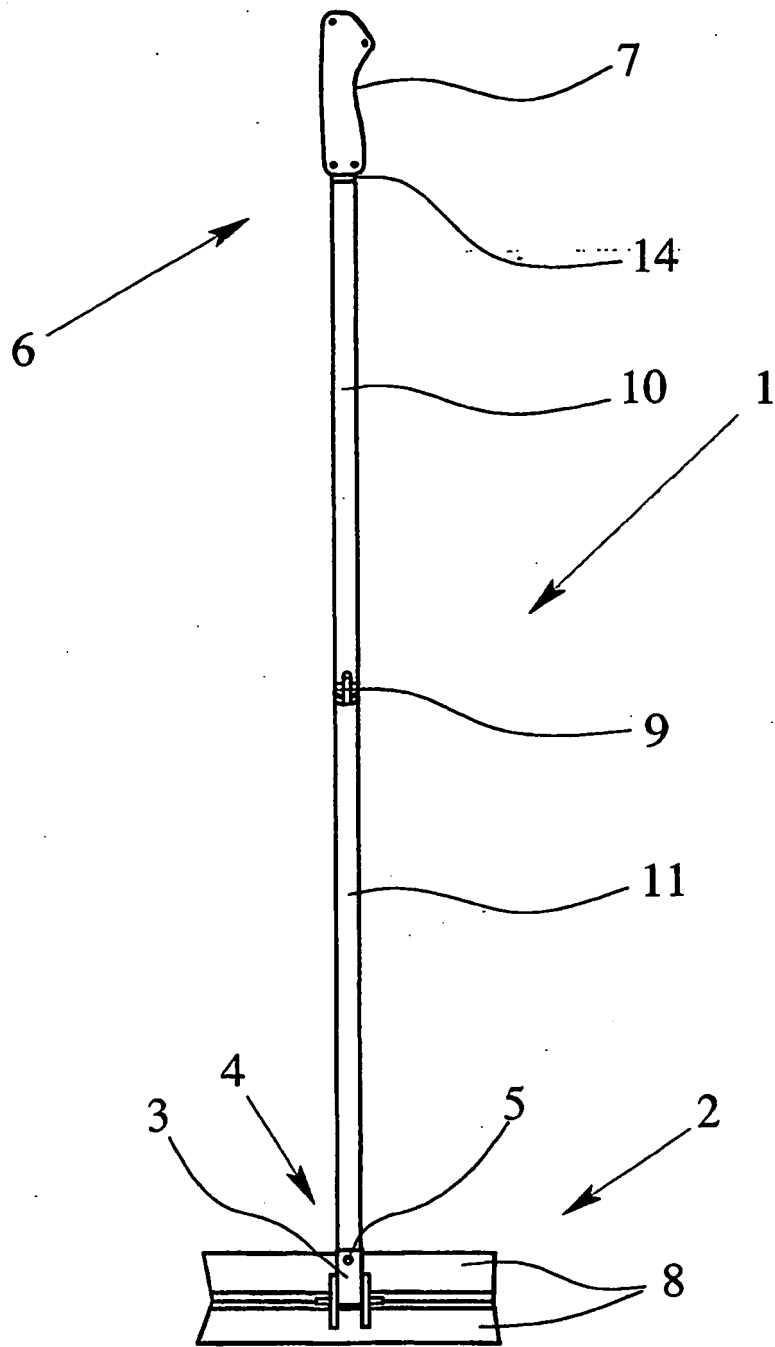

Fig. 1

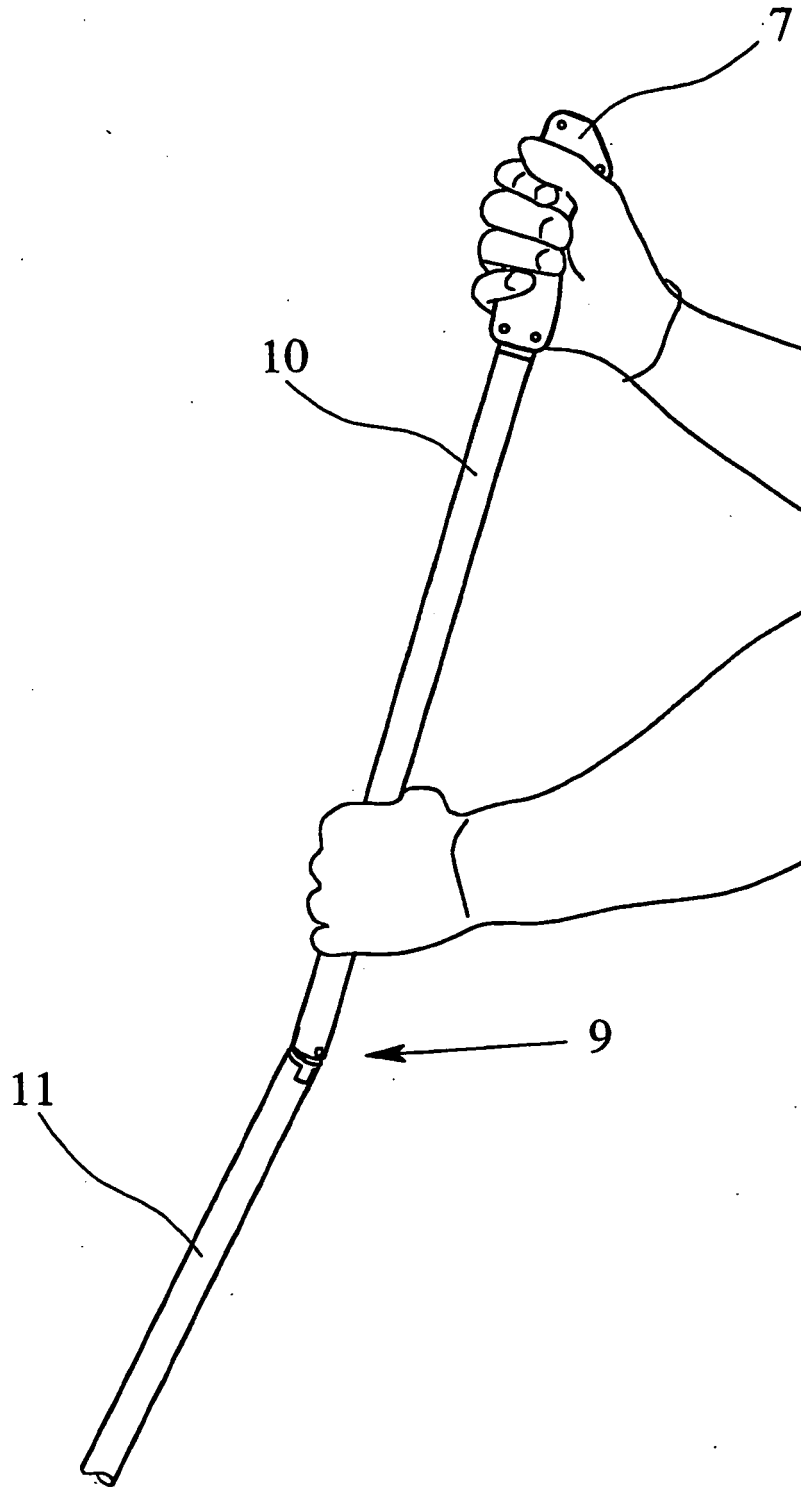

Fig. 2

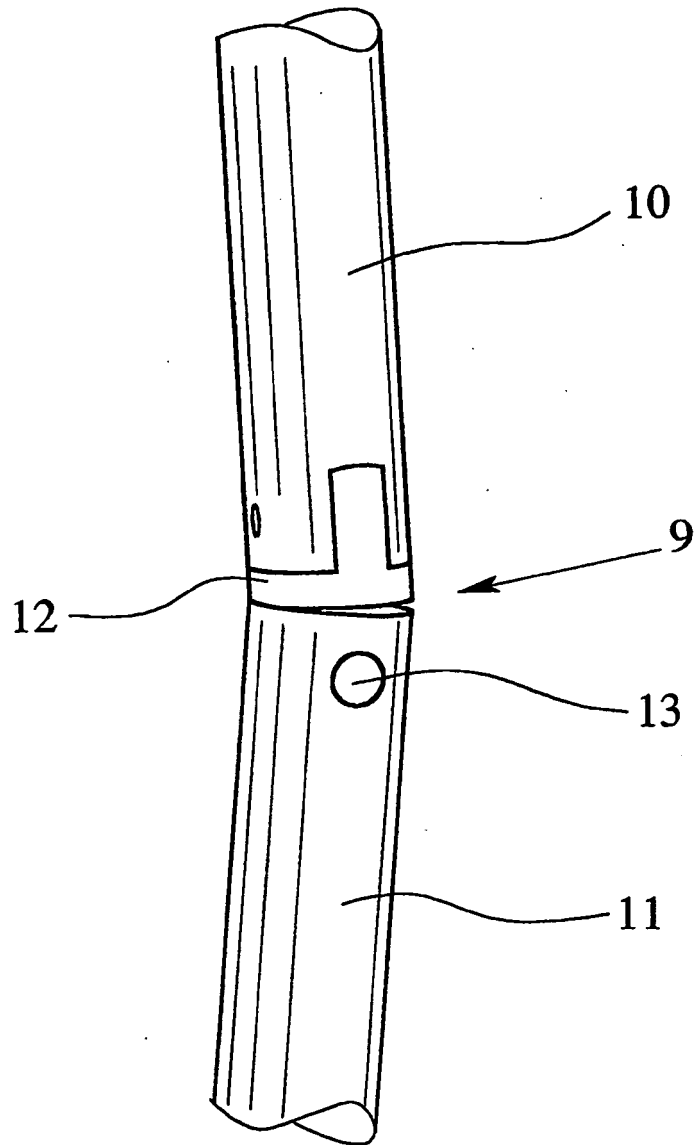

Fig. 3

REFERENCES CITED IN THE DESCRIPTION

This list of references cited by the applicant is for the reader's convenience only. It does not form part of the European patent document. Even though great care has been taken in compiling the references, errors or omissions cannot be excluded and the EPO disclaims all liability in this regard.

Patent documents cited in the description

- US 3711886 A [0003]
- US 4114223 A [0003]
- US 4840800 A [0003]
- US 5864914 A [0003]
- US 2003200631 A1 [0003]
- US 5920944 A [0005]
- EP 2004007008 W [0017]
- WO 2006002652 A [0017]
- US 5920940 A [0032]