

(No Model.)

3 Sheets—Sheet 1.

A. W. ELDREDGE.  
COMPOUND STEAM ENGINE.

No. 539,728.

Patented May 21, 1895.

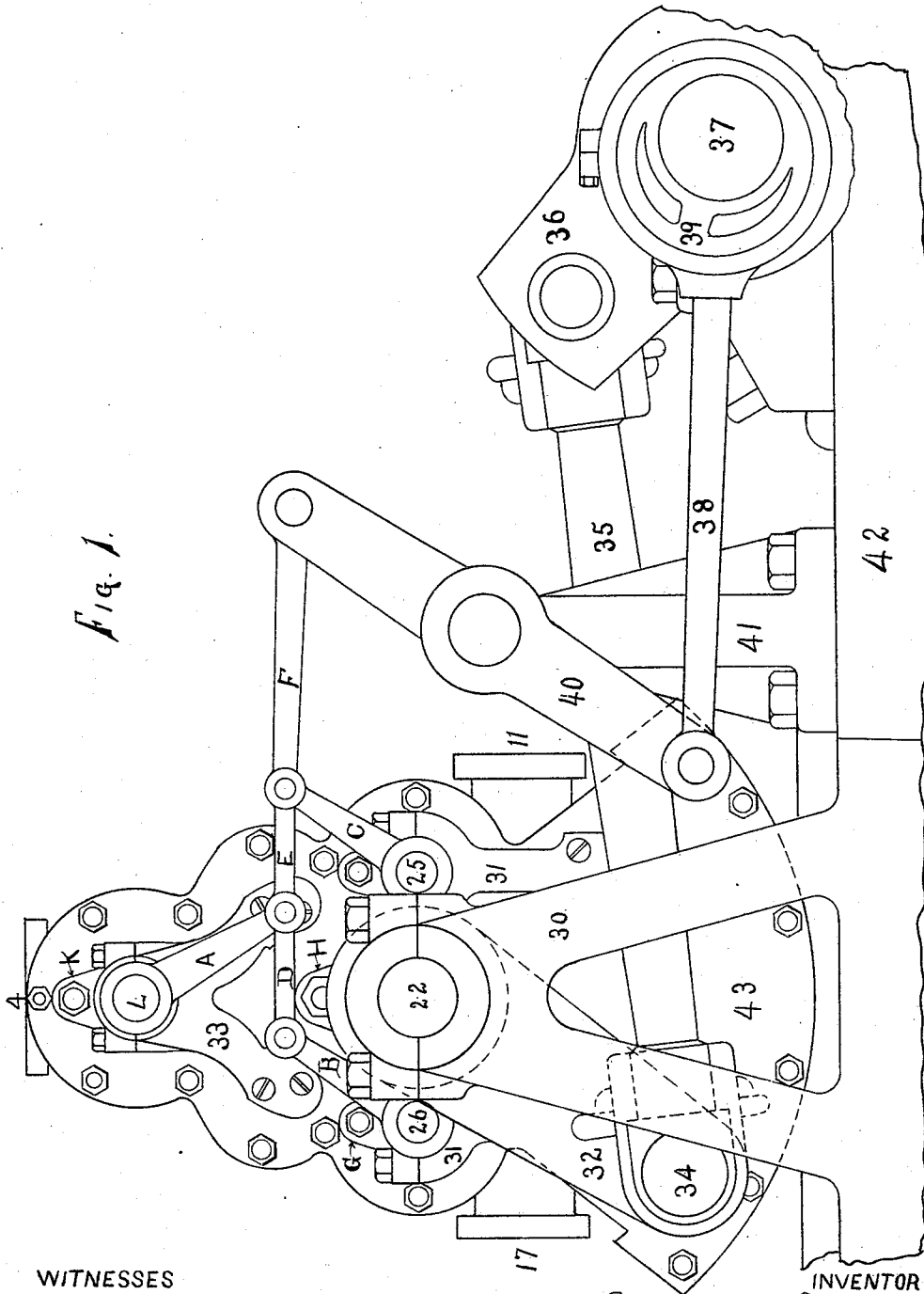

WITNESSES

*Christopher Nondelink*  
*Ambrose C. Hindman*

INVENTOR

*Alonso W. Eldredge*  
*By Edward Taggart*  
His — ATTORNEY

A. W. ELDREDGE.  
COMPOUND STEAM ENGINE.

No. 539,728.

Patented May 21, 1895.

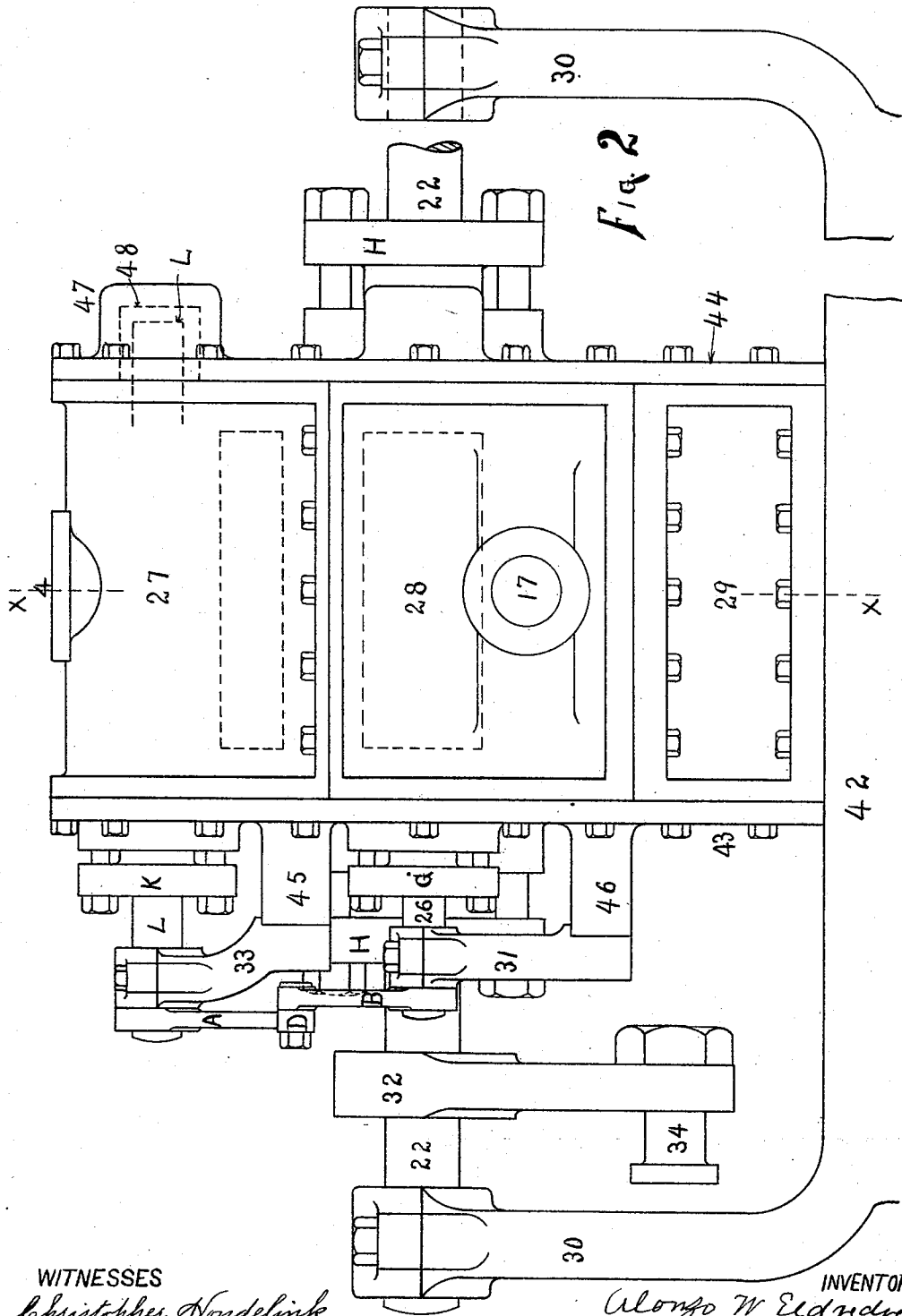

WITNESSES  
*Christopher Hondelink*  
*Ambrose C. Hindman*

INVENTOR  
*Alonzo W Eldredge*  
 By *Edward Taggart*  
 His — ATTORNEY

A. W. ELDREDGE.  
COMPOUND STEAM ENGINE.

No. 539,728.

Patented May 21, 1895.

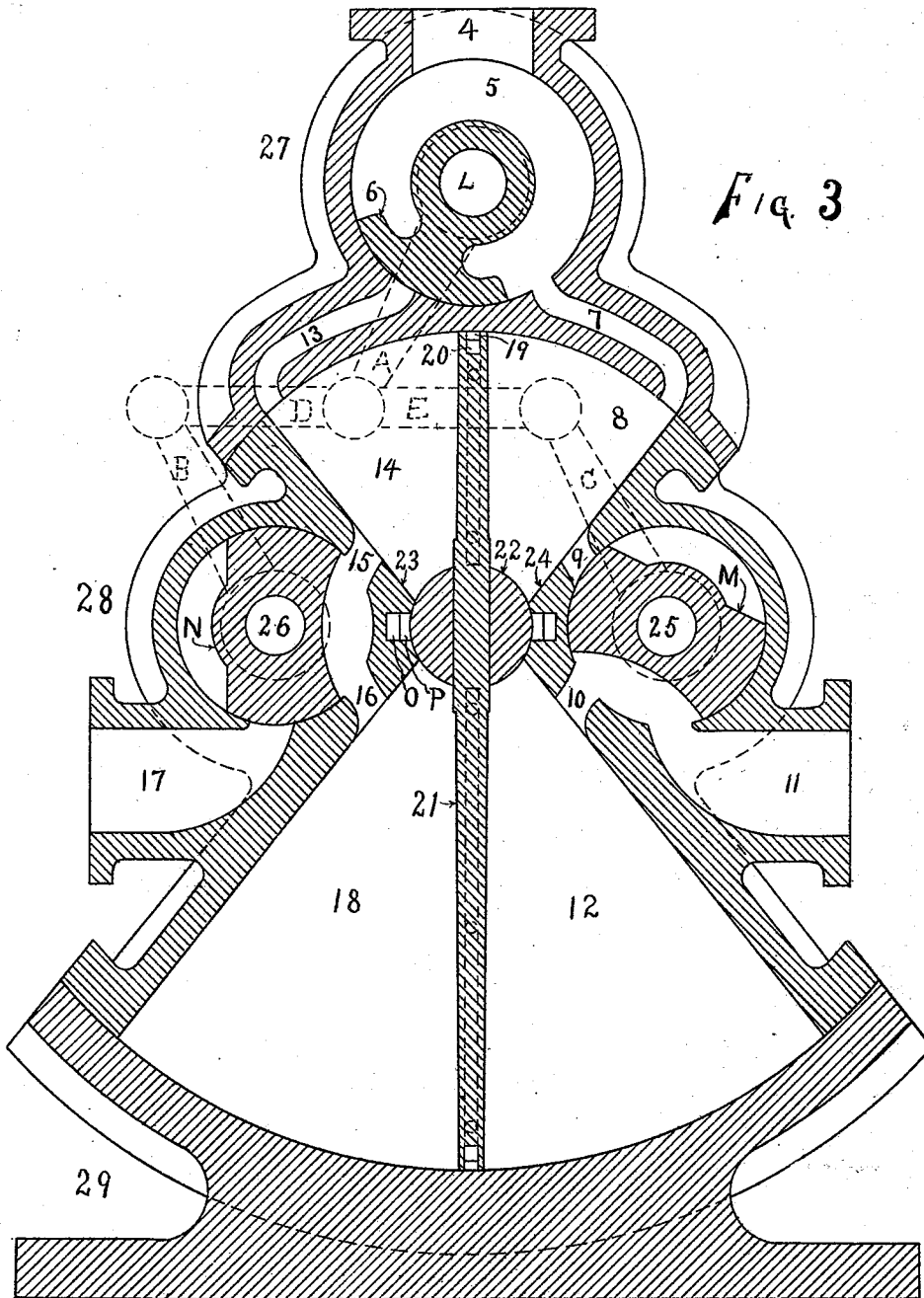

WITNESSES

*Christopher Nondelink*  
*Ambrose S. Henderson*

INVENTOR

*Alonzo W. Eldredge*  
*By Edward Baggart*  
His — ATTORNEY

# UNITED STATES PATENT OFFICE.

ALONZO W. ELDRIDGE, OF BIG RAPIDS, MICHIGAN.

## COMPOUND STEAM-ENGINE.

SPECIFICATION forming part of Letters Patent No. 539,728, dated May 21, 1895.

Application filed August 9, 1894. Serial No. 519,832. (No model.)

*To all whom it may concern:*

Be it known that I, ALONZO W. ELDRIDGE, a citizen of the United States, residing at the city of Big Rapids, in the county of Mecosta and State of Michigan, have invented certain new and useful Improvements in Compound Steam-Engines, of which the following is a specification.

This invention relates to certain new and useful improvements in compound steam engines, and the invention consists in the construction of a compound engine in which the piston oscillates on a rock-shaft, the portion of the piston at one side of the rock-shaft being considerably larger than the portion of the piston on the other side of the rock-shaft, and the same is arranged so that the shorter end of the piston is operated upon by the direct pressure of the steam, while the longer end of the piston is operated upon by the steam expansion.

It also consists in the peculiar construction and arrangement of valves, valve stems and connecting mechanism, hereinafter more fully described; and the objects of the invention are, first, to utilize the expansion of the steam upon the same piston that receives the direct pressure of the steam; second, to operate the steam valves by means of a certain new and useful arrangement of parts, hereinafter more fully described, and, third, in the construction and arrangement of the various parts which operate the engine. These objects I accomplish by means of the mechanism illustrated in the accompanying drawings, in which—

Figure 1 shows a side elevation of my improved steam-engine designed to illustrate the valve connections and their operating parts, and also the pitman and connections conveying the power from the oscillating crank-arm to the rotary crank-shaft, substantially as described. Fig. 2 shows an end elevation of the engine, in which view the piston-shaft is supported at each end; which form is considered preferable; but in small engines the support at one end may be dispensed with. Fig. 3 shows a sectional view on line *xx* of Fig. 2, illustrating the inside of the cylinder and steam-chest, together with the valves and various ports and steam, inlets and outlets.

Similar letters and figures refer to similar parts throughout the several views.

L is the valve stem. 55

A represents the valve arm which is connected to the valve stem which controls the steam ports from the steam chest into the smaller chamber of the cylinder.

25 and 26 are valve stems, and B and C are rocker arms operating the intermediate valves M and N, hereinafter described. 60

D, E and F are connecting valve arms connecting the valve arms A, B and C, and are attached to the eccentric rocker arm 40. 65

G is a stuffing box for shaft 26.

H is a stuffing box for shaft 29, and K is a stuffing box for the valve stem L, L being a valve stem supporting the valve 6 which opens and closes the ports leading from the steam chest into the cylinder. 70

M and N are intermediate valves adapted alternately to open and close the port leading from the smaller chamber of the cylinder to the larger chamber of the cylinder, as hereinafter described. 75

P is a packing strip, and O an elastic backing for the packing strip P.

4 represents the steam inlet receiving the steam from the boiler, conveying the same into the steam chest 5. 80

6 is an admission valve oscillating with valve stem L, and adapted to alternately open and close the steam ports 7 and 13, 7 being the port which conveys the steam from the steam chest to what I will term the right-hand chamber of the smaller cylinder, and 13 being the steam port which conveys the steam from the steam chest to what may be termed the left-hand chamber of the smaller cylinder, as the same appear in Fig. 3. The smaller chamber, or that part of the cylinder in which the shorter end of the piston moves is shown by 8 at the right of the piston in Fig. 3, and by 14 at the left of the piston in Fig. 3. It will be understood, however, that this is but one chamber, the piston oscillating from side to side thereof as it is turned upon the rock-shaft 22. 85

9 represents the opening from the right-hand chamber 8, when the valve is set in proper position, which allows the steam to pass from chamber 8 through 9 and 10 into the lower right hand chamber 12; 12 and 18 100

representing the space or portion of the cylinder in which the longer end of the piston oscillates.

15 15 represents the intermediate port which conveys the steam from the left-hand chamber 14 through the port or inlet 16, into the larger left-hand lower chamber 18.

11 is the steam exhaust for the lower right-hand chamber, and 17 is the steam exhaust for the lower left-hand chamber.

19 is a packing strip, making an air-tight joint between the piston and cylinder at its upper or shorter end and down its sides on both the short and long ends of the piston, making it steam-tight on all its sides and ends.

20 is an elastic packing, of any suitable material, for holding the packing strip in position to make a steam-tight joint. The lower or longer end of the piston is provided with a similar device.

22 is the main piston shaft, the piston 21 being attached thereto and rocking therewith, as above described.

23 and 24 are parts of the case and are cast solid from end of ports as shown in Fig. 2 at 27 and 28. This being a sectional view the solid parts on each end do not show. The opening for valves are drilled through, so it is the same as the webbing under a slide valve between the receiving and exhaust ports and forms the bearing for piston shaft 22 through the case, making a steam-tight joint between the upper and lower parts of the cylinder.

25 is a shaft with which the valve M oscillates, and 26 is a shaft with which the valve N oscillates.

27 represents the upper section or shell, as I prefer to construct the engine.

28 is the middle section of the shell and 29 is the lower section and base.

30 is a support for the main shaft 22, on both sides of the cylinder as shown in Fig. 2, and 31 serves as a support for the shafts 26 and 25.

32 In Fig. 2 one of the side supports 30 is shown detached in order that the figure might contain the entire view of the engine, but it will be understood that the supports 30 and 30 are alike at both sides of the engine.

32 is an oscillating arm conveying the oscillating motion from the shaft 22 to the wrist-pin 34 on the pitman 35.

33 is the support for the valve stem L.

35 is a pitman, connected by a suitable crank 36 and the ordinary wrist-pin. The crank 36 is connected to and conveys the rotary motion to the crank shaft 37.

38 is an eccentric rod operated by the eccentric 39, and connecting the eccentric 39 with the eccentric rocker arm 40.

41 is a support for the rocker arm.

42 is the engine bed.

43 and 44 are cylinder heads or caps.

45 is a lug on the cylinder head 43 to support the bracket support 33, and 46 is a lug on said cylinder head which supports the bracket support 31.

47 is a lug on the cylinder head 44 designed to support the babbitted bearing 48 which is cast around the valve stem L, and forms the support for that end of the valve stem L.

In Fig. 3 the piston 21 is shown in perpendicular position, and the chambers 8 and 14 are shown of equal size, while the longer or lower portion of the piston 21 is about twice the length of the upper portion of the piston 21. This is the proportion which I prefer, but the proportion may be varied to suit the operator or different sizes of engines.

The operation of my steam engine is as follows: If we suppose that the chamber 14 is full of live steam, and the upper end of the piston is turned so as to reach its farthest stroke to the right, while the lower end reaches the left of the lower chamber 18, and the valve 6 is then moved so as to allow the live steam to pass from the steam chest 5 through the port 7, the steam will bear with its full force directly upon the right side of the upper or shorter end of the piston, moving the same to the left, while the steam which had filled the upper chamber 14, which as above described would be practically the entire upper portion of the cylinder, passes through the intermediate ports 15 and 16, and by its expansion presses against the left-hand side of the longer portion of the piston 21, not only counterbalancing the pressure against the left-hand side of the shorter portion of the piston, but, inasmuch as the lower end of the piston is much larger the steam will assist in giving the rocking motion to the piston, and thus the live steam direct from the steam chest will have but little back pressure on the shorter end of the piston, while the steam expanding in chamber 18 will assist in giving the rocking motion to the piston and gaining the benefit of the fulcrum.

When the upper end of the piston has reached its farthest left-hand stroke, and the lower end of the piston the farthest portion of its right-hand stroke, the steam exhausts from the chamber 12 through ports 10 and 11. Then the valve 6 will be moved so as to allow the steam to pass through the port 13 for the return stroke of the piston, while the valve M will be turned so as to allow the steam to pass from chamber 8 into chamber 12, thereby operating to reverse the stroke. In this way the piston is made to oscillate backward and forward, the exhaust steam at all times assisting the direct pressure in the operation. The valves are operated through the arms D, E and F, which are pivoted together, connected to the valve stems and also connected to the rocker eccentric 40, which is operated as above described from the eccentric 39.

The advantage of this construction is its simplicity, and also in the use of a single shaft with a single piston supported on the shaft to receive the force of the direct pressure of the steam at its shorter end, and the force of the steam expansion at its longer end alternately, in the manner described.

Having thus described my invention, what

I claim to have invented, and desire to secure by Letters Patent, is—

1. In a compound steam engine, the combination of a steam chest, a cylinder composed of two chambers of unequal size, an oscillating piston supported on a shaft journaled intermediate said chambers, and having its shorter end fitted in the smaller chamber and its longer end in the larger chamber, ports connecting the steam chest with the smaller chamber upon opposite sides of the piston, an oscillating valve arranged in said steam chest for alternately admitting steam to said ports, ports arranged intermediate the two chambers of the cylinder upon opposite sides of the piston, oscillating valves controlling said ports for alternately conveying steam from the smaller chamber to the larger, and means for simultaneously operating the valves in the steam chest and intermediate ports, substantially as described.

2. In a compound steam engine, the combination with a cylinder composed of two

chambers of unequal size, a piston oscillating in said chambers, a steam chest connected with the smaller chamber on opposite sides of the piston by ports, an oscillating valve 6 journaled on a valve stem L in said chest, valves M and N controlling passages connecting said chambers on opposite sides and provided with valve stems 25 and 26, connecting arms D, E, connecting said valves and the valve in the steam chest, an arm F connected to one of said arms, a drive shaft, an eccentric 39 mounted on the drive shaft, the eccentric rod 38 actuated thereby, and a rocking arm 40 connected at one end to the eccentric rod and at its other end to the arm F, substantially as described.

In witness whereof I have hereunto set my hand and seal in the presence of two witnesses.

ALONZO W. ELDREDGE. [L. S.]

Witnesses:

GEO. BEVIER,  
FRANK E. HARDY.