

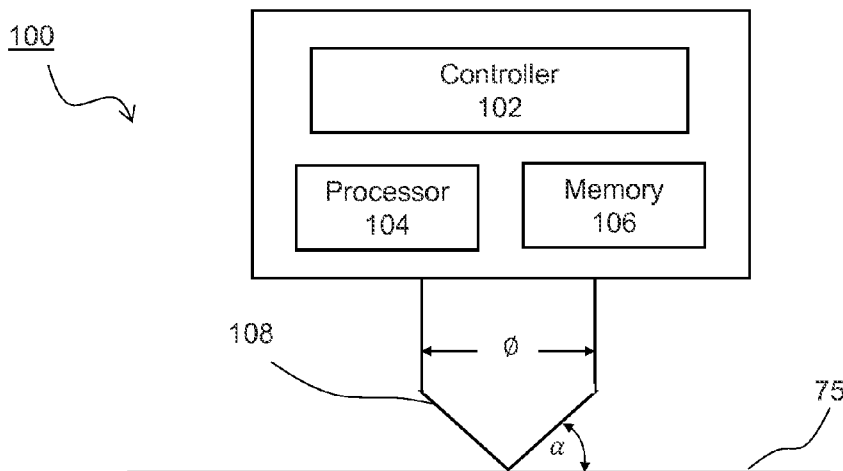

- (51) International Patent Classification: *G06F 19/00* (2011.01)
- (21) International Application Number: PCT/US2015/049224
- (22) International Filing Date: 9 September 2015 (09.09.2015)
- (25) Filing Language: English
- (26) Publication Language: English
- (30) Priority Data: 62/048,073 9 September 2014 (09.09.2014) US
- (71) Applicant: **xCORNELL UNIVERSITY** [US/US]; Center for Technology Licensing ("CTL") at Cornell University, 395 Pine Tree Road, Ithaca, New York 14850 (US).
- (72) Inventors: **GUIMBRETIERE, Francois**; 404 Winthrop Dr, Ithaca, New York 14850 (US). **IM, Sangha**; 629 Millich Dr., Campbell, CA 95008 (US). **BAUDISCH, Patrick**; Oranienburger Strasse 17, 10178 Berlin (DE). **MÜLLER, Stefanie**; Schillerstrasse 27, 10625 Berlin (DE). **GUREVICH, Serafima**; Ridbacher Str. 57 A, 12621 Berlin (DE). **PFISTERER, Lisa**; Lüderitzstraße 3, 13351 Berlin (DE). **TEIBRICH, Alexander**; Wattstrasse 5A, 14482 Potsdam (DE).
- (74) Agents: **CORDER, Allison M.** et al.; Valauskas Corder LLC, 150 S. Wacker Drive, Suite 620, Chicago, Illinois 60606 (US).
- (81) Designated States (*unless otherwise indicated, for every kind of national protection available*): AE, AG, AL, AM, AO, AT, AU, AZ, BA, BB, BG, BH, BN, BR, BW, BY, BZ, CA, CH, CL, CN, CO, CR, CU, CZ, DE, DK, DM, DO, DZ, EC, EE, EG, ES, FI, GB, GD, GE, GH, GM, GT, HN, HR, HU, ID, IL, IN, IR, IS, JP, KE, KG, KN, KP, KR, KZ, LA, LC, LK, LR, LS, LU, LY, MA, MD, ME, MG, MK, MN, MW, MX, MY, MZ, NA, NG, NI, NO, NZ, OM, PA, PE, PG, PH, PL, PT, QA, RO, RS, RU, RW, SA, SC, SD, SE, SG, SK, SL, SM, ST, SV, SY, TH, TJ, TM, TN, TR, TT, TZ, UA, UG, US, UZ, VC, VN, ZA, ZM, ZW.
- (84) Designated States (*unless otherwise indicated, for every kind of regional protection available*): ARIPO (BW, GH, GM, KE, LR, LS, MW, MZ, NA, RW, SD, SL, ST, SZ, TZ, UG, ZM, ZW), Eurasian (AM, AZ, BY, KG, KZ, RU, TJ, TM), European (AL, AT, BE, BG, CH, CY, CZ, DE, DK, EE, ES, FI, FR, GB, GR, HR, HU, IE, IS, IT, LT, LU, LV, MC, MK, MT, NL, NO, PL, PT, RO, RS, SE, SI, SK, SM, TR), OAPI (BF, BJ, CF, CG, CI, CM, GA, GN, GQ, GW, KM, ML, MR, NE, SN, TD, TG).

[Continued on next page]

(54) Title: SYSTEM AND METHODS FOR THREE-DIMENSIONAL PRINTING



(57) Abstract: A fast and economical system and methods directed to low-fidelity fabrication of three-dimensional (3D) objects using 3D printing. The invention facilitates rapid prototyping by providing a wireframe structure in the form of the underlying design structure of a 3D model, which may be useful for a variety of reasons including to provide a prototype preview that may be used for design validation of a 3D model.

FIG. 1



Declarations under Rule 4.17:

- as to the identity of the inventor (Rule 4.17(i))
- of inventorship (Rule 4.17(iv))

- before the expiration of the time limit for amending the claims and to be republished in the event of receipt of amendments (Rule 48.2(h))

Published:

- with international search report (Art. 21(3))

SYSTEM AND METHODS FOR THREE-DIMENSIONAL PRINTING

CROSS-REFERENCE TO RELATED APPLICATIONS

This application claims the benefit of U.S. Provisional Patent Application
5 No. 62/048,073 filed September 9, 2015, incorporated by reference.

FIELD OF THE INVENTION

The invention relates generally to computer systems and methods for
fabricating three-dimensional (3D) objects using 3D printing. More specifically,
10 the invention is directed to fast fabrication (i.e., rapid prototyping) of 3D objects in
the form of wireframe structures. The wireframe structures may be useful for a
variety of reasons including to provide a prototype preview that may be used for
design validation of a 3D model.

15 BACKGROUND OF THE INVENTION

Three-dimensional (3D) printing is any process used to manufacture a 3D
object. For example, material may be deposited sequentially by a 3D printer (i.e.,
print head) to manufacture an object. 3D printers are used, for example, in
industrial, educational, and demonstrative applications and are capable of
20 manufacturing large objects as well as nanoscale-size objects. For example, 3D
printing is used as a rapid prototyping tool allowing designers to prototype "one-
off" objects and to iterate over designs.

Unfortunately, certain 3D printers are inherently slow by fabricating objects
voxel-by-voxel and layer-by-layer. Therefore, a reasonably sized object may take
25 a long time to print (i.e., overnight, days, etc.) slowing the design process – such
as producing a single iteration per day. This supports that 3D printers used for
quick design iteration is not yet entirely optimal. In other disciplines, such as in

user interface design, designers achieve a fast and efficient process by iterating from low-fidelity prototyping techniques to high-fidelity techniques.

In order to allow designers to iterate quickly, low-fidelity techniques, such as sketching and paper prototyping, give priority to speed over functionality. This trade-off pays off in the early phases of design because it encourages the quick exploration of several versions before committing further resources, eventually leading to a better design.

Certain personal fabrication methods include newly proposed interfaces for a wide variety of prototype applications, for example, *Printed Optics* for optical sensors and display elements, *Printing Teddy Bears* for fabrication of soft objects for wearable technology, manufacture of free-form audio technology, and *Sauron* for creation of interactive controllers using a single camera. With these newly proposed interfaces, the traditional workflow remains the same in that users first create a digital model in a CAD program.

In contrast, interactive fabrication systems offer an alternative between user and system control. For instance, *ModelCraft* allows users to modify physical paper models by annotating directly on the model, *CopyCAD* allows users to copy geometry from existing objects using a milling machine, and a constructable interactive fabrication system allows users to directly draw on the work-piece inside a laser cutter using a handheld laser pointer. Different approaches try to reduce 3D printing time by either massively parallelizing the printing process using multiple heads or by assembling objects layer-wise from prefabricated voxels of equal size.

According to the typical traditional workflow, a 3D model is printed using slow hi-fidelity fabrication. In contrast, low-fidelity fabrication prints all

intermediate versions using fast low-fidelity fabrication creating prototype previews. Only at the end of the design process, when the design is finished, the complete 3D model is printed using hi-fidelity fabrication.

One low-fidelity fabrication approach is known as "faBrickation". This approach limits the 3D printing process to regions where high-resolution is required and substitutes less crucial portions of a 3D model with Lego-style bricks. Unfortunately, faBrickation requires manual assembly of the bricks, effectively trading in printing time for manual effort.

Therefore, there is a need for an improved 3D printing low-fidelity approach that is fully automated for fast fabrication of 3D objects. More specifically, there is a need for 3D printing of wireframe structures, which may be useful as prototypes enabling designers to preview designs for validation of a 3D model. The invention satisfies these needs.

15 SUMMARY OF THE INVENTION

The invention relates generally to computer systems and methods for three-dimensional (3D) printing. The invention provides a low-fidelity fabrication approach that is fully automated and fast. In particular, the invention is directed to 3D printing for fast fabrication of 3D objects in the form of a wireframe structure, which may be used as a prototype preview. The term "prototype preview" refers to a visual presentation of the underlying design structure of a 3D model, which may be useful for a variety of reasons including to provide a prototype preview that may be used for design validation of a 3D model.

More specifically, a prototype preview is constructed of a wireframe structure – a 3D printed object whose surfaces have been replaced with wireframe mesh, otherwise referred to as "mesh pattern". A mesh pattern is

created by specifying each edge of the physical object where two mathematically continuous smooth surfaces meet, or by connecting an object's constituent vertices using straight lines or curves. The mesh or mesh pattern is not limited to any particular geometry or configuration.

5 3D wireframe structures created according to the invention allow designers to quickly validate the high-level design of a 3D object, such as its ergonomic fit. As an example, if a designer notices that a particular bottle design does not yet rest comfortably in the hand, the designer can change the model by adjusting the thickness of the bottle in a 3D modeling program. The 3D object is converted
10 according to the system and methods of the invention and it is reprinted. The designer may repeat the process until the bottle achieves the desired fit.

3D wireframe structures according to the invention also save on material costs in that the wireframe previews use only a fraction of material required, making it affordable to iterate designs including during the early stages. It is
15 contemplated that in addition to solely wireframe structures, hybrid structures may be fabricated that incorporate both wireframe structures and solid structures such as those fabricated using layer-wise printing. Hybrid structures allow additional detail to be printed, for example, surface features. The mix of both techniques allows for quick iteration while ensuring enough detail in those regions
20 where it is required.

Yet it is further contemplated that certain 3D models may require closed surfaces. According to one embodiment, surfaces may be closed by dipping the wireframe structure into glue, which may also realize the added advantage of strengthening the model.

The invention advantageously can be implemented in a 3D printer, as a service, on a peripheral device in communication with a 3D printer, as a stand-alone device, or as a software program either configured with existing systems before or after market. As examples, the methods according to the invention may
5 be configured as an option in a print dialog, a selectable control on the printer or peripheral device, to name a few.

Although the invention is described according to a 3D printing embodiment, it is contemplated the invention is applicable to other types of additive manufacturing embodiments such as extrusion and sintering based
10 processes. More specifically, it is contemplated the invention may be used with any type of additive manufacturing including both delta design and Cartesian-based printers, for example, stereolithography (SLA), fused deposition modeling (FDM), selective laser sintering (SLS), selective laser melting (SLM), electronic beam melting (EBM), or laminated object manufacturing (LOM). In addition, any
15 degree of freedom (DOF) is contemplated. For example, one embodiment of the invention is implemented using a 3-axis FDM printer such as those known as *PrintrBot*, *Kossel mini*, *MakerBot*); however, any number degree of freedom (DOF) printing device is contemplated.

According to one particular embodiment, the invention operates
20 particularly fast on a delta design since these printers allow the print head to move up and down quickly. However, it is also contemplated that the invention be made equally fast on Cartesian printers with the proper hardware design, i.e. by changing both the movement/turn ratio and the stepper motor speed in the z-direction since the axis speed in the z-direction is simply a design decision of the
25 manufacturers.

An advantage of the invention is that it achieves speed-ups of up to a factor of 10 compared to traditional layer-wise (i.e., layer-by-layer) printing. This is accomplished by reducing the solid model to a representation of a surface and then reducing the surface to a wireframe mesh. In particular, the volume of the object is reduced by using an efficient mesh pattern. In certain embodiments, the mesh pattern may be, for example, a "zig-zag" type pattern, but any suitable pattern is contemplated.

Although the invention may print an object layer-wise, it is a preferred embodiment of the invention that filament be directly extruded into 3D space. This creates the edges of the wireframe model directly one stroke at a time. Another advantage of the invention is that it requires less support edges than regular layer-wise 3D printing with capability of printing overhangs of up to 90°. This is accomplished by extruding material under tension.

According to the invention, objects may be constructed using any type of filament material, including for example, Acrylonitrile Butadiene Styrene (ABS), Polylactic Acid or Polylactide (PLA), high-density polyethylene (HDPE) or any suitable material that can be extruded to form the object. In particular embodiments that require frequent transitions between wireframe and solid, filament materials that have a quick transition time are preferred such as ABS that requires a smaller temperature range to change its viscosity from compliant to solid.

According to one embodiment of the invention, custom g-code is generated. G-code is the common name for the most widely used numerical control (NC) programming language. However, the invention contemplates any language in which computerized machine tools are instructed on how to make

something (i.e., where to move, how fast to move, and through what path to move). In certain embodiments, the g-code is loaded into standard 3D printing software for printing. In certain other embodiments, the g-code is integrated into the 3D printing device. Specifically, the custom g-code moves the print head
5 along the desired path and controls how much material is extruded at which points in order to fabricate a wireframe structure.

The invention and its attributes and advantages may be further understood and appreciated with reference to the detailed description below of one contemplated embodiment, taken in conjunction with the accompanying
10 drawings.

BRIEF DESCRIPTION OF THE DRAWINGS

The preferred embodiments of the invention will be described in conjunction with the appended drawings provided to illustrate and not to limit the
15 invention, where like designations denote like elements, and in which:

FIG. 1 illustrates an exemplary system that may be used to implement the invention.

FIG. 2A illustrates a block diagram of a collision constraint according to the invention.

20 FIG. 2B illustrates another block diagram of the collision constraint according to the invention.

FIG. 3A illustrates a block diagram of a deformation constraint according to the invention.

25 FIG. 3B illustrates another block diagram of the deformation constraint according to the invention.

FIG. 4A illustrates a block diagram of a material transition constraint according to the invention.

FIG. 4B illustrates another block diagram of the material transition constraint according to the invention.

5 FIG. 5 illustrates a flow chart of a method according to one embodiment of the invention.

FIG. 6 illustrates a flow chart of another method according to another embodiment of the invention.

10 FIG. 7 illustrates a block diagram of a segment according to one embodiment of the invention.

DETAILED DESCRIPTION OF EMBODIMENTS OF THE INVENTION

Unlike traditional 3D printers that stack filament material on filament material, the invention fabricates objects by alternating between (a) printing a
15 contour or layer and (b) printing a mesh pattern on top of the contour.

FIG. 1 illustrates an exemplary 3D printing device 100 according to the invention. 3D printing device 100 is capable of fabricating a 3D object and includes at least a controller 102, a processor 104, and a memory 106. The printing device 100 includes a print head 108 that extrudes filament material onto
20 a support surface 75 such as a platform or plate. The device 100 uses digital data such as a CAD model.

The invention advantageously can be implemented in a 3D printer, for example, as software stored in memory 106. The software may be in the form of a program configured with existing systems either before or after market. The
25 software is processed by the processor 104 such that the controller 102 controls the device 100, i.e., moves the print head along the desired path and controls

how much material is extruded at which points in order to fabricate a wireframe structure.

The methods according to the invention can be implemented on any printing device based on the following parameters – (1) diameter \emptyset of the print
5 head and (2) angle α of the slanted portion of the print head. These parameters are used to determine the mesh pattern of the wireframe structure such that collisions – between filament material and/or filament material and the print head – are prevented. The printer parameters may dictate the depth the print head can reach to extrude filament material without colliding with already printed
10 material and the distance the print head can travel to extrude filament with a spacing that avoids collisions with already printed material.

Specifically, the diameter \emptyset of the print head limits the spacing between two vertical or support edges. As shown in FIG. 2A, two vertical edges need to be spaced at least half the diameter of the print head apart to avoid a collision
15 between the print head and already printed material.

In certain embodiment, the angle α of the slanted portion of the print head (along with the diameter \emptyset) may be used to determine the depth or how far the print head can reach while printing a wireframe structure without the print head colliding with that already printed: $\text{max depth} = \left(\frac{\emptyset}{2}\right) \tan \alpha$. However, in certain
20 other embodiments, the depth the print head can be increased beyond the max depth by using an extender element attachable to the print head. In either contemplated embodiment material cannot be extruded at a depth steeper than the slant of angle α or the print head itself as shown in FIG. 2B, as steeper edges can cause the slanted tip of the print head to collide with either that already
25 printed or with that currently being printed.

FIG. 3A and FIG. 3B illustrate block diagrams of an edge deformation constraint according to the invention. Edge deformation must be considered resulting when filament material is not yet solidified during fabrication. In order to obtain the intended result in FIG. 3A, it can be seen that the filament material acting as a support edge must be cooled and solidified prior to fabricating any downward edges. This may be done by simply adding a temporal pause or delay at the end of each floating edge allowing filament material to cool and harden.

In addition to compensating for edge deformation, material transition time must be considered. As shown in FIG. 4A and FIG. 4B, the invention anticipates deformation by extending the vertical movement of the print head before beginning the downward stroke to fabricate the downward edge.

The quality of the system and methods of the invention is improved by not only reducing overall speed with which the print head moves, but also allowing filament material to solidify as it is being printed. In one embodiment, this may be achieved by using an air flow to cool the material. For example, one or more air jets controllable by a solenoid valve may be attached to the print head. The additional cooling causes the filament material to solidify faster after extrusion. It is also contemplated that the air flow can be reduced or turned off such as in circumstances in which filament material needs to stick to another part of the model. Alternatively, the invention may make use of a built-in fan or integrate an additional pause to wait for material to solidify before continuing on to print the next feature. It is contemplated that a more aggressive cooling process increases speed of fabrication.

FIG. 5 illustrates a flow chart of a method 200 according to one embodiment of the invention. At step 210, a 3D model is received for processing.

According to one embodiment the 3D model is in stereolithography (STL) format, but any format is contemplated such as polygon file format or a triangle format (PLY).

The 3D model is converted to a vector representation at step 230. The
5 vector representation may include one or more points, lines, curves, polygons, etc. The vector representation is used to determine the print order of the object at step 250 as more fully discussed in reference to FIG. 6. At step 270, the vector representation is translated into g-code of a 3D printer representation of the wireframe structure based on the order for printing segments of the vector
10 representation.

At step 290, the printer is instructed to execute the g-code to print the printer representation. At step 300, the wireframe structure is printed as strokes in 3D space. According to one exemplary embodiment, the invention creates segments by moving the print head up and down repeatedly. Specifically, the
15 printing device extrudes filament material from the print head based on the order for printing segments to fabricate the wireframe structure. It should be noted that a larger opening in the extrusion nozzle print head leads to thicker and thus sturdier edges and thus to sturdier objects. On the flipside, thicker edges require more time to cool down, which slows down the printing process. As an example,
20 in one embodiment a 0.7mm extrusion nozzle provides both sturdy and fast to print results.

FIG. 6 illustrates a flow chart of a method 250 for determining the print order of the object according to one embodiment of the invention. Parameters of the printing device are registered at step 251. The parameters include an angle
25 of the print head defined from a horizontal axis and a diameter of the print head.

These parameters dictate the constraints of the mesh pattern used in fabricating the wireframe structure of the 3D model in order to prevent collisions with filament material during printing. More specifically, the printer parameters α and \emptyset may dictate the depth the print head can reach to extrude filament material
5 without colliding with already printed material and the distance the print head can travel to extrude filament material with spacing to avoid collisions with already printed material.

In particular, the parameters are used to calculate a depth at step 253 defined along a vertical axis at which the print head deposits a material and at
10 step 255 to define a plane at the angle of the print head at which the print head deposits the material. The depth and the plane define a portion of space viable for printing the wireframe structure without collisions. As mentioned above, the depth may be increased through use of an extender element attachable to the print head

15 At step 257, the model is sliced into segments using the depth as the maximum thickness or height of the segment (see FIG. 7). As mentioned above, the depth cannot be steeper than the slant of angle α or the print head itself.

The locations of the segments are determined by (1) important features on the model geometry, and (2) the minimum and maximum height of the mesh
20 pattern between two subsequent segments. In one embodiment, the invention slices the 3D model into segments along a z-axis forming horizontal slices (width and length of the object's bounding box) at a specific height using a Boolean intersect operation. It is also contemplated the 3D model may be sliced into segments along an x-axis forming one or more vertical slices.

According to a particular embodiment, for each segment the invention extracts the top layer by converting it to a high-resolution bitmap and then applying an algorithm, for example, OPENCV's FINDCONTOUR. If there are multiple layers on one segment, the relationship to each other is known, i.e. whether they
5 are located next to each other or contained in each other.

At step 259, a mesh pattern is defined. Again, the mesh pattern is determined by the parameters of the print head of the printing device. For example, as described more fully in reference to FIG. 7, the vertical or support edges of an exemplary mesh pattern have a height equal to the depth the print
10 head can reach (also equal to the maximum thickness or height of the segment). The downward edges of the exemplary mesh pattern are limited by the angle or slanted edge of the print head. The mesh pattern is positioned between two consecutive contours or layers.

When generating the mesh pattern, the invention maximizes the object's
15 physical stability by aligning all vertical lines across segments. Simply using the points from the segment below does not work, because subsequent segments might: (1) have a different length, which can lead to insufficient space between two subsequent points (print head collision), and (2) segments might have different heights, which can lead to invalid printing angles. Therefore, a mixed
20 approach is used by first calculating the optimal even spacing of points for each layer and then calculating the minimum distance from a point on the bottom segment to the top segment. The average of both is used to promote good stability and a comparably homogeneous spacing. In the case where two vertical lines are still too close to each other, one is simply ignored. In addition, all
25 geometrical modifications are implemented due to the mechanical properties of

the filament material and print head such as removing the last diagonal edge of the mesh pattern from the list of edges to avoid print head collision. In other embodiments where a segment has a single contour and its subsequent segment has two contours (and vice versa), they are printed on top of each other without the intermediate mesh pattern. This particular approach may be used in instances to ensure that any mesh pattern of each new segment has filament material printed underneath it.

FIG. 7 illustrates a block diagram of a segment 300 according to one embodiment of the invention. The embodiment as shown in FIG. 7 is in the form of a "zig-zag" type pattern that is triangle based, however any suitable pattern is contemplated such as one that is not triangle-based (i.e. without a support edge, for example). As shown, each segment 300 includes a first layer or contour 310 positioned from a second layer or contour 320. The distance between the contours 310, 320 is equal to the depth $-\left(\frac{\phi}{2} \tan \alpha\right)$ or as determined by using an extender element attachable to the print head. The surface 315 between the layers 310, 320 is replaced with the mesh pattern 330. The mesh 330 joins the first layer 310 and the second layer 320 and includes a support edge 332 connected to a downward edge 334, the downward edge 334 limited by the angle of the print head from a horizontal axis shown by α .

As mentioned above, the invention translates the vector representation into a printer representation using g-code. Specifically, a list of edges including all contours and mesh patterns are exported for printing. The coordinates for the start point and end point of each edge are used to generate the movement commands for the print head and the length of the edge to determine how much

extrusion is required. Additionally, g-code is generated to command any cooling mechanism, i.e., turn the fan on/ off to properly cool the wireframe edges.

As mentioned above, the invention may be used in combination with layer-wise printing to obtain a hybrid structure. This is accomplished by generating
5 additional segments between two subsequent segments. The number of additional segments depends on the printing resolution (e.g. if two wireframe segments are 3.5mm apart and the extrusion nozzle is 0.7mm, the invention generates $3.5\text{mm}/0.7\text{mm} = 5$ additional layers). After generating the segments and extracting their contours, the invention analyzes which portion is selected for
10 layer-wise printing in order to cut the contours at the start point and end point of the selected portion, the remaining which is filled with the mesh pattern.

Furthermore, whether a wireframe structure or hybrid structure, the invention prints all detail of the same segment. For example, if a segment contains multiple disconnected contours, the invention prints all contours located
15 on the same segment first before moving up to the next segment.

While the disclosure is susceptible to various modifications and alternative forms, specific exemplary embodiments of the invention have been shown by way of example in the drawings and have been described in detail. It should be understood, however, that there is no intent to limit the disclosure to the particular
20 embodiments disclosed, but on the contrary, the intention is to cover all modifications, equivalents, and alternatives falling within the scope of the disclosure as defined by the appended claims.

CLAIMS

1. A method for adapting a printing device for fabrication of a wireframe structure on a surface, the printing device including a print head, the steps comprising of:

5 registering parameters of the printing device, wherein the parameters include an angle of the print head defined from a horizontal axis and a diameter of the print head;

calculating from the angle and the diameter a depth defined along a vertical axis at which the print head deposits a material; and

10 defining a plane at the angle of the print head at which the print head deposits the material, the depth and the plane defining a portion of space viable for printing the wireframe structure on the surface.

2. The method for adapting a printing device for fabrication of a wireframe structure according to claim 1 further comprising the steps of:

receiving a 3D model for fabrication;

converting the 3D model into a vector representation (of one or more points, lines, curves, polygons, etc.);

determining an order for printing segments of the vector representation;

20 creating a 3D representation of the wireframe structure based on the order for printing segments.

3. The method for adapting a printing device for fabrication of a wireframe structure according to claim 2 further comprising the step of:

25 extruding the material from the print head based on the order for printing segments to fabricate the wireframe structure.

4. The method for adapting a printing device for fabrication of a wireframe structure according to claim 2, wherein the step of determining an order of printing segments of the vector representation further comprising the steps of:

slicing the 3D model into segments, each segment defined by a first layer positioned from a second layer at a distance equal to the depth; and

defining a mesh pattern joining the first layer and the second layer, the mesh pattern including a support edge connected to a downward edge, the downward edge limited by the angle of the print head from a horizontal axis.

5 5. The method for adapting a printing device for fabrication of a wireframe structure according to claim 1, wherein the material is Acrylonitrile Butadiene Styrene (ABS).

10 6. The method for adapting a printing device for fabrication of a wireframe structure according to claim 1, wherein the material is Polylactic Acid or Polylactide (PLA).

15 7. The method for adapting a printing device for fabrication of a wireframe structure according to claim 2, wherein the segments are slices along the z-axis forming one or more horizontal slices.

20 8. The method for adapting a printing device for fabrication of a wireframe structure according to claim 2, wherein the segments are slices along the x-axis forming one or more vertical slices.

 9. The method for adapting a printing device for fabrication of a wireframe structure according to claim 3 wherein the extruding step is performed by repeated vertical movement of the print head of the printing device.

25 10. The method for adapting a printing device for fabrication of a wireframe structure according to claim 3, wherein the extruding step further comprising the step of cooling the material to accelerate solidification of the material.

30 11. The method for adapting a printing device for fabrication of a wireframe structure according to claim 3, wherein the wireframe structure includes one or more solid surfaces.

12. A system for fabricating of a wireframe structure on a surface, the system including a processor, a controller and a print head, the system comprising:

5 a processor that executes g-code causing the print head to extrude filament material in the form of a mesh pattern, the mesh pattern determined from one or more parameters of the print head, the one or more parameters including an angle of the print head defined from a horizontal axis and a diameter of the print head.

10 13. The system for fabricating of a wireframe structure on a surface according to claim 12, wherein the mesh pattern comprises a first layer, a second layer, and a downward edge, the first layer and the second layer separated by a distance calculated from the angle of the print head and the diameter of the print head and the downward edge limited by the angle of the print head.

15

14. The system for fabricating of a wireframe structure on a surface according to claim 13, wherein the mesh pattern further comprises a support edge connected to the first layer, the second layer and the downward edge.

20 15. A method for converting a 3D model to a wireframe representation for fabrication by a printing device, comprising the steps of:

slicing the 3D model into one or more segments, each segment defined by a thickness equal or less than a distance a print head of the printing device can descend without colliding with printed material; and

25 defining a mesh pattern to replace one or more surfaces of the 3D model, wherein the mesh pattern is defined to prevent collisions between printed material.

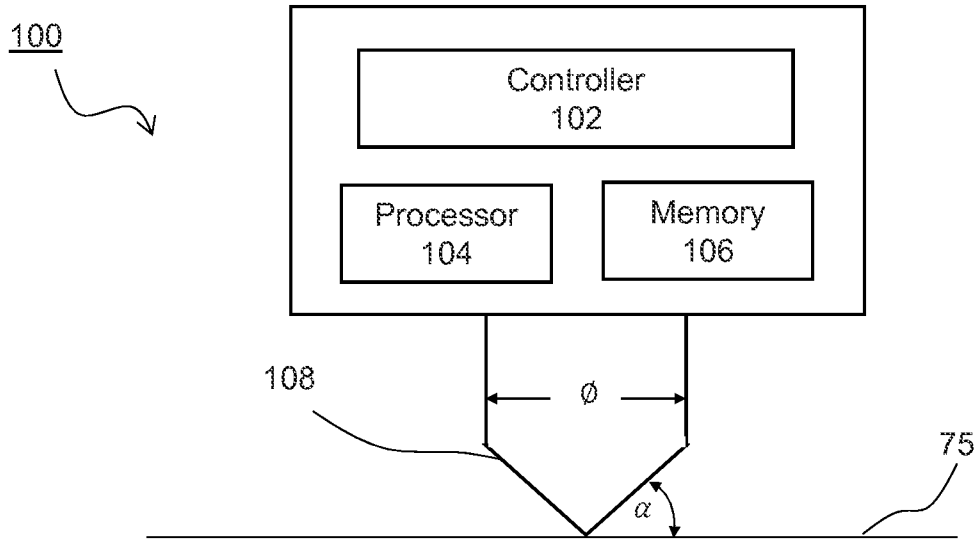

FIG. 1

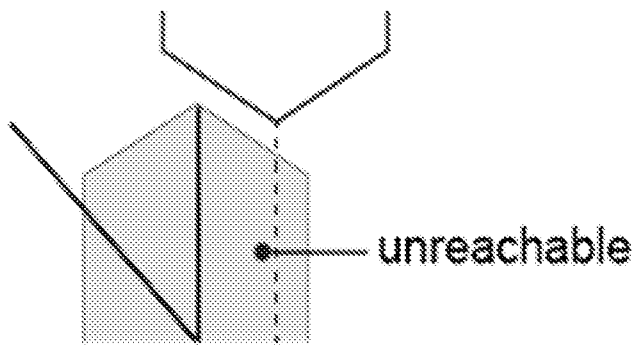

FIG. 2A

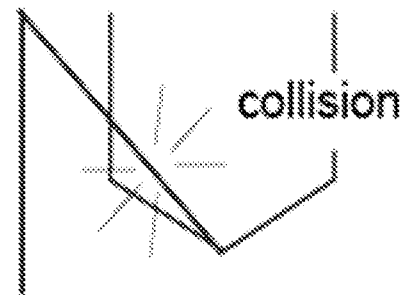
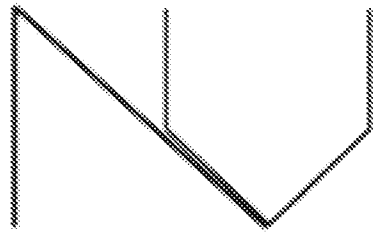
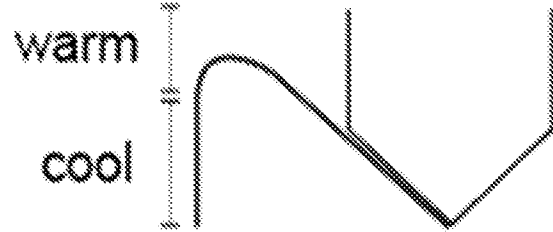

FIG. 2B



intended result

FIG. 3A



bending problem

FIG. 3B

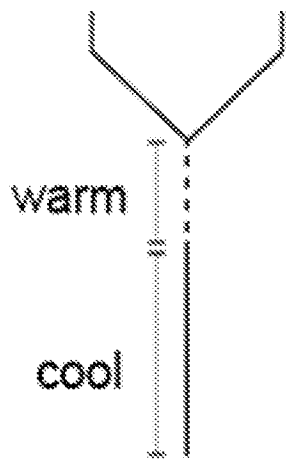

z-compensation

FIG. 4A

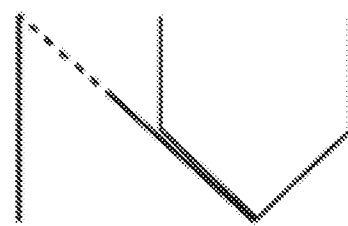

straight result

FIG. 4B

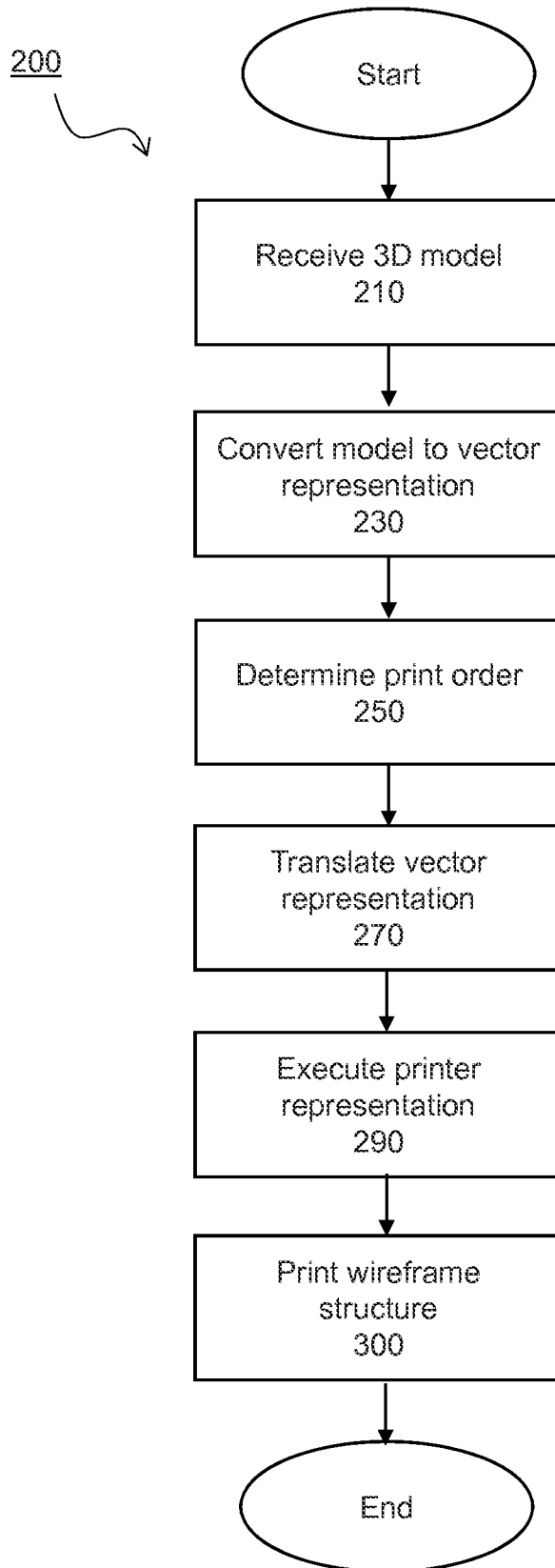

FIG. 5

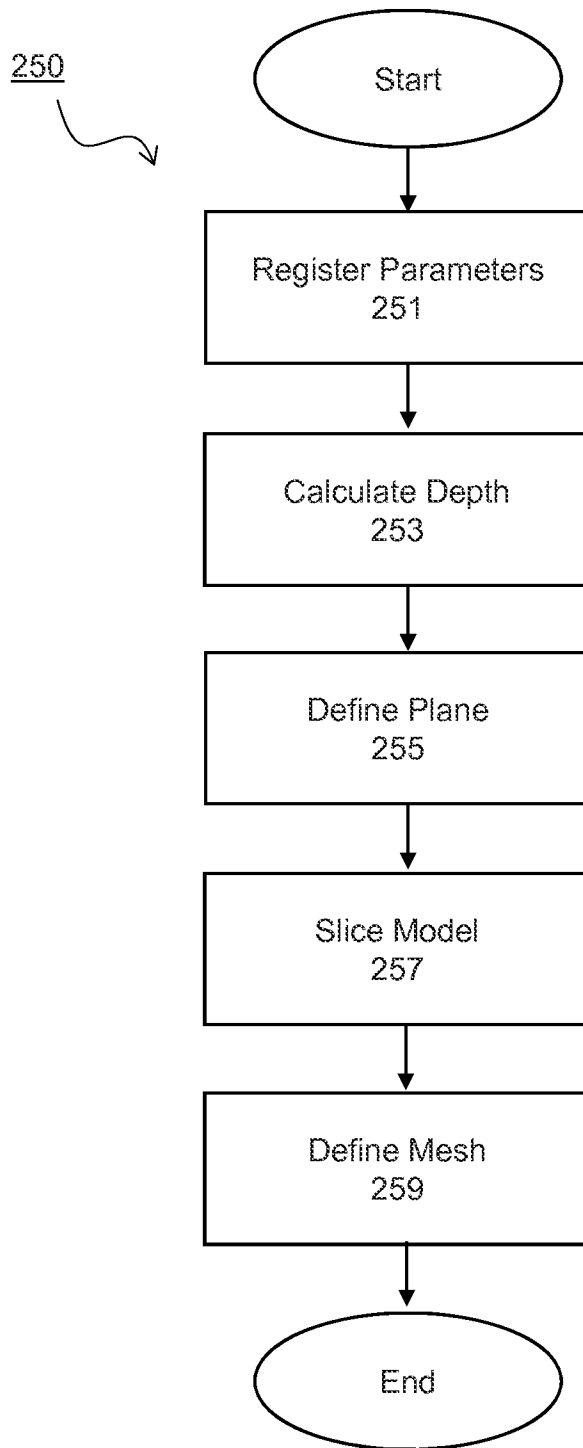

FIG. 6

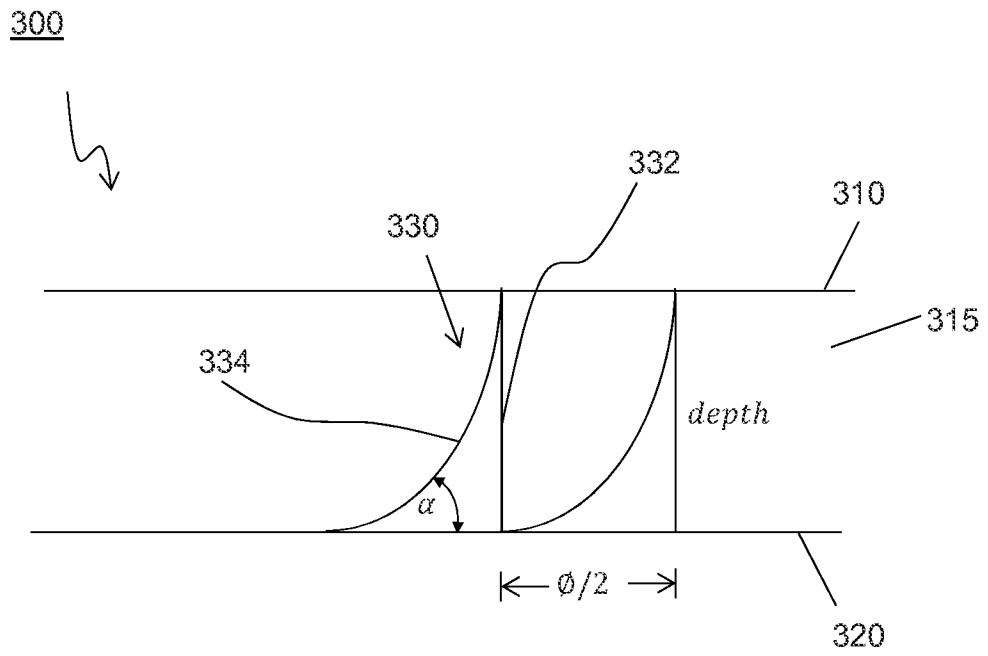

FIG. 7

INTERNATIONAL SEARCH REPORT

International application No. PCT/US 15/49224
--

<p>A. CLASSIFICATION OF SUBJECT MATTER IPC(8) - G06F 19/00 (2016.01) CPC - G06F 17/50 According to International Patent Classification (IPC) or to both national classification and IPC</p>
<p>B. FIELDS SEARCHED</p> <p>Minimum documentation searched (classification system followed by classification symbols) IPC(8): G06F 19/00 (2016.01) CPC: G06F 17/50</p> <p>Documentation searched other than minimum documentation to the extent that such documents are included in the fields searched USPC: 700/98 or 700/97 or 700/182 IPC(8): G06F 19/00 (2016.01) CPC: G06F 17/50 or G06T 19/00 or A61C 13/0004 or G05B 19/4097 or G05B 19/4099</p> <p>Electronic data base consulted during the international search (name of data base and, where practicable, search terms used) Patbase; Google Scholar; mesh, wireframe, printing, printhead, parameters, angle, diameter, depth, filament, extrude, three dimensional, 3D</p>

C. DOCUMENTS CONSIDERED TO BE RELEVANT		
Category*	Citation of document, with indication, where appropriate, of the relevant passages	Relevant to claim No.
Y	US 6,772,026 B2 (Bradbury et al.) 03 August 2004 (03.08.2004) (entire document especially col. 7, ln 15-18; col. 8, ln 59-63; col 11, ln 38-47; col. 15, ln 24-26; col. 16, ln 21-33; col. 26, ln 41 to col. 27, ln 57; col. 28, ln 10-12)	1-14
Y	US 2007/0229497 A1 (Zinniel et al.) 04 October 2007 (04.10.2007) (para [0029]-[0034], [0049])	1-14
Y	US 2004/0166187 A1 (Fong) 26 August 2004 (26.08.2004) (para [0045]-[0049])	10

Further documents are listed in the continuation of Box C.

- | | |
|---|---|
| <p>* Special categories of cited documents:</p> <p>"A" document defining the general state of the art which is not considered to be of particular relevance</p> <p>"E" earlier application or patent but published on or after the international filing date</p> <p>"L" document which may throw doubts on priority claim(s) or which is cited to establish the publication date of another citation or other special reason (as specified)</p> <p>"O" document referring to an oral disclosure, use, exhibition or other means</p> <p>"T" document published prior to the international filing date but later than the priority date claimed</p> | <p>"T" later document published after the international filing date or priority date and not in conflict with the application but cited to understand the principle or theory underlying the invention</p> <p>"X" document of particular relevance; the claimed invention cannot be considered novel or cannot be considered to involve an inventive step when the document is taken alone</p> <p>"Y" document of particular relevance; the claimed invention cannot be considered to involve an inventive step when the document is combined with one or more other such documents, such combination being obvious to a person skilled in the art</p> <p>"&" document member of the same patent family</p> |
|---|---|

Date of the actual completion of the international search 13 January 2016 (13.01.2016)	Date of mailing of the international search report 02 FEB 2016
---	--

Name and mailing address of the ISA/US Mail Stop PCT, Attn: ISA/US, Commissioner for Patents P.O. Box 1450, Alexandria, Virginia 22313-1450 Facsimile No. 571-273-8300	Authorized officer: Lee W. Young PCT Helpdesk: 571-272-4300 PCT OSP: 571-272-7774
---	--

INTERNATIONAL SEARCH REPORT

International application No.

PCT/US 15/49224

Box No. II Observations where certain claims were found unsearchable (Continuation of item 2 of first sheet)

This international search report has not been established in respect of certain claims under Article 17(2)(a) for the following reasons:

- 1. Claims Nos.:
because they relate to subject matter not required to be searched by this Authority, namely:

- 2. Claims Nos.:
because they relate to parts of the international application that do not comply with the prescribed requirements to such an extent that no meaningful international search can be carried out, specifically:

- 3. Claims Nos.:
because they are dependent claims and are not drafted in accordance with the second and third sentences of Rule 6.4(a).

Box No. III Observations where unity of invention is lacking (Continuation of item 3 of first sheet)

This International Searching Authority found multiple inventions in this international application, as follows:

- see extra sheet -

- 1. As all required additional search fees were timely paid by the applicant, this international search report covers all searchable claims.
- 2. As all searchable claims could be searched without effort justifying additional fees, this Authority did not invite payment of additional fees.
- 3. As only some of the required additional search fees were timely paid by the applicant, this international search report covers only those claims for which fees were paid, specifically claims Nos.:
- 4. No required additional search fees were timely paid by the applicant. Consequently, this international search report is restricted to the invention first mentioned in the claims; it is covered by claims Nos.:
1-14

- Remark on Protest**
- The additional search fees were accompanied by the applicant's protest and, where applicable, the payment of a protest fee.
 - The additional search fees were accompanied by the applicant's protest but the applicable protest fee was not paid within the time limit specified in the invitation.
 - No protest accompanied the payment of additional search fees.

Continuation of Box III: Lack of Unity

This application contains the following inventions or groups of inventions which are not so linked as to form a single general inventive concept under PCT Rule 13.1. In order for all inventions to be examined, the appropriate additional examination fees must be paid.

Group I: claims 1-14 are drawn to a method/system for fabricating a wireframe structure on a surface.

Group II: claim 15 are drawn to a method for converting a 3D model to a wireframe representation.

The inventions listed as Groups I through II do not relate to a single general inventive concept under PCT Rule 13.1 because under PCT Rule 13.2 they lack the same or corresponding technical features for the following reasons:

Special Technical Features:

The special technical feature of Group I is a printing device that includes a print head, which uses a calculated registered angle from a horizontal axis and a diameter to deposit the material and uses the defined depth and the plane for printing the wireframe structure on the surface, and extrudes a mesh pattern, not present in any other group.

The special technical feature of Group II is a method including slicing the 3D model into segments and replacing the surface of the 3D model with a mesh pattern in order to prevent colliding, not present in any other group.

Common Technical Feature:

Groups I-II share a technical feature of a fabricating a wireframe structure, a printing device that includes a print head, printed material, and a mesh pattern. However, this shared technical features does not represent a contribution over the prior art:

US 6,772,026 B2 (Bradbury et al.) (hereinafter Bradbury) 03 August 2004 (03.08.2004)

Bradbury teaches fabricating a wireframe structure (e.g. multi-dimensional digital model may take the form of a ...wire-frame representation, col. 8, ln 55-63; e.g. perform a fabrication, a print job must be loaded into the Process Control Software on the target machine, col. 27, ln 50-51), a printing device that includes a print head (e.g. a 3-dimensional printer 69, col. 7, ln 15-16; e.g. Three-dimensional printing (3DP)...a drop-on-demand print head, which may be a piezoelectric print head, or a continuous-jet-with-deflection printhead, col. 15, ln 4-25; col. 16, ln 21-27), printed material (e.g., the use of printing materials, including powder, binder and any subsequent filling, infusing or other processing materials, col. 15, ln 30-34), and a mesh pattern (e.g. the mesh, 506, col. 26, ln 41-48; col. 14, ln 17-20).

Therefore, Groups I - II lack unity under PCT Rule 13 because they do not share a same or corresponding special technical feature.