

(19) (KR)  
(12) (Y1)

(51) 。 Int. Cl. <sup>7</sup> (45) 2002 02 27  
A01K 61/00 (11) 20 - 0266121  
(24) 2002 02 15

(21) 20 - 2001 - 0035844  
(22) 2001 11 21

(73) 184

(72) 184

(74)  
:  
가 :

(54)

(101,102) , (103) (S) (T)가 (101,102)  
(100)가 가 , (104,105)가 (104,105)가  
(106) , (104,105) (B)  
(107) , (104,105) (B)  
(108) (104,105)가 (B)

3

, , , ,

1 ,  
 2 1 ,  
 3 1 ,  
 4 ,  
 5 ,  
 6 ,  
 7 ,  
 8 ,  
 9 .

\*

100 : 101,102 :

103 : 104,105 :

106 : 107 :

108 : 110 :

A : B :

S : T :

가 , , 가 .

(Abalone)

가 , 가 , 가 .



, ' 가 , .

1 , 2 , 3 4

1 4 (T)가 (101,102) (101,102) (103)  
(S) , (101,102)  
(104,105)가 (100)가

(104,105)가 (B) 가 (104,105) (B)  
(106) , (107)

(104,105)가 (B) (108)

5 가 가 (110) (110)  
(110) 가 (A) 가 (103)  
(103)

6 (104,105) 가 1 4 , (101,102)

가

7 , (T)가

, 가

가

가

가

(57)

1.

(103) (S) , (T)가 (101,102) 가  
 (104,105)가 (101,102) (100)가 가

2.

1 ,  
 (104,105)가 (B) (106)

3.

1 ,  
 (104,105) (B) (107)

4.

1 ,  
 (104,105)가 (B) (108)

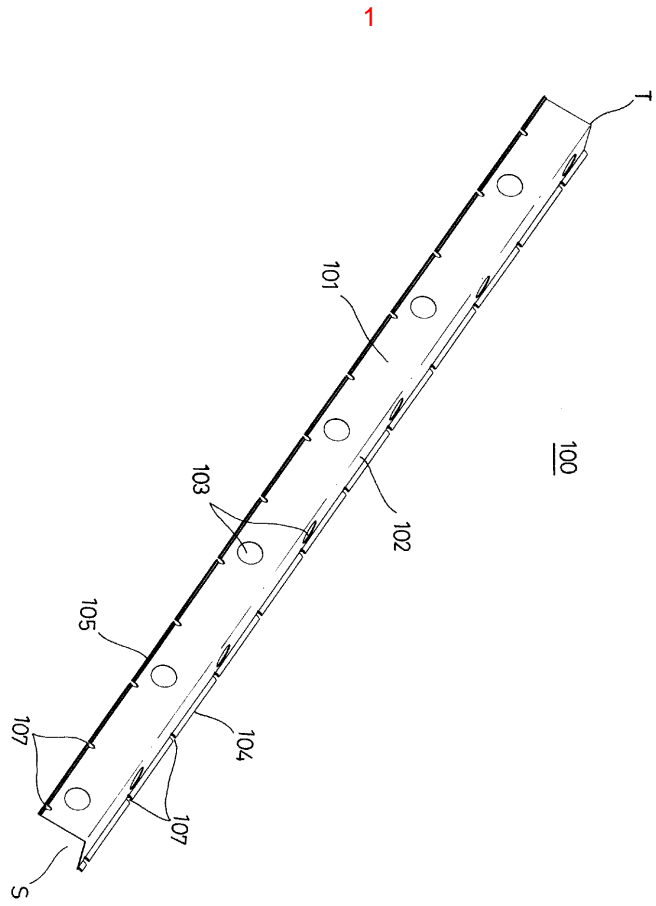



4

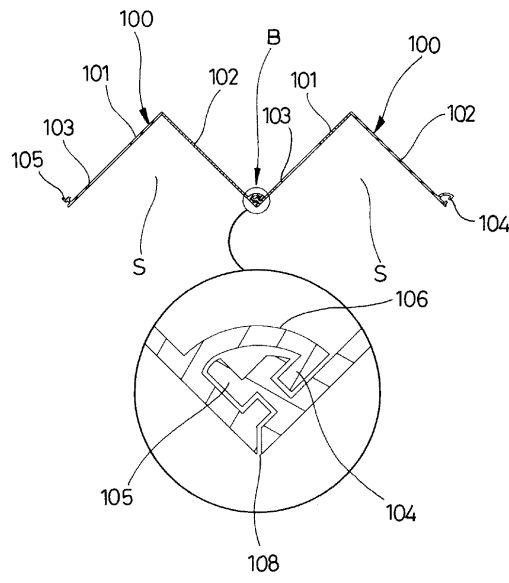

5

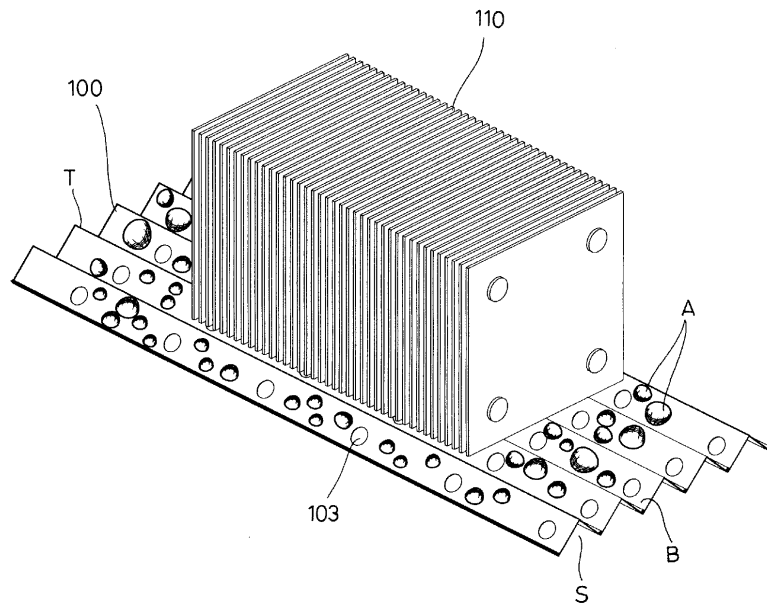



6

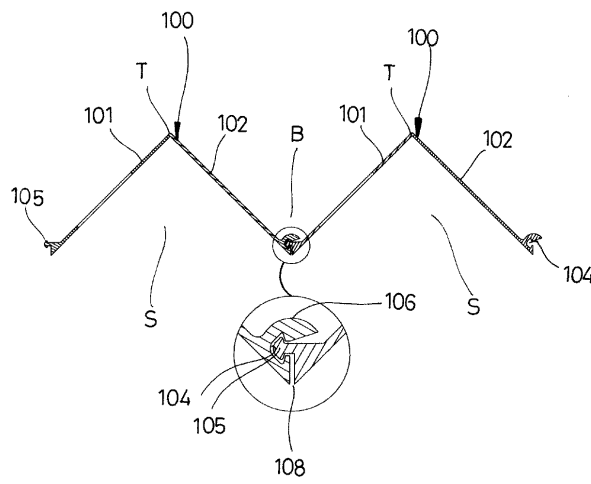

7

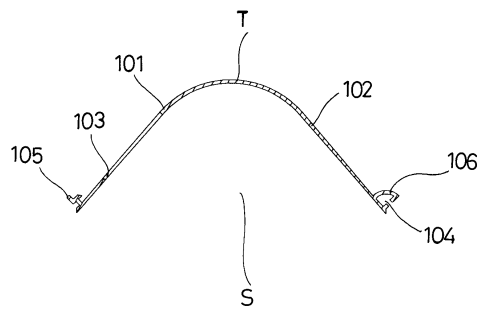

8

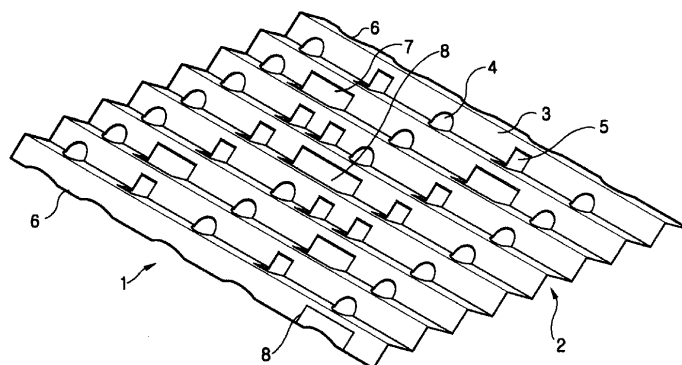

9

