

L. H. MERRIMAN.

MACHINES FOR TRIMMING TENONS ON SPOKES.

No. 182,944.

Patented Oct. 3, 1876.

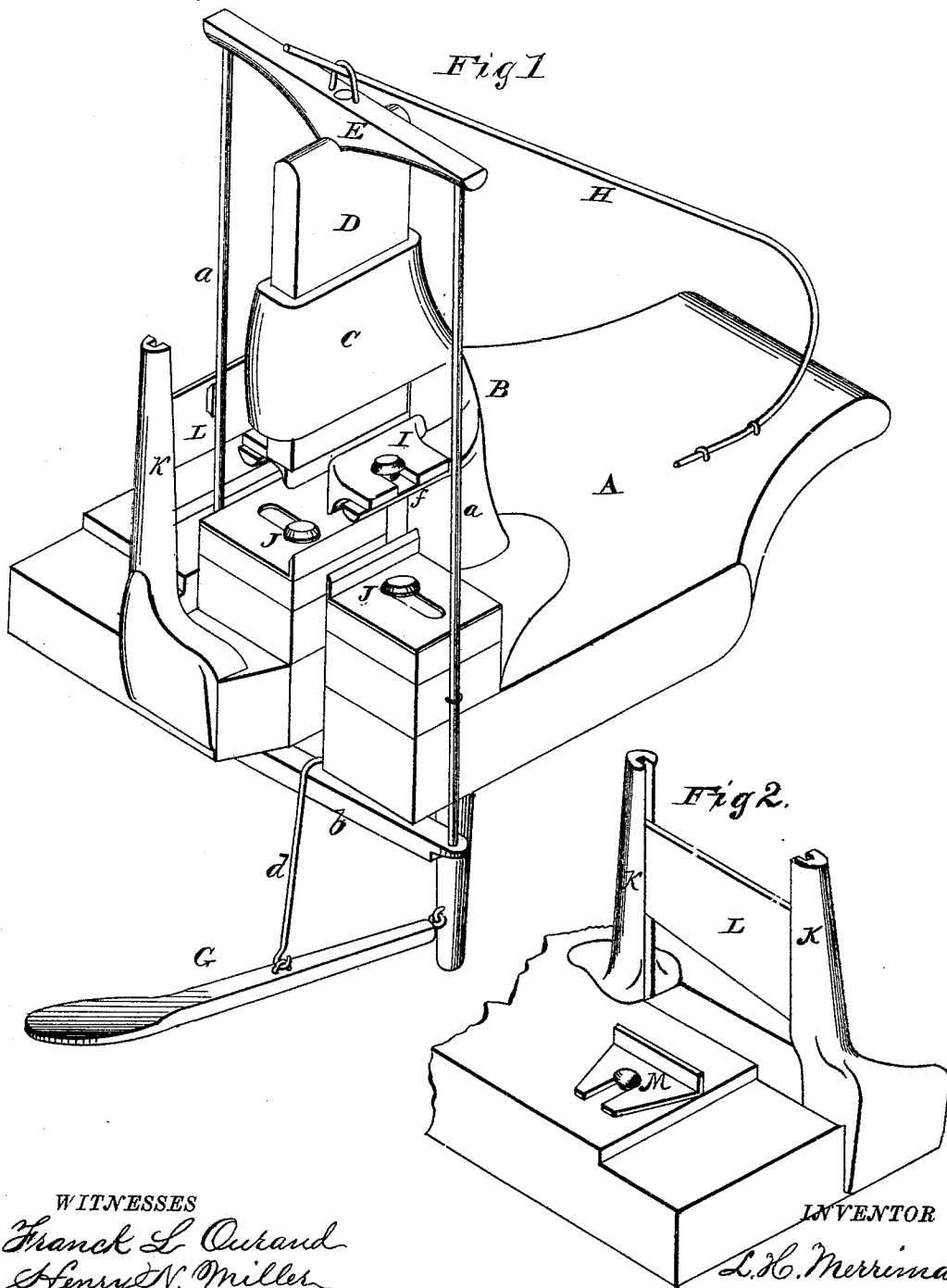

WITNESSES

Frank L. Outard
Henry V. Miller

INVENTOR

L. H. Merriman
By Alexander Mason
Attorneys.

UNITED STATES PATENT OFFICE.

LEMUEL H. MERRIMAN, OF AUBURN, ILLINOIS.

IMPROVEMENT IN MACHINES FOR TRIMMING TENONS ON SPOKES.

Specification forming part of Letters Patent No. **182,944**, dated October 3, 1876; application filed May 13, 1876.

To all whom it may concern:

Be it known that I, L. H. MERRIMAN, of Auburn, in the county of Sangamon and in the State of Illinois, have invented certain new and useful Improvements in Machines for Trimming Tenons on Spokes; and do hereby declare that the following is a full, clear, and exact description thereof, reference being had to the accompanying drawings, and to the letters of reference marked thereon, making a part of this specification.

The nature of my invention consists in the construction and arrangement of a machine for trimming tenons on spokes, as will be hereinafter more fully set forth.

In order to enable others skilled in the art to which my invention appertains to make and use the same, I will now proceed to describe its construction and operation, referring to the annexed drawing, in which—

Figure 1 is a perspective view of my machine. Fig. 2 is a view of a detached part thereof.

A represents the bed-plate of my machine, on which is a standard, B, carrying at its upper end the head C, as shown. Through this head passes the plunger B, which is attached to a top cross-bar, E, and this cross-bar has at its ends pendent rods *a a*, the lower ends of which are under the bed-plate, connected by a cross-bar, *b*. This cross-bar *b* is, by a rod, *d*, connected with a foot lever or treadle, G, by means of which the plunger D is forced downwardly, said plunger being raised again, as soon as the pressure is removed from the treadle by a spring, H, connected to the top cross-bar E.

Below the head C on each side of the standard B is secured an arm, *f*, which carries an adjustable gage, I, which are to bring the spoke to the center between the knives J J below. These knives consist of horizontal plates, with their inner edges turned upward, forming the knives, and are adjustable out and

in so as to regulate them for any required thickness of tenon.

The tenon is forced down between the knives by pressure on the foot lever or treadle G, and is thereby trimmed to the desired thickness.

In operating this machine, the gages I I must first be adjusted to correspond with the knives J J, and the spoke is placed between the gages, when, by pressure on the foot-lever, the plunger D is forced down, pressing the spoke down to and between the knives, the gages I acting as guides for the spoke, so that it must be cut true. The tenons on the spokes are made as usual in the spoke-factories, but they almost invariably have to be dressed down to suit the mortises in the hub, and the common method is to work them down by hand. With my machine, the gages I I are adjusted so as to bring the tenon of the spoke to the center between the knives, and keep it there until it is forced through the knives, and the knives take the same amount off of each side of the tenon.

To one of the rods *a* is secured a wide knife, L, with its edge moving in vertical guides K K for trimming the back of the tenon, said tenon being set to any desired taper by means of an adjustable gage, M.

Having thus fully described my invention, what I claim as new, and desire to secure by Letters Patent, is—

The combination of the adjustable knives J J, adjustable gages I I, the plunger D, operated by the foot-lever G, and the spring H, substantially as and for the purposes herein set forth.

In testimony that I claim the foregoing I have hereunto set my hand this 11th day of April, 1876.

LEMUEL H. MERRIMAN.

Witnesses:

G. W. MURRAY,
W. H. CASSITY.