

Nov. 25, 1969

G. H. GLUNTZ

3,480,904

MOUNTING MEANS FOR AN ELECTRICAL CONNECTOR

Filed Aug. 21, 1967

3 Sheets-Sheet 1

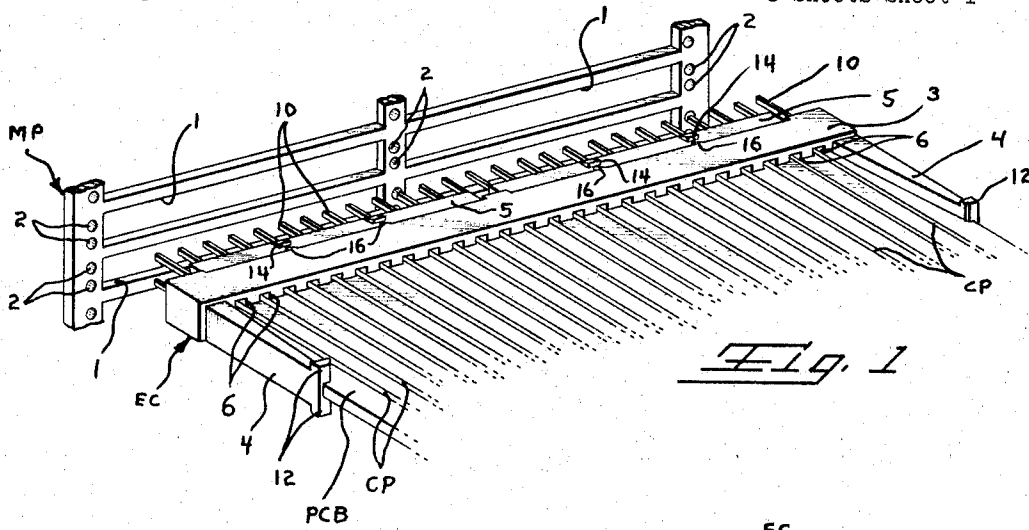

Fig. 1

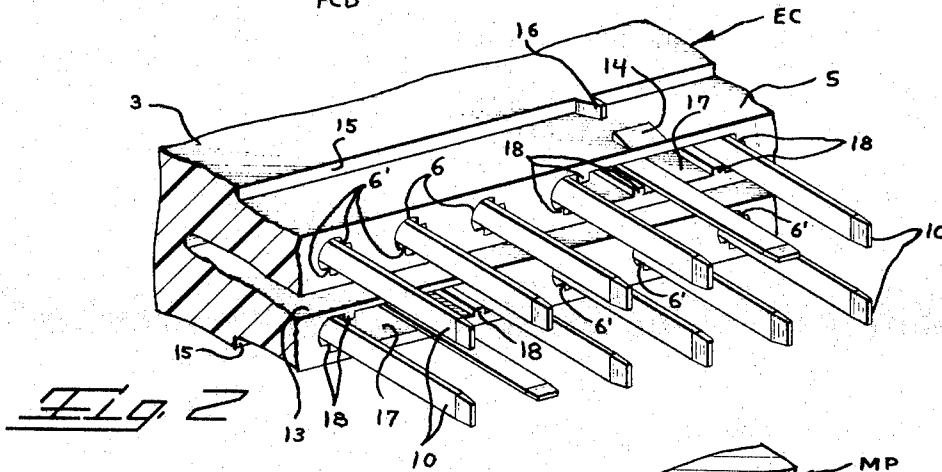

Fig. 2

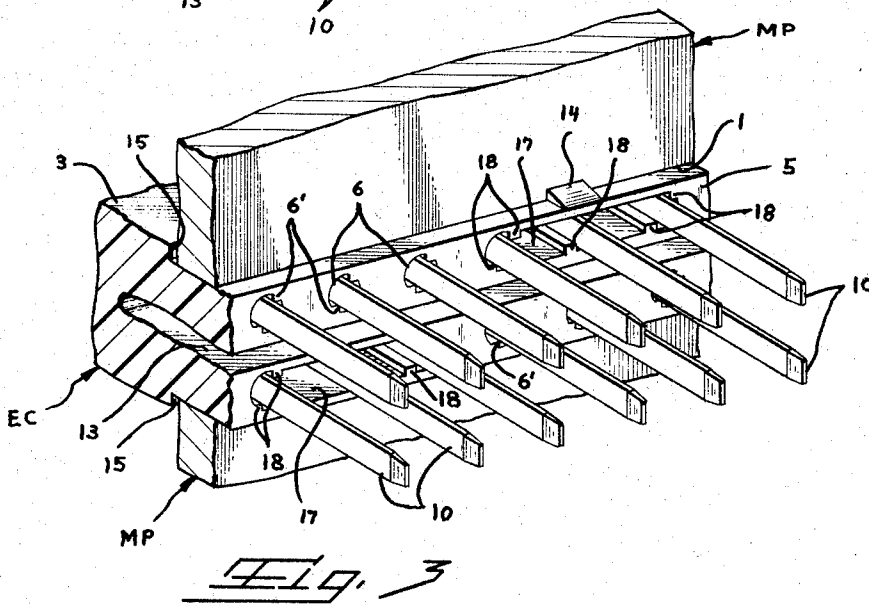

Fig. 3

Nov. 25, 1969

G. H. GLUNTZ

3,480,904

MOUNTING MEANS FOR AN ELECTRICAL CONNECTOR

Filed Aug. 21, 1967

3 Sheets-Sheet 2

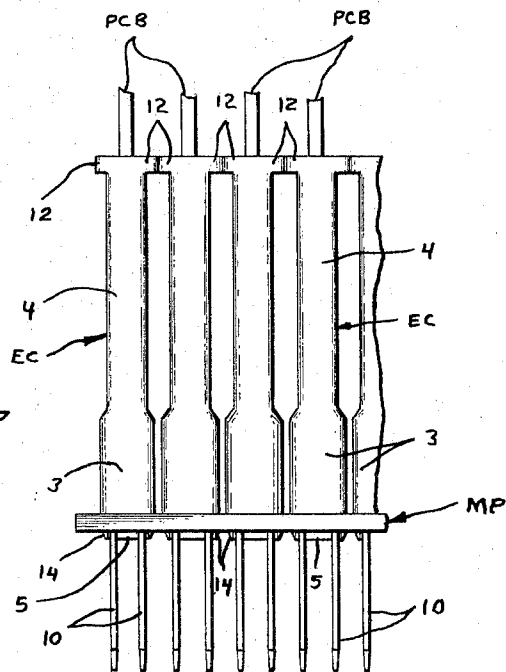
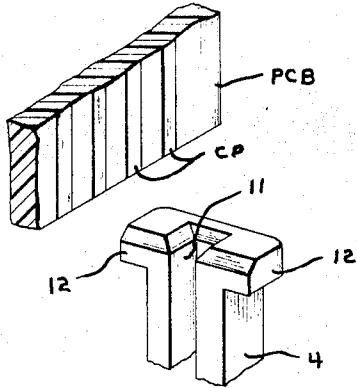
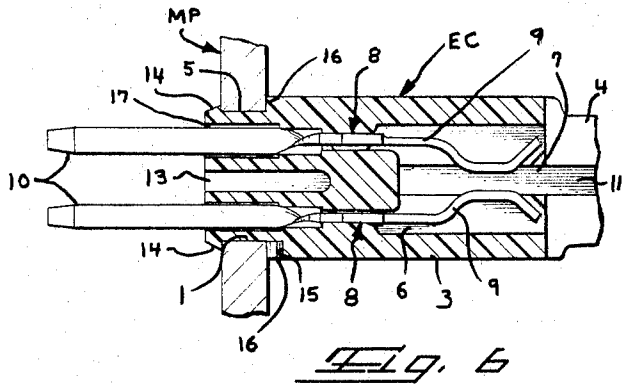
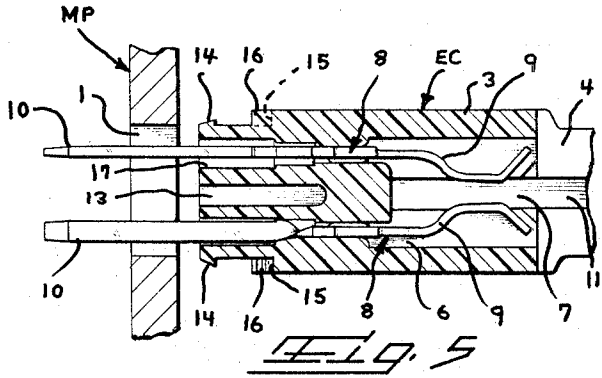
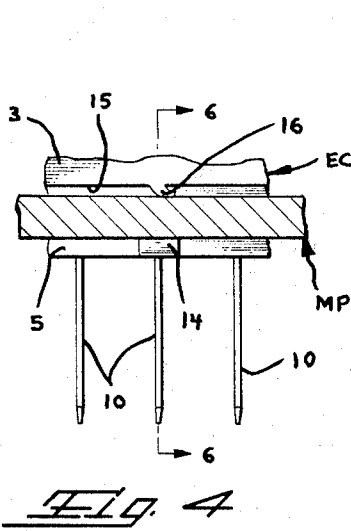

Fig. 7

Fig. 8

Nov. 25, 1969

G. H. GLUNTZ

3,480,904

MOUNTING MEANS FOR AN ELECTRICAL CONNECTOR

Filed Aug. 21, 1967

3 Sheets-Sheet 3

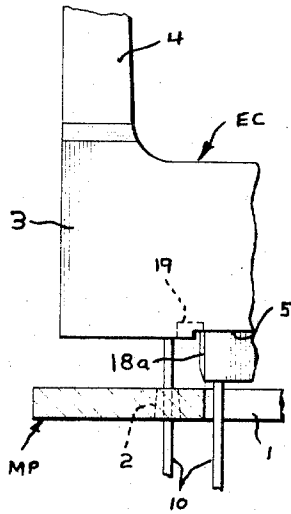

Fig. 9

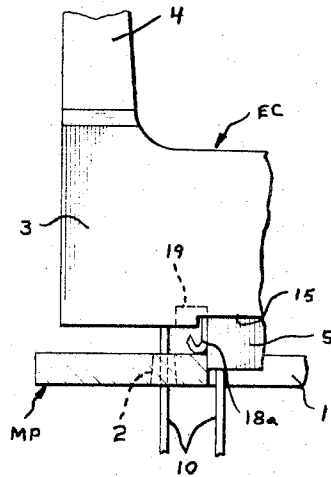

Fig. 10

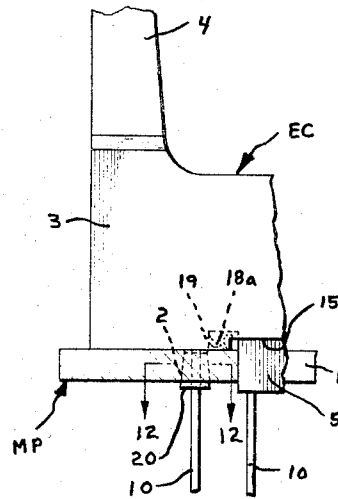

Fig. 11

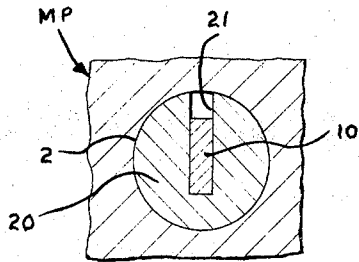

Fig. 12

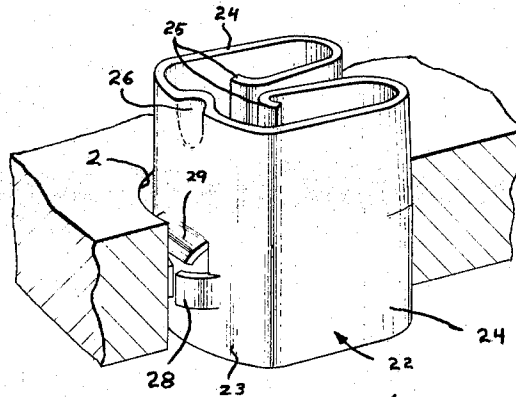

Fig. 13

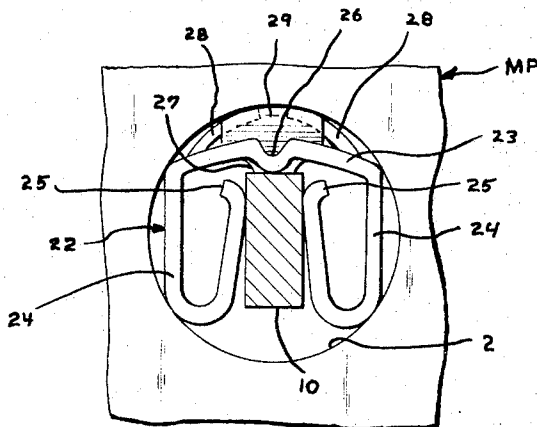

Fig. 14

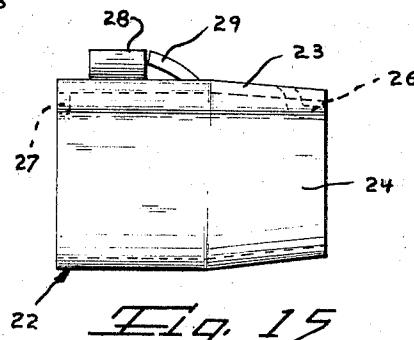

Fig. 15

1

2

3,480,904
MOUNTING MEANS FOR AN ELECTRICAL CONNECTOR

Glenn Harlan Gluntz, Harrisburg, Pa., assignor to
 AMP Incorporated

Filed Aug. 21, 1967, Ser. No. 661,898

Int. Cl. H01r 13/20

U.S. Cl. 339—65

11 Claims

ABSTRACT OF THE DISCLOSURE

An electrical connector mounting arrangement which constitutes a mounting panel having an opening extending therethrough, an electrical connector including a dielectric housing and electrical terminals disposed in passageways in the dielectric housing, the dielectric housing having a protruding section disposed within the opening of the mounting panel and including the terminals provided with sections extending outwardly beyond the protruding section, spaced projections disposed along an exterior surface of the protruding section adjacent an outer end thereof and in engagement with one surface of the mounting panel, and engaging section means provided on the protruding section inwardly from the spaced projections and being directed toward another surface of the mounting panel for limiting movement of the protruding section within the opening. The portions of the protruding section carrying the spaced projections are flexible due to oblong openings to permit the projections to flex during insertion of the protruding section in the panel opening, the sections of the terminals in alignment with the projections being twisted to limit flexure of the portions thereby locking the housing in the panel opening. Means are provided between the engaging section means and the other surface of the mounting panel to take up any play. Means are also provided to effect a ground connection between some of the electrical terminals and the mounting panel.

This invention relates to an electrical connector mounting arrangement for mounting an electrical connector onto a mounting panel and more particularly to a mounting arrangement for mounting a printed circuit connector in an opening of a panel without the use of mounting hardware.

It is known, as disclosed in U.S. Patents 2,911,460, 2,919,300, and 2,995,617, to place a hollow dielectric insert into an opening of a mounting member and to introduce an electrical terminal having an enlarged area into the insert and force the enlarged area into the insert thereby expanding the insert into frictional engagement with the opening to form an interference-fit and securing the terminal in position.

This concept is satisfactory when placing and securing individual terminals in position in a mounting member, but it is not a desirable approach when electrical terminals secured in a dielectric housing are to be disposed in corresponding openings in a mounting panel and secured in at least some of them. Infinite problems would result among which are the following: individual inserts provided for the openings and special configurations provided on the terminals in the areas that are to form the interference-fit of the inserts in the openings.

Another approach to mounting electrical connectors on a mounting panel is that of providing openings to receive the electrical connectors and the electrical connectors are secured to the mounting panel via bolts, rivets, screws and the like as disclosed by U.S. Patents 2,994,056 and 3,084,302. Such an approach requires extra hardware and alignment is generally not proper if point-to-point

wiring is to be automatically applied to the electrical terminals of the electrical connectors.

An object of the present invention is to provide an electrical connector mounting arrangement which obviates the drawbacks of existing mounting arrangements.

Another object of the invention is the provision of a mounting panel having openings therethrough in which sections of a connector housing are disposed and means being provided on the housings securing the connector housings in position in the openings of the mounting panel.

A further object is to provide projections of a connector housing surrounding sections of electrical terminals extending outwardly from the connector housing, these projections mating with corresponding openings in a mounting panel with the projections being provided with securing means to secure the sections in the opening.

An additional object of the invention is the provision of means to take up any play between the housing and the mounting panel so that the housing is prevented from being loosely mounted in position for effective use in connection with automatic point-to-point wiring techniques.

Still a further object of the invention is to provide means to connect some of the electrical terminals to the mounting panel to effect a ground connection therebetween.

Other objects and attainments of the present invention will become apparent to those skilled in the art upon a reading of the following detailed description when taken in conjunction with the drawings in which there is shown and described illustrative embodiments of the invention; it is to be understood, however, that these embodiments are not intended to be exhaustive nor limiting of the invention but are given for purposes of illustration in order that others skilled in the art may fully understand the invention and the principles thereof and the manner of applying it in practical use so that they may modify it in various forms, each as may be best suited to the conditions of a particular use.

In the drawings:

FIGURE 1 is an exploded perspective view of an electrical connector carrying a printed circuit board exploded from a mounting panel;

FIGURE 2 is a perspective view of part of the electrical connector of FIGURE 1;

FIGURE 3 is a view similar to FIGURE 2 illustrating the electrical connector in position in an opening of a mounting panel;

FIGURE 4 is a top plan view of FIGURE 3;

FIGURE 5 is an exploded and cross-sectional view of the electrical connector prior to being mounted in an opening of a mounting panel;

FIGURE 6 is a view taken along lines 6—6 of FIGURE 4;

FIGURE 7 is a perspective exploded view of a detail of the electrical connector with the printed circuit board exploded therefrom;

FIGURE 8 is a side view illustrating the electrical connectors in position in respective openings of mounting panel;

FIGURES 9 through 12 illustrate an aligning feature of the present invention and the connection of an electrical terminal to the mounting panel; and

FIGURES 13—15 illustrate an alternative connection means for connecting an electrical terminal to the mounting panel.

Turning now to the drawings and especially FIGURES 1 through 8, there is illustrated a metallic mounting panel MP having rectangular openings 1 located therein and round openings 2 at the ends of rectangular openings 1.

Electrical connector EC comprises a body section 3 and printed circuit board or card guides 4. Body section 3 has protruding sections 5 that extend outwardly from the rear surface of body section 3. Protruding sections 5 are spaced from each other and are mateable with longitudinally aligned rectangular openings 1 in mounting panel MP.

Passageways 6 extend through body section 3 and protruding sections 5 and through body section 3 at the outer ends of sections 5 and therebetween. Passageways 6 are in communication with channel 7 which is located in body section 3 for receiving a printed circuit board PCB therein.

Electrical terminals 8 are disposed in respective passageways 6 and include contact sections 9 which are disposed in channel 7 so as to be engageable with respective conductive paths CP of printed circuit board PCB when inserted in position within channel 7 of the electrical connector. Electrical terminals 8 also include posts 10 which extend outwardly from the rear surface of the electrical connector for engagement with electrical conductors applied by manual or automatic point-to-point wiring devices. Posts 10 that are to be disposed within round openings 2 do not extend through protruding sections 5 and these will be discussed in greater detail hereinafter.

Card guides 4 are provided with channels 11 in communication with channels 7 to guide printed circuit board PCB thereinto. One of card guides 4 is longer than the other so as to provide polarization and the outer ends of the card guides are provided with lugs 12 so that the lugs of the card guides of one of electrical connectors EC are engageable with the lugs of adjacent electrical connectors to provide stabilization therebetween and also to provide ventilation between the printed circuit boards as illustrated in FIGURE 8 because the thickness of card guides 4 is less than that of body sections 3. Lugs 12 have an appropriate height in order to perform the intended operation. The entrances to channels 11 are beveled as illustrated in FIGURE 7 to facilitate insertion of the printed circuit boards thereinto.

Electrical terminals 8 are preferably secured in passageways 6 by twisting posts 10 relative to contact sections 9 until post 10 engages stops 6' in accordance with the teaching set forth in U.S. patent application, Ser. No. 613,966, filed Feb. 3, 1967 now Patent No. 3,348,191, but, of course, the terminals can be secured in position in the passageways in any desirable manner.

A channel 13 is disposed in body section 3 and protruding sections 5 which forms portions that separate the top row of terminals from the bottom row of terminals and provides ventilation therebetween. Locking projections 14 are disposed along the exterior surfaces of protruding sections 5 at the outer ends thereof and at staggered locations therealong. The upper surface of locking projections 14 is tapered so as to facilitate the insertion of protruding sections 5 within rectangular openings 1. Stepped surfaces 15 are located at the junction between body section 3 and protruding sections 5. Severable projections 16 extend outwardly from stepped surfaces 15 and protruding sections 5 opposite locking projections 14. Projections 16 are wedge-shaped and are disposed at an angle with respect to surfaces 15 and are severable from protruding sections 5 by the edges of openings 1 so as to take up any play between surfaces 15 and the mounting panel when protruding sections 5 are disposed within openings 1 and locking projections 14 engage the rear surface of the mounting panel as illustrated in FIGURE 4.

An oblong opening 17 is located in each part of protruding section 5 beneath locking projections 14 so that a passageway 6 is in alignment with the locking projection 14 and this passageway and passageways on each side thereof are in communication with oblong openings 17. Stops 18 are provided in openings 17 in alignment with respective passageways 6 so that post 10 can be

twisted into engagement therewith to limit the amount of twisting that post 10 will undergo.

In order to insert an electrical connector in openings 1 of mounting panel MP the following procedure is followed. Electrical terminals 8 are placed in respective passageways 6 and posts 10 except those in alignment with locking projections 14 are twisted against stops 6' to secure the electrical terminals in position in the passageways of the electrical connector. Leaving posts 10 of the electrical terminals in the passageways in alignment with locking projections 14 in an untwisted condition, permits the portion of protruding sections 5 on which locking projections 14 are located to be flexible thereby permitting locking projections 14 to be flexed inwardly during insertion of protruding sections 5 within openings 1 of the mounting panel thereby facilitating insertion of the protruding sections within these openings. With protruding sections 5 in position within openings 1, locking projections 14 engage the rear surface of mounting panel MP and severable projections 16 are severable from protruding sections 5 if the thickness of mounting panel MP is such as to cause severing of projections 16 and projections 16 engage the front surface of mounting panel MP to take up any play thereby tightly securing the electrical connector in position on the mounting panel. After the protruding sections 5 have been positioned within openings 1, posts 10 in alignment with locking projections 14 are then twisted into engagement with stops 18 as illustrated in FIGURES 3, 4, and 6 thereby preventing the portions of protruding sections 5 carrying locking projections 14 from flexing very far inwardly which locks the protruding sections in position in opening 1 of the mounting panel.

Due to the fact that channel 13 is disposed in protruding sections 5, all of posts 10 of the electrical terminals are twisted into position against the stops in the passageways and the oblong openings and the protruding sections are forcefully pushed into respective openings 1 of the mounting panel. Channel 13 permits the portions of protruding sections 5 carrying the rows of terminal posts to move toward each other thereby permitting locking projections 14 to be inserted within openings 1 and then move outwardly toward their normal positions to perform their locking functions after they have cleared the openings.

FIGURES 9 through 12 illustrate a feature for aligning the electrical connector in the opening of the mounting member and an additional feature for grounding certain electrical terminals. A projection 18a is located at the end of one of protruding sections 5 and it includes a beveled surface at its outer end. A recess 19 is disposed in body section 3 in alignment with projection 18a. As protruding section 5 is driven into opening 1, the end edge of opening 1 engages projection 18a and shears it back and forces the electrical connector toward the other end of the opening and aligning it therewith. The excess of projection 18a that is sheared off is collected in recess 19 in order to prevent any part of the sheared off portion of projection 18a to be disposed between the mounting panel and the electrical connector thereby precluding any obstruction therebetween. The rest of the electrical connectors are mounted in a similar manner and all are therefore aligned along the same end of the openings thereby rendering posts 10 more susceptible to automatic point-to-point wiring devices.

As was mentioned hereinbefore, posts 10 that extend through round openings 2 are to be connected to the mounting panel and they are engaged by a grounding plug 20 thereby effecting a ground connection. Openings 2 are tapered, as illustrated in FIGURE 9 through 11, and the exterior surface of grounding plug 20 is also tapered so as to be mateable therewith. Grounding plug 20 is provided with a slot 21, as illustrated in FIGURE 12, in which post 10 is disposed. After the electrical connector has been secured in openings 1, grounding plugs 20 are

inserted from the rear surface of the mounting panel so that posts 10 are disposed in slots 21 and an impact tool (not shown) is used to drive grounding plugs 20 within the tapered openings 2 causing slot 21 to be decreased thereby snugly and tightly engaging posts 10 to effect an electrical connection therebetween and to stabilize the post in position therein. The sharp edges of slots 21 of the grounding plugs bite into the tapered openings and breaks down any oxide coating therebetween to effect an excellent electrical connection. Plugs 20 are of proper length so as not to extend clear through the mounting panel.

FIGURE 13 through 15 illustrate an alternative connection means for connecting posts of the electrical terminals to the mounting panel. The connection means includes a grounding clip 22 which is stamped and formed and comprises a base 23 having U-shaped legs 24 extending outwardly from opposing sides thereof. The inner members of legs 24 define springable post-engaging members and free ends 25 thereof curve toward the outer members of legs proximate base 23. The leading end of base 23 is provided with an inwardly-directed detent 26 and the trailing end of base 23 is provided with an inwardly-directed tab 27 in alignment with detent 26. Arcuate lugs 28 extend outwardly from base 28 as well as arcuate projection 29 which is disposed forwardly of lugs 28. As can be discerned from FIGURE 15, grounding clip 22 is tapered from projection 29 to the leading end thereof.

In assembly, grounding clips 22 are mounted on posts 10 that are to be disposed in round openings 2 of mounting panel MP, whereby the springable post-engaging members of legs 24 engage posts 10 and detents 26 and tabs 27 define locating means to properly locate the grounding clips thereon as illustrated in FIGURE 14. Grounding clips 22 are therefore driven into position within respective openings 2 as sections 5 of the electrical connector are secured in openings 1 of the mounting panel. The tapered leading ends of the grounding clips facilitate the insertion of the grounding clips in openings 2 and arcuate projections 29 facilitate entry of lugs 28 within the openings. As the sections of clips 22 carrying arcuate lugs 28 and arcuate projections 29 are being driven into openings 2, legs 24 are forced inwardly so that post-engaging members thereof wipingly engage posts 10 and arcuate lugs 28 and arcuate projections 29 provide compensating means to compensate for any tolerance variation of openings 2. The sharp edges of arcuate lugs 28 and arcuate projections 29 also scrape the surfaces of openings 2 to break down any oxide coating that may be present therein to effect an excellent electrical connection. The forces applied onto posts 10 by the post-engaging member of legs 24 and arcuate lugs 28 and arcuate projections 29 are equally distributed at points disposed at equal angular locations passing through the axis of openings 2. As can be discerned from FIGURE 14, grounding clip 22 centrally locates posts 10 in openings 2 as well as forming an electrical connection between mounting panel MP and posts 10 in addition to stabilizing posts 10 within openings 2.

It will, therefore, be appreciated that the aforementioned and other desirable objects have been achieved; however, it should be emphasized that the particular embodiments of the invention, which are shown and described herein, are intended as merely illustrative and not as restrictive of the invention.

The invention is claimed in accordance with the following:

1. An electrical connector mounting arrangement comprising a mounting panel having at least one opening extending therethrough, an electrical connector including a dielectric housing and electrical terminals disposed in passageways in the housing, said dielectric housing having a protruding section fitted into the opening, said terminals having conductor-engaging members extending through said protruding section and outwardly therefrom, spaced projections disposed along an exterior surface of said protruding section adjacent an outer end

thereof and in engagement with one surface of the mounting panel, surface means provided on said housing inwardly from said spaced projections and being directed toward another surface of said mounting panel, and means extending outwardly from said surface means and along said protruding section and in engagement with said other surface to take up any play therebetween.

2. An electrical connector mounting arrangement according to claim 1 wherein said take-up means comprises severable projections extending outwardly from said protruding section and said surface means which are severed by edges of said opening.

3. An electrical connector for mounting on a mounting panel and for electrical connection with conductive paths of a printed circuit board, said electrical connector comprising a body section having a mounting section for mounting on a mounting panel and electrical terminals disposed in passageways, said body section being provided with a channel in communication with said passageways, said terminals having contact sections extending into said channel for electrical engagement with respective conductive paths of the printed circuit board, integral guide means extending outwardly from a surface of said body section and having guide channels in communication with said channel to guide the printed circuit board within said channel, and lugs adjacent outer ends of said guide means for engagement with lugs of guide means of a similar electrical connector mounted on the mounting panel to stabilize the electrical connectors.

4. An electrical connector according to claim 3 wherein said lugs of adjacent electrical connectors provide when in engagement spaces to permit ventilation.

5. An electrical connector according to claim 3 wherein one of said guide means is longer than the other of said guide means to provide polarization.

6. An electrical connector for mounting in an opening of a mounting panel comprising a dielectric housing having a protruding section fittable into the opening and passageways extending therethrough, electrical terminals disposed in said passageways and provided with conductor-engaging members in said protruding section and extending outwardly therefrom, spaced projections disposed along parallel exterior surfaces of said protruding section adjacent an outer end thereof for engagement with one surface of the mounting panel, stepped surfaces on said housing inwardly from said projections for disposition toward another surface of the mounting panel, said protruding section having oblong openings inwardly from said projections and in communication with some of said passageways, said oblong openings providing parts of said protruding section on which said projections are carried, said parts being flexible to allow said projections to flex inwardly so as to move through the opening and to move outwardly to engage the one surface of the mounting panel when the protruding section is positioned in the panel opening, said conductor-engaging members in alignment with said projections adapted to be twisted into a position extending across said oblong openings thereby preventing said flexible parts from flexing very far inwardly so that said projections lock said connector in the panel opening.

7. An electrical connector according to claim 6 wherein said protruding section includes another projection along one end which is severable by an edge of the opening to move and maintain said housing toward one end of the opening.

8. An electrical connector according to claim 6 wherein means are provided between said stepped surfaces and the other surface of the mounting panel to take up any play therebetween after said protruding section has been placed in the opening.

9. An electrical connector according to claim 6 wherein guide means provided with guide channels extend integrally outwardly from said housing.

10. An electrical connector according to claim 6 wherein some of said conductor-engaging members are extendable through additional openings in the mounting

panel adjacent the opening and grounding means are engageable with the additional openings and said conductor-engaging members therein to connect same to the mounting panel.

11. An electrical connector for mounting in an opening of a mounting panel comprising a dielectric housing having a protruding section adapted to be fitted into the panel opening and passageway means extending there-through, electrical terminal means disposed in said passageway means and having conductor-engaging means in said protruding section and extending outwardly therefrom, projection means disposed along exterior surfaces of said protruding section adjacent an outer end thereof for engagement with one surface of the mounting panel and stepped surfaces on said housing inwardly from said projection means for disposition toward another surface of the mounting panel when said protruding section is positioned within the panel, said protruding section having oblong opening means inwardly from said projection means and in communication with part of said passageway means, said oblong opening means providing part means of said protruding section on which said projection means is carried, said part means being flexible to allow said projection means to flex inwardly so as to move through the panel opening and to move outwardly to engage the one surface of the mounting panel when said protruding section is positioned in the panel opening, said conductor-engaging means being in alignment with said

projection means adapted to be twisted into a position extending across said oblong opening means thereby preventing said flexible part means from flexing very far inwardly so that said projection means lock said connector in the panel opening.

References Cited

UNITED STATES PATENTS

2,820,209	1/1958	Whitted	339—125
2,891,103	6/1959	Swengel	174—153
2,946,033	7/1960	Wirth	339—17
3,116,960	1/1964	Olsson et al.	339—128
3,179,738	4/1965	DeLyon	339—128
3,246,279	4/1966	Strocel	339—17
3,289,145	11/1966	Ruchlemann et al.	339—176
3,320,607	5/1967	Rueger	339—221
3,328,749	6/1967	Kukla	339—221
3,329,926	7/1967	Aksu	339—17 X
3,334,325	8/1967	Conrad et al.	339—14
3,337,833	8/1967	Creedon	39—14
3,348,191	10/1967	Kinkaid	339—176
3,391,375	7/1968	Richards	339—17
3,399,372	8/1968	Uberbacher	339—14

MARVIN A. CHAMPION, Primary Examiner

U.S. Cl. X.R.

339—14, 128, 176