



US00D899541S

(12) **United States Design Patent**  
**Desberg**

(10) **Patent No.:** **US D899,541 S**

(45) **Date of Patent:** **\*\* Oct. 20, 2020**

- (54) **TWO WHEELED BOARD**
- (71) Applicant: **RAZOR USA LLC**, Cerritos, CA (US)
- (72) Inventor: **Ian Desberg**, Cerritos, CA (US)
- (73) Assignee: **RAZOR USA LLC**, Cerritos, CA (US)
- (\*\*) Term: **15 Years**
- (21) Appl. No.: **29/710,762**
- (22) Filed: **Oct. 25, 2019**

4,151,892 A 5/1979 Francken  
 4,281,734 A 8/1981 Johnston  
 4,325,565 A 4/1982 Winchell  
 (Continued)

**FOREIGN PATENT DOCUMENTS**

CA 2903571 A1 12/2015  
 CN 101148184 A 3/2008  
 (Continued)

**OTHER PUBLICATIONS**

Alex Banks, Everything You Need to Know About the Hoverboard Craze, Highsnobiety.com, Oct. 14, 2015, <http://www.highsnobiety.com/2015/10/14/hoverboard-history>.  
 (Continued)

**Related U.S. Application Data**

- (63) Continuation of application No. 29/674,365, filed on Dec. 20, 2018, now Pat. No. Des. 865,890, which is a continuation of application No. 29/631,901, filed on Jan. 3, 2018, now Pat. No. Des. 837,323, which is a continuation of application No. 29/571,693, filed on Jul. 20, 2016, now Pat. No. Des. 807,457.

- (51) **LOC (12) CL.** ..... **21-02**
- (52) **U.S. CL.**  
USPC ..... **D21/763**

- (58) **Field of Classification Search**  
USPC ..... D21/419, 421, 423, 426, 760, 765, 766, D21/769, 771, 776, 803; D12/1  
CPC ..... A63C 17/01; A63C 17/12; A63C 2203/00; A63C 2203/011; A63C 2203/012; A63C 2203/013; A63C 2203/40; A63C 2203/52; B62D 51/02; B62K 2202/00; B62K 2207/00; B62K 2207/02; B62K 2207/04  
See application file for complete search history.

- (56) **References Cited**

**U.S. PATENT DOCUMENTS**

3,860,264 A 1/1975 Douglas et al.  
 4,065,146 A 12/1977 Denzer  
 4,076,270 A 2/1978 Winchell

*Primary Examiner* — Cynthia M. Chin  
 (74) *Attorney, Agent, or Firm* — Knobbe, Martens, Olson & Bear, LLP

- (57) **CLAIM**  
The ornamental design for a two wheeled board, as shown and described.

**DESCRIPTION**

FIG. 1 is a front, top, left-side perspective view of a two wheeled board of my design;  
 FIG. 2 is a rear, bottom, left-side perspective view thereof;  
 FIG. 3 is a top view thereof;  
 FIG. 4 is a bottom view thereof;  
 FIG. 5 is a front view thereof;  
 FIG. 6 is a rear view thereof;  
 FIG. 7 is a left-side view thereof; and,  
 FIG. 8 is a right-side view thereof.  
 The broken lines illustrate portions of the two wheeled board that form no part of the claim. The dash-dot broken lines immediately adjacent the shaded areas represent the bounds of the claim. None of the broken lines form a part of the claimed design.

**1 Claim, 7 Drawing Sheets**

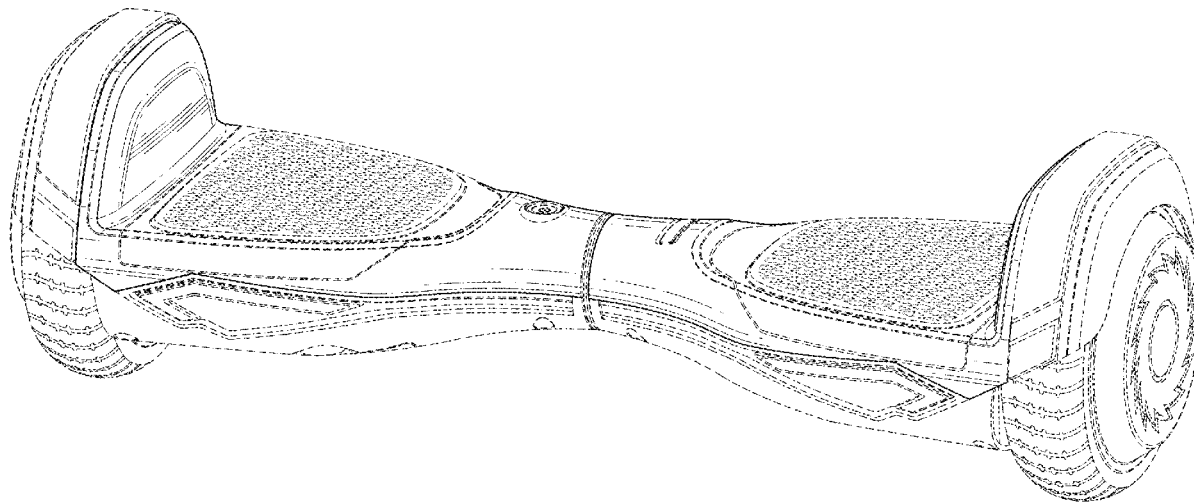

(56)

## References Cited

## U.S. PATENT DOCUMENTS

|           |    |         |                   |           |    |         |                      |
|-----------|----|---------|-------------------|-----------|----|---------|----------------------|
| 4,354,569 | A  | 10/1982 | Eichholz          | 7,004,271 | B1 | 2/2006  | Kamen et al.         |
| 4,484,648 | A  | 11/1984 | Jephcott          | 7,006,901 | B2 | 2/2006  | Wang                 |
| 4,556,997 | A  | 12/1985 | Takamiya et al.   | 7,017,686 | B2 | 3/2006  | Kamen et al.         |
| 4,624,469 | A  | 11/1986 | Bourne, Jr.       | 7,023,330 | B2 | 4/2006  | Kamen et al.         |
| 4,712,806 | A  | 12/1987 | Patrin            | 7,090,040 | B2 | 8/2006  | Kamen et al.         |
| 4,874,055 | A  | 10/1989 | Beer              | 7,091,724 | B2 | 8/2006  | Heinzmann et al.     |
| 5,011,171 | A  | 4/1991  | Cook              | D528,468  | S  | 9/2006  | Arling et al.        |
| 5,165,711 | A  | 11/1992 | Tsai              | 7,130,702 | B2 | 10/2006 | Morrell              |
| D355,148  | S  | 2/1995  | Orsolini          | 7,131,706 | B2 | 11/2006 | Kamen et al.         |
| 5,522,568 | A  | 6/1996  | Kamen et al.      | 7,157,875 | B2 | 1/2007  | Kamen et al.         |
| 5,571,892 | A  | 11/1996 | Fuji et al.       | 7,174,976 | B2 | 2/2007  | Kamen et al.         |
| 5,695,021 | A  | 12/1997 | Schaffner et al.  | 7,178,614 | B2 | 2/2007  | Ishii                |
| 5,701,965 | A  | 12/1997 | Kamen et al.      | 7,182,166 | B2 | 2/2007  | Gray et al.          |
| 5,701,968 | A  | 12/1997 | Wright-Ott et al. | 7,210,544 | B2 | 5/2007  | Kamen et al.         |
| 5,775,452 | A  | 7/1998  | Patmont           | 7,243,572 | B1 | 7/2007  | Arling et al.        |
| 5,791,425 | A  | 8/1998  | Kamen et al.      | 7,263,453 | B1 | 8/2007  | Gansler et al.       |
| 5,794,730 | A  | 8/1998  | Kamen             | D551,592  | S  | 9/2007  | Chang et al.         |
| 5,848,660 | A  | 12/1998 | McGreen           | D551,722  | S  | 9/2007  | Chang et al.         |
| 5,971,091 | A  | 10/1999 | Kamen et al.      | 7,273,116 | B2 | 9/2007  | Kamen et al.         |
| 5,975,225 | A  | 11/1999 | Kamen et al.      | 7,275,607 | B2 | 10/2007 | Kamen et al.         |
| 6,050,357 | A  | 4/2000  | Staelin et al.    | 7,303,032 | B2 | 12/2007 | Kahlert et al.       |
| 6,052,647 | A  | 4/2000  | Parkinson et al.  | 7,338,056 | B2 | 3/2008  | Chen et al.          |
| 6,062,600 | A  | 5/2000  | Kamen et al.      | 7,357,202 | B2 | 4/2008  | Kamen et al.         |
| 6,223,104 | B1 | 4/2001  | Kamen et al.      | 7,363,993 | B2 | 4/2008  | Ishii                |
| D444,184  | S  | 6/2001  | Kettler           | 7,367,572 | B2 | 5/2008  | Jiang                |
| 6,273,212 | B1 | 8/2001  | Husted et al.     | 7,370,713 | B1 | 5/2008  | Kamen                |
| 6,288,505 | B1 | 9/2001  | Heinzmann et al.  | 7,407,175 | B2 | 8/2008  | Kamen et al.         |
| 6,302,230 | B1 | 10/2001 | Kamen et al.      | 7,437,202 | B2 | 10/2008 | Morrell              |
| 6,332,103 | B1 | 12/2001 | Stenson et al.    | 7,469,760 | B2 | 12/2008 | Kamen et al.         |
| 6,357,544 | B1 | 3/2002  | Kamen et al.      | 7,479,872 | B2 | 1/2009  | Kamen et al.         |
| 6,367,817 | B1 | 4/2002  | Kamen et al.      | 7,481,291 | B2 | 1/2009  | Nishikawa            |
| 6,386,576 | B1 | 5/2002  | Kamen et al.      | 7,546,889 | B2 | 6/2009  | Kamen et al.         |
| 6,405,816 | B1 | 6/2002  | Kamen et al.      | 7,592,900 | B2 | 9/2009  | Kamen et al.         |
| 6,408,240 | B1 | 6/2002  | Morrell et al.    | D601,922  | S  | 10/2009 | Imai et al.          |
| 6,415,879 | B2 | 7/2002  | Kamen et al.      | 7,690,447 | B2 | 4/2010  | Kamen et al.         |
| 6,435,535 | B1 | 8/2002  | Field et al.      | 7,690,452 | B2 | 4/2010  | Kamen et al.         |
| 6,443,250 | B1 | 9/2002  | Kamen et al.      | 7,703,568 | B2 | 4/2010  | Ishii                |
| 6,538,411 | B1 | 3/2003  | Field et al.      | 7,708,094 | B2 | 5/2010  | Kamen et al.         |
| 6,543,564 | B1 | 4/2003  | Kamen et al.      | 7,740,099 | B2 | 6/2010  | Field et al.         |
| 6,547,026 | B2 | 4/2003  | Kamen et al.      | 7,757,794 | B2 | 7/2010  | Heinzmann            |
| 6,553,271 | B1 | 4/2003  | Morrell           | 7,779,939 | B2 | 8/2010  | Kamen et al.         |
| 6,561,294 | B1 | 5/2003  | Kamen et al.      | 7,783,392 | B2 | 8/2010  | Oikawa               |
| 6,575,539 | B2 | 6/2003  | Reich             | 7,789,174 | B2 | 9/2010  | Kamen et al.         |
| 6,581,714 | B1 | 6/2003  | Kamen et al.      | 7,812,715 | B2 | 10/2010 | Kamen et al.         |
| 6,598,941 | B2 | 7/2003  | Field et al.      | 7,857,088 | B2 | 12/2010 | Field et al.         |
| 6,651,763 | B1 | 11/2003 | Kamen et al.      | 7,900,725 | B2 | 3/2011  | Heinzmann et al.     |
| 6,651,766 | B2 | 11/2003 | Kamen et al.      | 7,938,207 | B2 | 5/2011  | Kamen et al.         |
| D489,027  | S  | 4/2004  | Waters            | 7,950,123 | B2 | 5/2011  | Arling et al.        |
| D489,029  | S  | 4/2004  | Waters            | 7,962,256 | B2 | 6/2011  | Sterns et al.        |
| 6,715,845 | B2 | 4/2004  | Kamen et al.      | 7,979,179 | B2 | 7/2011  | Gansler              |
| D489,300  | S  | 5/2004  | Chang et al.      | 8,014,923 | B2 | 9/2011  | Ishii et al.         |
| D493,127  | S  | 7/2004  | Waters et al.     | 8,028,777 | B2 | 10/2011 | Kakinuma et al.      |
| D493,128  | S  | 7/2004  | Waters et al.     | 8,047,556 | B2 | 11/2011 | Jang et al.          |
| D493,129  | S  | 7/2004  | Waters et al.     | 8,074,388 | B2 | 12/2011 | Trainer              |
| D493,392  | S  | 7/2004  | Waters et al.     | 8,091,672 | B2 | 1/2012  | Gutsch et al.        |
| D494,099  | S  | 8/2004  | Maurer et al.     | 8,146,696 | B2 | 4/2012  | Kaufman              |
| 6,779,621 | B2 | 8/2004  | Kamen et al.      | 8,162,089 | B2 | 4/2012  | Shaw                 |
| 6,789,640 | B1 | 9/2004  | Arling et al.     | 8,170,780 | B2 | 5/2012  | Field et al.         |
| 6,796,396 | B2 | 9/2004  | Kamen et al.      | 8,186,462 | B2 | 5/2012  | Kamen et al.         |
| 6,799,649 | B2 | 10/2004 | Kamen et al.      | 8,225,891 | B2 | 7/2012  | Takenaka et al.      |
| 6,815,919 | B2 | 11/2004 | Field et al.      | 8,248,222 | B2 | 8/2012  | Kamen et al.         |
| 6,827,163 | B2 | 12/2004 | Amsbury et al.    | 8,322,477 | B2 | 12/2012 | Kamen et al.         |
| 6,837,327 | B2 | 1/2005  | Heinzmann         | 8,417,404 | B2 | 4/2013  | Yen et al.           |
| 6,866,107 | B2 | 3/2005  | Heinzmann et al.  | 8,453,340 | B2 | 6/2013  | Van der Merwe et al. |
| 6,868,931 | B2 | 3/2005  | Morrell et al.    | 8,453,768 | B2 | 6/2013  | Kamen et al.         |
| 6,874,591 | B2 | 4/2005  | Morrell et al.    | 8,467,941 | B2 | 6/2013  | Field et al.         |
| 6,889,784 | B2 | 5/2005  | Troll             | 8,490,723 | B2 | 7/2013  | Heinzmann et al.     |
| 6,907,949 | B1 | 6/2005  | Wang              | 8,532,877 | B2 | 9/2013  | Oikawa               |
| D507,206  | S  | 7/2005  | Wang              | 8,584,782 | B2 | 11/2013 | Chen                 |
| 6,920,947 | B2 | 7/2005  | Kamen et al.      | 8,684,123 | B2 | 4/2014  | Chen                 |
| 6,929,080 | B2 | 8/2005  | Kamen et al.      | 8,688,303 | B2 | 4/2014  | Stevens et al.       |
| 6,965,206 | B2 | 11/2005 | Kamen et al.      | 8,738,278 | B2 | 5/2014  | Chen                 |
| 6,969,079 | B2 | 11/2005 | Kamen et al.      | 8,807,250 | B2 | 8/2014  | Chen                 |
| 6,992,452 | B1 | 1/2006  | Sachs et al.      | 8,830,048 | B2 | 9/2014  | Kamen et al.         |
| 7,000,933 | B2 | 2/2006  | Arling et al.     | 8,860,362 | B2 | 10/2014 | Kamen et al.         |
|           |    |         |                   | 8,978,791 | B2 | 3/2015  | Ha et al.            |
|           |    |         |                   | 9,045,190 | B2 | 6/2015  | Chen                 |
|           |    |         |                   | D737,723  | S  | 9/2015  | Ying et al.          |
|           |    |         |                   | D738,256  | S  | 9/2015  | Ying et al.          |



(56)

## References Cited

## FOREIGN PATENT DOCUMENTS

|    |                |    |         |
|----|----------------|----|---------|
| CN | 205186322      | U  | 4/2016  |
| CN | 105539664      | A  | 5/2016  |
| CN | 105539665      | A  | 5/2016  |
| CN | 105539666      | A  | 5/2016  |
| CN | 105539695      | A  | 5/2016  |
| CN | 205469471      | U  | 8/2016  |
| DE | 3411489        |    | 10/1984 |
| DE | 44 04 594      |    | 8/1995  |
| DE | 10209093       |    | 9/2003  |
| DE | 202014010564   | U1 | 1/2016  |
| EP | 2987712        | A1 | 2/2016  |
| GB | 2529565        | A  | 2/2016  |
| JP | 52-044933      |    | 4/1977  |
| JP | 57-87766       |    | 6/1982  |
| JP | 57-110569      |    | 7/1982  |
| JP | 59-73372       |    | 4/1984  |
| JP | 61-31685       |    | 2/1986  |
| JP | 62-12810       |    | 1/1987  |
| JP | 63-305082      |    | 6/1987  |
| JP | 2-190277       |    | 7/1990  |
| JP | 4-201793       |    | 7/1992  |
| JP | 5-213240       |    | 8/1993  |
| JP | 6-105415       |    | 4/1994  |
| JP | 6-171562       |    | 6/1994  |
| JP | 10-023613      |    | 1/1998  |
| JP | H03-070015     |    | 5/2000  |
| JP | 2006-001384    | A  | 1/2006  |
| JP | 2010-254216    | A  | 11/2010 |
| TW | M516550        | U  | 2/2016  |
| TW | M531423        | U  | 11/2016 |
| WO | WO 86/05752    |    | 10/1986 |
| WO | WO 89/06117    |    | 7/1989  |
| WO | WO 96/23478    |    | 8/1996  |
| WO | WO 98/46474    |    | 10/1998 |
| WO | WO 00/75001    |    | 12/2000 |
| WO | WO 2003/68342  |    | 2/2003  |
| WO | WO 2004/07264  |    | 1/2004  |
| WO | WO 2015/188599 |    | 12/2015 |
| WO | WO 2017/092163 |    | 8/2017  |

## OTHER PUBLICATIONS

John D. Bash, How Do Self Balancing Scooters Work?, Bestelectrichoverboard.com (Nov. 12, 2015), <https://bestelectrichoverboard.com/hoverboard-faq/how-do-selfbalancing-scooters-work/>.

Blankespoor et al., Experimental Verification of the Dynamic Model for a Quarter Size Self-Balancing Wheelchair, Proceeding of the 2004 American Control Conference, Boston, MA, vol. 1, pp. 488-492.

CNET, Screenshots of "First look at the Razor Hovertrax 2.0 with Jake Krol" video, posted on Jul. 13, 2016, in 28 pages.

Ben Detrick, Celebrities on Scooters (Catch Them If You Can), The New York Times Aug. 15, 2015, [http://www.nytimes.com/2015/08/16/fashion/cara-delevingne-justinbieber-meek-mill-stephen-curry-on-scooters.html?\\_r=%200](http://www.nytimes.com/2015/08/16/fashion/cara-delevingne-justinbieber-meek-mill-stephen-curry-on-scooters.html?_r=%200).

Hu et al., Self-balancing Control and Manipulation of a Glove Puppet Robot on a Two-Wheel Mobile Platform, 2009 IEEE/RSJ International Conference on Intelligent Robots and Systems, St. Louis, MO, 2009, pp. 424-425.

IO Hawk—Intelligent Personal Mobility Device, <https://web.archive.org/web/20150718144409/http://iohawk.com>, Jul. 18, 2015, in 9 pages.

Inventist, Inc. "Hovertrax Guide and Manual," 2014, in 15 pages. "Inventist Inc , Solo Wheel , Orbit wheel @ Toy Fair 2013" <https://www.youtube.com/watch?v=w8rHKCjLAWI>, Feb. 10, 2013. Alex Kantrowitz, Everything You Need to Know About the Hoverboard Craze, Buzzfeed.com Aug. 27, 2015, [https://www.buzzfeed.com/alexkantrowitz/a-crash-course-inhoverboards?utm\\_term=.qW5Z9x47Z#.oc1W1v56W](https://www.buzzfeed.com/alexkantrowitz/a-crash-course-inhoverboards?utm_term=.qW5Z9x47Z#.oc1W1v56W).

Kawaji, S., Stabilization of Unicycle Using Spinning Motion, Denki Gakkai Ronbunshi, D, vol. 107, Issue 1, Japan (1987), pp. 21-28. Kickstarter, Comments on Hovertrax by Inventist, <https://www.kickstarter.com/projects/687658339/hovertax/comments>, apparently available Oct. 2014, in 16 pages.

Kickstarter, "Hovertrax by Inventist," <https://web.archive.org/web/20130504083823/http://kickstarter.com/projects/687658339/hovertax?>, May 4, 2013, in 11 pages.

Kim et al., Development of a Two-Wheeled Mobile Tilting & Balancing (MTB) Robot, 2011 11th International Conference on Control, Automation and Systems (ICCAS), Gyeonggi-do, 2011, pp. 1-6.

Li et al., A coaxial couple wheeled equilibrium robot with T-S fuzzy equilibrium control, Industrial Robot: An International Journal, vol. 38, Issue 3, pp. 292-300, 2011.

Mike Murphy, Everything You've Ever Wanted to Know About the Hoverboard Craze, Quartz Nov. 11, 2015, <http://qz.com/495935/everything-youve-ever-wanted-to-know-about-the-hoverboard-craze/>.

Mandy Robinson, Hoverboard Black Friday Sales: Best Places to Get One Before Christmas, Inquisitr.com, Nov. 24, 2015, <http://www.inquisitr.com/2589773/hoverboard-black-friday-sales-best-10107994-iv-places-to-get-one-before-christmas/>.

Sasaki et al., Forward and Backward Motion Control of Personal Riding-type Wheeled Mobile Platform, Proceedings of the 2004 IEEE International Conference on Robotics and Automation, vol. 4, pp. 3331-3336.

Sasaki, Makiko et al., "Steering Control of the Personal Riding-type Wheeled Mobile Platform (PMP)," vol. 4 of 4, IEEE, RSJ International Conference on Intelligent Robots and Systems, Aug. 2-6, 2005, in 60 pages.

Schoonwinkel, A, Design and Test of a Computer-Stabilized Unicycle, Stanford University (1988), UMI Dissertation Services.

SINO US Times, Interview of Mr. Ying, <http://www.chic-robot.com/index.php/news/info/54>, Jan. 26, 2016, in 15 pages.

Tsai et al., Development of a Self-Balancing Human Transportation Vehicle for the Teaching of Feedback Control, IEEE Transactions on Education, vol. 52, No. 1, Feb. 2009.

Vos, D., Dynamics and Nonlinear Adaptive Control of an Autonomous Unicycle, Massachusetts Institute of Technology, 1989.

Vos, D., Nonlinear Control of an Autonomous Unicycle Robot: Practical Issues, Massachusetts Institute of Technology, 1992.

Georgia Wells, What It's Like to Have Wheels for Feet: Test Driving the Latest 'Hoverboards', The Wall Street Journal (Oct. 28, 2015), <http://www.wsj.com/articles/what-its-like-to-have-wheels-forfeet-test-driving-the-latest-hoverboards-1446055640>.

Yu et al., Development of a Omni-directional Self-Balancing Robot Wheelchair, Journal of Korea Robotics Society, vol. 8, Iss. 4, pp. 229-237 (2013).

"They're Completely Different Products": IO Hawk President John Soibatian Not Concerned About Infringing Hovertrax Patent, Hoverguru.com (2015), <http://hoverguru.com/posts/theyrecompletely-different-products-io-hawk-president-john-soibatian-notconcerned-about-infringing-on-hovertrax-patent/> (last visited Dec. 27, 2016).

\* cited by examiner

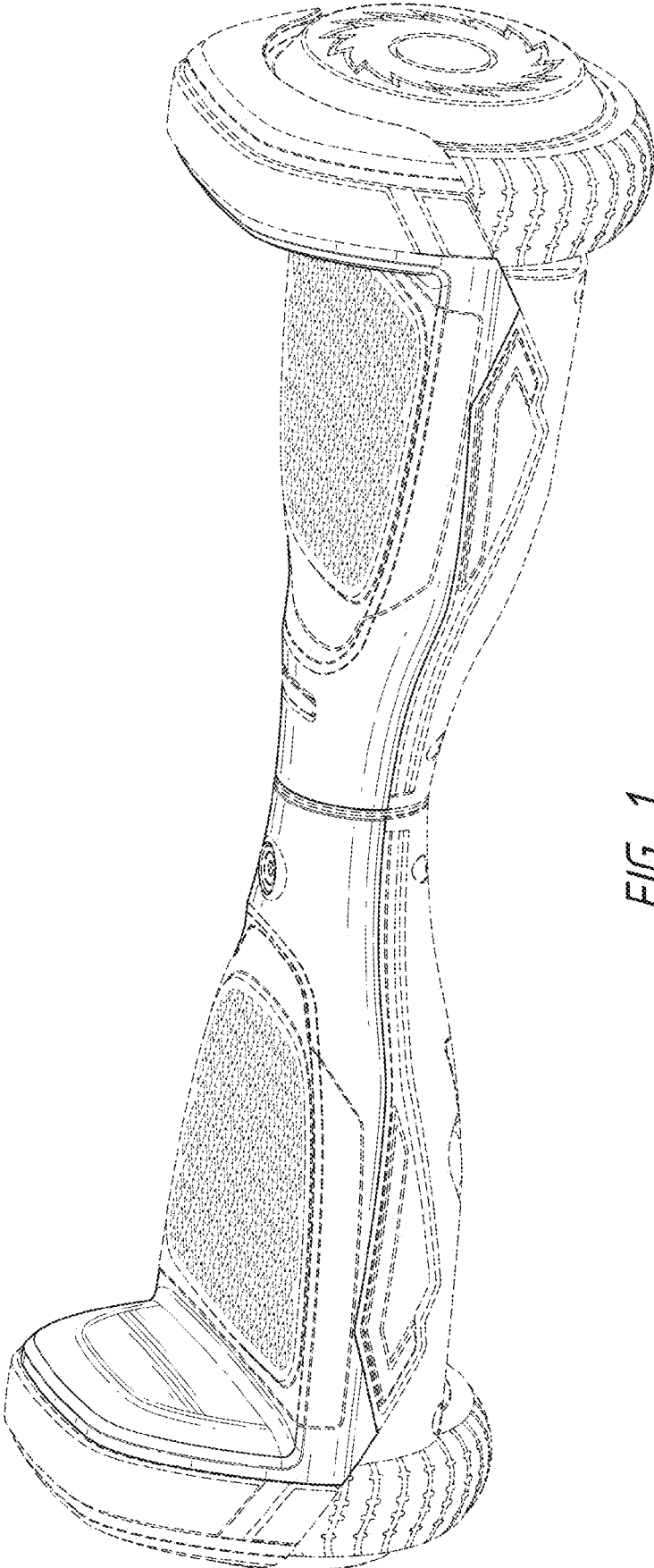

FIG. 1

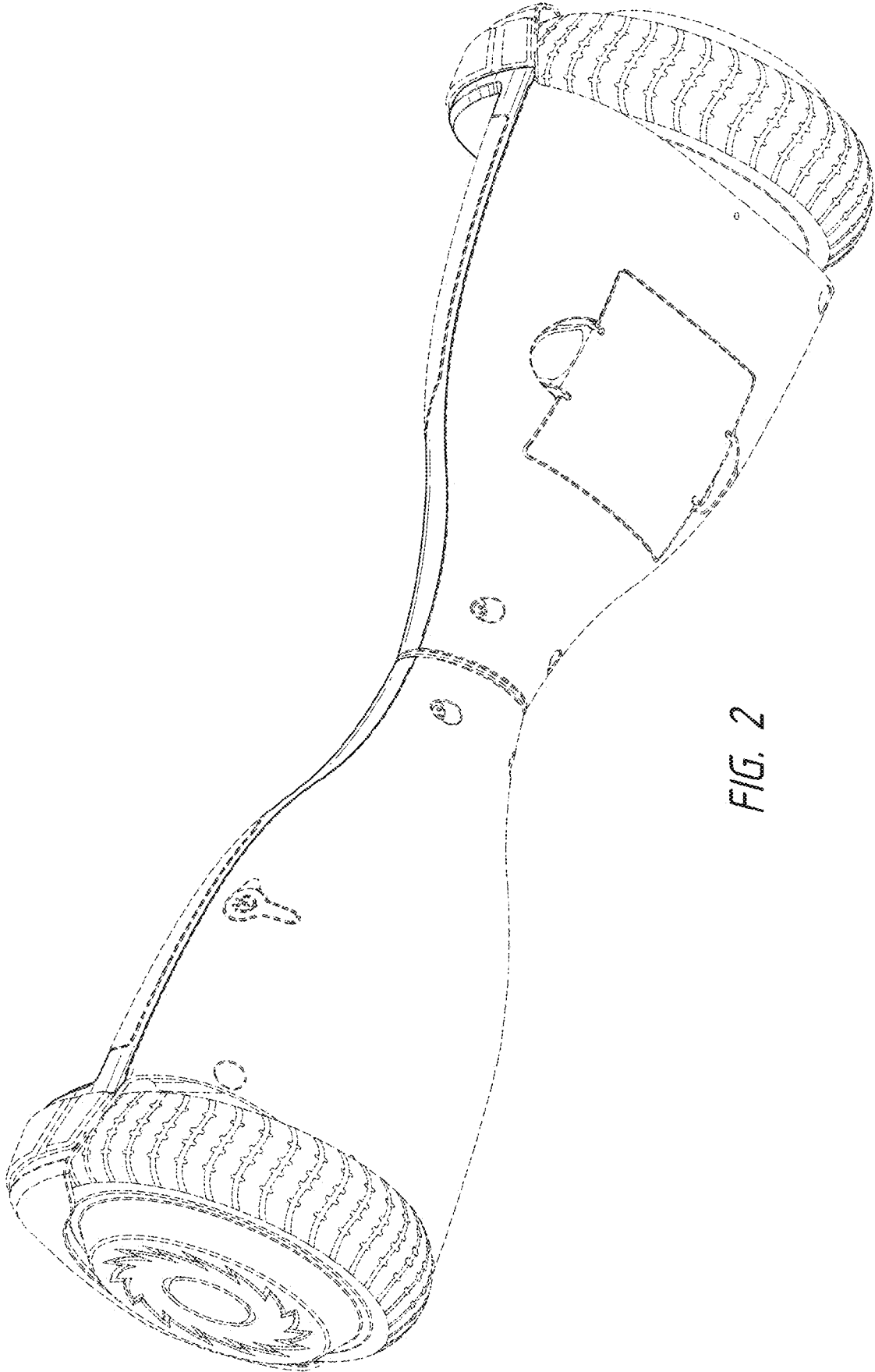

FIG. 2

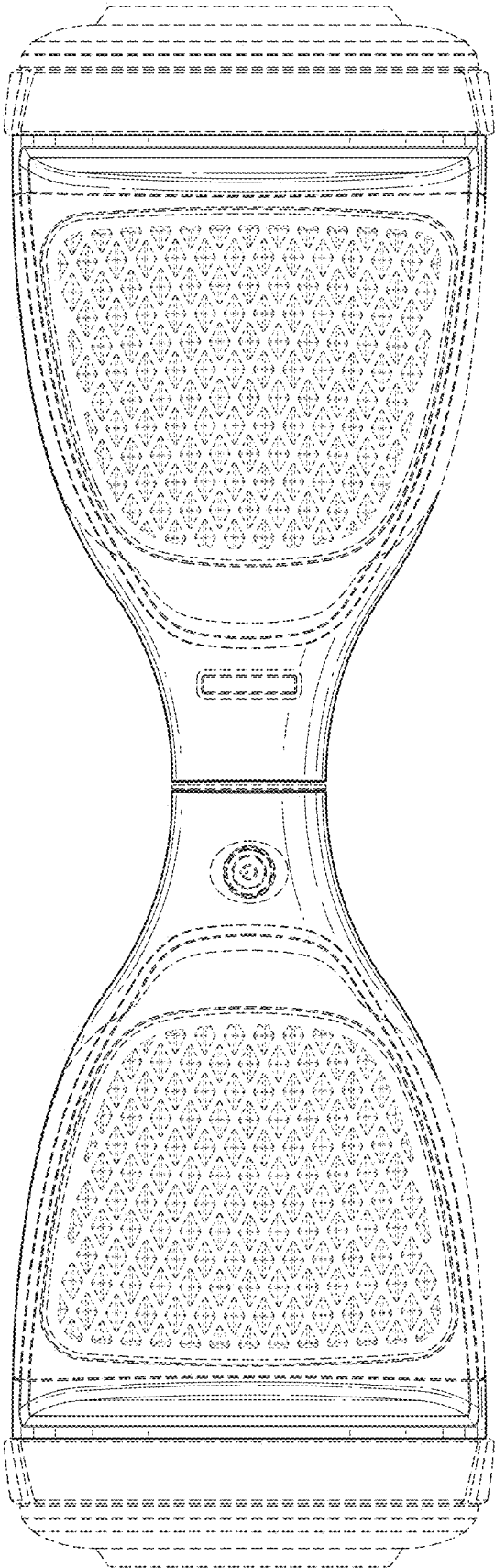

FIG. 3

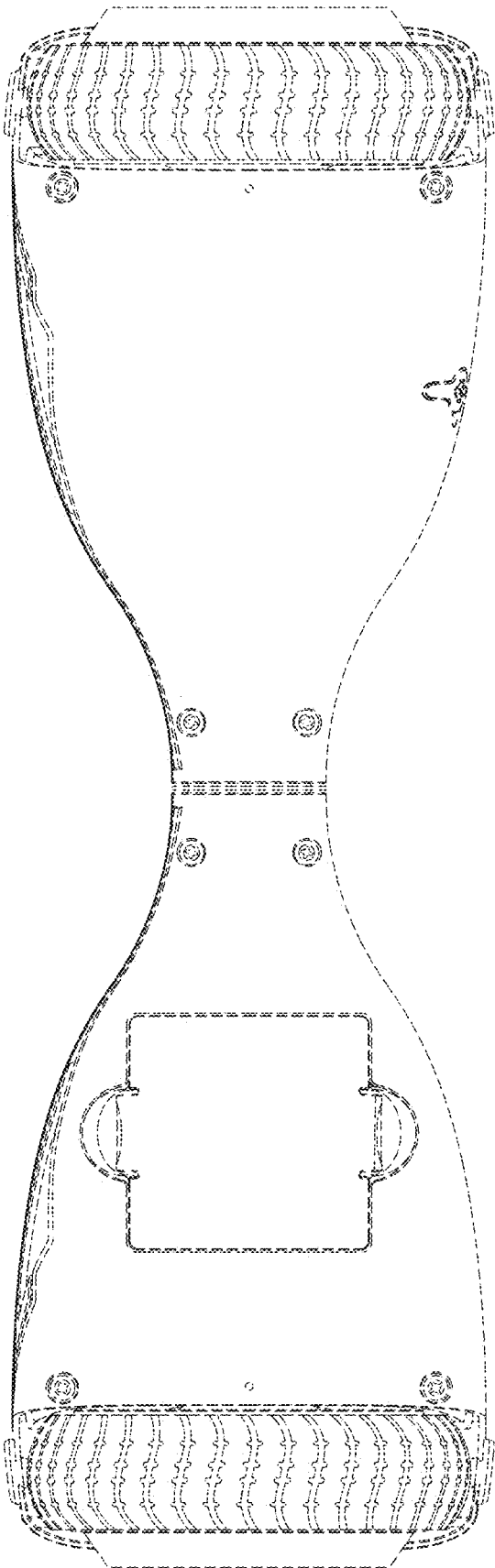

FIG. 4



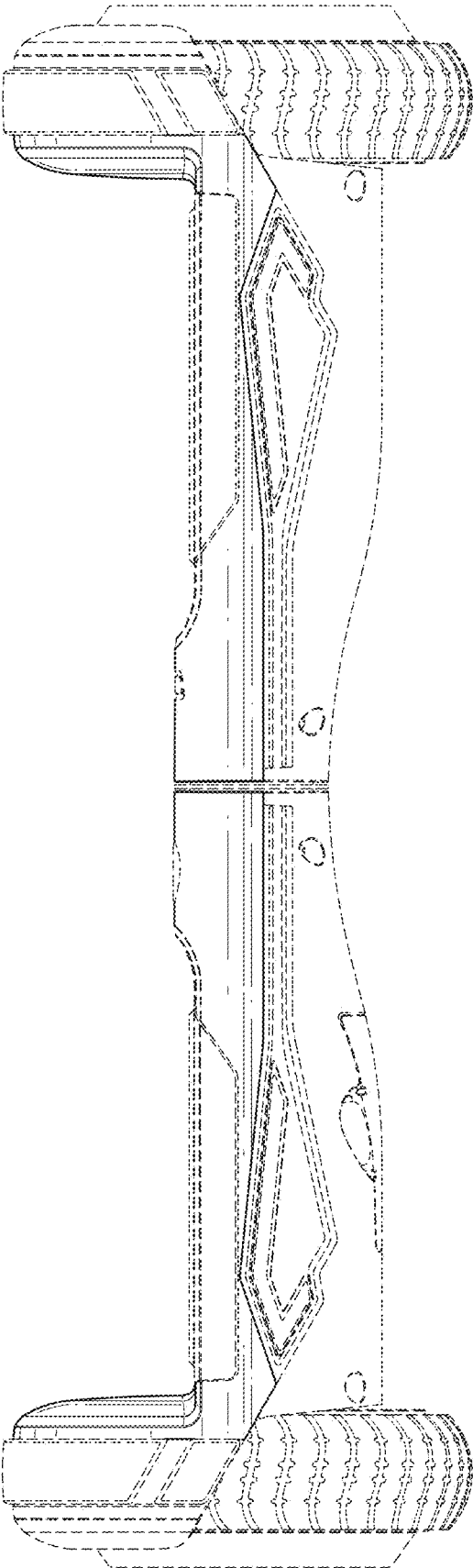

FIG. 5

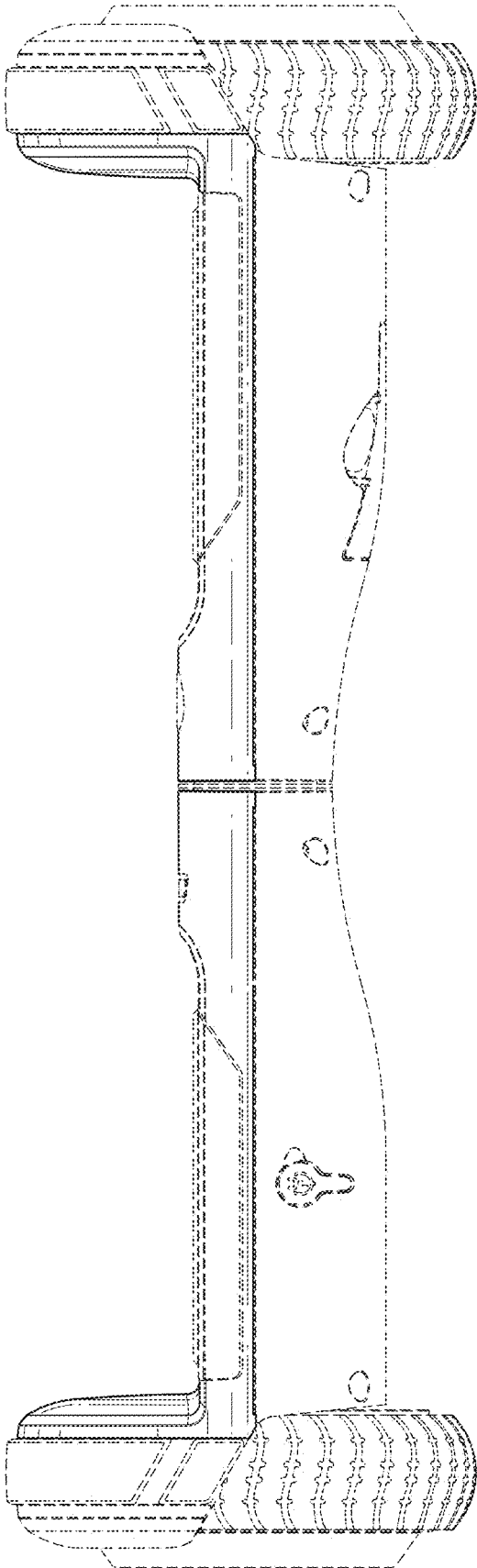

FIG. 6

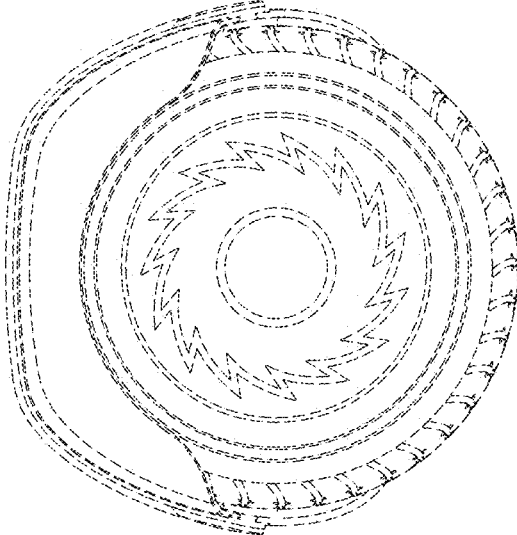

FIG. 8

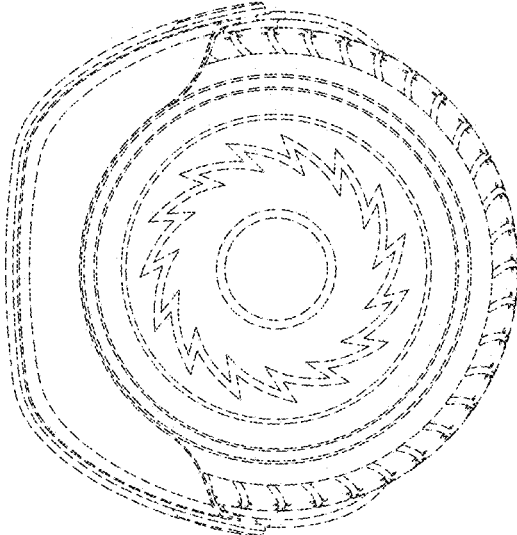

FIG. 7