

W. B. PITKIN.
 MOISTENING DEVICE FOR PRINTING PRESSES.
 APPLICATION FILED DEC. 17, 1917.

1,335,026.

Patented Mar. 30, 1920.

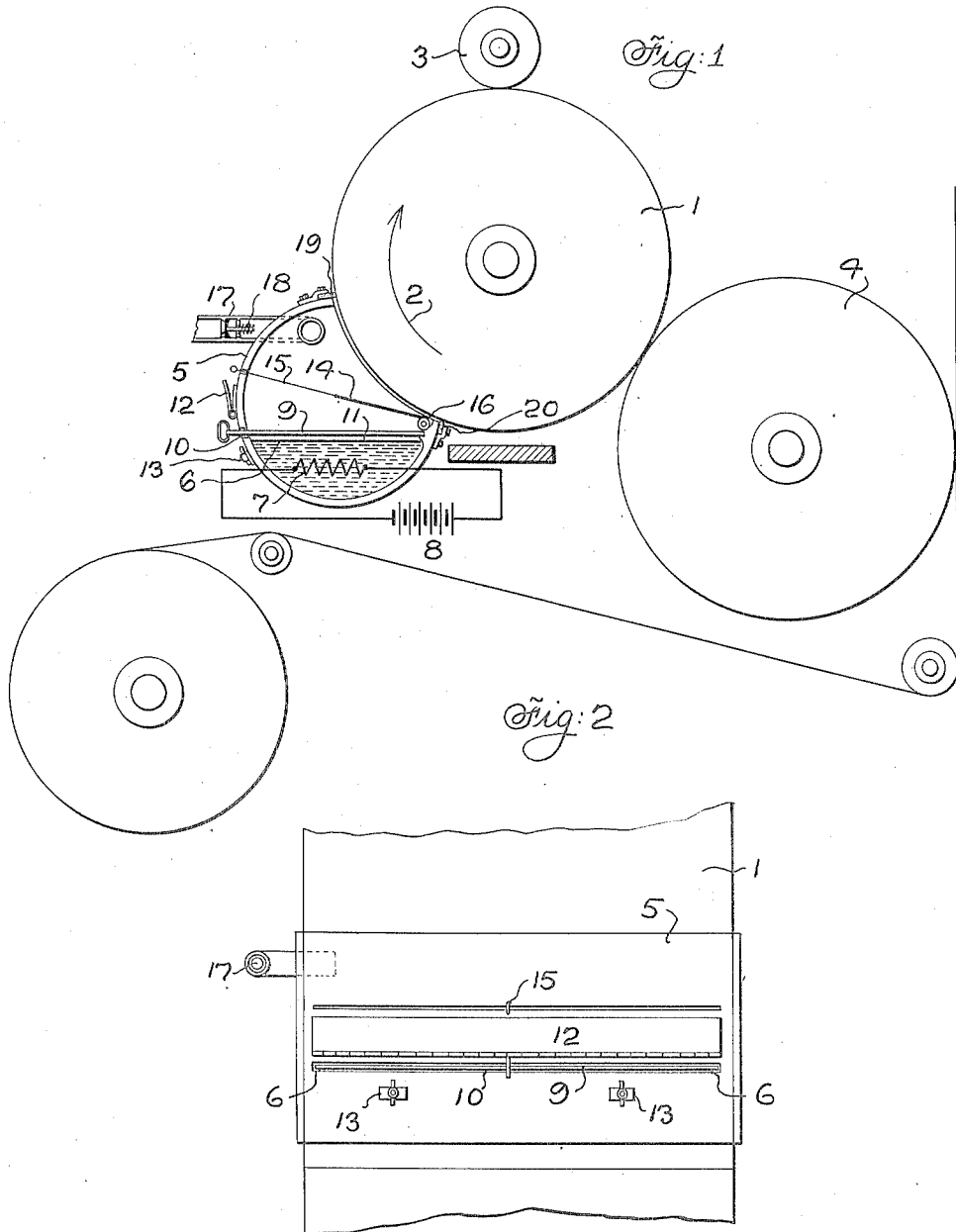

Walter B Pitkin Inventor

By his Attorney,
 Emery, Bother, James & Nalley

UNITED STATES PATENT OFFICE.

WALTER B. PITKIN, OF NEW YORK, N. Y., ASSIGNOR TO PLANOGRAPHIC EQUIPMENT COMPANY, INCORPORATED, OF NEW YORK, N. Y., A CORPORATION OF NEW YORK.

MOISTENING DEVICE FOR PRINTING-PRESSES.

1,335,026.

Specification of Letters Patent.

Patented Mar. 30, 1920.

Application filed December 17, 1917. Serial No. 207,451.

To all whom it may concern:

Be it known that I, WALTER B. PITKIN, a citizen of the United States, and a resident of the city, county, and State of New York, have invented an Improvement in Moistening Devices for Printing-Presses, of which the following is a specification.

My invention relates to means for moistening or dampening a printing surface, such, for instance, as a planographic plate, lithographic stone, or other surface, and refers more particularly to a means of accomplishing such moistening through the action of steam which is condensed upon the surface.

In general, my invention comprises means for conveniently generating such steam and applying it to the printing surface, where it is condensed, but it also includes certain auxiliary features, such as means for wholly or partially screening the printing surface from the action of steam so generated, means for removing any excess of moisture which may collect upon the plate, etc.

My invention is applicable to various kinds of printing presses, such, for instance, as the rotary offset press, in connection with which I have illustrated it in the drawings, and I therefore do not intend to confine myself to its application to any particular type of press.

In the drawings, which are more or less diagrammatic and intended to illustrate one form of my invention only, although it is capable of embodiment in many different forms, I have shown,

In Figure 1, a transverse sectional view of my improved moistening device; and

In Fig. 2, a side view thereof.

My invention is illustrated in connection with a rotary offset press, portions of the press being indicated diagrammatically.

Referring to the drawings, 1 indicates a form cylinder of a press. By form cylinder I intend to designate the cylinder upon which the printing surfaces to be moistened are carried, no matter what the character of these printing surfaces is. The form cylinder revolves in the direction of the arrow 2 and is inked by any suitable inking mechanism, indicated by the ink roller 3. The form cylinder coöperates with the offset cylinder 4.

Adjacent to the form cylinder 1 and in

close proximity thereto, so as to inclose a portion of its surface, is a housing 5, having an open side adjacent the form cylinder 1. The housing 5 is adapted to contain water or any other suitable liquid, which water may be maintained at or about the level 6, in any suitable way. The water is heated to the boiling point by means of a heating element 7, which may consist of a plurality of coils of wire of a relatively high resistance, through which a current is passed from a source of electricity 8, or if preferred, the water may be heated by a steam pipe, or any other suitable means. The steam thus formed ascends and comes directly into contact with the printing surface carried upon the form cylinder 1 as it passes in front of the opening of the housing 5, due to the rotation of the form cylinder, and deposits water of condensation thereon, due to the rapid conduction of heat away from the printing surface, by reason of the relatively large mass of the form cylinder 1.

The temperature of the heating element may be regulated thermostatically by any suitable thermostatically operated device, adapted to open the circuit of the source of heating current 8, or if some other form of heating be used, to otherwise shut off the heat. Since such devices are in common use and many of them may be applied to this specific purpose, I have not illustrated any such apparatus.

I provide means for wholly or partially screening the plate from the action of the steam, since it will be understood that if the press is stationary, the moistening device should be shut off, and if the press is operated at a relatively low speed, a smaller part of the printing surface should be exposed at one time than would be exposed if the press were operated at a relatively higher speed. Thus, if it has been determined that to properly moisten a given portion of the printing surface, it should be exposed to the action of the steam for a given time, the area of the opening of the housing should be restricted if the peripheral speed of the form cylinder is decreased.

I have therefore shown a means for completely shutting off the printing surface from the action of the steam, which comprises a shutter 9, preferably of metal, which extends through a slot 10 in the hous-

ing, extending across substantially its entire width and runs in grooves or upon rails 11 in the ends thereof. This shutter is entirely removed when the press is started up.
 5 The slot 10 may be closed by means of a shutter 12, which may be held in closed position by means of the latch 13.

For partially screening the printing surface, I have shown a curtain 14 of flexible material, such as rubber or duck, which is operated by means of a cable 15, extending through the housing 5. The curtain is rolled upon a spring actuated roller 16 attached to the inner wall of the housing 5.
 15 By moving the curtain 14, a greater or less distance across the opening in the housing 5, a greater or less area of printing surface may be exposed to the steam as required.

The steam within the housing is preferably kept at about atmospheric pressure, in order to prevent leakage between the housing and the form cylinder, and I have therefore provided a relief valve 17, the tension of the spring 18 of which is adjusted to
 25 approximately a pressure of one pound.

Attached to the upper side of the housing 5 and in close proximity to the printing surface upon the form cylinder 1 is a wiper 19, preferably of soft rubber or some similar material, to prevent abrasion of the printing surface by reason of accidental contact. The wiper is arranged in as close proximity as possible to the printing surface, so as to prevent the escape of steam
 30 and to break up any globules of water which may be formed upon the printing surface, and to distribute the water evenly over the printing surface. A similar wiper 20 is provided at the lower end of the housing, so
 40 as to prevent the escape of steam and to remove any foreign matter which may collect upon the printing surface.

While I have only illustrated and described one form of my invention, I do not
 45 intend to confine myself thereto, as it is evident that many changes may be made without departing from its spirit.

I have referred to the use of steam as a moistening agent and in general that will
 50 be the preferred arrangement, but water vapor or vapor from other liquids under some circumstances may be desirable, and these I consider equivalents for the purposes of this invention. For instance, on
 55 damp days in hot weather the condensation from a body of water in the tank would ordinarily be sufficient and in that case the heating apparatus might not be used. Such a use of the apparatus, however, I consider
 60 within my invention.

What I claim is:

1. In a device of the kind described, a printing surface, a housing having an opening adjacent the printing surface, and

means for generating steam within the housing for contact with the printing surface. 65

2. In a device of the kind described, a printing surface and means for exposing the printing surface to steam, comprising a housing having an opening adjacent the
 70 printing surface and adapted to contain water, and a heating element immersed therein.

3. In a device of the kind described, a printing surface, means for exposing the printing surface to steam, comprising a
 75 housing in close proximity to the plate and adapted to contain a fluid, means for boiling the fluid and means for varying the area affected at one time by the steam generated. 80

4. In a device of the kind described, a printing surface, a housing having an open side adjacent the printing surface and adapted to contain a fluid, means for boiling
 85 the fluid, and means for partly closing the open side of the housing.

5. In a device of the kind described, a printing surface, a housing having an open side adjacent the printing surface and adapted to contain water; means for heating
 90 the water in said housing to generate steam for contact with said printing surface, and means for partly closing the open side of the housing.

6. In a device of the kind described, a
 95 printing surface, a housing adapted to contain water adjacent the printing surface, a heating element immersed therein to boil the water, and means for wholly or partially screening the printing surface from
 100 the steam thus formed.

7. In a device of the kind described, a printing surface, a housing adapted to contain water and having an open side adjacent the printing surface, means for heating
 105 said water to the boiling point, means for wholly or partially screening the printing surface from the vapor thus formed and a wiper in close proximity to the printing surface, for removing the surplus water
 110 of condensation.

8. In a device of the kind described, a printing surface, a housing having an open side adjacent the printing surface and adapted to contain water, a heating element
 115 immersed therein and adapted to bring the water to the boiling point, means for wholly or partially screening the printing surface from the steam so generated, a wiper located at the edge of the opening of the
 120 housing and adapted to remove surplus water of condensation, and an automatic steam blow-off valve communicating with said housing.

In testimony whereof, I have signed my
 name to this specification this eighth day of
 December, 1917. 125

WALTER B. PITKIN.