

No. 729,142.

PATENTED MAY 26, 1903.

R. DEMPSTER.
CARBURETER.

APPLICATION FILED JULY 7, 1902.

NO MODEL.

2 SHEETS—SHEET 1.

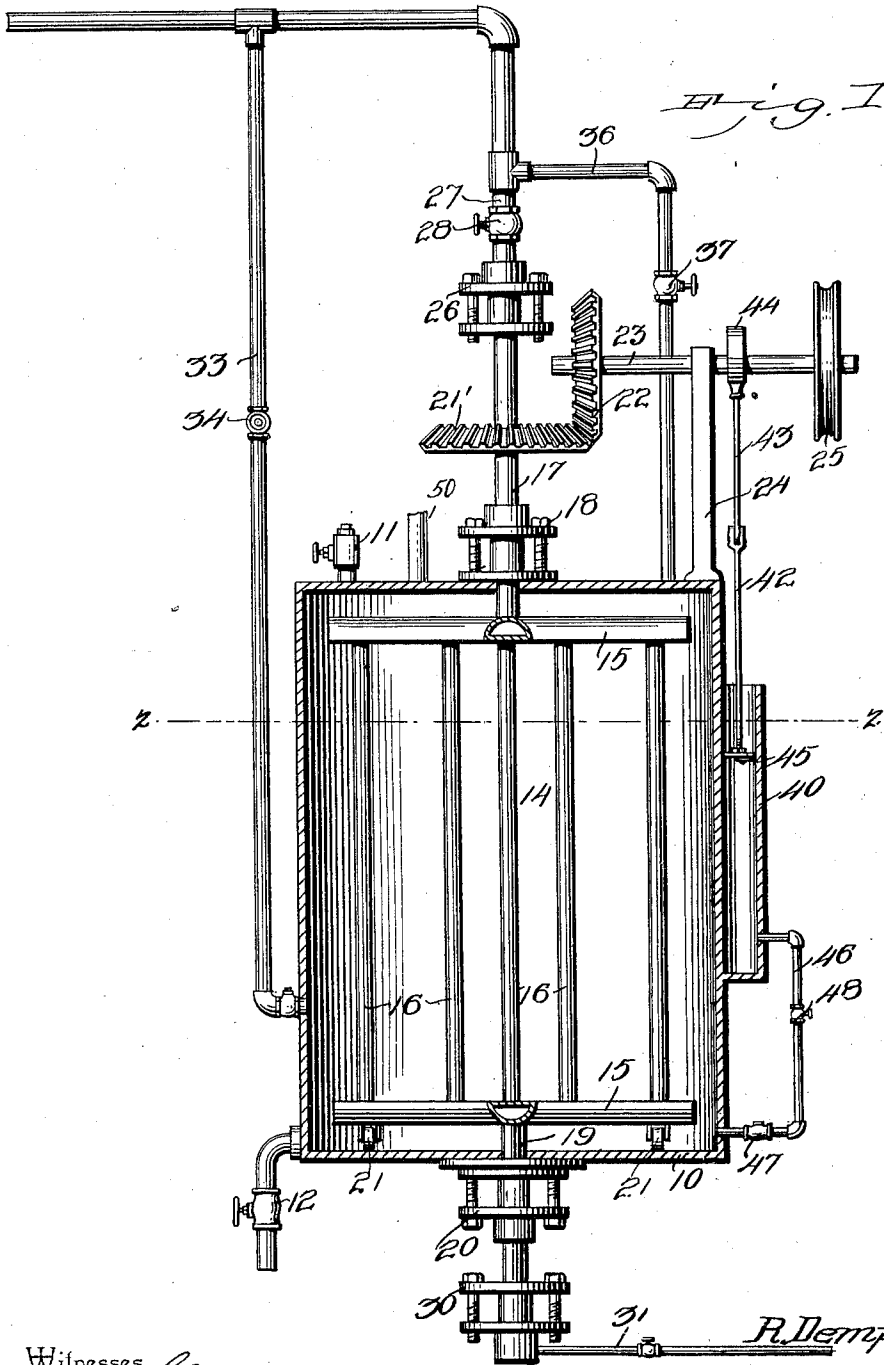

Witnesses
E. J. Stewart
J. W. E. Parker

by *R. Dempster,*
 Inventor.
C. A. Snow & Co.
 Attorneys

No. 729,142.

PATENTED MAY 26, 1903.

R. DEMPSTER.
CARBURETER.

APPLICATION FILED JULY 7, 1902.

NO MODEL.

2 SHEETS—SHEET 2.

Fig. 3.

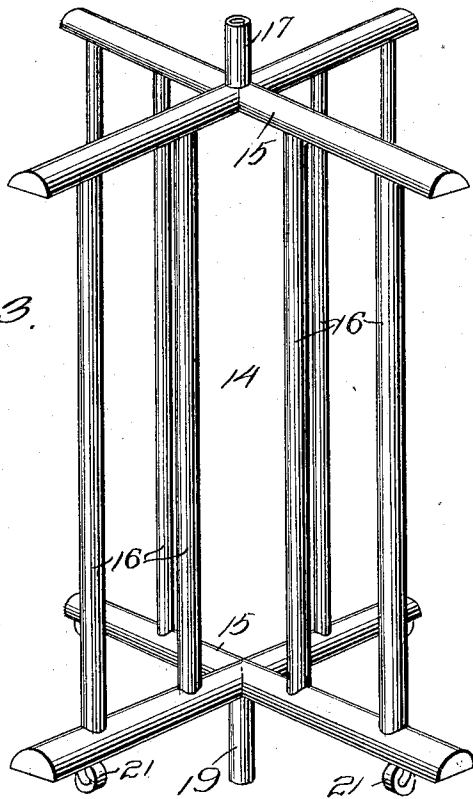
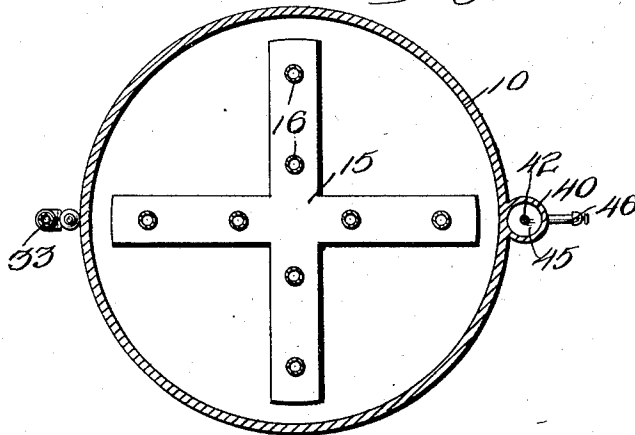

Fig. 4.



Witnesses
E. H. Lewis
J. C. Parker

R. Dempster, Inventor.
by *Chas. H. Snow*
Attorneys

UNITED STATES PATENT OFFICE.

ROBERT DEMPSTER, OF MARIETTA, OHIO.

CARBURETER.

SPECIFICATION forming part of Letters Patent No. 729,142, dated May 26, 1903.

Application filed July 7, 1902. Serial No. 114,636. (No model.)

To all whom it may concern:

Be it known that I, ROBERT DEMPSTER, a citizen of the United States, residing at Marietta, in the county of Washington and State of Ohio, have invented a new and useful Improvement in Carbureters, of which the following is a specification.

This invention relates to certain improvements in apparatus for the formation of hydrocarbon vapors or gas from a mixture of liquid hydrocarbon, air, and steam.

The principal object of the invention is to provide a novel form of apparatus by means of which a vapor or gas having any desired percentage of hydrocarbon may be manufactured at small cost and used directly, either with or without the admixture of air, as an explosive compound for gas-engines, or the vapor may be conducted to and through a suitable retort for the formation of a fixed gas.

A further object of the invention is to render the device applicable for the formation of vapor from heavy or crude oils having sulfur, tar, and other heavy impurities by providing an improved form of agitator which will hold the impurities in suspension and prevent their settling to the bottom of the generator until such time as it is desired to withdraw the heavier carbonaceous matter and renew the supply of oil in the tank.

A still further object of the invention is to provide means for heating and agitating the oil and at the same time forcing through such oil any desired quantity of steam and air to combine with the hydrocarbon and form a gas, while the percentage of hydrocarbon contained in the gas or vapor may be regulated by the admixture of any desired quantity of steam directly in the generating-tank or by the admixture of air or steam with the vapor before the latter is utilized.

With these and other objects in view the invention consists in the novel construction and combination of parts hereinafter described, illustrated in the drawings, and particularly pointed out in the appended claims.

In the drawings, Figure 1 is a longitudinal sectional elevation of a gas-generating apparatus constructed in accordance with my invention. Fig. 2 is a sectional plan view of the same on the line 2 2 of Fig. 1. Fig. 3 is

a detail perspective view of the oil-agitating device.

Similar numerals of reference are employed to indicate corresponding parts throughout the several figures of the drawings.

In the drawings, 10 indicates a closed tank, in which is placed the quantity of hydrocarbon oil from which the gas is to be manufactured. The oil may be of any desired quality; but for the sake of economy I prefer to employ crude or partially-refined petroleum. The oil is inserted in the tank through a suitable filling-pipe 11, which is closed after the desired quantity has been admitted, while the heavy hydrocarbons are withdrawn from time to time through an outlet-pipe 12. In the tank is placed an agitating and heating device 14 of the construction more clearly shown in Fig. 3 and comprising upper and lower arms 15, radiating from the common center and connected by vertical pipes 16. All of the arms are hollow and are approximately semicircular cross-sections, the flat sides being tapped for the reception of the threaded ends of the tubes 16. To the upper set of arms is connected a steam-pipe 17, passing out through a stuffing-box 18 at the top of the tank, and to the lower arm is connected a pipe 19, extending out through a stuffing-box 20 at the bottom of the tank. The upper and lower pipes form an axis for the rotation of the agitator, the weight of the latter being supported by rollers 21, carried by the lower arms and running on the bottom of the tank. Both the upper and lower pipes rotate, the upper pipe carrying a bevel-gear 21', intermeshing with a similar gear 22 on a horizontal shaft 23. The shaft 23 is held in bearings in a bracket 24 and is provided with a belt-wheel 25, through which motion is transmitted from any suitable source of power.

At the upper end of the pipe 17 is a stuffing-box 26, into which extends the lower end of a steam-pipe 27, the latter being stationary and provided with a valve 28 to govern the supply of steam to the agitator 14. The lower pipe 19 is provided with a stuffing-box 30, into which extends a valved pipe 31 to permit the circulation of the steam and to withdraw when necessary the water of condensation.

The steam-pipe 27 leads from a suitable

steam-generating apparatus, which may be in the form of an ordinary steam-boiler or may be in the form of an auxiliary tank or retort in a gas-generating apparatus where the device forming the subject of my present invention is designed to furnish a hydrocarbon vapor to a retort or other device for the manufacture of a fixed gas. To this steam-pipe is connected a branch pipe 33, leading into the oil-reservoir 10 at a point considerably below the liquid-level in the tank. This pipe is provided with a valve 34 for controlling the quantity of steam admitted, and the steam is preferably superheated, so that it may more readily combine with the carbon of the oil. Steam is also admitted to the tank at a point above the liquid-level by a pipe 36, having a controlling-valve 37, the steam admitted at this point being for the purpose of mingling with the oil-vapor above the liquid-level and reducing the gas. In some cases this additional steam-supply need not be employed, or the steam for reducing purposes may be mingled with the vapor at the point of consumption, and it may be mingled with the oil either as steam or as steam superheated to a degree sufficient to disassociate its constituent elements.

At one side of the generating-tank is a pump-cylinder 40, in which is a piston connected by a rod 42 and pitman 43 to an eccentric or crank 44 upon the shaft 23. Air is admitted to the top of the cylinder, and the piston is provided with an ordinary form of flat valve 45 to admit air between the piston and the lower end of the cylinder, the valve closing on the downstroke of the piston, while the air in the lower portion of the cylinder is forced through a pipe 46 into the bottom of the oil-reservoir, the air forcing its way up through the boiling oil and becoming saturated with the hydrocarbon. The pipe 46 is provided with a check-valve 47 to prevent the flow of oil into the pipe on the upstroke of the piston or plunger and is further provided with a controlling-valve 48 for governing the quantity of air admitted to the reservoir.

In the operation of the device the tank is filled to about two-thirds of its capacity with oil, and steam is admitted to the agitating device, the latter being turned at any desired rate of speed and heating the oil to the boiling-point or slightly above the boiling-point, so that vapor will form above the oil-level. The agitating device is rotated at a speed sufficient to prevent the heavier carbons and impurities from settling to the bottom of the tank and at the same time by the constant churning of the oil permitting the free escape of the vapor to the surface of the oil. Steam is then admitted through the pipe 33 and air through the pipe 46, the air and steam being forced into and through the liquid hydrocarbon and during its passage to the surface of the oil becoming thoroughly saturated with hydrocarbon and there mingling with the va-

por formed by the heating of the oil. In order to dilute the vapor or gas, steam is then admitted in any desired quantity through the pipe 36, and the vapor passes off through an outlet-pipe 50 to the point of consumption or to a fixing-chamber, where it is heated to an extent sufficient to form a fixed gas.

The apparatus is found of exceptional value for the production of an explosive compound for gas-engines in locations where ordinary gas cannot be obtained; but it may also be employed for the formation of vapor or gas for heating, lighting, or other purposes.

While the construction herein described, and illustrated in the accompanying drawings, is the preferred form of the device, it is obvious that various changes in form, proportions, size, and minor details of construction may be made without departing from the spirit or sacrificing any of the advantages of my invention.

Having thus described my invention, what I claim is—

1. In a device of the class specified, an oil-containing tank, a combined agitator and heater arranged within the tank and comprising upper and lower sets of hollow arms and tubes connecting said arms, steam supply and discharge pipes connected to said agitator and heater, means for revolving the same, and means for introducing air into said tank at a point below the level of the oil.

2. In a device of the class specified, an oil-containing tank, a combined agitator and heater arranged within said tank, steam supply and discharge pipes extending through the top and bottom of the tank, means for revolving said pipes together with the agitator and heater, and air and steam inlets leading into the tank at a point below the level of oil.

3. In a device of the class specified, an oil-containing tank having upper and lower stuffing-boxes, steam-tubes extending through the stuffing-boxes, radially-disposed hollow arms arranged in upper and lower sets and connected to the steam-tubes, steam-pipes connecting the upper and lower sets of arms, supporting-rollers carried by the lower set of arms and resting on the bottom of the tank, the whole comprising a combined agitating and heating device, mechanism for revolving said agitating and heating device, and means for introducing air into the tank at a point below the level of oil.

4. In a device of the class specified, an oil-containing tank having upper and lower stuffing-boxes, steam-tubes extending through the stuffing-boxes, an agitator and heater connected to said tubes, means for revolving the same, air and steam inlets leading into the tank at points below the oil-level, a steam-inlet above the oil-level, and a gas-outlet pipe leading from said tank.

5. In a device of the class specified, an oil-containing tank, a combined agitating and heating device arranged therein, steam-pipes

leading to and from the agitating and heating device, auxiliary steam-pipes connected respectively to the tank at points above and below the liquid-level, a revoluble shaft having
5 an operative connection with the agitating and heating device, an air-pump having an outlet-pipe in communication with the lower portion of the tank, a piston forming a part of said air-pump, and means for operatively con-

necting said piston to the shaft, substantially as specified.

In testimony that I claim the foregoing as my own I have hereto affixed my signature in the presence of two witnesses.

ROBERT DEMPSTER.

Witnesses:

HENRY ROLSER,
JNO. STURGESS.