



(12) **DEMANDE DE BREVET CANADIEN  
CANADIAN PATENT APPLICATION**

(13) **A1**

(86) Date de dépôt PCT/PCT Filing Date: 2022/09/26  
 (87) Date publication PCT/PCT Publication Date: 2023/04/20  
 (85) Entrée phase nationale/National Entry: 2024/04/09  
 (86) N° demande PCT/PCT Application No.: US 2022/044719  
 (87) N° publication PCT/PCT Publication No.: 2023/064089  
 (30) Priorité/Priority: 2021/10/15 (US63/256,264)

(51) Cl.Int./Int.Cl. *C01B 3/24* (2006.01),  
*C01B 3/02* (2006.01), *C01B 3/34* (2006.01),  
*C01B 3/22* (2006.01)  
 (71) Demandeur/Applicant:  
DG FUELS, LLC, US  
 (72) Inventeurs/Inventors:  
DARCY, MICHAEL C., US;  
HORNER, MICHAEL W., US;  
FREERKS, ROBERT L., US;  
FROST, LYMAN JOSEPH, US;  
SALINAS, JUAN FRANCISCO PEARCY, US;  
MONTOTO, DANIEL BENJAMIN, US  
 (74) Agent: ROBIC AGENCE PI S.E.C./ROBIC IP AGENCY  
LP

(54) Titre : PROCÉDES ET SYSTÈMES DE PRODUCTION DE COMBUSTIBLES HYDROCARBONÉS AYANT UNE EFFICACITÉ DE CONVERSION DE CARBONE ÉLEVÉE  
 (54) Title: PROCESSES AND SYSTEMS FOR PRODUCING HYDROCARBON FUELS HAVING HIGH CARBON CONVERSION EFFICIENCY

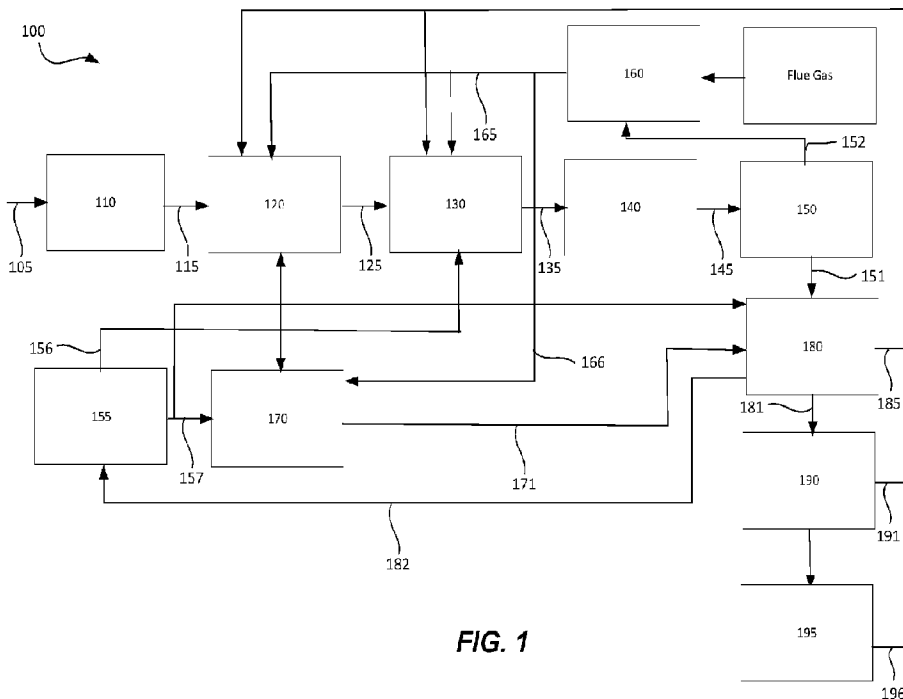

FIG. 1

(57) **Abrégé/Abstract:**

The present disclosure relates to a processes and systems for producing fuels from biomass with high carbon conversion efficiency. The processes and systems described herein provide a highly efficient process for producing hydrocarbons from biomass with very low Green House Gas (GHG) emissions using a specific combination of components, process flows, and recycle streams. The processes and systems described herein provide a carbon conversion efficiency greater than 95 % with little to no GHG in the flue gas due to the novel arrangement of components and utilizes renewable energy to provide energy to some components. The system reuses water and carbon dioxide produced in the process flows and recycles naphtha and tail gas streams to other units in the system for additional conversion to syngas to produce hydrocarbon- based fuels.

**Date Submitted:** 2024/04/09

**CA App. No.:** 3234421

**Abstract:**

The present disclosure relates to a processes and systems for producing fuels from biomass with high carbon conversion efficiency. The processes and systems described herein provide a highly efficient process for producing hydrocarbons from biomass with very low Green House Gas (GHG) emissions using a specific combination of components, process flows, and recycle streams. The processes and systems described herein provide a carbon conversion efficiency greater than 95 % with little to no GHG in the flue gas due to the novel arrangement of components and utilizes renewable energy to provide energy to some components. The system reuses water and carbon dioxide produced in the process flows and recycles naphtha and tail gas streams to other units in the system for additional conversion to syngas to produce hydrocarbon- based fuels.

**PROCESSES AND SYSTEMS FOR PRODUCING HYDROCARBON FUELS  
HAVING HIGH CARBON CONVERSION EFFICIENCY**

**CROSS-REFERENCE TO RELATED APPLICATION**

**[0001]** This application claims the benefit of and priority to U.S. Provisional Application No. 63/256,264, filed October 15, 2021, the disclosure of which is hereby incorporated by reference in its entirety.

**FIELD OF THE INVENTION**

**[0002]** The present disclosure relates to processes and systems for processing renewable feedstocks to produce hydrocarbon-based fuels. More specifically, the present disclosure provides a highly efficient process for producing hydrocarbon-based fuels from biomass with very low Green House Gas (GHG) emissions using a specific combination of components and process flows.

**BACKGROUND**

**[0003]** In an effort to reduce dependence on petroleum energy sources and reduce greenhouse gas emissions, several studies have been done to explore alternative, non-petroleum based processes to produce liquid fuels. These alternative studies include the production of synthetic liquid hydrocarbons from biomass, coal, and natural gas using a synthesis gas (“syngas”) intermediate. These energy processes have emerged as viable options due to their capabilities to produce liquid fuels via domestically available sources of carbon based energy. A common feature of these synthetic processes, however, is the large amount of CO<sub>2</sub> emitted from the system.

**[0004]** Conventional processes for converting natural gas feeds into syngas typically include autothermal or steam methane reforming. The conversion of natural gas or biomass feeds into liquid fuels is referred to as gas to liquids (GTL) and biomass to liquids (BTL), respectively. The generic process includes converting the feed materials, e.g., biomass and/or natural gas, into a mixture of synthesis gas (“syngas,” comprising H<sub>2</sub> and CO) for conversion

into liquid hydrocarbons via the Fischer Tropsch process. The liquid hydrocarbons are subsequently upgraded, e.g., through distillation, hydrocracking, and/or isomerization, to form the final products (e.g., diesel or synthetic petroleum kerosene (“SPK”). In both feed conversion steps into synthesis gas, intermediate processing steps remove impurities and excess CO<sub>2</sub> which can be detrimental to the FT catalytic process for production of the final fuel products. Of particular concern are sulfur containing compounds, such as H<sub>2</sub>S, COS, SO<sub>2</sub>, or mercaptans, as sulfur irreversibly deactivates FT catalysts. Other non-desired contaminants such as H<sub>2</sub>O and CO<sub>2</sub> can also affect the FT catalyst performance via dilution of the primary synthesis reactants (e.g., H<sub>2</sub> and CO) and/or temporary deactivation due to oxidation of active metals. H<sub>2</sub>O is one of the products of the FT reaction and thus the presence of water affects the chemical equilibrium for the formation of desired hydrocarbon product. In order to optimize carbon efficiency (ratio of product carbon to feed carbon) several recycle loops are added to the process configuration.

**[0005]** A primary concern during hydrocarbon synthesis centers around maximizing the utilization of the input carbon from the feedstock, i.e., converting as much feed carbon into product carbon, while using an acceptable amount of energy (from any source) with acceptable environmental emissions, predominantly CO<sub>2</sub> emissions and produced water requiring treatment for trace contaminants. Currently, the collection and sequestration of CO<sub>2</sub> is based on the trade-off between the added energy for capture and compression of CO<sub>2</sub> for it to be sequestered, and the reduction of CO<sub>2</sub> emissions. However, these additional processing steps for reducing CO<sub>2</sub> emissions require additional energy and resources, which effectively increases energy consumption, and adds inefficiency to the hydrocarbon synthesis process as additional CO<sub>2</sub> gets captured and sequestered. Since the aforementioned capture, pressurization, and sequestration utilize energy; those steps can also increase greenhouse gas emissions thereby offsetting a portion of the benefit gathered from sequestration.

**[0006]** In view of the foregoing, the need exists for optimizing carbon conversion and reducing and/or removing CO<sub>2</sub> emissions from processes for producing hydrocarbon-based fuels.

## SUMMARY OF THE INVENTION

**[0007]** Covered embodiments of the present disclosure are defined by the claims, not this summary. This summary is a high-level overview of various aspects of the invention and introduces some of the concepts that are further described in the Detailed Description section below. This summary is not intended to identify key or essential features of the claimed subject matter, nor is it intended to be used in isolation to determine the scope of the claimed subject matter. The subject matter should be understood by reference to appropriate portions of the entire specification, any or all drawings, and each claim.

**[0008]** In some embodiments, the present disclosure provides a system for producing a hydrocarbon-based fuel. The system includes a biomass feedstock processing unit configured to remove waste from a feedstock to produce a processed feedstock; a gasification unit in communication with the biomass feedstock processing unit, wherein the gasification unit is configured to convert the processed feedstock into syngas comprising carbon dioxide, carbon monoxide, and hydrogen; a reactor downstream from the gasification unit, wherein the reactor is operated at suitable conditions to promote conversion of portions of the syngas to produce a proper ratio of hydrogen to CO; a scrubber in communication with the reformer, wherein the scrubber removes carbon dioxide from the syngas to produce a purified syngas having a hydrogen to carbon monoxide ratio of at least 1.5:1; a Fischer Tropsch reactor for receiving the purified syngas, wherein the Fischer Tropsch reactor converts the purified syngas into Fischer-Tropsch liquids, produced water, and tail gas; a water purification system to purify the produced water for electrolysis; and an electrolysis unit configured to receive the purified produced water from the Fischer Tropsch reactor, wherein the electrolysis unit converts the purified produced water into an oxygen stream and a hydrogen stream. A portion of the oxygen stream produced from the electrolysis unit is recycled to the gasification unit, a methane reformer, or combinations thereof. The system achieves at least 90 % carbon conversion of the feedstock. In some embodiments, the system includes a reverse water-gas shift reactor. A portion of the carbon dioxide removed from the syngas in the scrubber is recycled to the reverse water-gas-shift reactor. In some embodiments, a portion of the hydrogen stream produced by the electrolysis unit is provided to the reverse water-gas shift reactor. The reverse water-gas shift reactor is configured to produce carbon monoxide that is

supplied to the Fischer Tropsch reactor. In some embodiments, the syngas stream and the hydrogen stream are pressurized prior to being supplied to the Fischer Tropsch reactor. In some embodiments, the tail gas from the Fischer Tropsch reactor is recycled to the reformer. In some embodiments, the system includes a hydrocracker unit, a fractionation unit, or combinations configured to upgrade the Fischer-Tropsch liquids into various fuels, wherein a byproduct of the hydrocracker unit comprises tail gas, wherein a byproduct of the fractionation unit comprises naphtha. In some embodiments, the tail gas, naphtha, or both, are recycled to the reformer. In some embodiments, the system includes a flue gas scrubber configured to scrub any flue gas generated by the system. In some embodiments, the system includes a carbon dioxide treatment and compression system, wherein carbon dioxide produced from the scrubber and the flue gas scrubber is processed in the carbon dioxide treatment and compression system to produce a purified carbon dioxide stream, wherein the purified carbon dioxide stream is recycled to the reformer, the reverse water-gas shift reactor, a CO<sub>2</sub> electrolysis unit, or combinations thereof. In some embodiments, the feedstock comprises one or more of railroad ties, greasewood, corn stover, orchard prunings, forest thinnings, slash, switch grass, wood chips, lignin, and cellulosic material. In some embodiments, the feedstock comprises woody biomass. In some embodiments, the system includes a pre-reformer and an autothermal reforming unit or steam methane reformer configured to convert a natural gas feedstock into syngas. In some embodiments, the system includes a CO<sub>2</sub> electrolysis unit configured to convert CO<sub>2</sub> recovered from the system into carbon monoxide and O<sub>2</sub>. In some embodiments, the O<sub>2</sub> from the CO<sub>2</sub> electrolysis may be sent to the gasifier, the reactor (e.g., a reformer), or other unit in the system using O<sub>2</sub> in its process. The carbon monoxide can be fed to the Fischer Tropsch reactor.

**[0009]** In some embodiments, the present disclosure provides a process for producing a hydrocarbon-based fuels. The process includes gasifying a biomass feedstock to produce a first crude syngas stream comprising carbon dioxide, hydrogen, and carbon monoxide; reforming the first crude syngas stream to produce a hydrogen-enriched syngas stream; separating carbon dioxide from the hydrogen-enriched syngas stream in a separation unit to produce a carbon dioxide stream and a purified syngas stream having a hydrogen to carbon monoxide ratio of at least 1.5:1; enriching the purified syngas with additional hydrogen

obtained via water electrolysis; reacting the purified syngas stream and hydrogen enriched syngas stream in a Fischer Tropsch reactor to produce Fischer-Tropsch liquids, water, and tail gas; recycling a portion of the produced water from the Fischer Tropsch reactor to a water purification step and subsequently to an electrolysis unit; and electrolyzing the purified water in the electrolysis unit to produce an oxygen stream and a hydrogen stream. In some embodiments, the process includes purifying the carbon dioxide stream generated from the separation unit to produce a purified carbon dioxide stream. In some embodiments, the process includes recycling the purified carbon dioxide stream to a “dry” reforming unit, the reverse water-gas-shift reactor, or combinations thereof. In some embodiments, the process includes recycling a portion of the oxygen stream and a portion of the hydrogen stream to the gasification step, the dry reforming step, the Fischer Tropsch reactor, or combinations thereof. In some embodiments, the process includes recycling a portion of the hydrogen stream and a portion of the purified carbon dioxide stream to a reverse water-gas-shift reactor to produce carbon monoxide to augment the syngas in the Fischer Tropsch reactor, increase the carbon utilization and to produce additional Fischer-Tropsch liquids. In some embodiments, the process includes feeding the carbon monoxide produced from the reverse water-gas-shift reactor to the Fischer Tropsch reactor to augment syngas into the Fischer Tropsch reactor and produce additional Fischer-Tropsch liquids. In some embodiments, the process includes processing natural gas in a reforming unit to produce a second syngas stream that is supplied to the Fischer Tropsch reactor. In some embodiments, the electrolysis unit is powered by solar energy, wind energy, hydroelectric energy, off-peak grid power, nuclear power, or tidal energy. In some embodiments, the biomass feedstock comprises one or more of railroad ties, greasewood, corn stover, orchard prunings, forest thinnings, slash, switch grass, wood chips, lignin, and cellulosic material. In some embodiments, the process includes treating the water produced from the Fischer Tropsch reactor to produce a boiler-quality feed water, wherein the boiler-quality feed water is electrolyzed in the electrolysis unit.

**[0010]** Further aspects, objects, and advantages will become apparent upon consideration of the detailed description and figures that follow.

## BRIEF DESCRIPTION OF THE DRAWINGS

**[0011]** FIG. 1 shows a schematic diagram of a system for producing hydrocarbon fuels according to some embodiments of the present disclosure.

**[0012]** FIG. 2 shows a schematic diagram of a hydrocarbon synthesis process integrated with a CO<sub>2</sub> electrolysis unit according to some embodiments of the present disclosure.

## DETAILED DESCRIPTION

### *Introduction*

**[0013]** This present disclosure relates to processes and systems for producing fuels (e.g., liquid jet and/or diesel fuel) from biomass (e.g., forestry waste, railroad ties, greasewood, algae, agricultural wastes, municipal waste, etc.) and renewable hydrogen feedstocks. In some embodiments, the biomass comprises one or more of railroad ties, greasewood, corn stover, orchard prunings, forest thinnings, slash, switch grass, wood chips, lignin, and/or a cellulosic material. For example, forest waste and residues can be used for fuel production, which are typically treated as waste feedstocks that have smallest carbon footprint. Specifically, the processes and systems described herein provide a highly efficient process with high carbon utilization for producing hydrocarbons from biomass and renewable hydrogen and/or natural gas with very low Green House Gas (GHG) emissions using a specific combination of components and process flows described herein. In some embodiments, the processes and systems described herein provide a carbon conversion efficiency greater than 95 % with little to no GHG in the flue gas due to the addition of renewable hydrogen and also to the novel arrangement of components and process flows. For example, the system beneficially reuses water and carbon dioxide produced in the process flows and recycles naphtha and tail gas streams to other units in the system (e.g., the partial oxidation reformer and/or biomass gasifier) for additional conversion to syngas to produce hydrocarbon-based fuels.

**[0014]** Conventional processes for producing syngas (e.g., H<sub>2</sub> and CO) for conversion into liquid hydrocarbons are inherently inefficient as they involve energy intensive CO<sub>2</sub> and water (e.g., wastewater) removal processes. In fact, these processes require additional energy and resources to convert or remove CO<sub>2</sub>, thus adding inefficiencies and GHG emissions to the process. These conventional processes do not effectively convert feedstock into hydrocarbon-



based fuels, because significant amounts of energy are needed to convert or remove CO<sub>2</sub> and to recycle water produced during the hydrocarbon synthesis process, which results in high amounts of additional emissions.

**[0015]** As described herein, the processes and systems described herein achieve an unexpectedly high carbon conversion efficiency with very little GHG due to the novel arrangement of components and process flows and, optionally, the addition of renewable hydrogen. In some embodiments, the processes and systems described provide a gasification process that convert feedstock into synthesis gas (“syngas”) comprising carbon monoxide, carbon dioxide, and hydrogen, and the syngas is converted into hydrocarbon fuels using the Fisher-Tropsch process. The process may include processing a biomass in a gasification unit to form a first crude syngas stream, processing the syngas stream in a reactor (e.g., a reformer, water-gas-shift reactor, or a reverse water-gas-shift reactor) to produce a second syngas stream comprising hydrogen, carbon monoxide, and carbon dioxide, separating carbon dioxide from either or both the first and second crude syngas streams in a separation unit to form a carbon dioxide stream and a syngas stream that is substantially free of CO<sub>2</sub>, purifying the carbon dioxide stream, and recycling the purified carbon dioxide to a dry reformer. The process may include reacting the syngas stream in a Fischer Tropsch reactor to produce the hydrocarbon product and water. In some embodiments, the process includes purifying the produced water and electrolyzing purified water and/or carbon dioxide in an electrolysis unit to produce hydrogen and/or carbon monoxide.

**[0016]** In some embodiments, the process may include converting carbon dioxide by feeding hydrogen from the electrolysis unit and the CO<sub>2</sub> in a reverse water-gas-shift reactor to form syngas. In some embodiments, the hydrocarbon-based fuel produced in the Fischer Tropsch reactor is upgraded in a hydrocracking unit and/or fractionation unit. The Fischer Tropsch reactor may produce synthetic paraffinic kerosene and/or diesel fuels as primary products, and light ends such as tail gas and/or naphtha produced as a byproduct are recycled to the gasification unit or the reactor (e.g., a reformer). The combination of these specific process steps, coupled with the addition of renewable hydrogen, provides a process having high carbon conversion efficiency as output streams that would normally be emitted are recycled to produce additional syngas.

**[0017]** Additionally, the present disclosure provides processes and systems for converting carbon dioxide and produced water to syngas using an electrolysis unit. In some embodiments, the system includes a high temperature co-electrolysis unit (HTCE). The HTCE unit may be configured to electrolyze CO<sub>2</sub> and H<sub>2</sub>O into additional syngas. The HTCE unit can convert CO<sub>2</sub> and water (e.g., the produced water from the Fischer Tropsch reactor) into additional syngas that can be used to produce additional hydrocarbons. For example, the system utilizes the HTCE unit to convert CO<sub>2</sub> emissions generated from the hydrocarbon synthesis processes in combination with water produced from the same processes to syngas. The syngas produced from the HTCE unit can also undergo Fischer Tropsch synthesis to produce more hydrocarbon-based fuels. Additionally, the added energy for the conversion (via co-electrolysis) into additional syngas can be provided from non-carbon based power sources (e.g., green energy sources) which results in reduced total overall GHG emissions with the conversion of the CO<sub>2</sub>.

**[0018]** The systems and processes described herein can drastically reduce CO<sub>2</sub> emissions by incorporating renewable hydrogen in order to enrich the biomass derived syngas, as well as repurposing waste streams and byproducts to produce more hydrocarbon-based fuels per unit biomass converted. In some embodiments, the system may include a HTCE unit to convert produced water and CO<sub>2</sub> into hydrogen, carbon monoxide, and oxygen, a (reverse) water-gas-shift reactor to convert hydrogen, oxygen, and CO<sub>2</sub> into syngas, or combinations thereof. The systems and processes described herein beneficially contribute to the overall carbon efficiency of the process by providing a higher conversion of feedstock into useful product carbon associated to final liquid fuel products. Advantageously, the additional energy for converting CO<sub>2</sub> and produced water into syngas is offset by the improved carbon efficiency of the process as more liquid fuels are produced per unit of biogenic carbon fed to the process. In some embodiments, the additional energy for HTCE conversion of CO<sub>2</sub> and produced water into syngas is supplied from green energy sources, e.g., solar energy, wind power, hydrothermal power, etc. By utilizing green energy sources, no additional CO<sub>2</sub> emissions are added when converting CO<sub>2</sub> and water via direct electrolysis. In some embodiments, the present process preferably uses green energy through high efficiency HTCE electrolysis (95+ % power efficiency) with potential for higher efficiency depending upon the heat available

from the remainder of the system. The CO<sub>2</sub> and produced water—both unwanted byproducts from the hydrocarbon synthesis process—are converted to syngas and subsequently processed into additional hydrocarbon fuel.

**[0019]** Moreover, the process and system described herein utilizes renewable energy and converts byproducts (e.g., produced water and carbon dioxide gas) to provide a sustainable path to reduce the impact of GHGs on the environment by maximizing the biogenic carbon conversion efficiency and utilization of produced water to lower any emitted products. Furthermore, the process and system described herein introduces other non-food biomass feedstocks to replace the primary natural gas feedstock selected for conventional synfuels plant operations. In addition to the carbon and produced water usage advantages of the process, the potential for use of these alternate sources of low-cost biogenic carbon may be valuable in view of the uncertain pricing of natural gas in the longer term and site-specific availability of alternate non-food biomass materials.

**[0020]** In some embodiments, the present disclosure provides a system for producing a hydrocarbon-based fuel. The system includes a biomass feedstock processing unit. The biomass feedstock processing unit is configured to remove waste from a feedstock to produce a conditioned feedstock with controlled physical properties, hence suitable for combustion or gasification. The system includes a gasification unit in communication with the biomass feedstock processing unit. The gasification unit is configured to convert the processed feedstock into a crude syngas. The crude syngas includes carbon dioxide, carbon monoxide, hydrogen, and nitrogen alongside with tars and volatiles. In some embodiments, where pure oxygen is utilized, the crude syngas may not include nitrogen. The system includes a reactor downstream the gasification unit. The reactor is operated at suitable conditions to promote conversion of portions of the syngas to produce a proper ratio of hydrogen to CO with limited CO<sub>2</sub> concentration given the thermodynamically favorable operating conditions for the reverse water gas shift reaction. In some embodiments, the system may include a Heat Recovery Steam Generation (HRSG) system to cool down the hydrogen-enriched syngas. The system may include an acid gas scrubber configured to remove carbon dioxide from the syngas to produce a purified syngas having a hydrogen to carbon monoxide ratio of at least 1.5:1. In some embodiments, the purified syngas is further enriched by combining it with a

hydrogen rich stream, preferably green hydrogen obtained by water electrolysis powered by renewable energy, so as to increase the ratio of H<sub>2</sub> to CO to at least 2:1. The hydrogen enriched syngas thus obtained is then routed to a Fischer Tropsch reactor, wherein the Fischer Tropsch reactor converts the purified syngas into Fischer-Tropsch liquids, water, and tail gas. The produced water from the Fischer Tropsch reactor can be combined with other water purges from the system and treated in a water treatment unit leading to a zero discharge and minimal water intake make up requirement, followed by an electrolysis unit that converts part of the purified water into an oxygen stream and a hydrogen stream. A portion or the whole of the oxygen stream produced from the electrolysis unit is recycled to the gasification unit, the autothermal reformer, or combinations thereof. In some embodiments, the system includes a reverse water-gas shift reactor. A portion of the carbon dioxide removed from the syngas in the scrubber is recycled to the reverse water-gas-shift reactor. In some embodiments, a portion of the hydrogen stream is provided to the reverse water-gas shift reactor. The reverse water-gas shift reactor is configured to produce carbon monoxide that is supplied to the Fischer Tropsch reactor. Alternatively, a portion of the said removed carbon dioxide combined with steam can be converted to additional H<sub>2</sub>:CO ratio syngas in a CO<sub>2</sub> electrolysis unit. Depending on the configuration, the system can achieve at least 65% and up to 95 % carbon conversion of the feedstock into liquid fuel products. In some embodiments, the syngas stream and the hydrogen stream are pressurized prior to being supplied to the Fischer Tropsch reactor. In some embodiments, the tail gas from the Fischer Tropsch reactor is recycled to the reformer. In some embodiments, the system includes a hydrocracker unit, a fractionation unit, isomerization unit, and other hydrocarbon processes, or combinations thereof, configured to upgrade the Fischer-Tropsch liquid into fuel, wherein a byproduct of the hydrocracker unit comprises tail gas, wherein a byproduct of the fractionation unit comprises naphtha. In some embodiments, the tail gas, naphtha, or both, are recycled to the reformer. In some embodiments, the system includes a flue gas scrubber configured to scrub any flue gas generated by the system. In some embodiments, the system includes a carbon dioxide treatment and compression system, wherein carbon dioxide produced from the scrubber and the flue gas scrubber is processed in the carbon dioxide treatment and compression system to produce a purified carbon dioxide stream, wherein the purified carbon dioxide stream is

recycled to the reformer, the reverse water-gas shift reactor, the high temperature co-electrolysis unit, or combinations thereof. In some embodiments, the feedstock comprises one or more of railroad ties, greasewood, corn stover, orchard prunings, forest thinnings, slash, switch grass, wood chips, lignin, and cellulosic material. In some embodiments, the feedstock comprises woody biomass. In some embodiments, the system includes a pre-reformer and an autothermal reforming unit configured to convert a natural gas feedstock into syngas.

**[0021]** In some embodiments, the present disclosure provides a process for producing hydrocarbon-based fuels, which includes gasifying a biomass feedstock to produce a crude syngas stream comprising carbon dioxide, carbon monoxide, and hydrogen alongside with tars and volatiles; reforming the crude syngas stream to produce a hydrogen-enriched syngas stream; separating carbon dioxide from the hydrogen-enriched syngas stream in a separation unit to produce a carbon dioxide stream and a purified syngas stream having a hydrogen to carbon monoxide ratio of at least 1.5:1; combining the purified syngas stream with hydrogen derived from renewable sources so as to enrich the purified syngas to a hydrogen to carbon monoxide ratio of at least 2.1; reacting the purified and hydrogen enriched syngas stream in a Fischer Tropsch reactor to produce Fischer-Tropsch liquids, water, and tail gas; recycling the water produced from the Fischer Tropsch reactor to a zero discharge water treatment unit; and electrolyzing the purified water in the electrolysis unit to produce an oxygen stream and a hydrogen stream. In some embodiments, the process includes purifying the carbon dioxide stream generated from the separation unit to produce a purified carbon dioxide stream. In some embodiments, the process includes recycling the purified carbon dioxide stream to the gasification step, the reforming step, or combinations thereof. In some embodiments, the process includes recycling a portion of the oxygen stream and a portion of the hydrogen stream to the gasification step, the reforming step, or combinations thereof. In some embodiments, the process includes recycling a portion of the hydrogen stream and a portion of the purified carbon dioxide stream to a reverse water-gas-shift reactor and/or a CO<sub>2</sub> electrolysis unit. In some embodiments, the products (e.g., carbon monoxide) from the reverse water-gas-shift reactor and/or a CO<sub>2</sub> electrolysis unit may be fed to the Fischer Tropsch reactor to convert syngas into Fischer-Tropsch liquids. In some embodiments, the process includes processing natural gas in a reformer to produce a second crude syngas stream that is

supplied to the Fischer Tropsch reactor. In some embodiments, the electrolysis unit is powered by solar energy, wind energy, hydroelectric energy, nuclear energy, or tidal energy. In some embodiments, the biomass feedstock comprises one or more of railroad ties, greasewood, corn stover, orchard prunings, forest thinnings, slash, harvesting residues, switch grass, wood chips, lignin, and cellulosic material. In some embodiments, the process includes treating the water produced from the Fischer Tropsch reactor to produce a boiler-quality feed water, wherein the boiler-quality feed water is electrolyzed in the electrolysis unit. In some embodiments, the water from the Fischer Tropsch reactor is treated to remove hydrocarbons and alcoholates.

#### *Definitions and Descriptions*

**[0022]** As used herein, the terms “invention,” “the invention,” “this invention” and “the present invention” are intended to refer broadly to all of the subject matter of this patent application and the claims below. Statements containing these terms should be understood not to limit the subject matter described herein or to limit the meaning or scope of the patent claims below.

**[0023]** As used herein, the meaning of “a,” “an,” or “the” includes singular and plural references unless the context clearly dictates otherwise.

**[0024]** As used herein, “carbon conversion efficiency” refers to the amount of carbon content in the feedstock that is converted into hydrocarbon fuel.

**[0025]** As used herein, “unit” refers to a part of a system, and may for example comprise a unit operation, a system, or group of unit operations.

**[0026]** As used herein, “stream” refers any fluid or solid moving, directly or indirectly, from one location to another.

**[0027]** As used herein, “syngas” may comprise a combination of carbon monoxide, hydrogen, carbon dioxide and possibly other components such as, without limitation, water vapor, sulfur- or nitrogen-containing compounds, methane and other alkanes, hydrocarbons, acid gases, halogens and particulates.

**[0028]** As used herein, the meaning of “room temperature” can include a temperature of from about 15 °C to about 30 °C, for example about 15 °C, about 16 °C, about 17 °C, about

18 °C, about 19 °C, about 20 °C, about 21 °C, about 22 °C, about 23 °C, about 24 °C, about 25 °C, about 26 °C, about 27 °C, about 28 °C, about 29 °C, or about 30 °C.

**[0029]** All ranges disclosed herein are to be understood to encompass both endpoints and any and all subranges subsumed therein. For example, a stated range of “1 to 10” should be considered to include any and all subranges between (and inclusive of) the minimum value of 1 and the maximum value of 10; that is, all subranges beginning with a minimum value of 1 or more, e.g., 1 to 6.1, and ending with a maximum value of 10 or less, e.g., 5.5 to 10.

### *Process Configuration*

**[0030]** **FIG. 1** shows a schematic diagram of a system for producing hydrocarbon fuels according to some embodiments of the present disclosure. The system 100 provides an overall system for producing hydrocarbon-based fuels with high carbon conversion efficiency. The system 100 provides a continuous process for converting biomass and, optionally natural gas, into synthesis gas (“syngas”). The syngas is ultimately converted to a hydrocarbon-based fuel, e.g., jet fuel, via hydrocarbon synthesis utilizing the Fischer Tropsch process and, optionally, fuel upgrading. As described above, the conversion of biomass to liquid is often referred to as “BTL” and the conversion of natural gas to liquid is often referred to as “GTL”. In some aspects, the system incorporates both BTL and GTL processes to produce syngas.

**[0031]** In some embodiments, the system 100 may be configured to convert feedstock 105 (e.g., biomass) into hydrocarbon-based fuels. The system 100 may include a feedstock processing unit 110. The feedstock 105 may be supplied to the feedstock processing unit 110. In some embodiments, the feedstock processing unit 110 can be a biomass feedstock processing unit. The feedstock processing unit 110 is configured to separate materials from feedstock for additional processing. In some embodiments, the feedstock processing unit 110 is configured to adjust the feedstock physical properties, namely its moisture content and maximum particle size, as well as to separate unwanted materials from feedstock for additional processing. For example, non-biogenic derived carbon materials and non-carbonaceous materials (e.g., waste material) may be removed from the feedstock. In the feedstock processing unit 110, the waste material may be sized, separated, and processed to remove materials that are not useful in the process, or which might reduce its efficiency. For

example, the feedstock processing unit 110 removes metals, inorganic materials, and other materials to produce a processed feedstock 115.

**[0032]** In some embodiments, the bulk of the feedstock comprises biomass (e.g., railroad ties or another cellulosic material) and, optionally, a small amount of natural gas. In some embodiments, the biomass feedstock may include corn stover, bagasse, switch grass, forest thinnings, slash, wood chips, lignin, or any other carbohydrate, cellulosic materials, or combinations thereof. In some embodiments, the biomass may comprise one or more of railroad ties, greasewood, corn stover, forest thinnings, slash, or orchard pruning.

**[0033]** The system 100 may include a gasification unit 120 that receives the processed feedstock 115. The gasification unit 120 can be a biomass gasification unit. The gasification unit 120 converts the processed feedstock 115 into a crude syngas stream 125. For example, the gasification unit 120 converts processed biomass into the crude syngas stream 125 by one or more steps of steam reformation, carbon oxidation, or gasification, and hydrocarbon reformation. The crude syngas stream 125 produced from the gasification unit 120 may include carbon monoxide, hydrogen, carbon dioxide, argon, nitrogen, tars, and volatiles.

**[0034]** The system 100 may include a high temperature, non-catalytic reforming unit 130 for the partial oxidation of methane and other hydrocarbons contained in the crude syngas stream 125 with an oxygen-containing gas. The crude syngas stream 125 produced is a high biogenic content syngas. In some embodiments, the reforming unit 130 comprises a partial oxidation reformer, a steam reformer, an autothermal reformer, or combinations thereof (although other reformer types can also be used). In some embodiments, the reforming unit 130 utilizes oxygen separated from air using cryogenic separation, pressure-swing absorption, membrane separation (e.g., ion-transport membrane, ITM), and combinations thereof. In some cases, the partial oxidation reformer utilizes an oxidizing gas selected from the group consisting of air, oxygen-enriched air, pure oxygen, and combinations thereof. The oxygen supplied to the reforming unit 130 can be pure oxygen to reduce the amount of energy needed to filter unwanted components (e.g., nitrogen from air). In some embodiments, the oxygen supplied to the reforming unit 130 is provided from the water electrolysis unit 155 as further discussed below. In some embodiments, the waste heat from the reforming unit 130 can be recovered in a waste heat recovery unit and recycled to the reforming unit 130 or other units



in the system 100. In some embodiments, processed syngas stream 135 from the reforming unit 130 can be processed in a syngas conditioning unit for further purification of the syngas before being combined with green or renewable hydrogen and supplied to the Fischer Tropsch reactor.

**[0035]** In some embodiments, the processed syngas stream 135 can be pressurized in one or more compressor(s) 140. The compressor(s) 140 are configured to pressurize the processed syngas stream 135 to a predefined level to produce a compressed syngas stream 145. In some embodiments, the final pressure of the compressed syngas stream 145 may be in a range acceptable for the Fischer Tropsch synthesis process.

**[0036]** The compressed syngas stream 145 can be sent to a scrubber 150 to remove contaminants (e.g., carbon dioxide and other acid gases) prior to being supplied to the Fischer Tropsch reactor 180. In some embodiments, the scrubber 150 is a carbon dioxide scrubber. The scrubber 150 is configured to remove contaminants from the compressed syngas stream 145 to produce a purified syngas stream 151. For example, the scrubber 150 can remove carbon dioxide and other contaminants that can reduce performance of the Fischer Tropsch reactor. The scrubber 150 can receive the compressed syngas stream 145 and a solvent or a solution (e.g., an alkaline solution, an ammine, cold methanol or other) to absorb contaminants from the compressed syngas stream 145 by means of the reversible chemical absorption process. Loaded solvent from the absorber can be regenerated in a stripping unit where carbon dioxide gets released and the lean solvent recovered and circulated in closed circuit to the absorber..

**[0037]** The carbon dioxide stream 152 separated from the compressed syngas stream 145 can be supplied to a carbon dioxide treatment and compression system 160. The carbon dioxide treatment and compression system 160 can remove contaminants from the carbon dioxide stream 152 to produce purified carbon dioxide 165. The purified carbon dioxide 165 produced from the carbon dioxide treatment and compression system 160 can be either recycled to other units in the system 100 to produce additional syngas or routed to a CO<sub>2</sub> sequestration well. Within limits given by the mass and energy balance, the purified carbon dioxide 165 from the carbon dioxide treatment and compression system 160 can be recycled to the dry reforming unit 130, the RWGS reactor, the HTCE unit, or combinations thereof.

This recycle stream utilizes carbon dioxide that would be typically emitted as flue gas, and reuses carbon dioxide to produce additional syngas.

**[0038]** In some embodiments, a portion of the purified carbon dioxide 166 from the carbon dioxide treatment and compression system 160 can be processed in a (reverse) water-gas-shift reactor 170. This CO<sub>2</sub> combined with H<sub>2</sub> 157 from the water electrolysis unit 155 yields a syngas stream 171 for further processing in the FT reactor system 180. In some embodiments, reverse water-gas-shift reactor 170 is a HyCOgen unit produced by Johnson Matthey. The reverse water-gas-shift reactor 170 converts recovered CO<sub>2</sub> and H<sub>2</sub> back to CO and H<sub>2</sub>O that can be used in the system 100. Purified and compressed syngas stream 151 from the carbon dioxide treatment and compression system 160 is also supplied to the FT reactor system 180 where is combined with other syngas input streams and H<sub>2</sub> 157 produced by the water electrolysis unit 155. In some embodiments, the targeted H<sub>2</sub>/CO ratio may be in the range of 0.5 to 10.0.

**[0039]** The purified syngas stream 151 may be supplied to the Fischer Tropsch reactor 180 as either the main or only carbon-containing feedstock. In some embodiments, a secondary syngas stream 171 is also a feedstock for the Fischer Tropsch reactor 180. In addition, a fraction of the water electrolysis hydrogen production is also combined with the overall syngas stream for hydrocarbon synthesis. The Fischer Tropsch reactor 180 synthetically produces higher hydrocarbon liquids by catalytically converting syngas in a strongly exothermic process. Therefore, the FT reactor may require substantial heat removal, which is normally accomplished via medium pressure steam production from boiler feed water vaporization. The Fischer Tropsch reactor 180 produces a mixture of linear paraffinic hydrocarbon molecules, with carbon numbers varying between C1 and C30 or higher as the main product and produced water as a byproduct. The FT reaction is a heterogeneously catalyzed reaction, characterized by gas phase reactants and a combination of liquid and gaseous products which are separately collected as medium F-T liquid (MFTL) and heavy F-T liquid (HFTL), water, and F-T tail gas. The F-T tail gas 185, typically containing a mixture of unreacted hydrogen and carbon monoxide, as well as methane and CO<sub>2</sub> by-products of the reaction, can be recycled to other units in the system where can be reformed back to additional syngas. For example, the F-T tail gas 185 can be recycled to the reforming unit

130. In some embodiments, the system may include a hydrocracker unit 190 and/or fractionation unit 195 to upgrade the F-T liquids. For example, the hydrocracker unit 190 employs a high temperature, high pressure catalytic process that upgrades the HFTL and MFTL hydrocarbon streams 181 into a transportation fuel or a blending component meeting chemical and physical properties. The tail gas 191 produced from the hydrocracker unit 190 and the naphtha 196 produced from the fractionation unit 195 can be recycled to the system (e.g., to the reforming unit 130).

**[0040]** The system 100 includes a water electrolysis unit 155. The water produced from the aforementioned units (e.g., gasifier, Fischer Tropsch reactor, etc.) in the system 100 can be processed in a water treatment unit and then supplied to the water electrolysis unit 155. The water treatment unit can produce boiler-quality water that is supplied to the water electrolysis unit 155, as well as to several cooling or heat recovery systems whereby steam is produced. For example, the purified water stream 182 from the Fischer Tropsch reactor 180 can be supplied to the water electrolysis unit 155. The water electrolysis unit 155 can convert the purified water into an oxygen stream 156 and a hydrogen stream 157, which can be supplied to other units in the system 100. For example, the oxygen stream 156 produced from the water electrolysis unit 155 can be supplied to the gasification unit 120, the reforming unit 130, the reverse water-gas-shift reactor 170, or combinations thereof. In some embodiments, the oxygen stream 156 prior to being supplied to the reverse water-gas-shift reactor 170. The hydrogen stream 157 produced from the water electrolysis unit 155 can be supplied to the reverse water-gas-shift reactor 170. In some embodiment, the hydrogen stream 157 is compressed prior to being supplied to the reverse water-gas-shift reactor 170. The reverse water-gas-shift reactor 170 may be configured to provide a catalyzed process to convert hydrogen and CO<sub>2</sub> into carbon monoxide (CO), which is combined with additional hydrogen to form syngas. The syngas 171 produced from the reverse water-gas-shift reactor 170 can then be supplied to the Fischer Tropsch reactor 180 to produce additional hydrocarbon fuel.

**[0041]** In some embodiments, the electrolysis unit is powered by solar energy, wind energy, hydroelectric energy, nuclear energy, or tidal energy. In some embodiments, the process includes scrubbing the carbon dioxide stream in a carbon dioxide scrubber to produce purified carbon dioxide, wherein the purified carbon dioxide is electrolyzed in the electrolysis

unit. In some embodiments, the process includes boiling the water produced from the Fischer Tropsch reactor to produce a boiler-quality feed water, wherein the boiler-quality feed water is electrolyzed in the electrolysis unit. In some embodiments, the process includes reacting the additional syngas in the Fischer Tropsch reactor to produce additional hydrocarbons. In some embodiments, the process includes sequestering additional CO<sub>2</sub> produced in the process.

**[0042]** In some embodiments, the approximate additional power for electrolysis of water produced in the system ranges from 30 MW to 80 MW per ton of hydrogen produced from the reverse fuel cell or electrolysis unit. If energy for electrolysis is supplied from a conventional energy source, e.g., natural gas, approximately 450 gr CO<sub>2</sub>/kWh is generated in an “efficient” combined cycle mode. However, if green energy is employed (e.g., solar power), the CO<sub>2</sub> emissions associated with power generation is less than 100 gr CO<sub>2</sub>/kWh, less than 90 gr CO<sub>2</sub>/kWh, less than 50 gr CO<sub>2</sub>/kWh, or less than 20 gr CO<sub>2</sub>/kWh, with highly efficient sources as low 17.5 gr CO<sub>2</sub>/kWh. With respect to CO<sub>2</sub> electrolysis, the power requirement may be from 0.05 to 0.80 MWh/ton, e.g., from 0.05 to 0.70 MWh/ton, from 0.10 to 0.70 MWh/ton, from 0.15 to 0.60, from 0.20 to 0.50 MWh/ton, from MWh/ton from 0.20 to 0.40 MWh/ton, or about 0.232 MWh/ton, and if power is supplied by green energy source as opposed to conventional natural gas sources, there is again a reduction in overall CO<sub>2</sub> emissions.

**[0043]** Electric power generated on site (either by using steam generated on site to power steam turbine generators or by installing Solar or Wind turbine power generation) may be used for a source of power to drive electrolysis of water to produce portions of the hydrogen and oxygen needed for plant process operations. Additional hydrogen, beyond what is available in the biomass feedstock is required in the biomass gasification, conversion to liquids and associated cleanup processes. Since the electrolysis process splits water into its components of hydrogen and oxygen, it provides some of the oxygen needed in overall plant operations. In some embodiments, the processes and systems described herein use renewable energy resources (e.g., solar, wind, etc.) to provide power for individual units in the system. Additionally, waste heat is recovered where economically viable to generate electric power for reuse in the system.

**[0044]** FIG. 2 shows a schematic diagram of a hydrocarbon synthesis process integrated with a CO<sub>2</sub> electrolysis unit in accordance with some embodiments of the present invention. As shown in FIG. 2, the process incorporates both BTL and GTL processes to produce syngas. As discussed herein, a system and process are disclosed for the combustion of a wide variety of hydrocarbon feedstocks to produce thermal energy, liquid fuels, and other valuable products with little or no emissions. The hydrocarbon and solid carbon-containing feeds, such as natural gas and biomass, are processed, through reforming and gasification and oxidation respectively, in order to produce syngas. The syngas is fed to a Fischer Tropsch synthesis process for conversion into hydrocarbons and optionally upgraded to form fuels, e.g., diesel fuel or other liquid hydrocarbons. The present system/process minimizes environmental emissions by employing an electrolysis unit to reduce CO<sub>2</sub> emissions while at the same time improving overall carbon efficiency and forming additional hydrocarbons. The electrolysis process preferably is at least partially powered by green energy.

**[0045]** In some embodiments, the bulk of the feedstock comprises biomass (e.g., railroad ties or another cellulosic material) and, optionally, a small amount of natural gas. In some aspects, the biomass feedstock may include switch grass, forest thinnings, slash, wood chips, lignin, or any other carbohydrate and/or cellulosic materials. The biomass may comprise one or more of railroad ties, greasewood, corn stover, forest thinnings, slash, or orchard prunings. For example, Unit 220 (Biomass Feedstock) provides a biomass feedstock that is gasified to form syngas.

**[0046]** As shown in FIG. 2, natural gas is supplied to the system via Unit 200 (Gas Distribution Network). The natural gas from Unit 200 may be split into a portion for conversion to hydrocarbon-based fuels (“feed natural gas” sent to Unit 210) and a portion for turbine-based electricity (“power natural gas” sent to Unit 500). A natural gas pre-heater and Unit 210 (e.g., sulfur removal unit) heats the natural gas and removes sulfur-containing compounds to provide a natural gas feedstock that is utilized to produce syngas. The amount of natural gas for turbine-based electricity varies depending on the amount of green energy, e.g., solar energy, available for the process. In some embodiments, at least 20 MW, e.g., at least 40 MW or at least 60 MW, of solar power is available for an 8-hour period to supplement the total electric power requirement, which may range from 50 to 200 MW, e.g.,

from 50 to 200 MW, from 60 to 180 MW, from 75 to 160 MW, from 80 to 150 MW, from 90 to 140 MW, from 100 to 130 MW, or about 128.15 MW. Geographic considerations may impact the supplemental green energy requirements. In some embodiments, the green energy source may be one or more of wind energy, hydroelectric energy, nuclear energy, tidal energy, or another source of green energy. In some embodiments, additional natural gas is utilized in the process to provide electricity during the production process, e.g., 16-hr period, when direct green energy, e.g., solar energy, is not available.

**[0047]** As discussed above, Unit 200 provides a natural gas distribution network that distributes the natural gas to Unit 210 and/or Unit 500. This configuration advantageously minimizes the capital for solar energy storage in the process. In some aspects, the process produces synthetic jet fuel with at least 20% less, e.g., at least 40% less, or at least 60% less, overall CO<sub>2</sub> emission than the emissions associated with conventional refining of crude oil. As will be appreciated, there are numerous variations in this configuration based on the amount of natural gas, amount of solar power, and selection of the fraction of natural gas and biomass in the feed.

**[0048]** Referring back to Unit 210, the natural gas feedstock is combined with the gas phase products (e.g., unconverted H<sub>2</sub> and CO) and H<sub>2</sub> (produced via electrolysis in Unit 320) in this particular configuration. In some embodiments, the natural gas feedstock is combined with the gas phase products and H<sub>2</sub> in Unit 260A (Autothermal Reforming Unit) to produce syngas, which is subsequently fed to Unit 205B (Syngas Treatment Unit). As shown, a CO<sub>2</sub> rich stream is optionally directed from the syngas treatment unit 205B to Unit 363 (CO<sub>2</sub> absorber unit), described in more detail below. The syngas that is converted to hydrocarbons in Unit 310 (Fischer Tropsch Unit) comprises light hydrocarbons produced via Fischer Tropsch synthesis and undergoes upgrading (e.g., a hydrocracking and/or isomerization step) in Unit 240 to produce the final product, e.g., synthetic jet fuel. Other configurations can use H<sub>2</sub> derived from CO<sub>2</sub> electrolysis in Unit 360 (CO<sub>2</sub> Electrolysis Unit), or more conventional methods based on H<sub>2</sub> separation from the effluent syngas from either the reforming unit 260A or gasification unit 230.

**[0049]** In some embodiments, Unit 210 (Natural Gas Feedstock) produces an effluent that is directed to the reformer, Unit 260A. In some aspects, Unit 260A is an Autothermal

Reforming Unit (ATR). The ATR converts the effluent from Unit 210, with steam and oxygen, to produce syngas. This syngas may comprise undesirable constituents such as, e.g., reactive nitrogen and undesirably high levels of CO<sub>2</sub>. Typically, syngas treatment comprises removal units for removing or converting these undesirable constituents. In some embodiments, the H<sub>2</sub>/CO ratio is in the range of 0.5 to 10.0.

**[0050]** In some embodiments, biomass is delivered in Unit 220 (Biomass Feedstock) and processed in Unit 225 (Biomass Feedstock Processing) for size reduction and water removal. The treated biomass then undergoes gasification using any suitable conversion technology which is energy efficient, minimizes CO<sub>2</sub> and produces a suitable syngas with respect to the H<sub>2</sub>/CO ratio, e.g., typically from 0.5 to 1.0, e.g., 0.55, 0.60, 0.65, 0.70, 0.75, 0.80, 0.85, 0.90, 0.95, or 1.0. In some embodiments, the H<sub>2</sub>/CO ratio is in the range from 0.8 to 1.0. Biomass gasification produces large amounts of CO<sub>2</sub> due to the high oxygen content of the feed. Consequently, the biomass derived syngas passes through Unit 205A (CO<sub>2</sub> Removal Unit). The CO<sub>2</sub> is then passed through Unit 363 (CO<sub>2</sub> Absorber Unit) to remove the trace hydrocarbons and CO which is contained in the scrubbed CO<sub>2</sub> to produce purified CO<sub>2</sub>.

**[0051]** The resulting syngas, with greatly diminished CO<sub>2</sub> content, is then combined with the syngas from unit 205B and hydrogen from unit 320 (water electrolysis unit), with the combined syngas sent to Unit 310 for Fischer Tropsch synthesis. After Fischer Tropsch synthesis, the products comprise a range of hydrocarbons—from methane to heavy waxes—with the heaviest alkanes having boiling points in excess of 800 °F (427 °C). In some embodiments, the light hydrocarbons (typically C<sub>1</sub> to C<sub>8</sub>) as well as the unreacted syngas is sent to Unit 425 (Turbine/Heater) where a fraction of the product is used as fuel, e.g., for a turbine and process fired heaters (i.e., Units 110, 250, 260A and 240). In some embodiments, the remaining product that is not used as fuel, is recycled back to Units 250 and 260A for conversion to additional syngas.

**[0052]** In some embodiments, the heavier Fischer Tropsch products (C<sub>9+</sub>) are sent to the Unit 240 (Fuel Upgrading Unit) and combined with H<sub>2</sub> for processing into the final hydrocarbon products, e.g., jet fuel or diesel products, via hydro-processing. In Unit 240, some material may be converted to light hydrocarbons contained in the Fuel Upgrading Unit

purge gas which is combined with the Fischer Tropsch purge gas and recycled to generate further syngas.

### **CO<sub>2</sub> Generation**

**[0053]** FIG. 2 shows exemplary CO<sub>2</sub> emissions for various units in the hydrocarbon synthesis process. In some embodiments, the major CO<sub>2</sub> generation sources in the above process/system are as follows:

- Natural gas turbine flue gas (Unit 500);
- Process Heater flue gas (Unit 425);
- CO<sub>2</sub> removed from biomass derived syngas (Unit 205A); and
- ATR derived syngas (Unit 205B).

**[0054]** In the above configuration of the process/system, the CO<sub>2</sub> generated via the natural gas turbines directly emitted as flue gas (Unit 500) is the largest source of CO<sub>2</sub> emissions. Unit 500 is responsible for a bulk of the atmospheric emissions as shown in the central highlighted box of FIG. 2. The second largest source of CO<sub>2</sub> emissions is the CO<sub>2</sub> removed from the biomass derived syngas (Unit 205A). The CO<sub>2</sub> emissions from Unit 205A constitutes the bulk of the sequestered CO<sub>2</sub>. The flue gas CO<sub>2</sub> (from the internally generated fuel gas) passes through a treatment system (Unit 235) to capture additional CO<sub>2</sub> for sequestration. The uncaptured CO<sub>2</sub> from Unit 235 adds a small fraction to atmospheric emissions. In some embodiments, a fraction of the total CO<sub>2</sub> generated is transferred to the CO<sub>2</sub> electrolysis unit 360 and subsequently converted to syngas through the consumption of electric power.

### **Integration of CO<sub>2</sub> and Water Electrolysis**

**[0055]** As discussed herein, in some embodiments, the present invention provides a process for converting carbon dioxide and produced water to syngas in a hydrocarbon production process. The process may include processing natural gas in an autothermal reforming unit to form a first syngas stream, processing a biomass feedstock in a gasification unit to form a second syngas stream, treating the first and second syngas streams in a syngas treatment unit to produce a feed syngas stream, wherein the syngas treatment unit removes carbon dioxide from either or both the first and second syngas streams, reacting the feed syngas stream in a Fischer Tropsch reactor to produce hydrocarbons and water, and



electrolyzing the carbon dioxide and water (e.g., after purification) in an electrolysis unit to produce carbon monoxide and hydrogen, which can be sent to the FT reactor. In some aspects, the electrolysis unit is powered by a green energy source. The green energy source may comprise one or more of solar energy, wind energy, hydroelectric energy, nuclear energy, or tidal energy. In some embodiments, at least 40 MW of solar power is supplied to the electrolysis unit over an 8-hour period.

**[0056]** In some aspects, the process further comprises scrubbing the carbon dioxide removed from the syngas treatment unit in a carbon dioxide scrubber to produce purified carbon dioxide, wherein the purified carbon dioxide is electrolyzed in the electrolysis unit. In some aspects, the process further comprises treating (e.g., boiling) the produced water from the Fischer Tropsch reactor to produce a boiler-quality feed water, wherein the boiler-quality feed water is electrolyzed in the electrolysis unit to produce carbon monoxide. In some aspects, the process further comprises sending the carbon monoxide to the Fischer Tropsch reactor to produce additional hydrocarbons.

**[0057]** When applying GTL and BTL technology for hydrocarbon synthesis, the amount of total CO<sub>2</sub> emissions is dependent on many factors. For example, the amount of total CO<sub>2</sub> emissions is primarily dependent upon the natural gas and biomass feed rates, carbon conversion efficiency, as well as the CO<sub>2</sub> emissions associated with the electric power for the conversion process. In some aspects, the carbon conversion efficiency can be relatively low allowing for a significant fraction of the feed stock energy to be converted to electric power through combustion processes. However, in this scenario, the total CO<sub>2</sub> emissions can be relatively high unless the process utilizes a non-fossil fuel source such as, e.g., a biomass. Unless CO<sub>2</sub> sequestration is employed to mitigate CO<sub>2</sub> emissions, the total CO<sub>2</sub> emissions associated with power and fuel production can exceed total allowable CO<sub>2</sub> emission thresholds.

**[0058]** In some embodiments, the present invention utilizes green energy, e.g., solar energy, as a source of electric power to provide energy for the conversion of CO<sub>2</sub> into synthesis gas and subsequently into transportation fuels. Many process configurations are contemplated to demonstrate that electrolysis of CO<sub>2</sub> and produced water into synthesis gas and subsequent conversion into transportation fuels reduces overall CO<sub>2</sub> emissions. For

example, sequestering of the CO<sub>2</sub> can be co-applied to the CO<sub>2</sub> mitigation. However in many locations of the process, sequestration may not be a viable option due to the requirements for a pipeline or relatively low-cost transportation vector. The conversion of CO<sub>2</sub> and steam to syngas affords the opportunity to use electricity to convert the carbon and hydrogen in unwanted byproducts into transportation fuels (energy storage). The CO<sub>2</sub> emissions associated with this added electric power for conversion is considerably less than the CO<sub>2</sub> which would otherwise be emitted without the electrolysis system.

**[0059]** FIG. 2 shows two potential sources for CO<sub>2</sub>/water electrolysis. In some embodiments, Unit 360 co-processes CO<sub>2</sub> and water to produce syngas and oxygen, while Unit 320 processes only water to make H<sub>2</sub> and O<sub>2</sub>. In some embodiments, Unit 320 can provide a source of H<sub>2</sub> for the process. Alternatively, H<sub>2</sub> can be separated from the ATR syngas using recovery techniques. The trade-offs between the source for H<sub>2</sub> involves the preferences for the carbon balance and energy consumption.

**[0060]** In some embodiments, the system described herein includes a partial oxidation reformer to convert natural gas to synthetic gas comprising hydrogen and carbon monoxide, a biomass gasifier to convert various types of biomass materials into a synthetic gas containing primarily hydrogen and carbon monoxide, an electrolysis unit to convert water to yield hydrogen and oxygen gases, an optional desalination system to provide purified water to the electrolysis unit, a reverse water-gas shift reactor to convert carbon dioxide and hydrogen into carbon monoxide and water, a syngas processing system to condition and purify the syngas, a Fischer-Tropsch reactor for converting synthetic gases to liquid hydrocarbon fuels, and a fuel upgrading system to further remove carbon dioxide from the liquid hydrocarbon fuels. The system may include solar panels to convert sunlight into electrical power to provide power to units in the system (e.g., the electrolysis unit) and a steam turbine generator system for production of electric power from waste heat of gasification and gas-to-liquids conversion systems. The system recycles naphtha and/or carbon dioxide produced in natural gas and biomass to liquids processes to the partial oxidation gasifier for conversion to liquid fuels. In some embodiments, the (reverse) water-gas shift reactor can be replaced with a carbon dioxide electrolysis system to convert carbon dioxide to syngas, which is sent to the Fischer Tropsch reactor to produce additional liquid hydrocarbon fuels. Both of these options for

recycling CO<sub>2</sub> have an impact of the electric power required. The reverse water gas shift alternative increases the consumption of hydrogen which is produced via water electrolysis whereas the CO<sub>2</sub> electrolysis is a direct consumer of electric power. Therefore, a trade-off between the overall carbon efficiency of the system and the power input per unit synthetic fuel produced. Depending on the carbon intensity of the power available, CO<sub>2</sub> recycling via one or other option may be more or less attractive from a synthetic fuel carbon intensity point of view.

*Example*

**[0061]** The CO<sub>2</sub> emissions can be compared for each of the BTL and GTL process configurations by using the Green House Gas emission factor (GHG-CO<sub>2</sub>), which can be measured by methods known to one skilled in the art. As shown in Table 1, in conventional refinery operations, the amount of CO<sub>2</sub> emitted per megajoule (MJ) of fuel energy is typically from 50 to 500 CO<sub>2</sub>/MJ fuel produced, or approximately 89.12 gr CO<sub>2</sub>/MJ fuel produced. This is sometimes referred to as the CO<sub>2</sub> life cycle assessment. There are numerous factors contributing to the total CO<sub>2</sub> emissions per unit of fuel energy as shown in Table 1. For example, factors such as the biogenic uptake, upstream biomass, process solar emissions, natural gas turbine emissions, among others, each contribute to the CO<sub>2</sub> emissions per unit value of product energy, e.g., SPK. In the BTL/GTL process shown in **FIG. 2**, the major contributors to CO<sub>2</sub> emissions include the actual combustion of the SPK and the electric energy associated with the natural gas turbines.

**[0062]** It has now been discovered that the inclusion of CO<sub>2</sub> sequestration with CO<sub>2</sub>/water electrolysis, e.g., Unit 360, leads to a substantial reduction of the overall CO<sub>2</sub> emissions when compared to conventional refinery practices. *See* Table 1 (89.12 gr CO<sub>2</sub>/MJ SPK in Baseline Petroleum Fuel; 59.84 gr CO<sub>2</sub>/MJ SPK in Baseline operation which uses natural gas turbine electric power and CO<sub>2</sub> electrolysis combined with CO<sub>2</sub> sequestration). In this scenario, the primary CO<sub>2</sub> reduction is due to the larger amount of CO<sub>2</sub> undergoing sequestration 323,970 MTPY (metric tons per year) as compared to the amount of CO<sub>2</sub> undergoing electrolysis (148,900 MTPY). The use of flue gas scrubbers to capture CO<sub>2</sub> from the combustion process

(Unit 235) also helps mitigate the overall CO<sub>2</sub> emission levels, especially when the energy for CO<sub>2</sub> capture is in the range of 700-800 kcal/kg CO<sub>2</sub> collected.

**[0063]** In one embodiment, the present invention uses solar energy to reduce the total electric power generation from the natural gas turbine to further mitigate the GHG-CO<sub>2</sub> emissions by reducing the total CO<sub>2</sub> emissions associated with power generation. For example, Table 1 provides the operation with natural gas turbines and 40 MW of solar power compared to Baseline Petroleum Fuel. In some embodiments, providing solar energy at 40 MW for 8 hr/day further reduces the overall CO<sub>2</sub> emissions by over 60% compared to the petroleum base line (33.9 gm CO<sub>2</sub>/MJ fuel compared to the 89.12 gm CO<sub>2</sub>/MJ fuel value in the base line case). This reduction is due to the low GHG-CO<sub>2</sub> emissions associated with solar power (e.g., less than 100 gm CO<sub>2</sub>/kwh, less than 50 gm CO<sub>2</sub>/kwh, or less than 20 gm CO<sub>2</sub>/kwh, optionally on the order of 17.5 gm CO<sub>2</sub>/kwh) as compared to the CO<sub>2</sub> emissions from natural gas turbines, which can be as high as 420 gm CO<sub>2</sub>/kwh. For example, the average CO<sub>2</sub> emissions from power generated on the US Grid is in the range of 500-600 gm CO<sub>2</sub> emitted per kwh. Solar, wind and hydroelectric is considerably less, e.g., in the range of 17.5 to 90 gm CO<sub>2</sub> emitted per kwh. Consequently, supplying this electric power from green sources allows for the added production of product while reducing the overall GHG-CO<sub>2</sub> emissions to the levels (30-60% less than conventional refineries which are in the range of 89.12 gm CO<sub>2</sub>/MJ fuel).

<b>TABLE 1</b>			
Life Cycle Component	Baseline Petroleum Fuel (gCO <sub>2</sub> e/MJ)	Operation (gCO <sub>2</sub> e/MJ for 24 h NG Power)	Operation (gCO <sub>2</sub> e/MJ for 16/8h NG Power and 40 MW Solar)
Biogenic Uptake		-164	-164
Upstream Process Carbon NG	8.00	27.9	23.62
Upstream Biomass		1.4	1.4
Process Solar Emissions		-	1.54
NG Turbine Emissions	7.00	119	97.8
Process Emissions with Scrubber		3.64	3.64
Transportation/Distribution	1.00	1	1
Jet Combustion	73.16	70.3	70.3
Total	89.16	59.84	33.9

Reduction (%)		32.88 % Less	61.98 % Less
---------------	--	--------------	--------------

**[0064]** While the invention has been described in detail, modifications within the spirit and scope of the invention will be readily apparent to those of skill in the art. In view of the foregoing discussion, relevant knowledge in the art and references discussed above in connection with the Background and Detailed Description, the disclosures of which are all incorporated herein by reference. In addition, it should be understood that embodiments of the invention and portions of various embodiments and various features recited below and/or in the appended claims may be combined or interchanged either in whole or in part. In the foregoing descriptions of the various embodiments, those embodiments which refer to another embodiment may be appropriately combined.

**We Claim:**

1. A system for producing a hydrocarbon-based fuels, the system comprising:
  - a biomass feedstock processing unit configured to remove waste from a feedstock to produce a processed feedstock;
  - a gasification unit in communication with the biomass feedstock processing unit, wherein the gasification unit is configured to convert the processed feedstock into syngas comprising carbon dioxide, carbon monoxide, and hydrogen;
  - a reactor downstream from the gasification unit, wherein the reactor is operated at suitable conditions to promote conversion of portions of the syngas to produce a proper ratio of hydrogen to CO;
  - a scrubber in communication with the reactor, wherein the scrubber removes carbon dioxide from the syngas to produce a purified syngas having a hydrogen to carbon monoxide ratio of at least 1.5:1;
  - a Fischer Tropsch reactor for receiving the purified syngas, wherein the Fischer Tropsch reactor converts the purified syngas into Fischer-Tropsch liquids, water, and tail gas; and
  - an electrolysis unit configured to receive the water from the Fischer Tropsch reactor, wherein the electrolysis unit converts the water into an oxygen stream and a hydrogen stream;
    - wherein a portion of the oxygen stream is recycled to the gasification unit, the reactor, or combinations thereof; and
    - wherein the system achieves at least 90 % carbon conversion of the feedstock.
2. The system of claim 1, further comprising a reverse water-gas shift reactor, wherein a portion of the carbon dioxide removed from the syngas in the scrubber is recycled to the reverse water-gas shift reactor.
3. The system of claim 2, wherein a portion of the hydrogen stream produced by the electrolysis unit is provided to the reverse water-gas shift reactor, wherein the reverse water-gas shift reactor is configured to produce carbon monoxide that is supplied to the Fischer Tropsch reactor.

4. The system of claim 3, wherein the syngas streams and the hydrogen stream are pressurized prior to being supplied to the Fischer Tropsch reactor.
5. The system of claim 1, wherein the tail gas from the Fischer Tropsch reactor is recycled to the reactor.
6. The system of claim 1, further comprising a hydrocracker unit, a fractionation unit, an isomerization unit, or combinations configured to upgrade the Fischer-Tropsch liquids into fuel, wherein a byproduct of the hydrocracker unit comprises tail gas, wherein a byproduct of the fractionation unit comprises naphtha.
7. The system of claim 6, wherein the tail gas, naphtha, or both, are recycled to the reactor.
8. The system of claim 2, further comprising a flue gas scrubber configured to scrub any flue gas generated by the system, wherein the reactor is a dry reformer.
9. The system of claim 8, further comprising a carbon dioxide treatment and compression system, wherein carbon dioxide produced from the scrubber and the flue gas scrubber is processed in the carbon dioxide treatment and compression system to produce a purified carbon dioxide stream, wherein the purified carbon dioxide stream is recycled to the dry reformer, the reverse water-gas shift reactor, a CO<sub>2</sub> electrolysis unit, or combinations thereof.
10. The system of claim 1, wherein the feedstock comprises one or more of railroad ties, greasewood, corn stover, orchard prunings, forest thinnings, slash, switch grass, wood chips, lignin, and cellulosic material.
11. The system of claim 1, wherein the feedstock comprises woody biomass.
12. The system of claim 1, further comprising a pre-reformer and an autothermal reforming unit configured to convert a natural gas feedstock into syngas.

13. The system of claim 1, further comprising a CO<sub>2</sub> electrolysis unit configured to convert a portion of the carbon dioxide and water removed from the system into carbon monoxide and hydrogen.
14. A process for producing a hydrocarbon-based fuel, the process comprising the steps of:  
gasifying a biomass feedstock to produce a syngas stream comprising carbon dioxide, hydrogen, and carbon monoxide;  
reforming the syngas stream to produce a hydrogen-enriched syngas stream;  
separating carbon dioxide from the hydrogen-enriched syngas stream in a separation unit to produce a carbon dioxide stream and a purified syngas stream having a hydrogen to carbon monoxide ratio of at least 1.5:1;  
enriching the purified syngas with additional hydrogen;  
reacting the purified syngas stream and hydrogen enriched syngas stream, in a Fischer Tropsch reactor to produce Fischer-Tropsch liquids, water, and tail gas;  
recycling a portion of the water from the Fischer Tropsch reactor to an electrolysis unit, and  
electrolyzing the water in the electrolysis unit to produce an oxygen stream and a hydrogen stream.
15. The process of claim 14, further comprising purifying the carbon dioxide stream generated from the separation unit to produce a purified carbon dioxide stream, recycling the purified carbon dioxide stream to the reforming step.
16. The process of claim 14, further comprising recycling a portion of the oxygen stream and a portion of the hydrogen stream to the gasification step, the reforming step, or combinations thereof.
17. The process of claim 15, further comprising: recycling a portion of the hydrogen stream and a portion of the purified carbon dioxide stream to a reverse water-gas-shift reactor to produce carbon monoxide.



18. The process of claim 14, further comprising processing natural gas in a reforming unit to produce a second syngas stream that is supplied to the Fischer Tropsch reactor.
19. The process of claim 14, wherein the electrolysis unit is powered by solar energy, wind energy, hydroelectric energy, nuclear energy, or tidal energy.
20. The process of claim 14, further comprising treating the water from the Fischer Tropsch reactor to produce purified water, wherein the purified water is electrolyzed in the electrolysis unit.

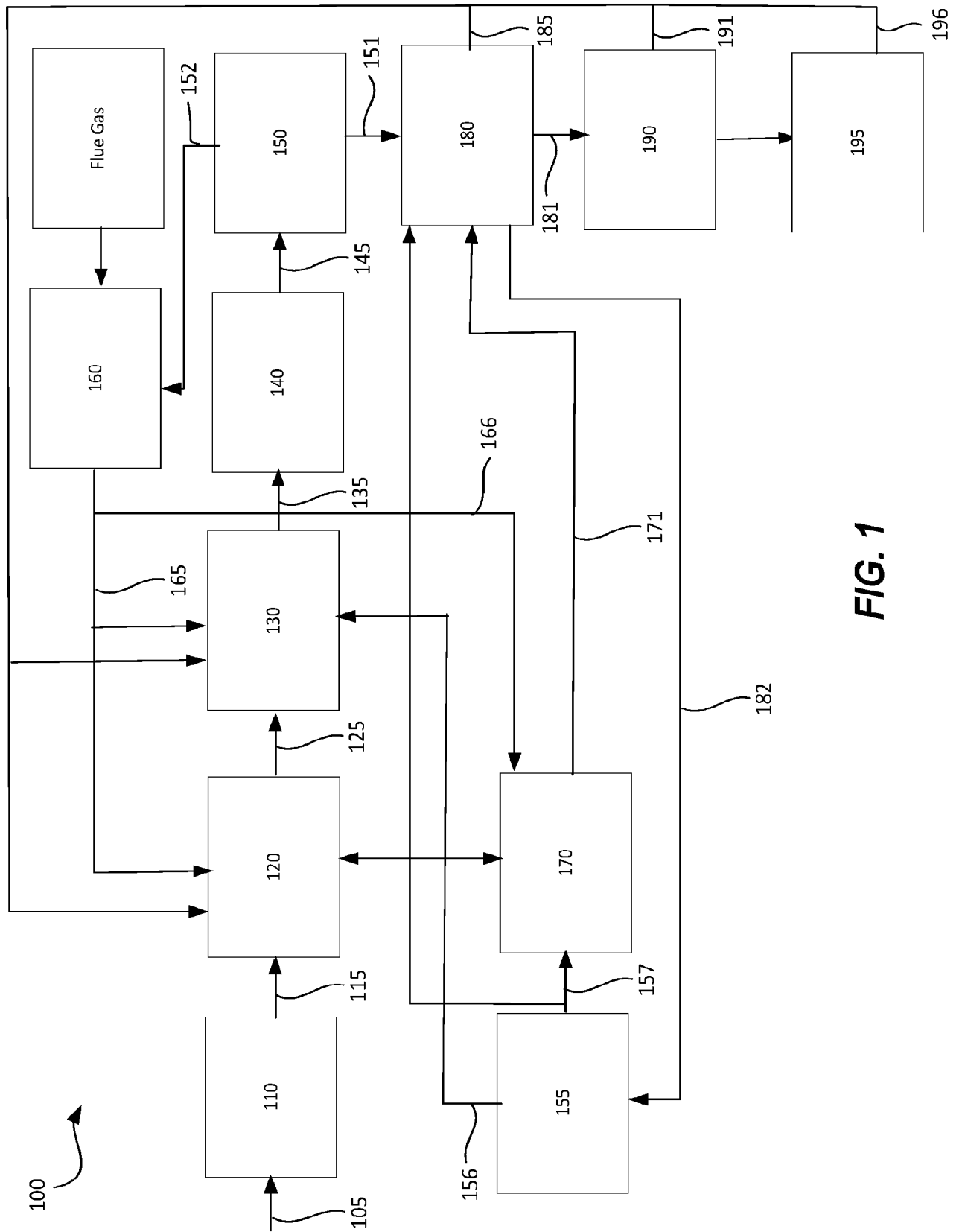

FIG. 1

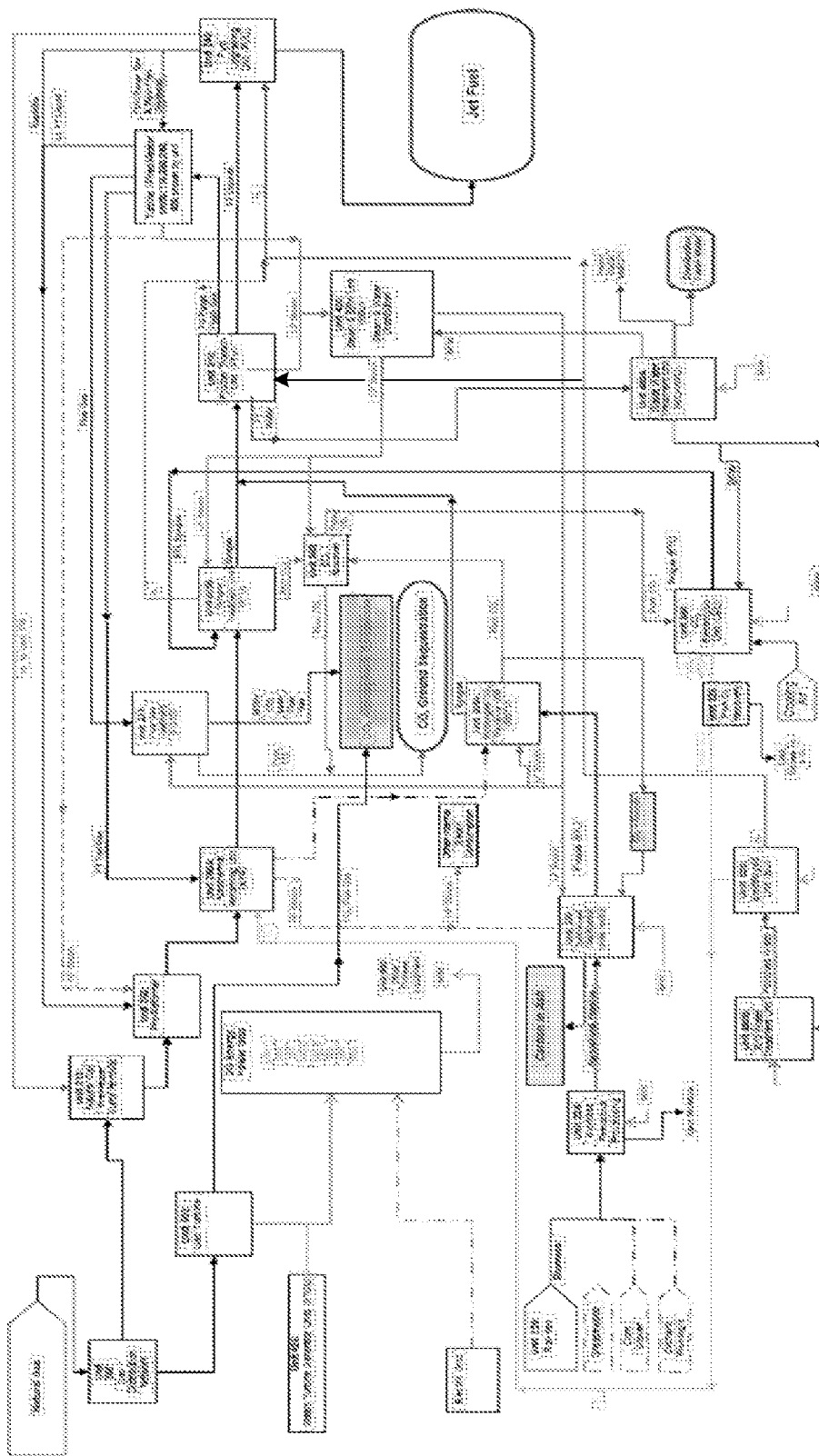
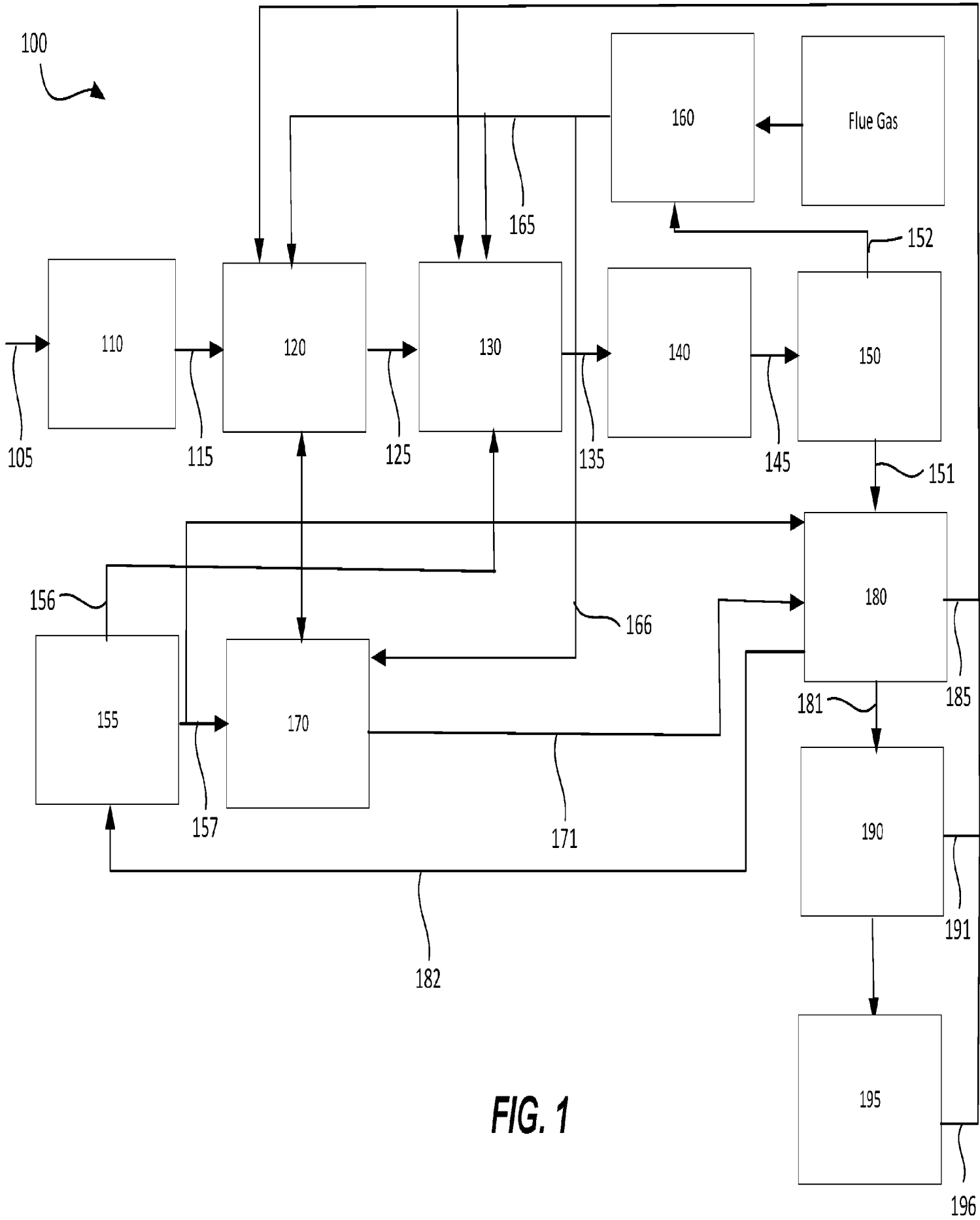

FIG. 2



**FIG. 1**