

March 11, 1969

S. BETSO

3,431,591

SELECTIVELY RELEASABLE ENGAGEABLE SEPARABLE-LEAF HINGE

Filed June 8, 1967

Sheet 1 of 2

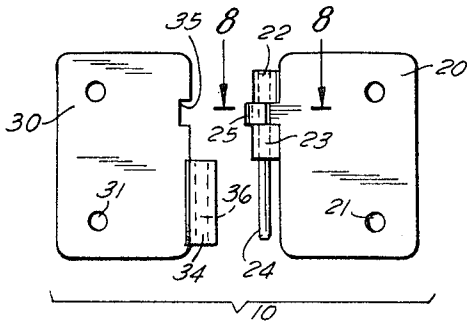

FIG. 1

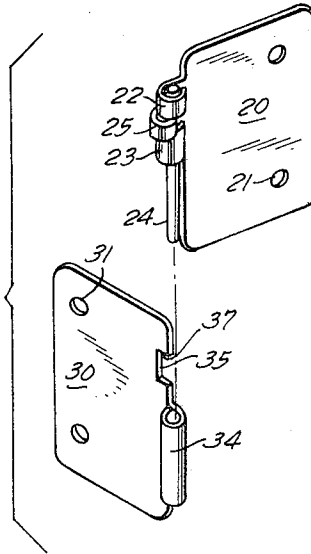

FIG. 2

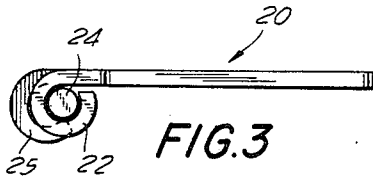

FIG. 3

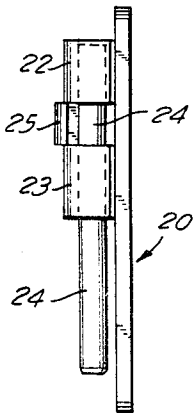

FIG. 4

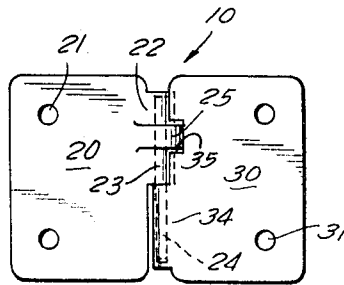

FIG. 5

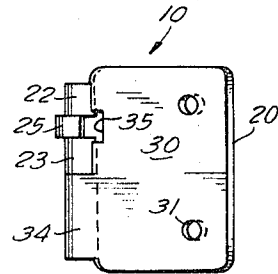

FIG. 6

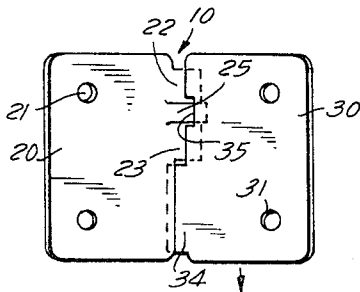

FIG. 7

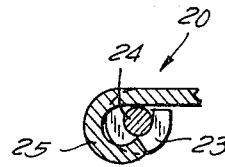

FIG. 8

INVENTOR
STEPHEN BETSO

BY *A. A. Orlinger*
ATTORNEY

March 11, 1969

S. BETSO

3,431,591

SELECTIVELY RELEASABLE ENGAGEABLE SEPARABLE-LEAF HINGE

Filed June 5, 1967

Sheet 2 of 3

FIG. 9

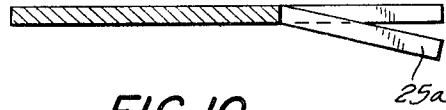
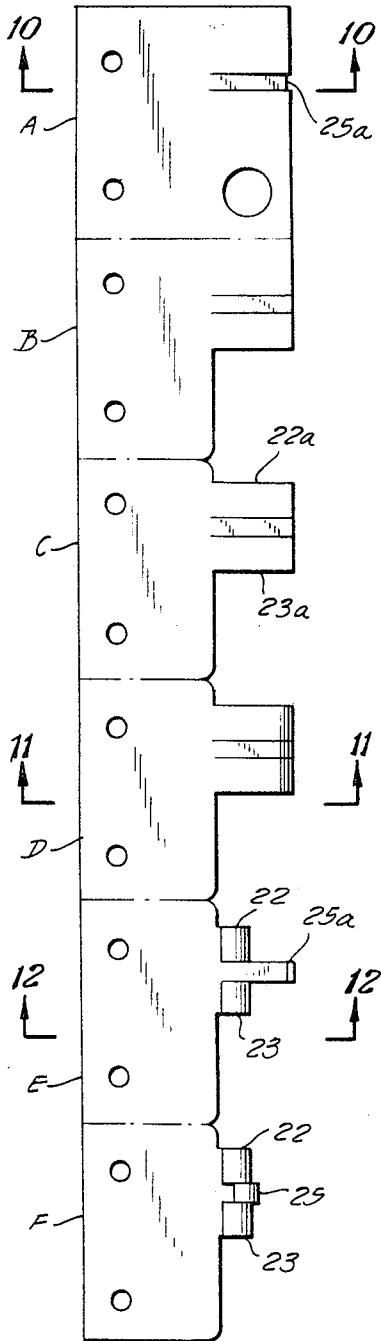

FIG. 10



FIG. 11

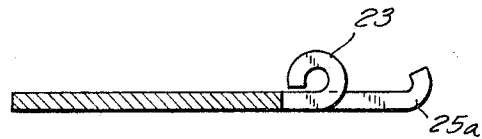

FIG. 12

INVENTOR
STEPHEN BETSO
BY *J. A. Orlinger*
ATTORNEY

1

2

3,431,591

**SELECTIVELY RELEASABLE ENGAGEABLE
SEPARABLE-LEAF HINGE**

Stephen Betso, Brooklyn, N.Y., assignor to A. Ludwig & Co., Inc., New York, N.Y., a corporation of New York

Filed June 5, 1967, Ser. No. 643,607
U.S. Cl. 16—171
Int. Cl. E05d 7/10

8 Claims

ABSTRACT OF THE DISCLOSURE

The invention is a separable hinge unit having a pair of hinge leaves one having along its hingeably engaging side a sleeve having an engaging pintle rigidly affixed in it and with its part usually exposed to be swingably in a pintle-bearing on the other leaf, and selectively operable locking means which enable having the leaves in locked inter-engaged relation for use of the closure.

This invention is that of a selectively releasable engageable separable-leaf hinge (or hinge unit) suitable, for example, for use in mounting doors or other swingable closures on various articles of furniture such as cabinets or other compartments or structures needing closing with selectively separable hinged closures. The particular separable-leaf hinge of the invention allows a pivotally attached door or other closure to be mounted or disengaged and removed at one's option at at least one predetermined angular position of the closure relative to the opening to be closed by it.

More specifically, the invention is that of a separable-leaf hinge (or hinge unit) having (a) a pair of ordinary hinge leaves one of which has along what is its ordinarily hingeably engaging side a sleeve having (b) a joining or engaging pintle rigidly affixed in it and with the usual part of it exposed to be swingably mounted in a pintle-bearing on the other leaf, and (c) selectively operable locking means which allow one at his option to have the leaves in locked inter-engaged relation to use the closure or alternatively to disengage the leaves to permit removing the closure. The locking means includes an arcuate securing segment associated with either the pintle-bearing sleeve or the pintle-receiving-bearing of one of the leaves and positioned opposite to, so as to act in registry with, a segment-engaging notch in a sleeveless portion of the hingeably engaging side of the second leaf.

Separable-leaf hinges described before this invention allow a part attached to one of the hinge leaves to be removed, for example, when the leaves are in one or another different relative angular positions. However, some of these earlier hinges or hinge units are impracticably complicated in that they require costly, exactly machined or shaped knuckles, shoulders or various inter-engaging elements. Others are unreliable in their operation, resulting in undesirable blocking of the attached structural parts when they are to be disengaged for removal from the other parts. Still others have limitedly effective unusual structures which require leaf outlines considerably different from the substantially rectangular or triangular ordinary hinge-leaf shapes with a pintle-encircling sleeve along part of the usual hingeably engaging side of one leaf and a pintle bearing in the other.

The restrictions, limitations and drawbacks of the earlier separable-leaf hinges are overcome and avoided by the separable-leaf hinge of this invention, a highly significant feature of which latter hinge is that it has exactly the same overall outline as that of an ordinary hinge of no special construction.

Another feature of the hinge of the invention is that it

very readily enables disengaging the leaves for removing a door or other closure and replacing them when desired, and all without experiencing any difficulty in operation, for example, when the closure is positioned to locate the hinge leaves in substantially parallel face to face superposed position.

Yet another feature of the hinge of the invention is that it can be produced by the usual automatic equipment used in making an ordinary two leaf hinge, with no extensive changes in tooling and at relatively little more cost other than for the tooling changes.

Still another feature of the hinge of the invention is that its separable-leaf hinge similarly can be provided with slight modification in its arcuate securing segment to enable engaging the leaves when they are at more than one relative position including open extended relative position of the leaves.

Considered broadly, the selectively inseparable and engageable and then disengageable separable-leaf hinge of the invention includes (a) a pair of selectively hingeably engageable and disengageable hinge leaves, each one having a pintle-encircling sleeve along part of its hingeably engaging side (i.e. the side nearer the other leaf when both are hingeably engaged), one of the sleeves being the pintle-receiving-bearing sleeve and the other the pintle-carrying sleeve, each sleeve being integral with its respective leaf and offset along its hinged side from its midpoint in the direction opposite that in which the other sleeve is offset from its hinged side midpoint of its leaf (whereby the outer end of each sleeve is nearer the oppositely spaced away side end of its respective leaf) so that both sleeves then appear like a continuous cylinder between the opposed hinged sides of both leaves when they are hingeably engaged; (b) a pintle held in part fixedly anchored in the bore of the pintle-carrying sleeve and having its protruding remaining engaging part extending parallel to and spaced from the hinged side of its leaf sufficient to fit far enough into the bore of the bearing sleeve to enable adequately hingeably engaging both leaves; and (c) hingeably-lockably selectively engageable and disengageable locking means having (i) a locking notch in the sleeveless part of the hinged side of one leaf, and (ii) an arcuate notch-engaging segment integrally extending from the opposing sleeve-bearing part of the hinged side of the second leaf and located opposite to where the notch would appear in the first leaf (when both are hingeably engaged) so as to enable being placed in register with the notch and with the outer peripheral surface of the segment for at least part of its arcuate length protruding radially outwardly past the corresponding or neighboring part of the outer peripheral surface of its associated sleeve.

The length, and extent of protrusion, of the protruding part of this segment is sufficient, based on the thickness of the leaf and this segment (e.g. one-sixteenth or three-thirty-seconds of an inch), to enable the outer side wall to miss that protruding part of the arcuate segment when the leaves are in at least one angular position relative to one another, and thereby to enable inserting the pintle into the bore of the bearing sleeve to inter-engage the leaves. Then, adjusting the leaves to another relative angular position results in moving the protruding part of the arcuate segment between both side walls of the engaging notch thereby to lock the leaves into inseparable engagement.

The notch-engaging arcuate segment can be formed of such shape and length to enable the leaves to be engaged or disengaged selectively in either a single relative angular position or for more flexible utility in at least one other relative angular position as more fully described in the later detailed description.

Other features of the hinge of the invention can be

seen from the later detailed description of the illustrative, but not to be taken as limiting, embodiment of the invention shown in the accompanying drawing, wherein—

FIG. 1 is a plan view of the two separated hinge leaves constituting a hinge unit for the hinge of this invention;

FIG. 2 is an exploded isomeric view of the separated leaves of the hinge unit of FIG. 1 shown in a different relative angular position and above one another;

FIG. 3 is an enlarged top view of the hinge leaf having the pintle-carrying sleeve and associated with it an arcuate securing segment as a projection with an eccentric portion extending similarly from the same part of the one side of the leaf;

FIG. 4 is an enlarged end view of the hinge leaf shown in FIG. 3;

FIG. 5 is a rear plan view of the hinge with its leaves inter-locked and extending away from one another and in the same plane;

FIG. 6 is a front view of the hinge of FIG. 5 with its leaves inter-engaged and closed in superposed face to face relation; the arrow indicating that the leaves can be disengaged by moving the front leaf downward relative to the rear leaf remaining stationary;

FIG. 7 is a view similar to that of FIG. 5 but showing the leaves from the rear in a position past their fully extended position (i.e. rotated more than 180 degrees from their FIG. 5 relationship); and

FIG. 8 is a fragmentary sectional view of the hinge leaf shown in FIGS. 3 and 4, taken along line 8—8 of FIG. 1 and viewed in the direction of the arrows;

FIG. 9 is a plan view of a strip of steel showing the changes successively made in it in six consecutive steps in producing a hinge leaf with a divided sleeve including an arcuate notch-engaging segment;

FIG. 10 is a cross-section along line 10—10 of FIG. 9 looking in the direction of the arrow, to show the initial cutting of the strip or segment which later is to become the arcuate notch-engaging segment;

FIG. 11 is a cross-section along the line 11—11 of FIG. 9, showing the two separated parts to be formed into a sleeve with the strip for the arcuate segment between them, all jointly given a preliminary turn or bend; and

FIG. 12 is another such section along line 12—12 of FIG. 9, showing the two separated parts of the sleeve in finished turned form with the intermediate strip still to be further formed into the arcuate segment.

Referring to the drawing, and initially primarily to FIG. 1, the complete hinge unit 10 includes its separate hinge leaves 20 and 30. The planar surfaces of these leaves are adapted to be attached, for example, to a door and its frame (not shown) in conventional manner, e.g. by screws or other attaching means driven through apertures or holes 21, 31 to affix the respective leaves of the hinge to the door and its frame, i.e. of a cabinet (or other piece of furniture or other article) on which the hinge unit is to be used. Hinge leaf 20 in this case preferably is secured to the door which is to be pivotably removably mounted on the cabinet, while leaf 30 then is attached to the frame and so is to remain stationary.

Offset upwardly (as seen in FIGS. 1, 2 and 4-7) from the midpoint of the hingeably engaging side of leaf 20 (that is, its side which would be nearest leaf 30 when both leaves are hingeably inter-engaged) is the pintle-carrying sleeve, in this embodiment advantageously consisting of its two axially spaced apart sleeve-parts 22 and 23. Pintle 24 is fixedly fittedly secured within the co-axially aligned bores of sleeve parts 22 and 23, with its lower or hingeably engaging protruding portion extending downwardly spaced away from the lower and so-called sleeveless part of the hingeably engaging side of leaf 20.

Advantageously, arcuate notch-engaging finger or segment 25 projects outwardly from hinge leaf 20 intermediate its pintle-holding sleeve-parts 22 and 23 and formed outwardly eccentric with respect to them and pintle 24.

Pintle-bearing 34 with its open-ended longitudinal bore 36 extends outwardly from hinge leaf 30, for receiving pintle 24 when leaves 20 and 30 are inter-engaged by a sliding movement parallel to their adjacently opposite edges to insert the free end of pintle 24 into bore 36.

The selectively engageable and disengageable locking means for the separable-leaf hinge of the invention includes the arcuate notch-engaging segment 25 and the arcuate segment-engaging recess or notch 35 beneficially rectangular to conform to the cross-section of segment 25 normal to its length and advantageously only sufficiently larger than that cross-section to avoid undesirable play when the segment 25 is engaged in the notch 35. The latter is spaced apart from pintle-bearing 34 longitudinally along the sleeveless part of that side of leaf 30 so as to be able to receive arcuate segment 25 of leaf 20 when the leaves are in certain relative angular positions wherein segment 25 does not prevent proper or full reception of pintle 24 in bore 36 of bearing 34.

For example, when one attempts to slide hinge leaf 20 from above downwardly into hingeable engagement with leaf 30 by inserting pintle 24 into the open upper end of bearing 34, the relative horizontal angular position of leaf 20 to leaf 30 by presenting the corresponding relative position between arcuate segment 25 and the upper peripheral parts of leaf 30 will determine whether the leaves can be hingeably engaged or not. When the protruding part of segment 25 abuts against those upper peripheral portions (as along the upper edge of leaf 30 and near the upper end of notch 35, pintle 24 cannot be fully and properly inserted into bore 36 of bearing 34.

Leaf 20 then should be rotated sufficiently respective to the (ordinarily stationary) leaf 30 until (a) the outer or free end of arcuate segment 25 misses the flat surface of leaf 30 whereby that upper edge of its hingeable side can pass through the gap between the outer end of segment 25 and the planar surface of leaf 30, or alternatively (b) the inner arcuate end of segment 25 (where there is no or insignificantly little protrusion of it) faces the upper peripheral portion of leaf 30, whereby segment 25 misses notch 35, so that the protruding part of pintle 24 can be fully inserted into the bore of bearing 34.

Then, with the free part of pintle 24 fully and properly inserted in bearing 34, the fully available pivotal or hinge movement between both leaves is possible, and they cannot be disengaged so long as segment 25 protrudes into notch 35 sufficiently to contact its upper wall 37.

To disengage leaf 20 or any door on which it is mounted from leaf 30 (which may be mounted on a frame of, for example, a cabinet), the door should be swung to rotate leaf 20 to a position where (a) the gap between the outer end of segment 25 and the flat plane of leaf 20, or (b) the inner insufficiently protruding or anchoring end of segment 25 will not touch the upper edge 37 of notch 35, enables segment 25 to clear the recess to enable leaf 20 to be raised along that inner hingeable edge of leaf 30 until pintle 24 is withdrawn fully from bore 36 and is free of bearing 34.

Thus, the curvature of segment 25 advantageously is such that (a) its outer end falls short of making it a complete circle and so enables inter-engagement or separation of the leaves when they are in a face to face substantially parallel position, e.g. as shown in FIG. 6, or (b) alternatively the protrusion of segment 25 is from insignificantly small to none at all so as to miss upper wall 37 of notch 35 when the leaves are in openly extended aligned relationship at from about 180 to about 210 degrees to one another (e.g., as seen in FIG. 7). That gives the maker of the cabinet or other articles of furniture more than one choice as to how to set up the door relative to the frame or opening to be closed by the doors and how to set up the hinged leaves to permit removing the door when the hinge leaves are in a desired one of the available positions.

Arcuate segments 25 need not be confined to its present-

ly apparently more effective location between sleeve parts 22 and 23 as shown in the drawings. It may be located elsewhere in either direction along the pintle-carrying sleeve, or at an end of it (so that the rest of the pintle-carrying sleeve constitutes a single part), so long as recess or notch 35 correspondingly is relocated along the sleeveless part of the hinge-engageable side of leaf 30.

Alternatively, arcuate notch-engaging segment 25 can be omitted from the pintle-carrying sleeve and instead similarly be made a part of pintle-bearing 34. In that case recess or notch 35 will need to be made in a corresponding location along the sleeveless part of the hinge-engaging side of leaf 20 to be able to be opposite segment 25 for the latter to be able to be engaged in registry with the notch 35. While none of these alternate variations is shown in the drawings, each of them readily is understandable to a person of ordinary skill in the art from the detailed description of the illustrated embodiment.

Whichever of leaves 20 or 30 is to be the one having a sleeve with an arcuate notch-engaging segment associated with it, the production of that particular leaf is explained best in relation to FIGS. 9 through 12. The broken lines in FIG. 9 divide the metal (e.g. steel) strip from which the particular leaf is to be made into six different sections each identified by a different one of the letters A through F and showing the successive state of an individual strip section for a leaf as it progresses through six consecutive steps in its production.

In each stage the small circles represent the holes for receiving the screws to attach the finished leaf to the article onto which it is to be used. The large circle represents merely a so-called locating hole as used to assist in properly setting the strip in relation to the particular operating die which is to work on the step at the specific operating stage.

Stage A shows the cutout 2-sided section resulting after a double-edged lancing tool lanced the metal strip to provide piece 25a which is to become the arcuate segment 25, and leaving it bent out of the plane of the entire strip (as shown in FIG. 10). At the next stage B, piece 25a has been straightened back into the plane of the metal strip and unnecessary metal was cut away to provide the so-called sleeveless part of the hingeably engageable side of the leaf being produced and another portion 23a which is to be formed into sleeve-part 23.

At stage C, removal of the excess metal leaves another portion 22a which is to become the sleeve-part 22. In stage D an end-turning die gave the outer ends of the three portions 22a, 25a and 23a a preliminary bend. Then at stage E the portions 22a and 23a were bent further by spaced apart dual turning dies to complete the circular bend and provide the sleeve-parts 22 and 23 (as further shown in FIG. 12).

Finally, in stage F a die having a slightly larger radius than that used in stage E similarly converted the remaining portion 25a into the final form of arcuate notch-engaging segment 25. Thereafter, the finished leaf is cut off with or without having its left hand corners rounded.

If no pintle is inserted in the sleeve-parts 22 and 23 obtained from stage F, then the leaf obtained can serve as a right hand pintle-bearing leaf with an associated arcuate notch-engaging segment. Otherwise, forcefully fitting a pintle pin into sleeve-parts 22 and 23 of the finished leaf makes it a so-called left hand pintle-carrying leaf if leaf 20 of FIG. 1 is called a right hand pintle-carrying leaf.

From the foregoing production description, a person of ordinary skill in the art would know how to produce a right hand pintle-carrying leaf. Such person of ordinary skill in the art then also would know that by omitting the lancing operation of stage A and changing the outline of the die for cutting away the excess metal at stage B to one that also can cut out a notch along the sleeveless part of the hingeably engageable edge, there similarly is

produced a leaf with a pintle-receiving-bearing and an arcuate segment-engaging notch.

What is claimed is:

1. A selectively inseparably engageable and disengageable separable-leaf hinge comprising

(a) a pair of selectively hingeably engageable and disengageable hinge leaves, each leaf having along part of what is its hingeably engaging side a pintle-encircling sleeve, one of said sleeves being the pintle-receiving-bearing sleeve, and the other sleeve being the pintle-carrying sleeve, each said sleeve being an integral part of its respective hinge leaf and located offset along said hinged side from its midpoint in the opposite direction from which the other sleeve is offset so that the outer end of the sleeve is near a side end of the leaf and both sleeves appear like a continuous cylinder between the opposed hinged sides of the two leaves when they are hingeably engaged;

(b) a pintle with its anchored part fixedly held within the bore of the pintle-carrying sleeve and its engaging end spaced away from and extending parallel to the hinged side of its respective leaf a distance sufficient to enable it to extend into the bore of the pintle-receiving-bearing sleeve to provide adequately hingeable engagement of both leaves; and

(c) hingeably-lockably engageable and otherwise disengageable locking means including (i) a notch in the sleeveless part of the hinged side of one of the leaves, and (ii) integrally extending from the opposing sleeve-bearing part of the hinge side of the second leaf, and opposite to so as to be able to be placed in registry with said notch in the first leaf, an arcuate notch-engaging segment whose outer peripheral surface for at least part of its arcuate length protrudes radially outwardly beyond the corresponding part of the outer peripheral surface of its associated sleeve on said second leaf, the length of said part of the arcuate segment protruding outwardly beyond the outer peripheral surface of the associated sleeve being sufficient to let the outer side wall of said notch miss said protruding part of the arcuate segment in at least one relative angular position of the leaves and thereby enable inserting the pintle into the bore of said pintle-receiving-bearing sleeve to interengage the leaves whereby changing the leaves to another relative angular position moves the protruding part of the arcuate segment between the side walls of the notch to lock the leaves into inseparable engagement.

2. The hinge as defined in claim 1, wherein the pintle pin can be inserted into said pintle-receiving-bearing sleeve to bring the leaves into engagement and the leaves can be disengaged only when they are in a single relative angular position.

3. The hinge as defined in claim 1, wherein the pintle pin can be inserted into said pintle-receiving-bearing sleeve to bring the leaves into engagement and the leaves can be disengaged when they are in any of a plurality of relative angular positions.

4. The hinge as defined in claim 1, wherein the sleeve in said second leaf is divided into two axially separated parts and the arcuate segment is intermediate said separated sleeve parts.

5. The hinge as defined in claim 4, wherein the pintle extends through said separated sleeve parts and the arcuate segment between them and is held in friction tight engagement within the bore of said sleeve parts.

6. The hinge as defined in claim 1, wherein each of said sleeves is offset from its respective leaf in such direction that when the hinge has its leaves in their engaged relationship and extending from one another in about 180 degree alignment, the hinge can be laid flat on a flat surface with the leaves in the said alignment and the sleeves then appear like a substantially unitary cylinder with the lowest element of its peripheral surface

7

substantially lying on and touching said flat surface and with its axis parallel to and spaced upwardly from the plane passing through the upwardly facing surfaces of the leaves.

7. The hinge unit is defined in claim 6, wherein the outer end of the radially outwardly protruding part of the arcuate segment terminates at a position to miss the outer wall of the notch when the hinge leaves are in a relative angular position of being face to face and about parallel to one another.

8. The hinge unit as defined in claim 7, wherein the hinge leaves can be brought into engagement and also

8

disengaged only when they are in the relative angular position of being face to face and substantially parallel to one another.

References Cited

UNITED STATES PATENTS

1,962,709	6/1934	Case	-----	16-171
2,683,892	1/1954	Gorman	-----	16-176

BOBBY R. GAY, *Primary Examiner*.

D. L. TROUTMAN, *Assistant Examiner*.