



US 20090154091A1

(19) **United States**
(12) **Patent Application Publication**
Yatskov

(10) **Pub. No.: US 2009/0154091 A1**
(43) **Pub. Date: Jun. 18, 2009**

(54) **COOLING SYSTEMS AND HEAT EXCHANGERS FOR COOLING COMPUTER COMPONENTS**

Publication Classification

(51) **Int. Cl.**
H05K 7/20 (2006.01)
F28D 15/00 (2006.01)
(52) **U.S. Cl.** **361/679.49; 165/104.33**
(57) **ABSTRACT**

(76) **Inventor: Alexander I. Yatskov, Kenmore, WA (US)**

Correspondence Address:
PERKINS COIE LLP
PATENT-SEA
P.O. BOX 1247
SEATTLE, WA 98111-1247 (US)

Computer systems having heat exchangers for cooling computer components are disclosed herein. The computer systems include a computer cabinet having an air inlet, an air outlet spaced apart from the air inlet, and a plurality of computer module compartments positioned between the air inlet and the air outlet. The air inlet, the air outlet, and the computer module compartments define an air flow path through the computer cabinet. The computer systems also include a heat exchanger positioned between two adjacent computer module compartments. The heat exchanger includes a plurality of heat exchange elements canted relative to the air flow path.

(21) **Appl. No.: 11/958,114**

(22) **Filed: Dec. 17, 2007**

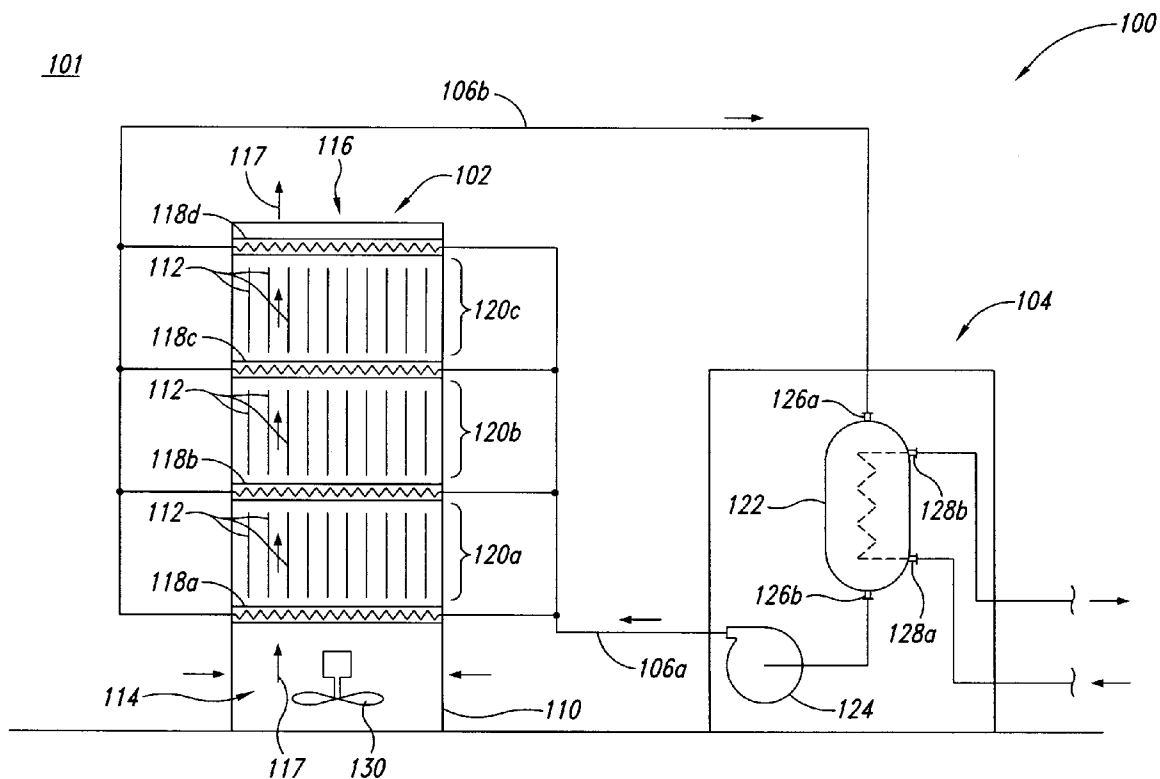

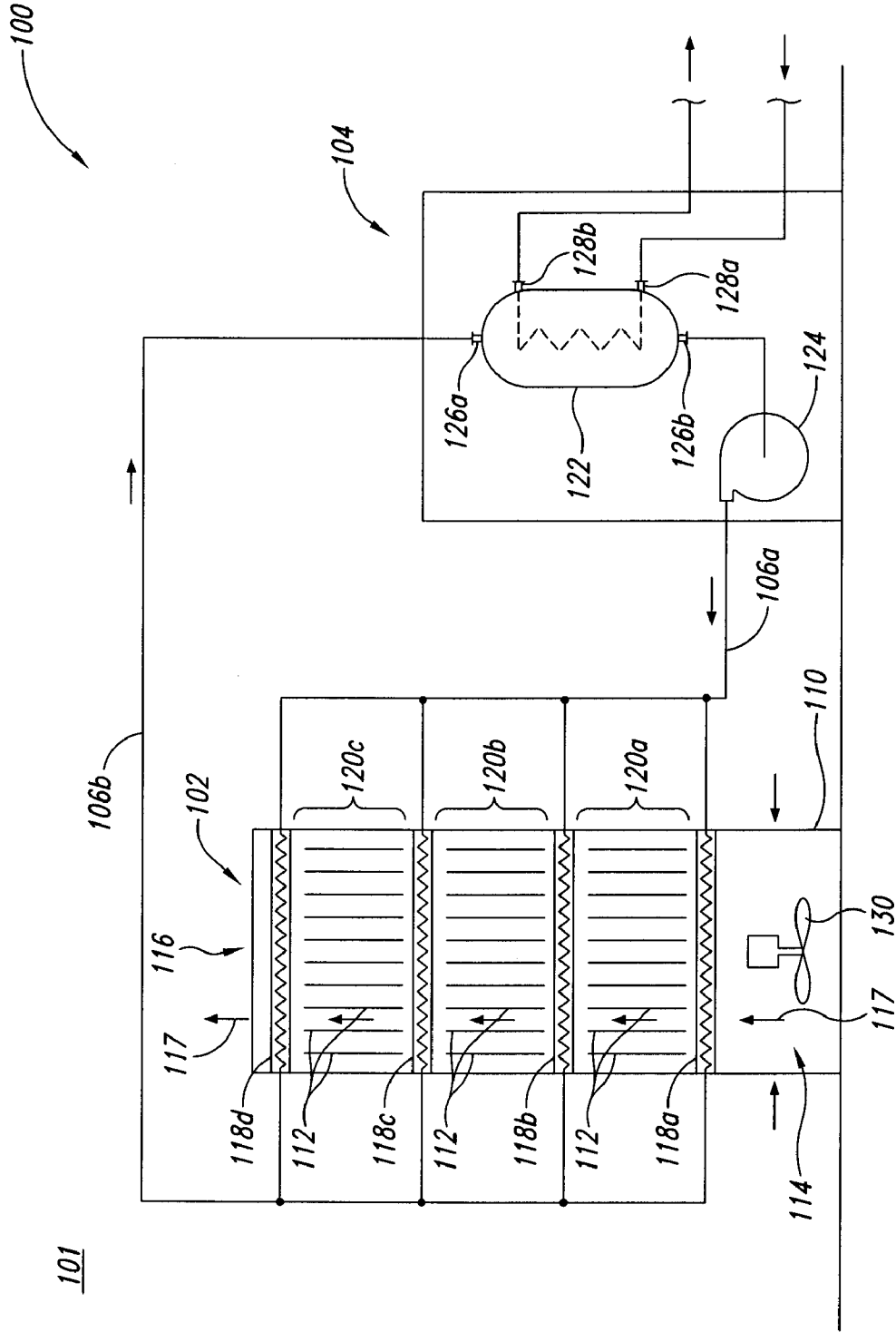

Fig. 1A

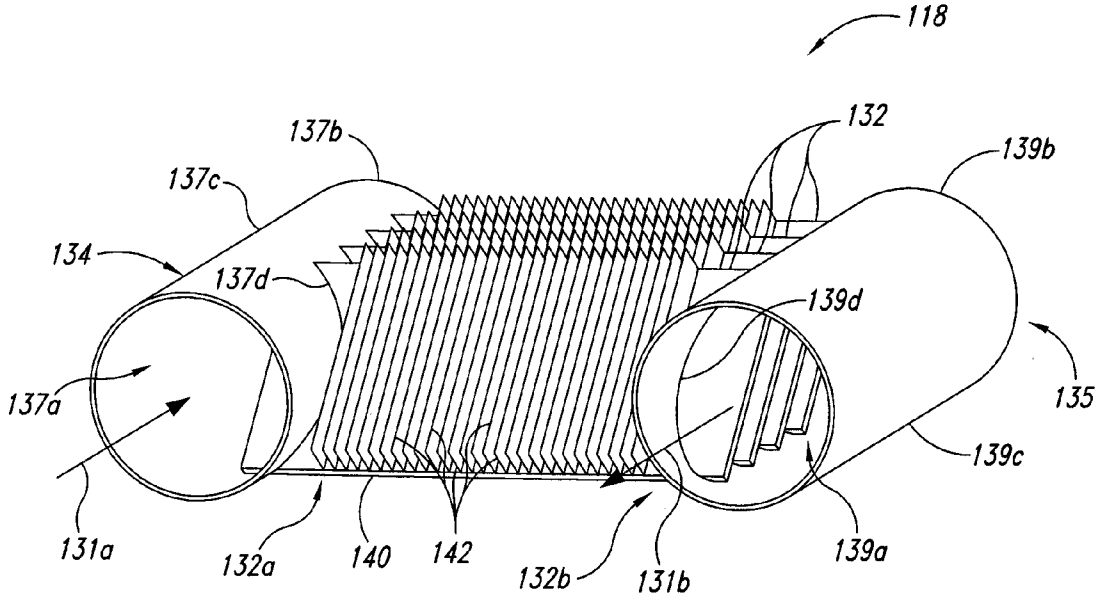

Fig. 1B

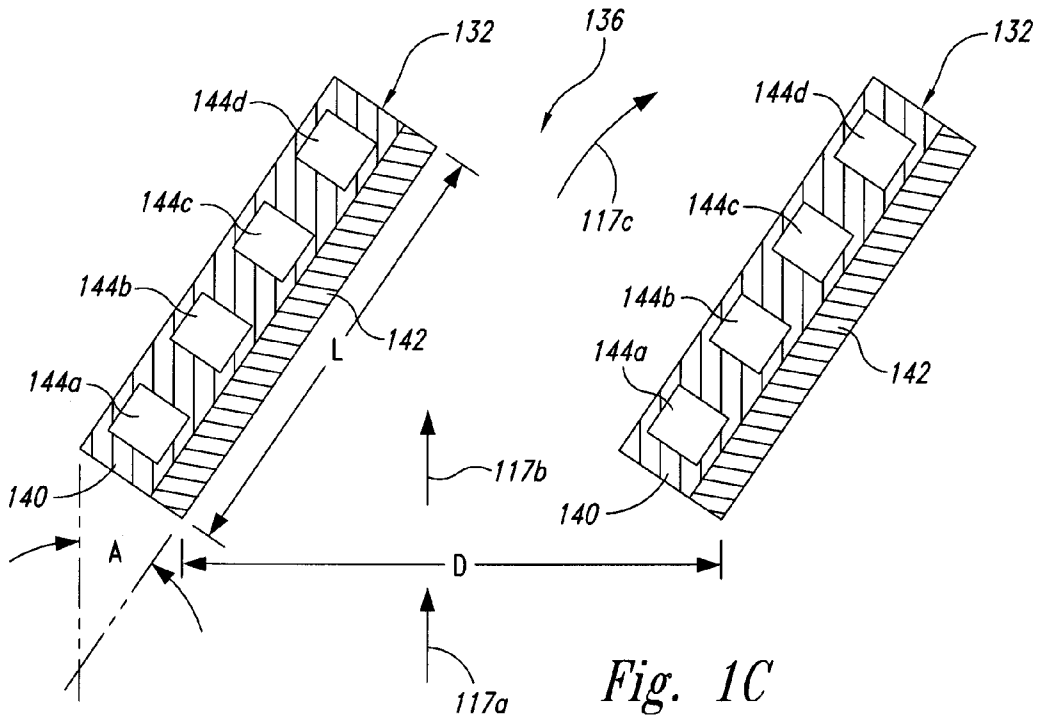

Fig. 1C

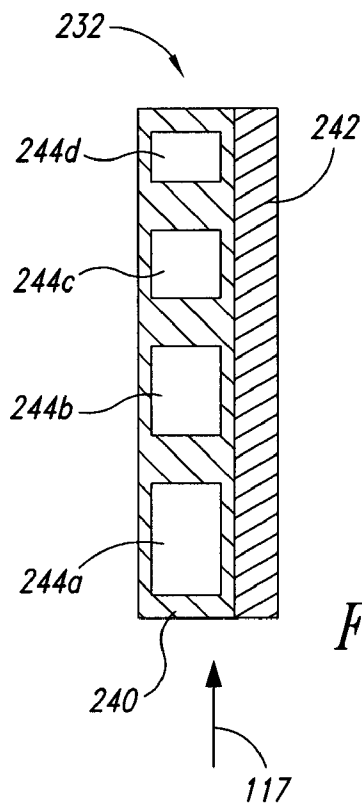

Fig. 2

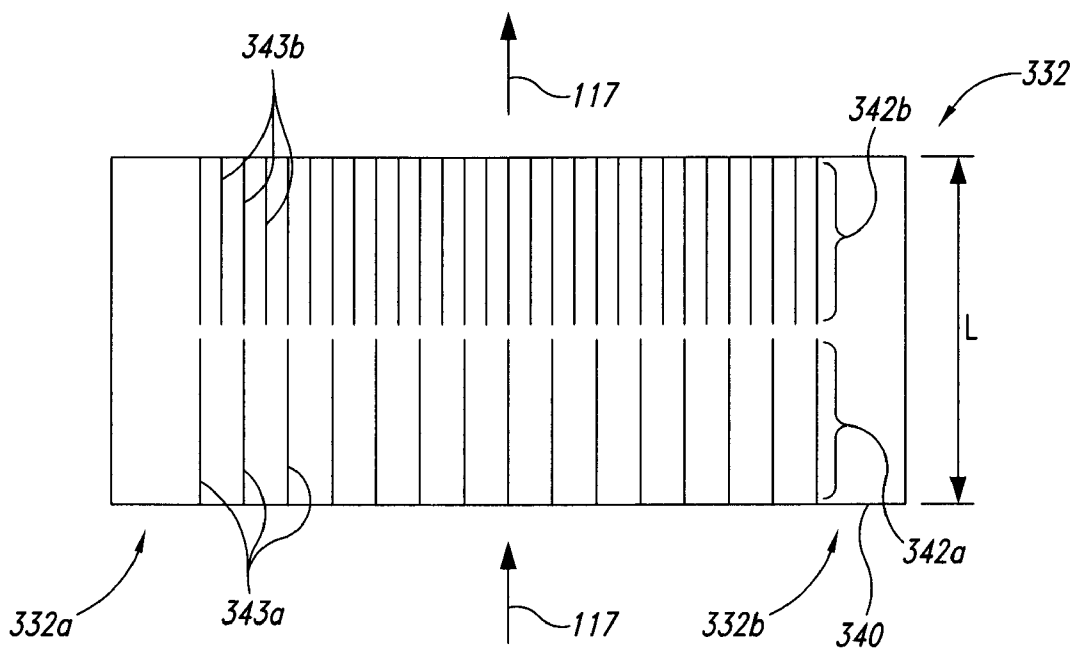

Fig. 3

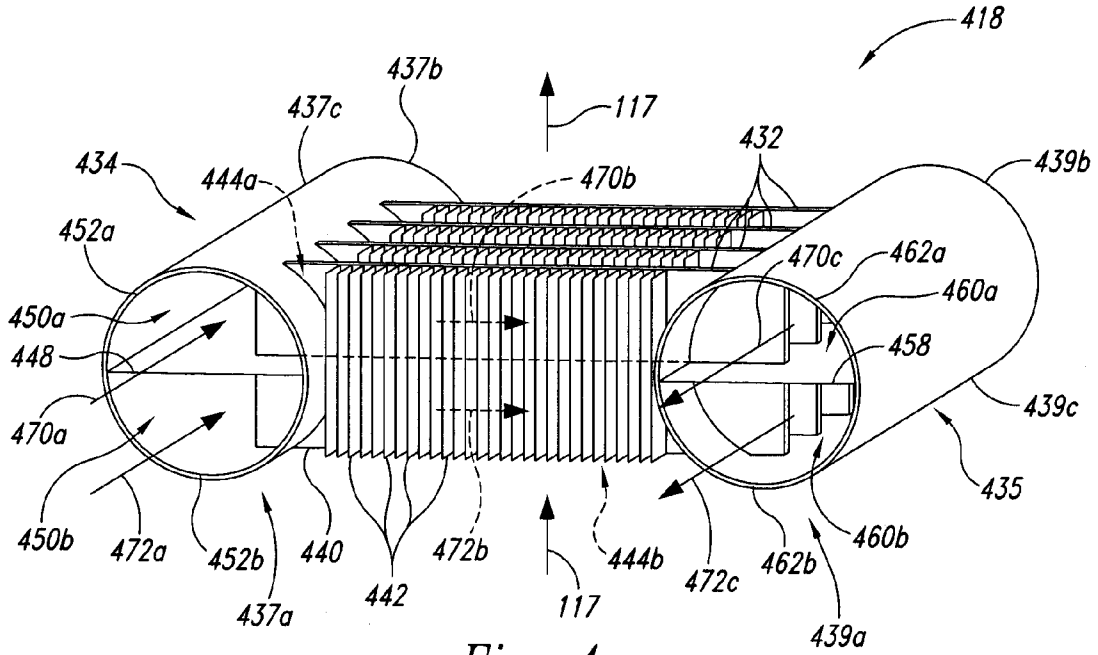

Fig. 4

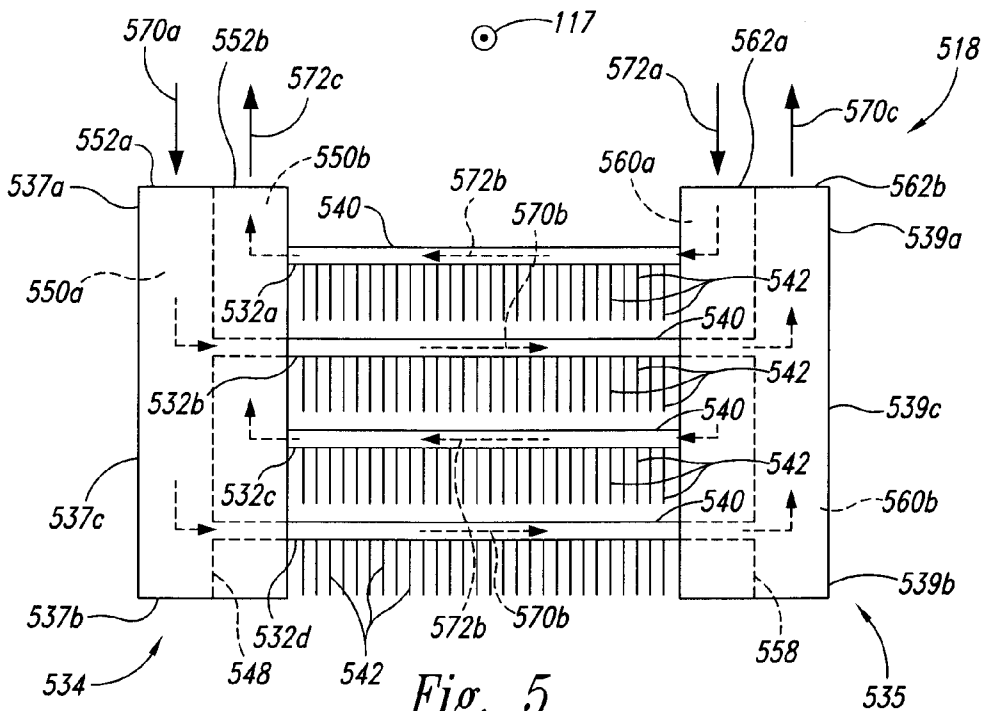

Fig. 5

**COOLING SYSTEMS AND HEAT
EXCHANGERS FOR COOLING COMPUTER
COMPONENTS**

TECHNICAL FIELD

[0001] The present disclosure relates generally to cooling systems and heat exchangers for cooling electronic components in computer systems.

BACKGROUND

[0002] Supercomputers and other large computer systems typically include a large number of computer modules housed in cabinets arranged in banks. The computer modules are typically positioned in close proximity to each other. During operation, the close proximity can make dissipating heat generated by the modules difficult. If not dissipated, the heat can damage the modules or significantly reduce system performance.

[0003] One conventional technique for computer module cooling includes drawing air into the cabinet to cool the computer modules and discharging the heated air to the room. One shortcoming of this technique, however, is that the heat capacity of the cooling air can quickly become saturated. As a result, some of the computer modules may not be adequately cooled. Accordingly, there is a need to effectively dissipate heat generated by computer modules during operation.

BRIEF DESCRIPTION OF THE DRAWINGS

[0004] FIG. 1A is a partially schematic elevation view of a computer system having internal heat exchangers configured in accordance with an embodiment of the invention.

[0005] FIG. 1B is an enlarged perspective view of a heat exchanger having canted heat exchange elements configured in accordance with an embodiment of the invention.

[0006] FIG. 1C is an enlarged, cross-sectional side view of two heat exchange elements from the heat exchanger of FIG. 1B, configured in accordance with an embodiment of the invention.

[0007] FIG. 2 is a cross-sectional side view of a heat exchange element having non-identical internal channels configured in accordance with another embodiment of the invention.

[0008] FIG. 3 is a front view of a heat exchange element having a plurality of fin configurations positioned along an air flow path in accordance with another embodiment of the invention.

[0009] FIG. 4 is a perspective view of a heat exchanger having partitioned inlet and/or outlet manifolds configured in accordance with another embodiment of the invention and suitable for use in the computer system of FIG. 1A.

[0010] FIG. 5 is a top view of a heat exchanger having counter-flowing working fluids configured in accordance with a further embodiment of the invention and suitable for use in the computer system of FIG. 1A.

DETAILED DESCRIPTION

[0011] The following disclosure describes several embodiments of cooling systems for use with supercomputers and/or other computer systems. Persons of ordinary skill in the art will understand, however, that the invention can have other embodiments with additional features, or without several of the features shown and described below with reference to

FIGS. 1-5. In the Figures, identical reference numbers identify structurally and/or functionally identical, or at least generally similar, elements.

[0012] FIG. 1A is a partially schematic elevation view of a computer system 100 having a plurality of internal heat exchangers 118 (identified individually as heat exchangers 118a-d) configured in accordance with an embodiment of the invention. The computer system 100 can include a computer cabinet 102 in a room 101. Working fluid lines 106 (identified individually as a supply line 106a and a return line 106b) connect the computer cabinet 102 to a heat removal system 104. In the illustrated embodiment, the heat removal system 104 is situated in the room 101 and spaced apart from the computer cabinet 102. In other embodiments, however, the heat removal system 104 can be integrated into the computer cabinet 102, positioned outside the room 101, or situated in other suitable places.

[0013] The computer cabinet 102 can include an air inlet 114 for receiving cooling air from the room 101 or a floor plenum (not shown), an air outlet 116 for discharging air to the room 101, and a plurality of computer module compartments 120 (identified individually as first, second, and third computer module compartments 120a-c, respectively) arranged vertically between the air inlet 114 and the air outlet 116 in a chassis 110. Individual computer module compartments 120 hold a plurality of computer modules 112 oriented edgewise with respect to the flow of cooling air through the chassis 110.

[0014] The computer cabinet 102 can also hold a plurality of heat exchangers 118 in the chassis 110. As described in greater detail below with reference to FIGS. 1B-4, the individual heat exchangers 118 can be configured to receive a working fluid (not shown) from the heat removal system 104 via the supply line 106a. After flowing through the heat exchangers 118, the working fluid returns to the heat removal system 104 via the return line 106b. The working fluid can include hydrofluorocarbons, hydrochlorofluorocarbons, chlorofluorocarbons, ammonia, and/or other suitable refrigerants known in the art. The working fluid can include a vapor phase fluid, a liquid phase fluid, or a two-phase fluid when flowing through the heat exchangers 118.

[0015] The computer cabinet 102 can additionally include an air mover 130 (e.g., a fan) positioned proximate to the air inlet 114 to facilitate movement of the cooling air through the chassis 110 along a flow path 117. The air mover 130 can draw air from the room 101 or a floor plenum into the chassis 110 through the air inlet 114. The air then flows through the chassis 110 past the computer modules 112, and exits the chassis 110 via the air outlet 116.

[0016] The heat removal system 104 can include a pump 124 in fluid communication with a condenser 122. The condenser 122 can be a shell-and-tube type heat exchanger, a plate-and-frame type heat exchanger, or other suitable type of heat exchanger known in the art. The condenser 122 can include a working fluid inlet 126a for receiving heated working fluid returning from the computer cabinet 102, and a working fluid outlet 126b for supplying cooled working fluid to the pump 124. The condenser 122 can also include a coolant inlet 128a and a coolant outlet 128b for circulating chilled water, cooling water, or other suitable coolant (not shown) to cool the working fluid. The pump 124 can include a positive displacement pump, a centrifugal pump, or other suitable type of pump for circulating the working fluid back to the heat exchangers 118 via the supply line 106a.

[0017] During operation of the computer system 100, the air mover 130 draws air into the chassis 110 through the air inlet 114. The first heat exchanger 118a cools the air before it flows into the first compartment 120a. As the air flows through the first compartment 120a, the computer modules 112 in the first compartment 120a transfer heat to the air. The second heat exchanger 118b then cools the air before the air passes into the second compartment 120b by absorbing heat from the air into the working fluid. The air is similarly cooled by the third heat exchanger 118c before flowing into the third compartment 120c. The fourth heat exchanger 118d then cools the heated air leaving the third compartment 120c before the air is discharged to the room 101 via the air outlet 116.

[0018] In one embodiment, the working fluid is in phase transition between liquid and vapor as the working fluid leaves the heat exchangers 118. In other embodiments, the working fluid can have other phase conditions at this time. The heated working fluid from the heat exchangers 118 returns to the condenser 122 via the return line 106b. The coolant in the condenser 122 cools the working fluid before the pump 124 circulates the working fluid back to the heat exchangers 118.

[0019] Only a single computer cabinet 102 is shown in FIG. 1A for purposes of illustration and ease of reference. In other embodiments, however, supercomputers and other large computer systems can include a plurality of computer cabinets arranged in banks or other configurations. In such embodiments, the heat removal system 104 can provide working fluid to one or more of the computer cabinets 102 via an appropriately configured piping circuit. Further, although the heat exchangers 118 have been described above in the context of working fluid-type heat exchangers, in other embodiments, other types of heat exchangers can be used to inter-cool the air moving through the compartments 120 without departing from the spirit or scope of the present invention.

[0020] FIG. 1B is an enlarged perspective view of one of the heat exchangers 118 configured in accordance with an embodiment of the invention. The heat exchanger 118 can include a plurality of heat exchange elements 132 extending between and in fluid communication with an inlet manifold 134 and an outlet manifold 135. Although four heat exchange elements 132 are shown in FIG. 1B, in other embodiments, the heat exchanger 118 can include more or fewer heat exchange elements 132 depending on a number of factors including heat load, cost, manufacturability, etc.

[0021] The inlet manifold 134 can include a distribution section 137c extending between an inlet port 137a and a capped inlet end 137b. In the illustrated embodiment, the distribution section 137c includes a generally tubular structure (e.g., a section of a pipe or a tube) with a plurality of first slots 137d arranged along a length of the distribution section 137c. The first slots 137d are configured to receive first end portions of the heat exchange elements 132. In other embodiments, the distribution section 137c can have other configurations to accommodate other factors.

[0022] In the illustrated embodiment, the outlet manifold 135 is generally similar to the inlet manifold 134. For example, the outlet manifold 135 includes a collection section 139c extending between an outlet port 139a and a capped outlet end 139b. The collection section 139c includes a generally tubular structure with a plurality of second slots 139d arranged along a length of the collection section 139c in one-to-one correspondence with the first slots 137d. In other

embodiments, the outlet manifold 135 can have other configurations, including others that differ from the inlet manifold 134. For example, the collection section 139c can have a different cross-sectional shape and/or a different size than the distribution section 137c.

[0023] The individual heat exchange elements 132 can include a plurality of fins 142 extending from a passage portion 140. A first end portion 132a of the passage portion 140 is coupled to the inlet manifold 134 via the first slots 137d, and a second end portion 132b of the passage portion 140 is coupled to the outlet manifold 135 via the second slots 139d. In the illustrated embodiment, the passage portion 140 extends into both the inlet manifold 134 and the outlet manifold 135. In other embodiments, however, the ends of the passage portion 140 can be generally flush with the first and/or second slots 137d, 139d. Further details of several embodiments of the passage portion 140 are described below with reference to FIG. 1C.

[0024] FIG. 1C is an enlarged side view of two of the heat exchange elements 132 of FIG. 1B, configured in accordance with one embodiment of the invention. As illustrated in FIG. 1C, the heat exchange elements 132 can be at least generally parallel to each other with a gap D (e.g., from about 1 to about 2 cm, or any other desired spacing) therebetween. In other embodiments, however, at least some of the heat exchange elements 132 can be nonparallel to the other heat exchange elements 132. The gap D can form an air passage 136 in fluid communication with the air flow path 117. The air passage 136 allows cooling air to flow past the heat exchange elements 132 during operation of the computer system 100.

[0025] In certain embodiments, individual heat exchange elements 132 can be canted relative to the incoming air flow path 117a. For example, as illustrated in FIG. 1C, the heat exchange elements 132 can form an angle A of from about 10° to about 45°, preferably from about 15° to about 40°, and more preferably about 20° to about 30° relative to the air flow path 117a. In other embodiments, the heat exchange elements 132 and the air flow path 117a can form other suitable angles. Each of the heat exchange elements 132 can form the same angle or different angles relative to the air flow path 117. For example, the angles can increase or decrease (e.g., linearly, exponentially, etc.) from one heat exchange element 132 to another.

[0026] The individual heat exchange elements 132 can include a plurality of internal fluid channels 144 (identified individually as first, second, third, and fourth internal channels 144a-d, respectively). In the illustrated embodiment, the internal channels 144 have generally the same cross-sectional shape, e.g., a generally rectangular shape, and generally the same cross-sectional area. In other embodiments, however, the internal channels 144 can have other cross-sectional shapes, such as triangular shapes, circular shapes, oval shapes, and/or other suitable shapes and/or cross-sectional areas. In further embodiments, the internal channels 144 can have non-identical configurations, as described in more detail below with reference to FIG. 2.

[0027] Referring to FIG. 1B and FIG. 1C together, in operation, a working fluid (not shown) flows into the inlet manifold 134 via the inlet port 137a, as indicated by the arrow 131a. The inlet manifold 134 distributes the working fluid to the internal channels 144 at the first end 132a of each of the heat exchange elements 132. The working fluid flows across the heat exchange elements 132 from the first end 132a toward the second end 132b. As the working fluid flows across the

heat exchange elements **132**, the working fluid absorbs heat from cooling air flowing through the air passage **136** and/or past the fins **142**. As a result, in one embodiment, the working fluid can be at least partially vaporized (i.e., a two-phase fluid) at the outlet manifold **135**. In other embodiments, the working fluid can be sub-cooled at the outlet manifold **135**. In further embodiments, the working fluid can be substantially completely vaporized at the outlet manifold **135**. In all these embodiments, the collection section **139c** of the outlet manifold **135** collects the heated working fluid and returns the heated working fluid to the heat removal system **104** (FIG. 1A) via the outlet port **139a**, as indicated by the arrow **131b**.

[0028] Canting the heat exchange elements **132** can improve heat distribution along a length **L** (FIG. 1C) of the heat exchange elements **132**. For example, as the cooling air flows past the heat exchange elements **132**, the working fluid in one of the internal channels **144** (e.g., the fourth internal channel **144d**) can absorb heat from air streams that have not been significantly cooled by working fluid flowing through other internal channels **144** (e.g., the first, second, and/or third internal channels **144a-c**). As a result, heat distribution along the length **L** of the heat exchange element **132** can be more efficient than with heat exchange elements arranged parallel to the air flow. The canted heat exchange elements **132** can also increase the heat transfer area without significantly affecting the height of the heat exchanger **118**. Furthermore, the canted heat exchange elements **132** can improve energy distribution in the computer cabinet **102** (FIG. 1A) because the canted heat exchange elements **132** can deflect cooling air to other parts of the computer cabinet **102** during operation, as indicated by the arrow **117**.

[0029] FIG. 2 is a cross-sectional side view of a heat exchange element **232** having non-identical internal channels configured in accordance with another embodiment of the invention. As illustrated in FIG. 2, the heat exchange element **232** can include a plurality of internal channels **244** (identified individually as first, second, third, and fourth internal channel **244a-d**, respectively), and at least one internal channel **244** has a different internal configuration than others. For example, the cross-sectional area of the internal channels **244** can sequentially decrease from the first internal channel **244a** to the fourth internal channel **244d**. In other embodiments, the first and second internal channels **244a-b** can have a first cross-sectional area, and the third and fourth internal channels **244c-d** can have a second cross-sectional area, smaller than the first cross-sectional area. As the foregoing illustrates, in further embodiments, the internal channels **244** can have different cross-sectional shapes and/or other arrangements.

[0030] In operation, the different internal configurations of the internal channels **244** can allow the working fluid to have different mass flow rates when flowing through the internal channels **244**. For example, in the illustrated embodiment, the first internal channel **244a** has a larger cross-sectional area than that of the second internal channel **244b**. As a result, the mass flow rate of working fluid through the first internal channel **244a** will be greater than the mass flow rate of the working fluid through the second internal channel **244b** for a given fluid pressure.

[0031] Controlling the flow rate of the working fluid flowing through individual internal channels **244** can improve heat transfer performance of the heat exchange element **232**. The inventor has recognized that, in certain situations, the working fluid flowing through the first internal channel **244a** can be completely vaporized before and/or when it reaches

the outlet manifold **135** (FIG. 1B). The completely vaporized working fluid typically cannot efficiently transfer heat because of a low heat capacity. By increasing the flow rate of the working fluid flowing through the first internal channel **244a**, the working fluid can be at least a two-phase fluid when it reaches the outlet manifold **135**, thus improving the heat transfer efficiency.

[0032] In other embodiments, the heat exchange element **232** can include other features that affect the mass flow rate of the working fluid in the internal channels **244**. For example, individual internal channels **244** can include an orifice, a nozzle, and/or other flow restricting components. In another example, the heat exchange element **232** can include a barrier (not shown) that partially blocks the cross-section of at least one of the internal channels **244**.

[0033] FIG. 3 is a front view of a heat exchange element **332** having a fin configuration configured in accordance with a further embodiment of the invention. In this embodiment, the heat exchange element **332** includes a first fin portion **342a** and a second fin portion **342b** arranged along the air flow path **117**. The first fin portion **342a** can include a plurality of first fins **343a**, and the second fin portion **342b** can include a plurality of second fins **343b**, different than the first fins **343a**. For example, in the illustrated embodiment, the second fin portion **342b** can have a larger number of fins **343b** than the first fin portion **342a**. In another embodiment, the second fin portion **342b** can include different types of fins than the first fin portion **342a** (e.g., the second fins **343b** can have different heights, thicknesses, etc). In a further embodiment, the second fins **343b** can have a higher heat conductance than the first fins **343a**. In any of these embodiments, the second fin portion **342b** can have a higher heat transfer coefficient than the first fin portion **342a**.

[0034] Having different fin configurations along the air flow path **117** can improve the heat transfer efficiency between the working fluid and the cooling air. The inventor has recognized that if the fins have the same configuration along the length **L** of the heat exchange element **332**, the working fluid flowing through the fourth internal channel **144d** (FIG. 1C) is likely to be mostly liquid when it reaches the outlet manifold **135** (FIG. 1B). Thus, the heat transfer between the working fluid and the cooling air is limited because the mostly liquid working fluid typically has a latent heat capacity much lower than its heat of vaporization. The inventor has further recognized that the limiting factor in the heat transfer between the working fluid and the cooling air is the heat transfer rate between the fins and the cooling air. Thus, by increasing the heat transfer efficiency and/or capability of the second fin portion **342b**, the heat transfer between the working fluid in the fourth internal channel **144d** and the cooling air can be improved.

[0035] FIG. 4 is a partially exploded perspective view of a heat exchanger **418** configured in accordance with another embodiment of the invention and suitable for use in the computer system **100** of FIG. 1A. Many features of the heat exchanger **418** can be at least generally similar in structure and function to the heat exchangers **118** describe above. For example, the heat exchanger **418** can include a plurality of heat exchange elements **432** extending between an inlet manifold **434** and an outlet manifold **435**. The individual heat exchange elements **432** can include a plurality of fins **442** extending from a passage portion **440**. The passage portion **440** can be generally similar to the passage portion **140** of FIGS. 1B and 1C, or the passage portion **240** of FIG. 2.

[0036] The inlet manifold 434 can include a distribution section 437c extending between an inlet opening 437a and a capped inlet end 437b. The inlet manifold 434 can also include an inlet divider 448 extending between the inlet opening 437a and the inlet end 437b. The inlet divider 448 separates the distribution section 437c into a first inlet volume 450a and a second inlet volume 450b. The inlet divider 448 also separates the inlet opening 437a into a first inlet port 452a and a second inlet port 452b.

[0037] In the illustrated embodiment, the outlet manifold 435 is generally similar to the inlet manifold 434. For example, the outlet manifold 435 includes a collection section 439c extending between an outlet opening 439a and a capped outlet end 439b. The outlet manifold 435 can also include an outlet divider 458 that separates the collection section 439c into a first outlet volume 460a and a second outlet volume 460b. The outlet divider 458 also separates the outlet opening 439a into a first outlet port 462a and a second outlet port 462b.

[0038] The inlet and outlet dividers 448, 458 cooperate to separate the internal channels 144 (FIG. 1C) of individual heat exchange elements 432 into a first channel portion 444a corresponding to the first inlet/outlet volumes 450a, 460a and a second channel portion 444b corresponding to the second inlet/outlet volumes 450b, 460b. Thus, the first inlet volume 450a, the first channel portion 444a, and the first outlet volume 460a form a first flow path of the heat exchanger 418. Similarly, the second inlet volume 450b, the second channel portion 444b, and the second outlet volume 460b form a second flow path of the heat exchanger 418. The first and second flow paths are isolated from each other and arranged along the air flow path 117.

[0039] In operation, the heat exchanger 418 can receive a first working fluid portion via the first inlet port 452a, as indicated by arrow 470a, and a second working fluid portion via the second inlet port 452b, as indicated by arrow 472a. The first and second inlet volumes 450a-b distribute the first and second working fluid portions to the first and second channel portions 444a-b, respectively. The first and second working fluid portions flow across the heat exchange elements 432, as indicated by arrows 470b and 472b, respectively. As the first and second working fluid portions flow across the heat exchange elements 432, they absorb heat from the cooling air flowing past the fins 442. The first and second outlet volumes 460a-b collect the heated first and second working fluid portions and returns them to the heat removal system 104 (FIG. 1A) via the first and second outlet ports 462a and 462b, respectively, as indicated by arrows 470c and 472c, respectively.

[0040] The first and second working fluid portions can have different physical characteristics. For example, in one embodiment, the first working fluid portion can have a mass flow rate that is less than the second working fluid portion. In another embodiment, the first working fluid portion can have a higher heat transfer coefficient than the second working fluid portion. In a further embodiment, the first working fluid portion can have a lower boiling point than the second working fluid portion. In yet another embodiment, the first working fluid portion can have a higher heat of vaporization than the second working fluid portion.

[0041] By controlling the physical characteristics of the first and second working fluid portions, the heat exchanger 418 can have improved heat transfer performance compared to conventional heat exchangers. The inventor has recognized

that if the same working fluid is flowing through all the internal channels of the heat exchange elements 432, the working fluid in those channels proximate to the incoming cooling air is likely to be completely vaporized, while the working fluid in other channels spaced apart from the incoming cooling air may still be in liquid phase. Thus, by selecting appropriate heat transfer characteristics of the first and second working fluids, an operator can improve the heat transfer between the working fluid and the cooling air.

[0042] Although the inlet divider 448 and the outlet divider 458 are illustrated in FIG. 4 as being generally perpendicular to the air flow path 117, in other embodiments, at least one of the inlet divider 448 and the outlet divider 458 can be canted relative to the air flow path 117. In further embodiments, at least one of the inlet divider 448 and the outlet divider 458 can be omitted, and/or at least one of the first and second inlet/outlet volumes 450a-b, 460a-b can be standalone structures. For example, the first and second inlet volumes 450a-b can each include a generally tubular structure and spaced apart from each other.

[0043] FIG. 5 is a top view of a heat exchanger 518 configured in accordance with a further embodiment of the invention and suitable for use in the computer system 100 of FIG. 1A. Many features of the heat exchanger 518 can be at least generally similar in structure and function to the heat exchangers 118 describe above. For example, the heat exchanger 518 can include a plurality of heat exchange elements 532 (identified individually as first, second, third, and fourth heat exchange elements 532a-d, respectively) extending between a first manifold 534 and a second manifold 535. The individual heat exchange elements 532 can include a passage portion 540 and have a plurality of fins 542 extending from the passage portion 540. The passage portion 540 can be generally similar to the passage portion 140 of FIGS. 1B and 1C, or FIG. 2.

[0044] The first manifold 534 can include a first intermediate section 537c extending between a first opening 537a and a capped first end 537b. The first manifold 534 can also include a first divider 548 extending between the first opening 537a and the first end 537b. The first divider 548 separates the first intermediate section 537c into a first distribution volume 550a and a first collection volume 550b. The first divider 548 also separates the first opening 537a into a first inlet port 552a and a first outlet port 552b.

[0045] The first distribution volume 550a and the first collection volume 550b are in fluid communication with only a portion of the heat exchange elements 532. For example, in the illustrated embodiment, the first distribution volume 550a is in fluid communication with the second and fourth heat exchange elements 532b, 532d, and the first collection volume 550b is in fluid communication with the first and third heat exchange elements 532a, 532c. In other embodiments, the first manifold 534 can also have other flow configurations.

[0046] The second manifold 535 can include a second intermediate section 539c extending between a second opening 539a and a capped second end 539b. The second manifold 535 can also include a second divider 558 extending between the second opening 539a and the second end 539b. The second divider 558 separates the second intermediate section 539c into a second distribution volume 560a and a second collection volume 560b. The second divider 558 also separates the second opening 539a into a second inlet port 562a and a second outlet port 562b.

[0047] The second distribution volume **560a** and the second collection volume **560b** are in fluid communication with only a portion of the heat exchange elements **532**. For example, in the illustrated embodiment, the second distribution volume **560a** is in fluid communication with the first and third heat exchange elements **532a**, **532c**, and the second collection volume **560b** is in fluid communication with the second and fourth heat exchange elements **532b**, **532d**. In other embodiments, the second manifold **535** can also have other flow configurations.

[0048] The heat exchanger **518** can thus have a first flow path from the first inlet port **552a** to the second outlet port **562b** via the first distribution volume **550a**, the second and fourth heat exchange elements **532b**, **532d**, and the second collection volume **560b**. The heat exchanger **518** can also have a second flow path from the second inlet port **562a** to the first outlet port **552b** via the second distribution volume **560a**, the first and third heat exchange elements **532a**, **532c**, and the first collection volume **550b**.

[0049] In operation, the heat exchanger **518** can receive a first working fluid portion via the first inlet port **552a**, as indicated by arrow **570a**, and a second working fluid portion via the second inlet port **562a**, as indicated by arrow **572a**. The first and second distribution volumes **550a**, **560a** distribute the first and second working fluid portions to corresponding heat exchange elements **532**. The first working fluid portion then flows across the second and fourth heat exchange elements **532b**, **532d** in a first direction, as indicated by arrow **570b**. The second working fluid portion then flows across the first and third heat exchange elements **532a**, **532c** in a second direction, as indicated by arrow **572b**. In the illustrated embodiment, the second direction is generally opposite the first direction. In other embodiments, the first and second directions can form an angle of about 120° to about 180°. As the first and second working fluid portions flow across the heat exchange elements **532**, the cooling air flowing past the fins **542** heats the first and second working fluid portions. The first and second collection volumes **550b**, **560b** collect the heated first and second working fluid portions and return them to the heat removal system **104** (FIG. 1A) via the first and second outlet ports **552b**, **562b**, as indicated by arrows **570c**, **572c**, respectively.

[0050] By flowing the first and second working fluid portions in generally opposite directions, the heat exchanger **518** can have improved heat transfer efficiency compared to conventional heat exchangers. The inventor has recognized that the heat transfer efficiency decreases as the first and/or second portions of working fluid flow across the heat exchange elements. Thus, if the first and second working fluid portions flow in the same direction, one side of the heat exchanger **518** may have insufficient heat transfer. However, by alternating the flow directions of the first and second working fluid portions, the heat transfer efficiency between the first and second working fluid portions and the cooling air can be improved.

[0051] From the foregoing, it will be appreciated that specific embodiments of the invention have been described herein for purposes of illustration, but that various modifications may be made without deviating from the spirit and scope of the invention. For example, the heat exchangers shown in FIGS. 4 and 5 can also incorporate the heat exchange elements shown in FIGS. 2 and 3. In another example, the heat exchanger shown in FIG. 1B can also incorporate the inlet/outlet manifolds of FIG. 4 or FIG. 5. Further, while advantages associated with certain embodiments of the invention

have been described in the context of those embodiments, other embodiments may also exhibit such advantages, and not all embodiments need necessarily exhibit such advantages to fall within the scope of the invention. Accordingly, the invention is not limited, except as by the appended claims.

1. A computer system, comprising:
 - a computer cabinet having:
 - an air inlet;
 - an air outlet spaced apart from the air inlet; and
 - a plurality of computer module compartments positioned between the air inlet and the air outlet, wherein the air inlet, the air outlet, and the computer module compartments define an air flow path through the computer cabinet; and
 - a heat exchanger positioned between two adjacent computer module compartments, the heat exchanger including a plurality of heat exchange elements canted relative to the air flow path.
2. The computer system of claim 1 wherein the heat exchange elements form an angle of from about 10° to about 45° relative to the air flow path.
3. The computer system of claim 1 wherein individual heat exchange elements include a plurality of fins between a first end and a second end, and wherein at least one of the passage portions and the plurality of fins are canted relative to the air flow path.
4. The computer system of claim 3 wherein the passage portion includes a plurality of internal channels extending between the first end and the second end.
5. The computer system of claim 1 wherein the heat exchange elements include a first heat exchange element and a second heat exchange element, and wherein the first heat exchange element forms a first angle relative to the air flow path and the second heat exchange element forms a second angle relative to the air flow path, the first angle being different than the second angle.
6. A computer system, comprising:
 - a computer cabinet having a plurality of computer module compartments positioned between an air inlet and an air outlet;
 - a heat exchanger positioned between two adjacent computer module compartments, the heat exchanger including a plurality of heat exchange elements in fluid communication with an inlet manifold and an outlet manifold, wherein the individual heat exchange elements include a plurality of internal channels configured to receive a working fluid from the inlet manifold and transfer the working fluid to the outlet manifold, the individual internal channels having different cross-sectional shapes.
7. The computer system of claim 6 wherein the internal channels have different cross-sectional areas.
8. The computer system of claim 6 wherein the air inlet, the air outlet, and the computer module compartments define an air flow path through the computer cabinet, and wherein the internal channels have cross-sectional areas that sequentially decrease along the air flow path.
9. (canceled)
10. A computer system, comprising:
 - a computer cabinet having a plurality of computer module compartments positioned between an air inlet and an air outlet; and
 - a heat exchanger positioned between two adjacent computer module compartments, the heat exchanger includ-

ing a plurality of heat exchange elements individually having a passage portion and a plurality of fins extending from the passage portion, wherein the plurality of fins include a first fin portion having a first configuration and a second fin portion having a second configuration different than the first configuration, wherein the air inlet, the air outlet, and the computer module compartments define an air flow path through the computer cabinet, and wherein the first and second fin portions are arranged at least partially along the air flow path.

11. The computer system of claim 10 wherein the first fin portion is upstream of the second fin portion along the air flow path.

12. The computer system of claim 10 wherein the first fin portion is upstream of the second fin portion along the air flow path, and wherein the second fin portion has a larger number of fins than the first fin portion.

13. The computer system of claim 10 wherein the first fin portion is upstream of the second fin portion along the air flow path, and wherein the second fin portion has a higher heat conductance than the first fin portion.

14. A computer system, comprising:

a computer cabinet having a plurality of computer module compartments positioned between an air inlet and an air outlet, wherein the air inlet, the air outlet, and the computer module compartments define an air flow path through the computer cabinet; and

a heat exchanger positioned between two adjacent computer module compartments, the heat exchanger including a first flow path and a second flow path in fluid isolation from the first flow path.

15. The computer system of claim 14 wherein the first and second flow paths are arranged sequentially along the air flow path.

16. The computer system of claim 14 wherein the heat exchanger includes

an inlet manifold having an inlet divider separating the inlet manifold into a first inlet volume and a second inlet volume;

an outlet manifold having an outlet divider separating the outlet manifold into a first outlet volume and a second outlet volume; and

a plurality of heat exchange elements positioned between the inlet manifold and the outlet manifold, the individual heat exchange elements including a passage portion having a first channel portion and a second channel portion, wherein the first channel portion is in fluid communication with the first inlet volume and the first outlet volume, and wherein the second channel portion is in fluid communication with the second inlet volume and the second outlet volume.

17. The computer system of claim 16 wherein the first inlet volume, the first channel portion, and the first outlet volume at least partially define the first flow path, and wherein the second inlet volume, the second channel portion, and the second outlet volume at least partially define the second flow path.

18. The computer system of claim 16, further comprising a first working fluid portion in the first flow path and a second working fluid portion in the second flow path, and wherein the first working fluid portion and the second working fluid portion have different physical characteristics.

19. The computer system of claim 18 wherein the first working fluid portion has at least one of a higher flow rate, a higher heat transfer coefficient, a lower boiling point, a higher heat of vaporization than the second working fluid portion.

20. The computer system of claim 14 wherein the heat exchanger includes

a first manifold having a first divider separating the first manifold into a first inlet volume and a first outlet volume;

a second manifold having a second divider separating the second manifold into a second inlet volume and a second outlet volume;

a first heat exchange element in fluid communication with the first inlet volume and the second outlet volume while being isolated from the second inlet volume and the first outlet volume; and

a second heat exchange element in fluid communication with the second inlet volume and the first outlet volume while being isolated from the first inlet volume and the second outlet volume, wherein the first inlet volume, the first heat exchange element, and the second outlet volume at least partially define the first flow path and the second inlet volume, the second heat exchange element, and the first outlet volume at least partially define the second flow path.

21. The computer system of claim 20, further comprising a first working fluid portion in the first flow path and a second working fluid portion in the second flow path, and wherein the first working fluid portion and the second working fluid portion have different flow directions when flowing through the first and second heat exchange elements.

22. The computer system of claim 20, further comprising a first working fluid portion in the first flow path and a second working fluid portion in the second flow path, and wherein computer system further includes a directing means for directing the first working fluid portion to flow through the first heat exchange element in a first direction and the second working fluid portion to flow through the second heat exchange element in a second direction opposite of the first direction.

23. A method for operating a computer cabinet having a plurality of computer module compartments positioned between an air inlet and an air outlet and a heat exchanger positioned between two adjacent computer module compartments, the method comprising:

flowing a first working fluid portion along a first flow path of the heat exchanger;

flowing a second working fluid portion in a second flow path of the heat exchanger, the first and second flow paths being in fluid isolation from each other; and

controlling at least one characteristic of at least one of the first and second working fluid portions.

24. The computer system of claim 23 wherein controlling at least one characteristic includes controlling a flow rate, a heat transfer coefficient, a boiling point, and/or a heat of vaporization of the first and/or second working fluid portions.

25. The computer system of claim 23 wherein controlling at least one characteristic includes flowing the first and second working fluids in generally opposite directions across the heat exchanger.