

(12) **UK Patent Application** (19) **GB** (11) **2 368 114** (13) **A**

(43) Date of A Publication 24.04.2002

(21) Application No 0126685.7

(22) Date of Filing 14.05.1999

Date Lodged 07.11.2001

(30) Priority Data

(31) 9810309 (32) 15.05.1998 (33) GB
(31) 9828321 (32) 23.12.1998
(31) 9828317 (32) 23.12.1998
(31) 9901018 (32) 19.01.1999

(62) Divided from Application No 0027459.7 under Section 15(4) of the Patents Act 1977

(51) INT CL⁷
B67D 1/08

(52) UK CL (Edition T)
F4H H2K

(56) Documents Cited
US 3826829 A
Online (WPI) abstract for JP460010033 B

(58) Field of Search
UK CL (Edition T) A2B BMH19 , F4H H2K
INT CL⁷ B67D 1/04 1/08 , C12H 1/18 , F25D 17/02
Online: EPODOC, JAPIO, WPI

(71) Applicant(s)
Brandbrew SA
(Incorporated in Luxembourg)
Rue Goethe, 11, BP 1107, Luxembourg

(74) Agent and/or Address for Service
Barker Brettell
138 Hagley Road, Edgbaston, BIRMINGHAM,
B16 9PW, United Kingdom

(72) Inventor(s)
Simon Daniel Scullion
Peter Thomas Foster
Stephen Paul Smith

(54) Abstract Title
A Beverage

(57) A beverage 170 in an open-topped vessel 172, said beverage comprises a water content and a dissolved gas content, and said beverage further comprising ice 188A, 188B having a cooling effect on the beverage, said ice being formed in the beverage from water of said water content. The beverage may be subjected to the effect of ultrasound signals. Immediately before the beverage is delivered into the vessel said beverage may be cooled to a temperature below the freezing point of water at ambient atmospheric pressure. The ultrasound signals may be applied externally of said vessel. The ultrasound signals may be applied internally of said vessel to the cooled beverage. A dispense outlet or nozzle for dispensing the beverage may be adapted to act as an ultra-sonic emitter to provide ultras sound signals. The beverage may be an alcoholic beverage such as a beer or a cider. The ice may comprise a slush.

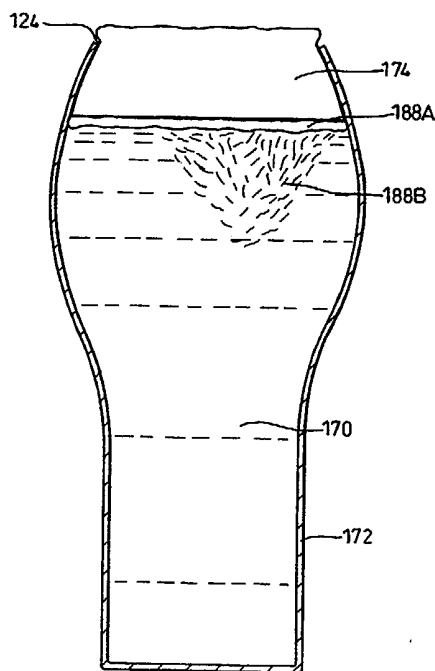

Fig. 19

GB 2 368 114 A

1/8

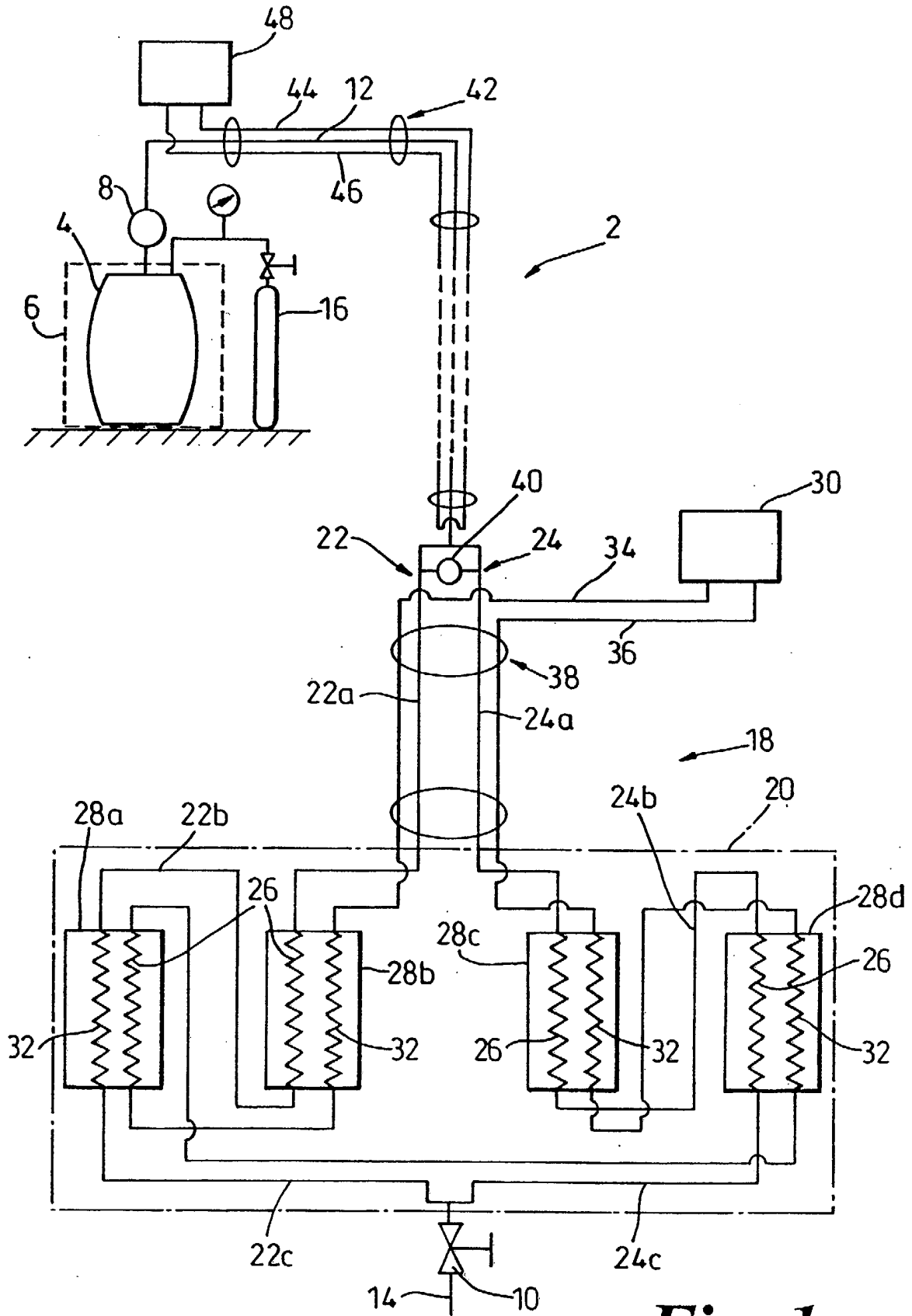

Fig. 1

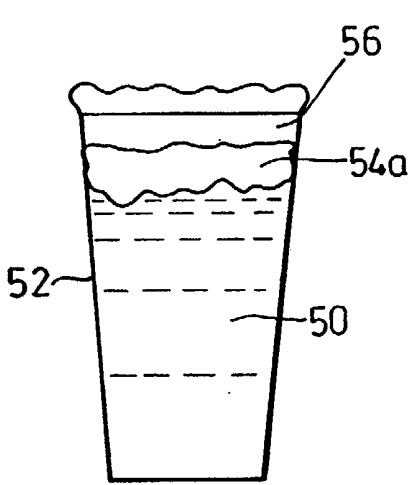

Fig. 2

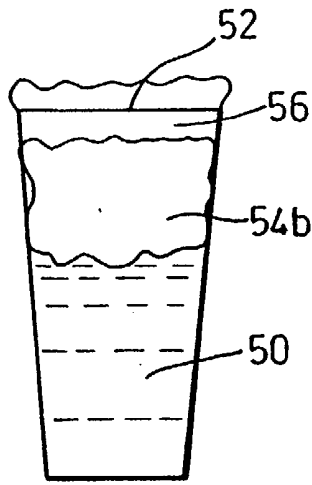

Fig. 3

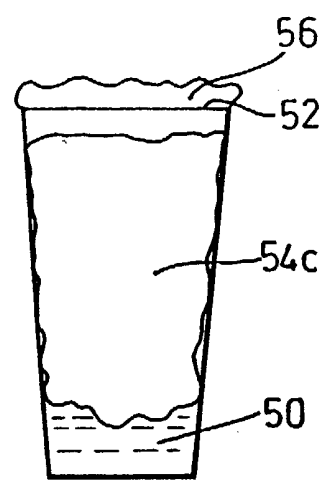

Fig. 4

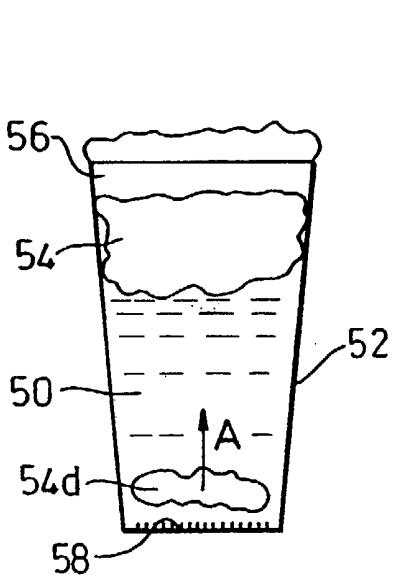

Fig. 5

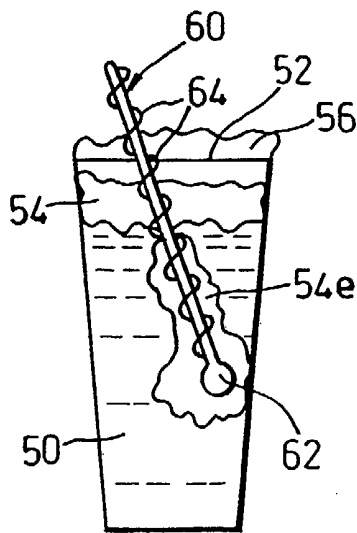

Fig. 6

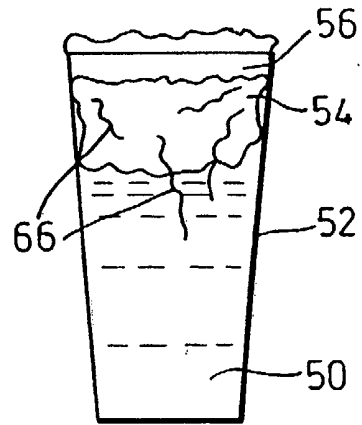

Fig. 7

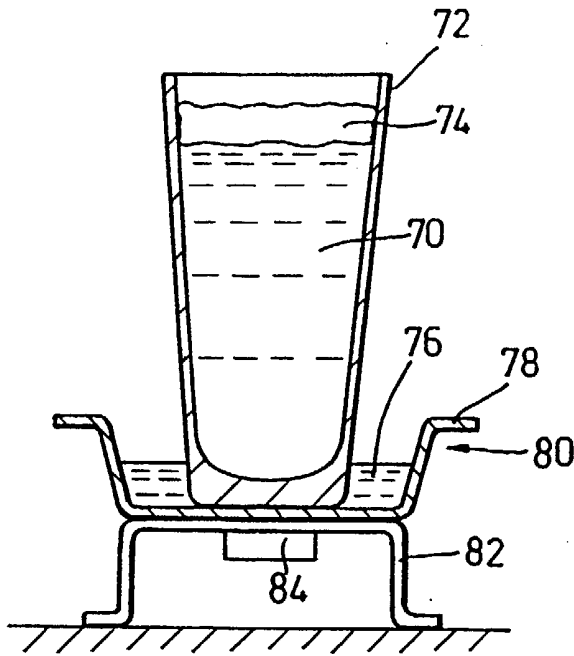

Fig. 8

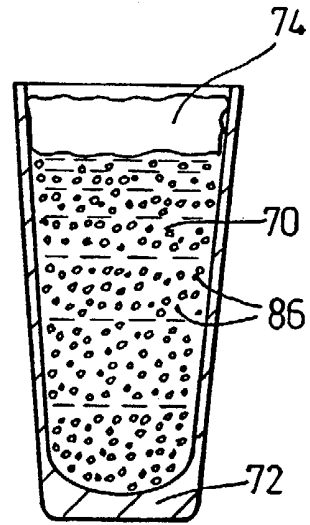

Fig. 9

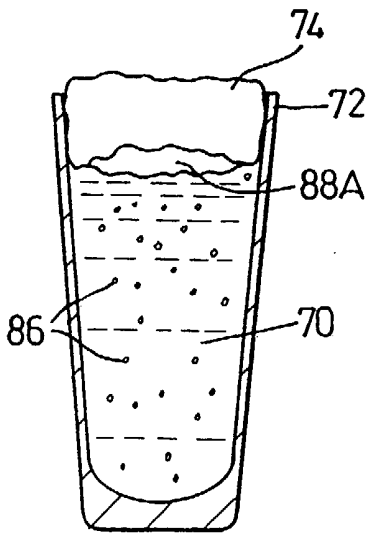

Fig. 10

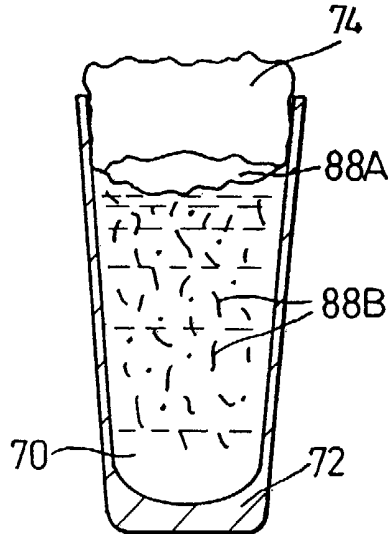

Fig. 11

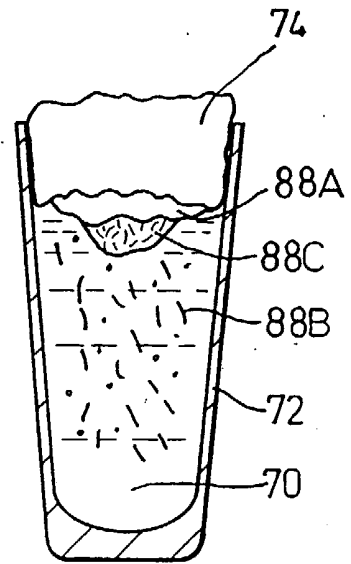

Fig. 12

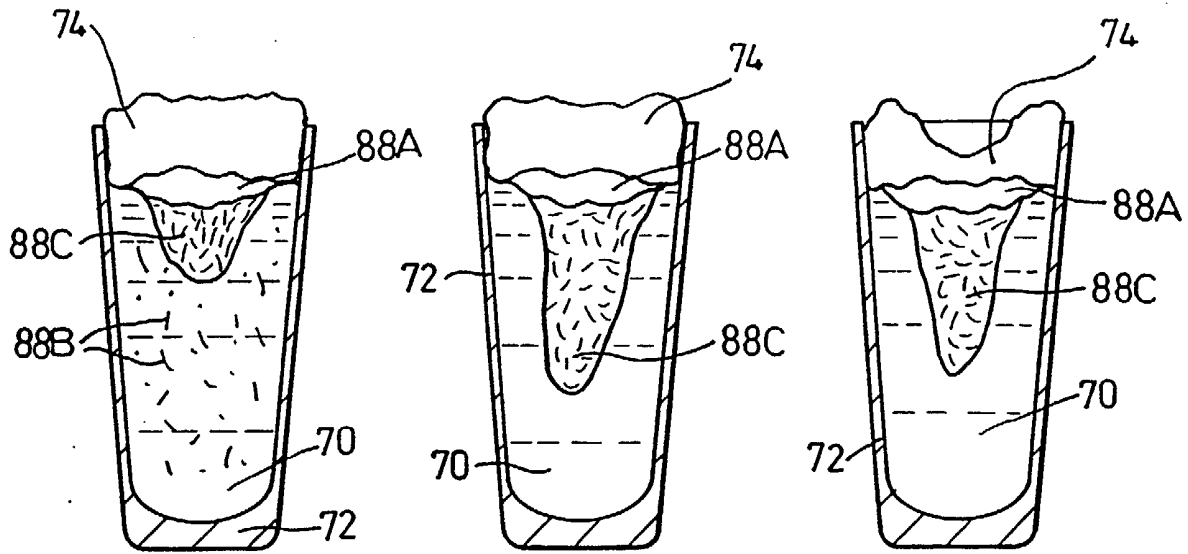

Fig. 13

Fig. 14

Fig. 15

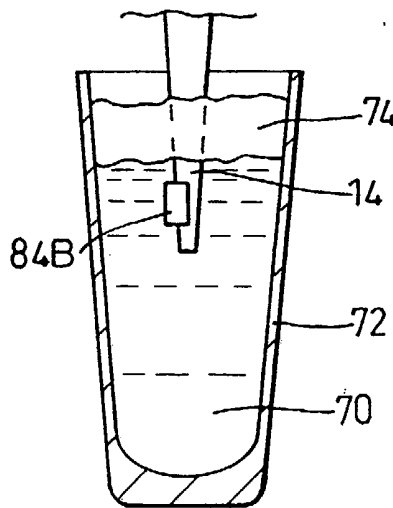
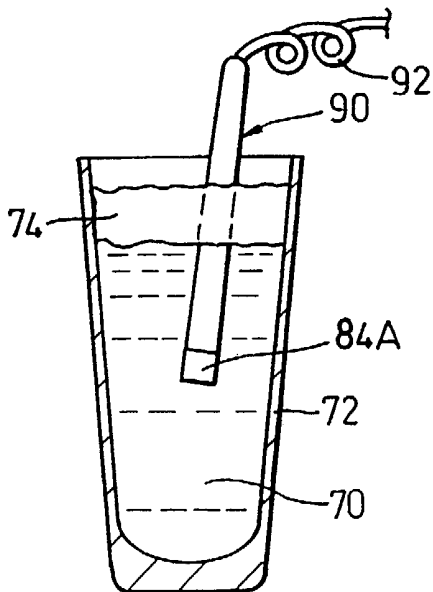

Fig. 16

Fig. 17

5/8

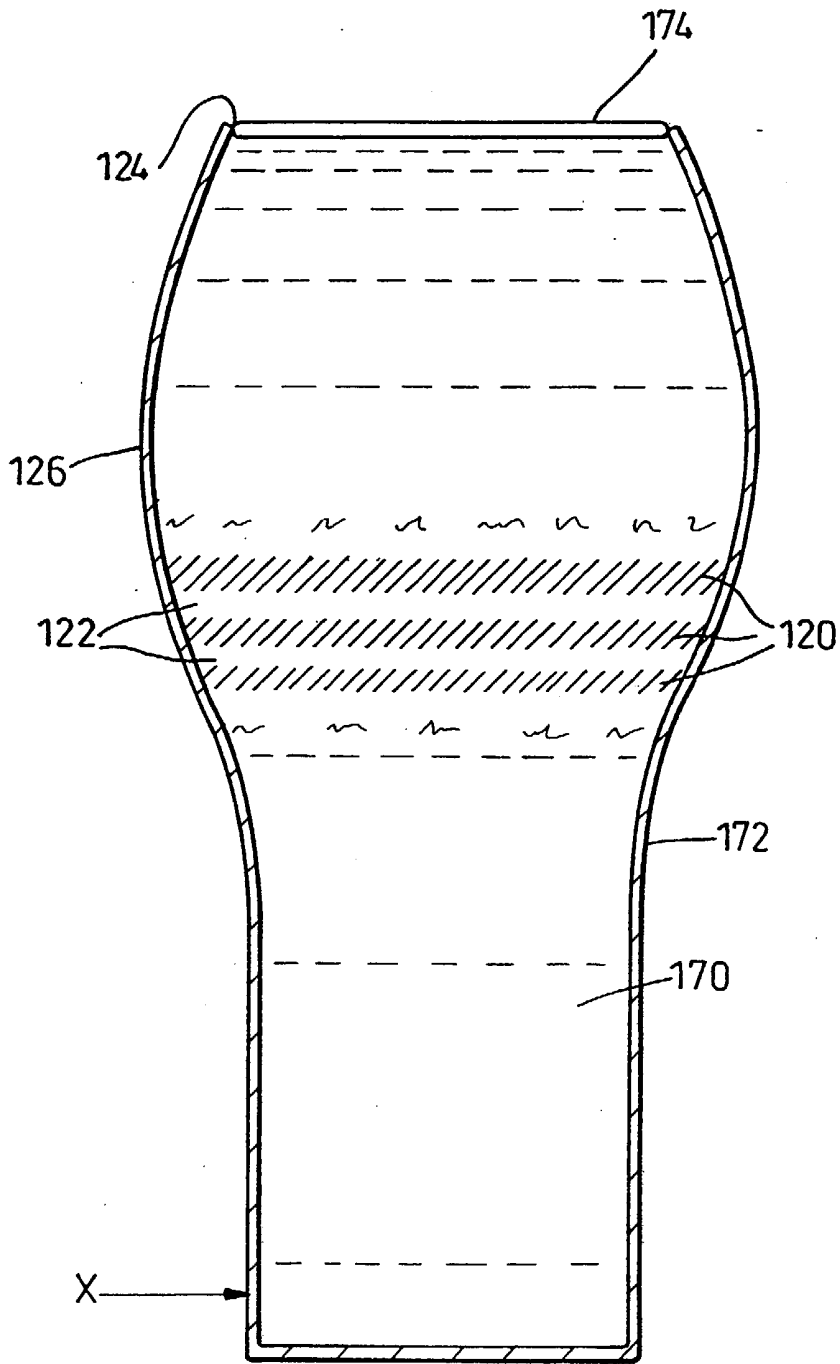

Fig. 18

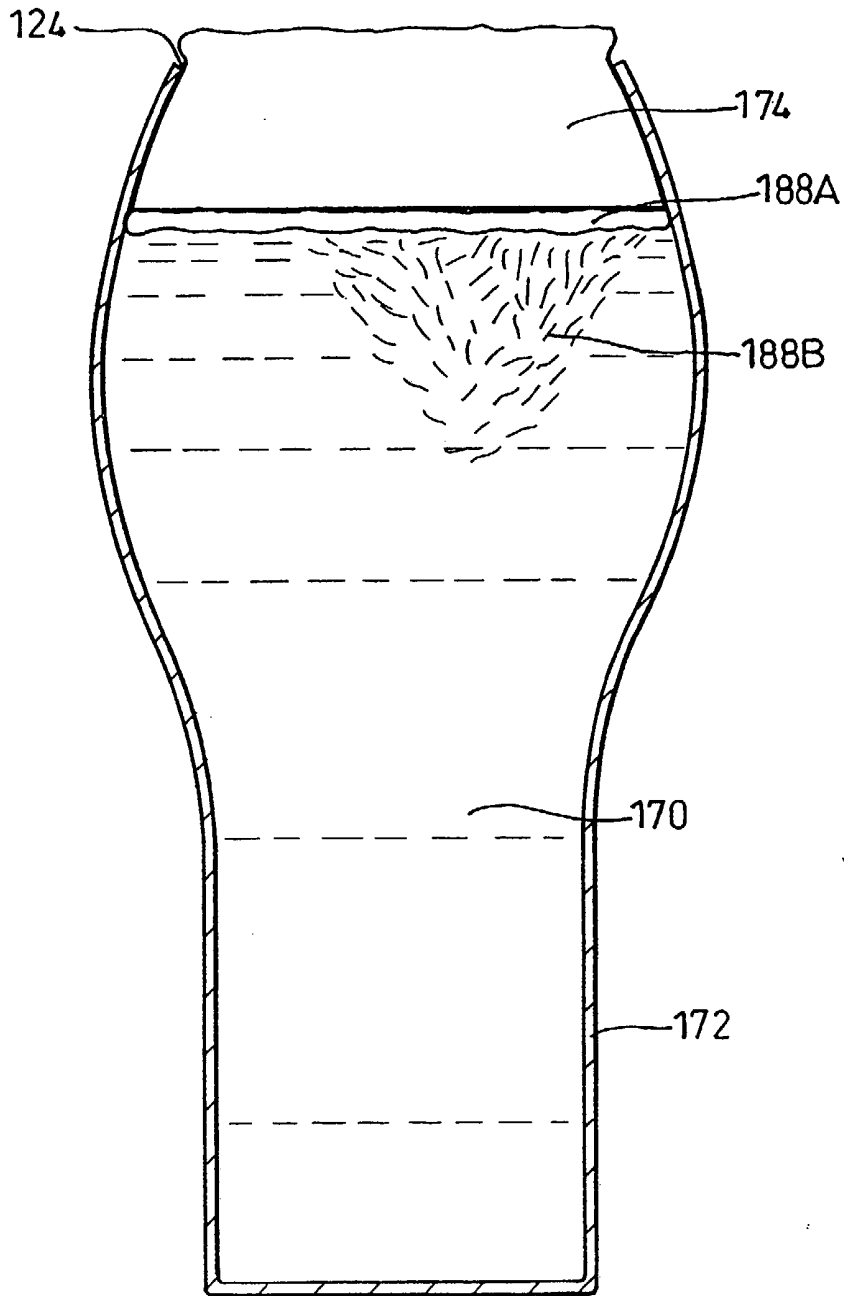

Fig. 19

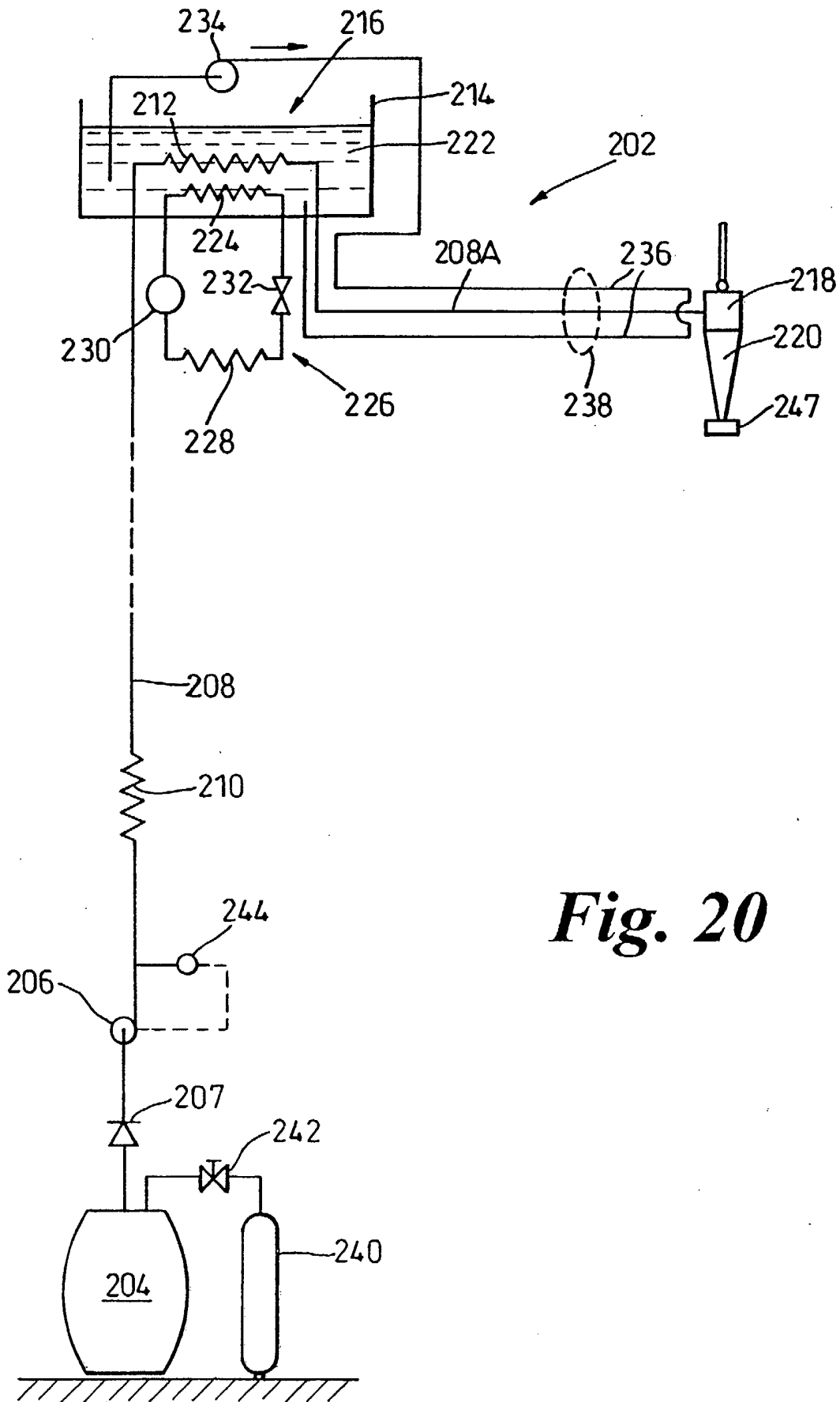

Fig. 20

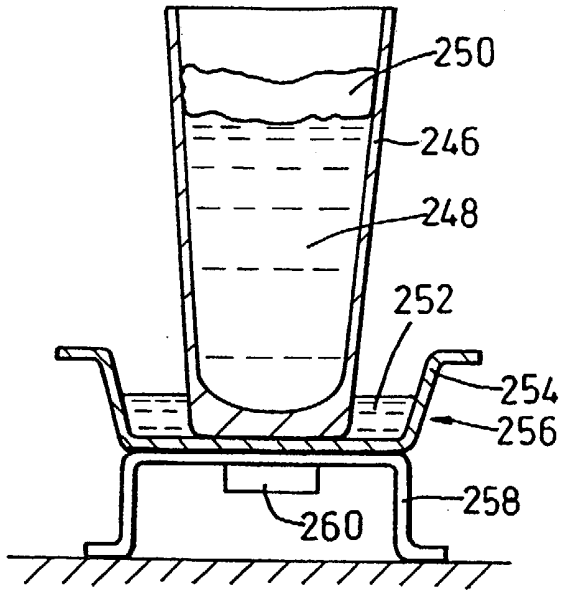

Fig. 21

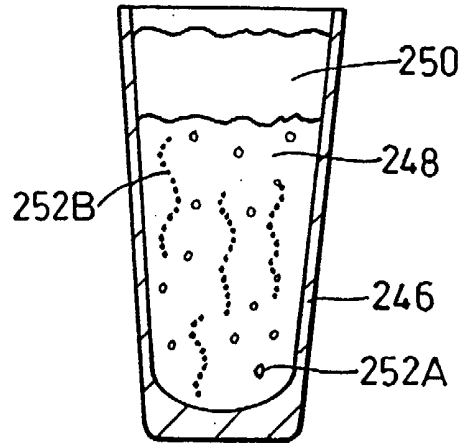

Fig. 22

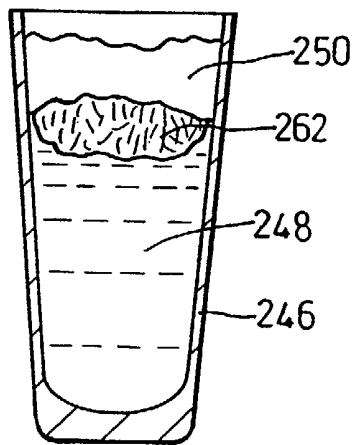

Fig. 23

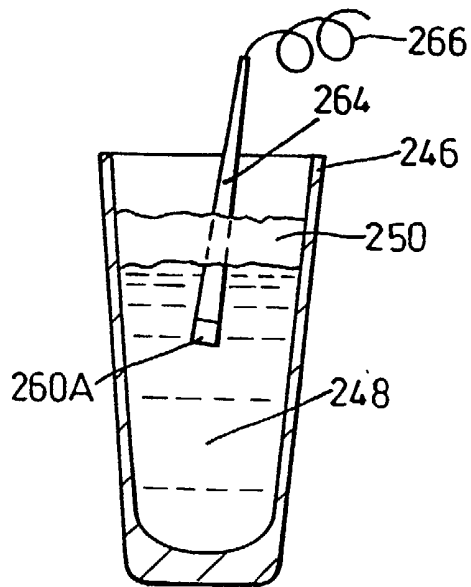

Fig. 24

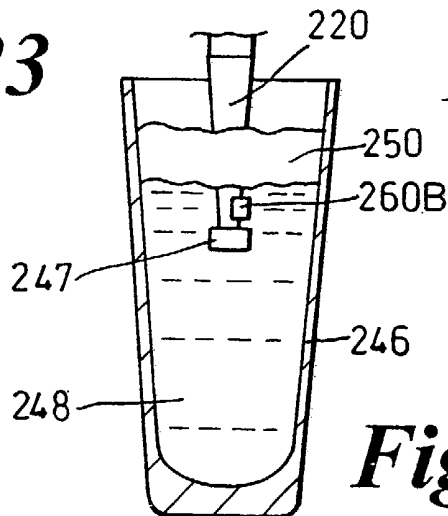

Fig. 25

A BEVERAGE

This invention relates to a beverage and to methods of presenting or serving a beverage or providing a visual display in a beverage.

5

The beverage concerned comprises a water content and a dissolved gas content.

The beverage may be an alcoholic beverage or a non-alcoholic beverage. For example, the beverage may be a beer, a cider, a flavoured alcoholic beverage, for example an alcoholic lemonade or other alco-pop style of drink, or a so-called low alcoholic drink. The term "beer" embraces lager, ale, porter and stout and includes a beverage comprising hops flavouring, an alcohol content derived from malt and fermentation, a water content, and a dissolved gas content.

15

One object stated in relation to matter disclosed in our published application Serial No. GB 2 340 924A was to provide a cool beverage using ice therein in a way which a consumer may find more agreeable because dilution of the drink cannot occur.

20

Another object stated in relation to matter disclosed in our published application Serial No. GB 2 340 924A was to provide a beverage which the existence of cooling ice therein may be sustained whereby the drink may be kept cold for an extended period of time.

25

Another object stated in relation to matter disclosed in our published application Serial No. GB 2 340 924A was to provide a beverage in which a head thereon may be sustained.

30

Another object stated in relation to matter disclosed in our published application Serial No. GB 2 340 924A was to provide a beverage in which ice may develop therein as an interesting visual display.

5

As disclosed in our published application Serial No. GB 2 340 924A there can be provided a beverage in an open-topped vessel, said beverage comprising a water content and a dissolved gas content, and in said vessel the beverage having a head of foam over ice, said ice being formed in the beverage from water of said water content.

10

The vessel may be any suitable vessel, for example a drinking vessel, for example a glass.

15

Preferably there is a layer of ice adjacent the head, in contact with the head. Preferably there is a projection of ice extending downwards, away from the head, and being provided in the region of the head. The projection of the ice may depend directly from the head, or from a layer of ice beneath the head.

20

The ice is preferably made of many small crystals of ice, rather than a single solid mass. The ice is preferably slushy in character, rather than being a solid mass. There may be more than one kind of ice formation in the beverage. There may be a fine, powdery ice. There may be a flaky ice, of the order of 1 or 2mm or 3mm or 4mm, or more, in their longest dimension of the flakes.

25

The beverage, which may be coloured as distinct from white or water clear, may have bands, or stripes, across it at different heights, the bands possibly being white layers where nucleation is taking place, and beverage-coloured layers interposed between the white layers where less

30

nucleation is taking place. This effect may be achieved by using ultrasound on the vessel, for example a glass, of beverage. The white bands and the interposed beverage-coloured bands may be of substantially the same thickness.

5

The white bands interspersed by beverage-coloured bands may exist for a matter of seconds, rather than minutes, and typically exist for 1 to 10 seconds, preferably about 3 to 6 seconds. The white bands/beverage-coloured bands interspersed may exist for substantially the same time as ultrasound is applied to the vessel of beverage.

Nucleation means may be provided to encourage the formation of the ice crystals and/or head in the beverage when it is in a vessel. The nucleation means is preferably the administration of ultrasound, preferably to the bottom portion of a vessel of beverage, but it could be other forms of nucleation inducement. For example the vessel and/or dispense tap/nozzle (or an object to be inserted into the vessel of beverage) may have a roughened surface/high surface area surface to encourage nucleation (such as a sintered surface, etched surface, or a surface of ground material, such as glass); or a rapid and suitably large pressure drop may be provided to induce nucleation; or mechanical agitation may be provided; or the beverage may be arranged to have turbulent flow to promote nucleation; or an amount of liquid, possibly highly supersaturated with gas, may be introduced or injected; or gas may be otherwise introduced, or injected, or the glass may be vibrated in some way (e.g. by being exposed to sound waves, or the vessel may be vibrated in some other way); or by introducing a chemical (e.g. tablet) or device which generates bubbles (for example a chemical pellet may effervesce or dissolve, releasing bubbles).

30

As disclosed in our published application Serial No. GB 2 340 924A there can be provided a method of keeping a beverage in an open-topped vessel cool, said beverage comprising a water content and a dissolved gas content, and said method comprising forming ice in the beverage in the open-topped vessel having a cooling effect on the beverage, said ice being formed in the beverage from water of said water content.

As disclosed in our published application Serial No. GB 2 340 924A there can be provided a method of sustaining cooling ice in a beverage in an open-topped vessel, said beverage comprising a water content and a dissolved gas content, and wherein said ice is formed in the beverage from water of said water content, said method comprising providing a head of foam on the beverage such that in the vessel said ice is covered by the head which acts as head insulation above the ice against heat directed towards the ice from above the head.

As disclosed in our published application Serial No. GB 2 340 924A there can be provided a method of sustaining a head on beverage in an open-topped vessel, said beverage comprising a water content and a dissolved gas content, said method comprising providing a head on the beverage and forming ice in the beverage from water of said water content, and in said vessel said ice having a cooling effect on the head from below an upper part of the head.

25

As disclosed in our published application Serial No. GB 2 340 924A there can be provided an open-topped vessel of a beverage the beverage comprising a water content and a dissolved gas content and being able to form a head as the beverage is dispensed into the vessel, the vessel of beverage having a head overlying an ice formation made of many ice crystals, the ice formation having been

30

produced by ice forming in the beverage as it was dispensed or after it was dispensed into the vessel.

5 Preferably the vessel has a transparent or translucent wall or at least has a window of transparent or translucent material.

10 Preferably the ice formation extends substantially the width of the mouth of the vessel, or completely across the width of the mouth. It may comprise substantially homogenous ice-crystals in a head-contacting region or layer. Alternatively, the ice crystals that contact the head may not be substantially homogeneous.

15 The ice formation may have a projection extending away from the head. The projection may comprise flakes of ice that are larger than the ice at the ice-head boundary.

The ice at the ice-head interface may have been formed before the ice flakes of the projection.

20 The beverage may have been subjected to ultrasound signals and may be draught beverage delivered into the vessel. Before the draught beverage is delivered into the vessel, and preferably immediately before, the beverage may be cooled to a temperature below the freezing point of water at ambient atmospheric pressure.

25

As disclosed in our published application Serial No. GB 2 340 924A there can be provided a method of serving draught beverage in an open-topped vessel, said beverage comprising a water content and a dissolved gas content, and said method comprising cooling 30 the beverage to a temperature below the freezing point of water at ambient atmospheric pressure, and delivering the cooled beverage into

said vessel, said cooled beverage being subjected to the effect of ultrasound signals or to the effect of other ice and/or gas bubble nucleation means.

5 The ultrasound signals may be applied externally of said vessel, and/or the ultrasound signals may be applied internally of said vessel to the cooled beverage. In the latter case an ultra-sonic emitter provided as or incorporated into a probe may be disposed in the beverage in the vessel. If desired a dispense outlet or nozzle from which the beverage is
10 delivered into the vessel may be adapted to act as an ultra-sonic emitter to provide aforesaid ultrasound signals to beverage in the vessel. Such signals may be applied to the beverage as it passes through the dispense outlet.

15 Ultrasound signals can be applied to beverage not only after it has been delivered into the vessel, but also whilst it is being delivered.

 The ultrasound signals may have a frequency in the range of 20kHz to 70kHz. For example, the ultrasound signals may have a frequency of
20 substantially 30kHz.

 A mass of aforesaid ice may develop downwards in the beverage below the head.

25 Preferably, the vessel is chilled before the beverage is delivered thereinto. The vessel may be chilled to a temperature of substantially 4°C, or the vessel may be chilled to a temperature less than 4°C. For example, the vessel may be chilled to a temperature of substantially 0°C.

30 Prior to the delivery, and preferably just prior to the delivery, a draught beverage may be cooled to a temperature in a range of between

substantially -1°C and substantially -12°C and may issue at a temperature substantially in that range into the vessel. If desired, the beverage may be cooled to a temperature between substantially -4°C and substantially -6°C . The greater the alcohol strength by volume (abv), the lower the temperature to which the alcoholic beverage may be cooled. We may aim to achieve a dispense temperature of about -5°C for a lager (or other drink) with out 4.5 abv (or to substantially -4°C or substantially -6°C).

Preferably, the vessel has a wall portion of sufficient transparency to allow the contents of the vessel to be visible through said wall portion. Thus the vessel may be a glass drinking vessel.

Preferably the beverage is a pale colour for example the colour of a pale beer. If desired the beverage can be a lager, or a cider.

Aforesaid dissolved gas may comprise carbon dioxide and/or may comprise nitrogen. A dissolved nitrogen content in the beverage, for example an alcoholic beverage may be in the range of substantially zero parts per million (p.p.m) to substantially 100 p.p.m. For some beverages, for example certain lagers, substantially 40 p.p.m. A dissolved carbon dioxide content may approach zero % by volume or be greater. Said carbon dioxide may be substantially at any of the following levels or in a range defined between any of the following levels; zero vols/vol, 0.5 vols/vol, 1 vols/vol, 1.4 or 1.5 vols/vol, 2.0 vols/vol, 2.2 or 2.4 vols/vol, 3 vols/vol, 4 vols/vols or 5 vols/vol or above.

If desired, the ultrasound signals can be accompanied by a mechanically or electrically produced audible performance and/or a visible light display. The audible performance may be tuneful or musical sound. The visible light displays may comprise visible flashes of light.

If desired the beverage can be subjected to the ultrasound within an enclosure arranged to conceal the vessel from view from at least one side of said enclosure.

5 According to a first aspect of the present invention, there is provided a beverage comprising a water content and a dissolved gas content, said beverage being provided to be used in a manner wherein prior to being drunk said beverage is cooled to a temperature below the freezing point of water at ambient atmospheric pressure and delivered in a
10 vessel to be drunk exposed to ambient atmospheric pressure, and wherein in said vessel aforesaid gas bubbles out of the beverage and at least a portion of said water content becomes ice.

 According to a second aspect of the present invention, there is
15 provided a beverage to be available on draught and comprising a water content and a dissolved gas content, said beverage being provided to be used in a manner wherein prior to being drunk the draught beverage is to issue, at a temperature below the freezing point of water at ambient atmospheric pressure, from an outlet into a vessel open to ambient
20 atmospheric pressure so that aforesaid gas bubbles out of the beverage and at least a portion of said water content becomes ice.

 If desired, the vessel which preferably may be a drinking vessel, can have a shape or formation to promote formation of the ice. For
25 example, the vessel may have an internal surface to provide nucleation sites to promote formation of the ice. Said surface may have at least a surface portion which is roughened. At least a wall portion of vessel can be arranged to change colour automatically with variation in temperature. Said wall portion may comprise thermo-chromic material.

Desirably, the gas is a non-oxidising gas. This can avoid or at least slow deterioration of the beverage. The gas comprises carbon dioxide and/or nitrogen. By cooling the beverage and forming ice therein, this appears to, initially at least, reduce the rate of release of dissolved gas from the beverage, for example lager, and appears to improve the drinking sensation, taste, flavour or bite. We believe that this is a combination of the low drinking temperature (maintained by the ice) and the greater amount of retained gas in the beverage.

The presence of the ice can provide an interesting and attractive feature which can be particularly fascinating as the ice may expand at a noticeable rate throughout the beverage after the vessel is filled. To add to the interest, the ice may include therein one or more streaks or regions of one or more colours which contrast(s) with the colour of the ice and/or beverage.

The aforesaid ice may be, or may have, the character of slush.

According to a third aspect of the present invention, there is provided a method of serving a draught beverage which comprises a water content and a dissolved gas content, said method comprising issuing the draught beverage from an outlet into an open topped vessel, prior to said issuing, storing or handling the beverage in a manner which impedes loss of the aforesaid dissolved gas from the beverage and cooling said beverage to a temperature below the freezing point of water at said ambient atmospheric pressure, and in said vessel aforesaid gas bubbles out of the beverage and at least a portion of said water becomes ice.

According to a fourth aspect of the present invention, there is provided a method of providing a visual display or effect within an open topped vessel having at least a portion of wall of some transparency, said

method comprising providing a draught beverage comprising a water content and a dissolved gas content, issuing the draught beverage from an outlet into a said vessel, prior to said issuing, storing or handling the beverage in a manner which impedes loss of aforesaid dissolved gas from
5 the beverage and cooling said beverage to a temperature below the freezing point of water at said ambient atmospheric pressure and a visual display or effect developing in the beverage in the vessel, said visual display or effect comprising aforesaid gas bubbling out of the beverage and formation of ice due to at least a portion of said water becoming ice.

10

Formation of ice can develop in the vessel so as to increase the amount and extent of the ice from substantially an upper level of the beverage downwards through the beverage.

15

At least a wall portion of the vessel may change colour automatically with variation in temperature. Said wall portion may comprise thermo-chromic material.

20

An implement can be inserted into the beverage in the vessel to encourage formation of said ice. For example, the implement may be a thermometer, or it may be a swizzle-stick.

25

Colouring material or dye can be provided to form at least one coloured streak or region in the beverage and/or ice, the colour of said material or dye being in contrast to that of the ice and/or beverage so as to be visible.

30

The aforesaid implement may be used to add the colouring material or dye to the beverage and/or ice.

In one method, the beverage may issue at substantially -4°C into the vessel and thereafter the temperature of the beverage in the vessel may rise almost immediately to at least substantially -3°C

5 As disclosed in our published application Serial No. GB 2 340 924A there can be provided a beverage dispense apparatus comprising cooling means adapted to cool a beverage to below 0°C , a dispense tap, and beverage dispense pipework adapted to convey the beverage to the dispense tap, the arrangement being such that the
10 apparatus is adapted to dispense the beverage cooled to below the point at which ice would normally form in the beverage if the beverage were left standing at atmospheric pressure and if nucleation means were provided for the standing beverage, and in which the undispensed beverage in the apparatus does not freeze solid.

15

 Preferably, the apparatus includes pump means and the beverage dispense pipework may include a portion which circulates beverage past the dispense tap when the dispense tap is closed, the fact that cooled undispensed beverage is kept flowing tends to prevent the formation of
20 ice blockages at the dispense tap.

 The beverage may be kept flowing past the dispense tap (or through it when it is open) at substantially all times that the beverage is at a temperature at which ice may otherwise form at the dispense tap or, in
25 the beverage dispense pipework.

 Preferably, there is a cold circulation loop in which is provided at least one cooling means and which connected to the dispense tap, beverage in the circulation loop being kept cold by the cooling means and
30 being kept circulating by pump means provided in the circulation loop. There may be a plurality of cooling means (e.g. heat exchangers) in the

circulation loop. There may be a plurality of dispense taps associated with the circulation loop.

5 Beverage upstream of the circulation loop may be cooled to a temperature about that at which ice may form in the beverage under the conditions of temperature and pressure experienced by the beverage in the pipework upstream of the circulation loop.

10 As disclosed in our published application Serial No. GB 2 340 924A there can be provided apparatus to supply draught beverage, comprising beverage heat exchange means, a beverage outlet for cold beverage from said heat exchange means to issue from the outlet, openable and closable valve means to control supply of beverage to said outlet, and a beverage circulation loop for beverage to circulate in said
15 loop.

The beverage can circulate in the loop when the valve means is closed. Preferably, the loop comprises pump means to circulate said beverage.
20

A purpose of circulating the beverage is to reduce the risk of or avoid freezing beverage blocking a beverage supply path to the outlet. Said loop may include a beverage flow passage in said heat exchange means.
25

The apparatus can comprise a unit or dispenser mountable on a counter of a drinks' bar and comprising the heat exchange means and the outlet.

A beverage flow path can connect a reservoir of the draught beverage to the heat exchange means. The flow path may comprise at least a portion of the loop.

5 The flow path may divide into a plurality of beverage routes, and the loop may comprise one or more of the routes.

Intermediate the reservoir and the first-mentioned heat exchange means the beverage may be subject to the effect of second beverage cooling heat exchange means.

The reservoir may be subjected to cooling.

15 If desired, the second heat exchange means may act on at least a portion of the loop.

Coolant common to the first and second heat exchange means may circulate therethrough.

20 Beverage cooling heat exchange means may act on the beverage intermediate said reservoir and loop.

25 It is extremely difficult to serve a glass of draught cider with a head of froth or foam so that the head lasts for any appreciable time. Though it is possible to create a head by dispensing the cider from a font containing a sparkler, the head quickly disappears. Because the use of a sparkler slows the delivery rate of the cider, it takes longer to deliver a measured volume than if the sparkler were not used, and because the head quickly vanishes anyway some people think use of a sparkler pointless and take it off the font - sometimes without permission.

30

Another object stated in relation to the matter disclosed in our published application Serial No. GB 2 340 924A was to provide a method of serving draught cider containing a dissolved gas content so that a head
5 on the delivered draught cider in a vessel, for example a drinking glass, is more stable and remains for a longer period of time than a head on cider served by hitherto known methods.

As disclosed in our published application Serial No.
10 GB 2 340 924A, there can be provided a method of serving draught cider in an open-topped vessel and wherein said cider comprises a water content and a dissolved gas content, said method comprising cooling the cider to a temperature below the freezing point of water at ambient atmospheric pressure, and delivering the cooled cider into said vessel, said cooled
15 cider being subjected to the effect of ultra-sound signals.

The cider may be cooled to a temperature in the range of substantially on -1°C to substantially -12°C . For example, the cider may be cooled to substantially -6°C . The greater the alcohol strength by
20 volume the lower the temperature to which the cider may be cooled.

If desired, the cooled cider may issue from a dispense outlet through a sparkler. However, the cooled cider may pass through an orifice plate in a dispense outlet from which the cider issues.
25

Preferably the open-topped vessel is chilled before receiving the cider. The vessel may be chilled to substantially 4°C or may be chilled to a temperature lower than 4°C . For example, the vessel may be chilled to substantially 0°C .
30

Said ultra-sound signals may have a frequency in the range of substantially 20kHz to substantially 70kHz. For example, the ultra-sound signals may have a frequency of substantially 30kHz.

5 The ultra-sound signals can be applied externally of said vessel to said vessel.

 The ultra-sound signals may be applied internally of said vessel to the cooled cider. Thus an ultra-sonic signal emitter may be disposed in
10 the cider in the vessel for emitting ultra-sound signals into the cider in the vessel.

 The dispense outlet from which the cooled cider issues into said vessel may be adapted to act as an ultra-sonic signal emitter to provide
15 aforesaid ultra-sound signals. Aforesaid ultra-sound signals may be applied to aforesaid cider flowing through the dispense outlet.

 The dissolved gas content may comprise carbon dioxide and/or nitrogen. The carbon dioxide may approach zero % by volume or be
20 greater, and/or the nitrogen content may approach zero parts per million (p.p.m.) or be greater for example, the carbon dioxide content may be substantially 1.8% by volume and/or the nitrogen content may be substantially 18 parts per million (p.p.m.).

25 As disclosed in our published application Serial No. GB 2 340 924A there can be provided cider in an open-topped vessel wherein said cider has a dissolved gas content and water content, and wherein said cider has a head of foam over ice, said ice being formed from water of said water content.

As disclosed in our published application Serial No. GB 2 340 924A there can be provided a method of sustaining a head on cider in an open-topped vessel wherein said cider comprises a water content and a dissolved gas content, said method comprising providing a head on the cider and forming ice in the cider from water of said water content, and in said vessel said ice forming a layer covered by said head.

The invention will now be further described by way of example with reference to the accompanying drawings in which:-

10

Figure 1 is a diagrammatic view of apparatus for delivering cooled draught beverage;

Figures 2 to 4 show diagrammatically in elevation a drinking vessel filled with draught beverage delivered by the apparatus in Figure 1 to illustrate successive changes or variations in the beverage after delivery thereof into a drinking vessel;

Figures 5 to 7 respectively show diagrammatic side elevations illustrating modifications in the way the delivered beverage may be served in the drinking vessel;

Figure 8 is a diagrammatic view showing in elevation a drinking vessel filled with a beverage delivered by the apparatus in Figure 1, the vessel being shown standing on apparatus represented diagrammatically to apply ultrasound signals to the beverage;

Figures 9 to 15 show diagrammatically in elevation successive changes in the development or variations in a head on the beverage subsequent to the beverage being subjected to ultrasound signals and also to development or variation in ice formed in the beverage;

Figure 16 is a diagrammatic view of an alternative method of applying ultrasound signals to the beverage;

5 Figure 17 is a diagrammatic view of yet a further method of applying ultrasound signals to the beverage;

Figure 18 shows a pint of lager being excited by ultrasound;

10 Figure 19 shows the pint of lager in Figure 18 after it has been allowed to stand for three minutes;

Figure 20 is a diagrammatic view of apparatus for delivering cooled draught cider;

15

Figure 21 is a diagrammatic view showing in elevation a drinking vessel filled with cider delivered by the apparatus in Figure 20, the vessel being shown standing on apparatus represented diagrammatically (and similar to that in Figure 8) to apply ultra-sound signals to the cider;

20

Figures 22 and 23 show diagrammatically in elevation successive changes in the development of the variations in the head on the cider subsequent to the cider being subjected to ultra-sound signals and also to development of or variations in ice formed in the cider;

25

Figure 24 is a diagrammatic view of an alternative method of applying ultra-sound signals to the cider, and;

Figure 25 is a diagrammatic view of yet a further method of
30 applying ultra-sound signals to the cider.

With reference to Figure 1, apparatus for delivering cold draught beverage is indicated at 2.

5 The draught beverage is stored in a keg or cask 4 which may be made of metal. The cask 4 can be stored in a cold-room known per se in public houses or clubs and/or, if desired, in a more specific cold or cooled enclosure 6, for example a tank contained a chilled mixture of water and ethylene glycol. As stated above the beverage has a water content and a dissolved gas content. This gas may be any suitable non-oxidising gas, for example carbon dioxide and/or nitrogen. The amount
10 of gas dissolved in the beverage may be within the usual known range for beverages, and the pressure within the cask 4 and the remainder of the supply apparatus (described below) may also be within the usual known range for beverages supplied on draught.

15

The beverage may be a beer which term includes lager, ale, porter, or stout, or may be cider. The dissolved carbon dioxide content may be greater than substantially 1 vols/vol or 2 vols/vol and may be substantially 2.2 volumes per volume, and/or the dissolved nitrogen
20 content may be substantially 25 p.p.m. to 35 p.p.m. If desired the carbon dioxide content may be substantially 4 vols/vol or substantially 5 vols/vol. The alcohol content may be between 2.5% abv to 6 or 7% abv, preferably 4-5% abv, $\pm 1\%$ abv.

25

The beverage may be a flavoured alcoholic beverage.

A pump 8, arranged to operate substantially only when the manually operable valve 10 is open, is provided to pump beverage from the cask 4 along a pipe 12 ultimately to the valve 10 and a dispense outlet
30 14 therefrom. In known manner, a blanket or atmosphere of non-oxidising/pressurised gas (for example carbon dioxide and/or nitrogen) is

provided in the cask 4 from a suitable supply 16 and assists the pump 8 in the extraction of the beverage.

5 A beverage dispense unit is indicated generally at 18 and has a cover indicated by interrupted lines 20. The dispense unit may be mounted at or in the vicinity of a drinks' bar - for example on the top of, or incorporated into, a counter of the bar.

10 In proximity to the cover 20 the pipe 12 divides into two flow paths 22 and 24, each leading to the valve 10. One is formed by piping 22a, 22b, 22c and passages 26 in heat exchangers 28a and 28b, and the other is formed by piping 24a, 24b, 24c and passages 26 in heat exchangers 28c and 28d.

15 A chiller unit 30 circulates coolant through passages 32 in the heat exchangers 28 in series by a system comprising a coolant flow pipe 34 and a coolant return pipe 36. Beverage pipes 22a and 24a can be bundled together in known manner with the coolant pipes 34 and 36 to form a python 38. The heat exchangers 28 may be plate heat exchangers.

20

A circulation pump 40 which may operate continuously, extends between the flow paths 22 and 24 adjacent to the junction between the pipe 12 and the flow paths. Thus, the flow paths 22, 24 and the pump 40 form a circulation loop 22, 24, 40 around which beverage is continuously
25 circulated when valve 10 is closed.

As suggested in Figure 1, in the beverage dispense unit 18, the heat exchangers 28 are within the cover 20, whilst the valve 10 and outlet 14 can be on its exterior, and a portion of the circulation loop comprised
30 by the pump 40 and sections of pipes 22a and 24a is also external of the cover and may be exposed to ambient temperature at the bar.

If desired, the pipe 12 may be incorporated in known manner into another cooling python 42 comprising flow and return pipes 44 and 46, carrying coolant from and back to a chiller unit 48.

5

Overall, the beverage arrangement - and particularly that provided by the dispense unit 18 by the heat exchangers 28 - so cools the beverage that the beverage issuing from the outlet 14 when valve 10 is opened is at a temperature below the freezing point of water at the ambient atmospheric pressure. For example the beverage may issue at a temperature in the range of substantially -1°C to substantially -12°C into a drinking vessel or drinking glass. The range may be substantially -4°C to substantially -6°C . A target temperature of -5°C is aimed for if we use a beverage with about 4.5% abv.

15

When the valve 10 is closed, the beverage is circulated automatically around the loop 22, 24, 40 so it cannot stand still and start to freeze and block the supply path to valve 10.

20

In the case of draught beverages, for example beers, conventionally served with a head, the outlet 14 may include a known orifice plate, or other device, to promote foaming.

With reference to Figure 2, when a draught beverage 50 is delivered from the outlet 14 (Figure 1) into a drinking vessel 52 (for example a glass) the beverage is exposed to ambient atmospheric pressure and ambient or room temperature, the beverage temperature starts to increase, for example to -3°C . Almost immediately, a slug of ice 54a forms near the top of the vessel 50 at the upper level of the beverage, the ice being caused (we believe) as a result of nucleation sites resulting from the forming of bubbles of dissolved gas. If the beverage 50 has a head 56

30

of foam the ice forms just below the head. The or a greater part of the ice may be in the nature of slush and is formed from the water already forming the beverage. The slug of ice grows as indicated at 54b in Figure 3 and 54c in Figure 4 until it may substantially occupy the vessel

5 52. The growth of ice (in, say, a pint glass) can be accomplished in a minute or two, is fascinating to watch and can give rise to interesting visual effects based on the growth of the ice and the bubbling off of the gas. Another interesting visual effect is that cooled beverages delivered into a drinking vessel from the apparatus in Figure 1 swirl in the vessel

10 for a longer time period than beverages which have not been cooled.

Not only does the formation of the ice give rise to interesting visual effects, but the existence of the ice helps to keep the drink cool longer. Also, since the ice is formed from the water in the beverage, the

15 beverage is not diluted by the ice. In fact, for an alcoholic beverage, the overall amount of alcohol remains the same in the container when the ice forms, but since water is being used for the ice, the alcoholic strength of the remaining liquid beverages increases until the ice melts.

20 The vessel 52 may be shaped or formed to encourage formation of the ice. In Figure 5, a region 58 (having a rough surface) is provided to encourage formation of nucleation sites to promote formations of a further ice slug 54d which rises as indicated by arrow A to enlarge the ice slug 54 developing from the top of the vessel 52.

25 In Figure 6, formation of further ice 54e in the body of the beverage 50 is encouraged by the insertion therein of an elongate implement or rod 60 represented in Figure 6 by a swizzle-stick having formations 62 and 64 at its lower end and shank respectively which

30 further encourage development of nucleation sites. In another instance, the rod 60 may be a thermometer body which can also be used to take the

temperature of the drink to see if it has risen sufficiently high for it to be safe to drink. The implement can be used to push the ice around.

5 In Figure 7, coloured regions or streaks are shown in the ice 54
and beverage 50. These coloured formations are formed by the release of
non-toxic, edible, colouring materials or dyes into the beverage 56. The
colouring material or dye, which stands out visually from the ice and
beverage, may be injected into the beverage, or may be introduced into
the beverage by or on the aforesaid implement.

10

It is preferable for the vessel 52 to have a wall of sufficient
transparency so that the formation of the ice slug 54 in the beverage 50
can be observed and its changing nature visually appreciated.

15

The drinking vessel 52 can be formed of, or have external surface
areas formed of, material (for example thermo-chromic material) which
automatically changes colour with temperature change. Apart from this
being a further interesting visual effect, the attainment of one particular
colour may signal that the beverage is at a suitable temperature for
20 drinking.

25

Whilst any kind of beverage having a water and dissolved gas
content may be used, we believe that lager demonstrates a visual nature
or character of the invention.

30

With reference to Figure 8, a draught beverage 70 (which may be a
beer, for example a lager) is delivered from the outlet 14 (Figure 1) into
a drinking vessel 72, for example a glass which is preferably rather tall
and preferably has a clear or transparent wall.

Preferably, the vessel 72 is chilled before it receives the beverage. The vessel 72 may be chilled to a temperature of substantially 4°C or less. For example a known bottle chiller may be used to chill the vessel 72 to substantially 4°C whilst a known glass froster may chill the vessel 5 to substantially 0°C. A head of foam is shown at 74 and preferably this is some way below the top of the vessel 72 when the vessel contains a full measured volume, for example a pint of the beer.

Immediately after the cold beverage is poured into the chilled 10 vessel 72 (or a few seconds after), the vessel is placed in a shallow depth of water 76 in a dish part 78 of an ultrasound generating apparatus 80 in which the dish 78 is securely mounted or affixed against a base part 82 containing an ultrasonic emitter 84. The emitter 84 may be arranged to emit ultrasound signals in a frequency range of substantially 20kHz to 15 70kHz. For example the beverage may be subject to ultrasound signals of a frequency of substantially 30 kHz or some other frequency selected from the aforesaid range, the water layer 76 providing an ultrasound for any desired period, though usually a short period of a few seconds, for example substantially one to five seconds and more specifically about 20 three or four seconds. The user may be able to vary the length of time that the ultrasound is applied, for example by having to hold down a switch, or by altering the setting on a control.

The result in a short time (perhaps a few seconds to the order of 25 ten seconds) is shown in Figure 9 in which the exposure to ultra-sonic signals has promoted a fairly dense sudden formation of a mass of bubbles 86 of the dissolved gas throughout the liquid beverage. This causes the head 74 to increase in height. As shown in Figure 10, the head 74 may rise out of the vessel 72. The gas bubbles form nucleation sites 30 encouraging the quick formation of a mass of ice 88A just below the head. This ice 88A may be of a rather slushy character. For a period the

mass of slush 88A grows and the head 74 rises as shown in Figure 11 but the bubbles of gas are no longer so numerous. Nevertheless, they can act as nucleation sites encouraging there at the formation of ice 88B in the body of the beverage, this ice 88B may be more in the nature of flakes, for example snow type flakes, which rise and agglomerate to form a flaky mass 88C of ice on the underside of the slushy ice mass 88A. As indicated in Figure 12 and 13 the ice flakes continue to form for a period, rise and extend the ice mass 88C downwards through the beverage 70.

10 Going from the stage shown in Figure 8 to that in Figure 14 may only take one or two minutes so the increase in gas bubbling and the formation and visible development of the ice takes place fairly quickly and can be interesting and rather amazing phenomena to observe through the glass 72.

15 To enhance the theatre, drama or wonder of the event for a customer at the drinks' bar the operation of the apparatus 80 may be accompanied by an automatically (or manually actuated) occurring audible performance which may be mechanically or electrically produced using sound apparatus giving out dramatic, musical or tuneful sounds. In addition to, or as an alternative, the operation of the apparatus 80 may be, possibly automatically, accompanied by a visual lights display, for example visible flashes of light. These may stimulate flashes of lightening. In that case the audible performance may comprise noise resembling thunder.

25 If desired, the vessel 72 when subject to the ultrasound may be concealed from the view of the customer in a bar. For example, it may be concealed from view on one or more sides in an enclosure which may be on the counter or proximate thereto, which enclosure may be represented as a "magic" or magician's box or cabinet.

Preferably, the beverage is a pale colour. For example the beverage may be a pale coloured beer, for example a lager.

5 Besides the ice forming in the beverage 70 being an intriguing sight, it helps show the customer the beverage is cold and that it has not been diluted by addition of ice from water other than that of the beverage.

10 The good head 74 provides insulation of the ice, particularly from overhead heat, which helps sustain the ice for longer and thus the duration of its cooling effect. Also the ice below the head 74, helps sustain the existence of the head which may last for ten minutes, fifteen minutes or most preferably for twenty minutes or so.

15 In Figure 15, the head 74 though starting to collapse (at its centre and move away from the vessel's wall) after the elapse of some time, for example fifteen or so minutes, is still stubbornly remaining, insulating the ice and giving the beverage an attractive presentation in the vessel 72.

20 An alternative method of applying the ultrasound signals is represented in Figure 16 in which after the apparatus 2 in Figure 1 has dispensed a vessel or glass 72 of beverage 70 an ultrasound probe 90 powered through cable 92 is dipped into the beverage for emitter 84A to give out ultrasound signals. The probe 90 may be inserted into the
25 beverage before the full measured amount is supplied to the vessel.

In Figure 12, the dispense outlet 14 has been arranged to act as an ultrasonic probe, for example by providing it with an ultrasonic emitter 88B.

The ultrasound probe 14 in Figure 12 may emit ultrasound signals whilst beer is passing through it to the vessel 72, and/or may become partially immersed in the beverage as shown and emit ultrasound signals into the beverage 70 in the vessel 72 whilst the measured volume of beverage is still being supplied or after it has been supplied.

Figure 18 shows another glass 172 (for example a pint) of beverage 170 in this case lager, being excited (as indicated by arrow X) at the base only by an ultrasound emitter, for example by standing the glass of beverage in couplant (water) for example as shown in Figure 8. Figure 18 shows the glass 172 after it has been excited by the ultrasound for about three seconds or so, and whilst it is still being excited by ultrasound and whilst a head 174 of foam is beginning to form. As will be seen, in addition to general bubble formation at a relatively modest level throughout the volume of the beverage 170, there is increased activity in a series of horizontal "white bands" about half-way up the height of the glass 172. Interspersed between the white bands 120 are bands 122 which are less white-coloured i.e. more beerage or lager coloured. There are typically two to four white bands 120 visible, but increased bubble formation may occur above and below the "banded region" 120, 122.

The formation of the bands 120, 122 gives the glass of beverage an attractive appearance for the few seconds that they last. It is believed that they may be associated with the formation of standing waves in the glass 172 due to the ultrasound excitation, and may represent areas of the glass which might vibrate the most (although this belief is speculative and is not to be held to be limiting). The bands 120, 122 may form generally in the central height of the glass, but they may not be right at the middle - for example, they could be one-third to two-fifths of the way down from the top (or up from the bottom).

It should also be noted that the glass 172 of Figure 18 has a mouth 124 that is narrower than a body portion 126. It is believed that having a restricted mouth forms a deeper and longer-lasting head. This may, or
5 may not be associated with the fact that in comparison with the volume of beer associated with the fact that in comparison with the volume of beer contained a glass with a restricted mouth has a smaller exposed surface area of head than if it were in a vessel with straight sides, or outwardly flared sides.

10

Our trials indicate that best/better results can be achieved on pints of beverage than on half-pints of beverage. This may be associated with greater heat capacity of a pint of beverage in comparison with a half-pint of beverage, and the less effect exposure to the environment has/the less
15 rapid the effect of the heat transfer to the local environment, when the ratio of volume of beverage; exposed surface is larger.

Figure 19, illustrates the pint of lager of Figure 18 after about three minutes have expired (or looked at another way after about ten
20 minutes have expired - there is little change in the appearance of the glass of lager between the three minutes and the ten minutes). The head 14 is somewhat deeper than might be expected, and slightly projects above the glass 172. There is a relatively thin layer of ice 188A (of the order of a half to a few millimetres) extending under the head completely across the
25 diameter of the glass 172 and there is a depending projection of flaky ice 188B extending down perhaps two to five centimetres into the cleared beer. The projection 188B may extend for at least three centimetres, five centimetres is not to be taken as necessarily an upper limit to its length. The projection 188B is generally central, but may be off-axis in
30 comparison with the central axis of the glass. It has a narrower tip than it does base (the base being the portion adjacent the head 174).

It will be appreciated that creating a beverage having such an ice formation is in itself new and itself gives a visually differentiated product - which is desirable to consumers.

5

Moreover, creating the bands or stripes during ultrasonic excitation of the glass of beverage also creates a visually distinct product, and a differentiated mode of provision of the product to the consumer.

10 With reference to Figure 20 apparatus to supply cider on draught is indicated at 202.

The draught cider is stored in a keg or cask 204. As stated above, the draught cider has a water content and a dissolved gas content.

15

This gas may be any suitable non-oxidising gas, for example carbon dioxide and/or nitrogen. The amount of gas dissolved in the cider may be within the usual known range for ciders.

20 The dissolved carbon dioxide content may be substantially 1.8% by volume, and/or the dissolved nitrogen content may be substantially 18 parts per million (p.p.m).

A pump 206 is provided to pump cider from the cask 204 through a
25 non-return valve 207 and along a pipe 208 in a chilled python known per se (not shown); the pipe comprising a heat exchange coil 210 in a remote cooling system known per se. The pipe 208 leads to a chilling coil 212 in a bath 214 of a chiller 216, from which coil a pipe 208A leads to a manual valve 218 (known per se) of a dispense outlet or nozzle 220 which
30 may be provided at or on a drinks' bar. Bath 214 contains an ethylene glycol and water cooling mixture 222, for example 50% glycol and 50%

water. The cooling mixture 222 is cooled by an evaporator 224 of a refrigeration unit 226 comprising a condenser 228, a refrigerant pump 230, and an expansion arrangement 232. A pump 234 circulates the cold mixture 222 through piping 236 forming another python 238 with the pipe
5 208A.

In known manner, a blanket or atmosphere of non-oxidising gas (for example carbon dioxide and/or nitrogen) from a suitable supply 240 (via a pressure regulator 242) provides a top pressure in the cask 204 and
10 assists the pump 206 in the extraction of cider.

The top gas pressure in the cask 204 may be substantially 206.84kN/m^2 (30lbs/in^2).

15 The pump 206 may develop a pressure in pipes 208, 208A of substantially 517.12kN/m^2 to substantially 551.58kN/m^2 valve (75 to 80lbs/in^2). Normally pump 206 is not operating, thus when the valve 218 is opened the pump pressure stored in the pipes 208, 208A drops to below a pre-determined desired value which is observed by pressure switch 244
20 of a pump control (not shown) causing the pump 206 to operate to provide a pump output pressure of substantially 75 to 80lbs/in^2 . The chiller 216 is arranged to cool the cider passing through to the outlet nozzle 220 to a pre-determined temperature in the range of substantially -1°C to substantially -12°C , for example -6°C . The cider reaches the nozzle 220
25 at that pre-determined temperature and issues therefrom into an open-topped vessel 46 (Figure 2) which may be a drinking vessel, for example a drinking glass. In Figure 20 the cider issuing from the outlet opening of the outlet nozzle 220 passes through a sparkler 247 (known per se). Instead of or in addition to said sparkler 247, a known orifice plate may

be mounted in nozzle 220. But if desired, neither an orifice plate nor a sparkler may be fitted.

When valve 218 is closed, the pressure switch 244 observes a
5 build-up in pressure in the pipes 208, 208A above a predetermined value and the control switches off the pump 206.

With reference to Fig 21, the draught cider 248 is delivered from the outlet 220 (Figure 20) into the drinking vessel 246, for example a glass which is preferably rather tall and preferably has a clear or
10 transparent wall. Preferably the vessel 246 is chilled before it receives the cider. The vessel 246 may be chilled to a temperature of substantially 4°C or less. For example a known bottle chiller may be used to chill the vessel to substantially 4°C whilst a known glass froster may chill the vessel to substantially 0°C. A head of foam is shown at 250 when the
15 vessel contains a full measured volume, for example a pint, of the cider.

Immediately the cold cider 248 is poured into the chilled vessel 246, the vessel is placed in a shallow depth of water 252 in a dish part 254 of an ultra-sound generating apparatus 256 in which the dish 254 is securely
20 mounted or affixed against a base part 258 containing an ultra-sound emitter 260. The emitter 260 may be arranged to emit ultra-sound signals in a frequency range of substantially 20kHz to 70kHz. For example the cider may be subject to ultra-sound signals of a frequency of substantially 30 kHz or some other frequency selected from the aforesaid range, the
25 water layer 252 providing an ultra-sonic transmission path or coupling. The cider 248 may be subject to the ultra-sound for any desired period, though usually a short period of a few seconds, for example substantially one to five seconds and more specifically about five seconds.

The result in a short time is shown in Figure 22 in which the exposure to ultra-sonic signals has promoted sudden formation of bubbles of dissolved gas throughout the liquid cider 248 some bubbles 252A may be relatively large whilst others 252B may be relatively small and may
5 tend to collect linearly in wavy lines which may snake upwardly. Also the head 250 may rise to increase its height or depth. The gas bubbles form nucleation sites encouraging the quick formation of ice in the cider 248 from water of the water content of the cider. The ice rises. It may be of a slushy character and tends to agglomerate in the lower part of and
10 below the head 250 to form a slushy mass of ice 262 such as indicated in Figure 23 in the cider.

Going from the stage shown in Figure 21 to that in Figure 23 may
15 only take one or two minutes so that the gas bubbling and the formation and visible development of the ice takes place fairly quickly and be interesting phenomena to observe through the glass 246.

Besides the ice forming in the cider 248 being an intriguing sight,
20 it helps show the customer the cider is cold and that it has not been diluted by addition of ice from water other than that already in the cider.

One of the most interesting features is that the head 250 on the glass of cider may last for a considerable time, i.e. several times the
25 duration of a head on cider arising from known methods. The head 250 may last for twenty minutes or so. Its longevity may be due to (i) the mass of ice 262 acting as a seal or barrier to gas attempting to leave the liquid cider body, and/or (ii) the fact that the ice 262 is keeping the head 250 cold.

An alternative method of applying the ultra-sound signals is represented in Figure 24, in which after the apparatus 202 in Figure 20 has dispensed a vessel or glass 246 of cider 248 an ultra-sound probe 264 powered through cable 266 is dipped into the cider for emitter 260A to give out ultra-sound signals. The probe 264 may be inserted into the cider before the full measured amount is supplied to the vessel 246.

In Figure 25, the dispense outlet 220 has been arranged to act as an ultra-sonic probe for example by providing it with an ultra-sonic emitter 260B. The ultra-sonic probe 220 in Figure 25 may emit ultra-sound signals whilst cider is padding through it to the vessel 246, and/or may become partially immersed in the cider as shown and emit ultra-sound signals into the cider 248 in the vessel 246 whilst the measured volume of cider is still being supplied or after it has been supplied.

15

Other features of the matter discussed above form the subject of our co-pending application No. GB 9928225.3 (Serial No. 2 340 924A) from which this application and our co-pending applications Nos. GB 0 027 452.2, GB 0 027454.8 and GB 0 027 457.1 are divided.

20

CLAIMS

1. A beverage in an open-topped vessel, said beverage comprising a water content and a dissolved gas content, and said beverage further
5 comprising ice having a cooling effect on the beverage, said ice being formed in the beverage from water of said water content.
2. A beverage as claimed in Claim 1, in which the beverage has been subjected to the effect of ultrasound signals.
10
3. A beverage as claimed in Claim 2, in which immediately before the draught beverage is delivered into the vessel said beverage is cooled to a temperature below the freezing point of water at ambient atmospheric pressure.
15
4. A beverage as claimed in Claim 3, in which immediately before the draught beverage is delivered into the vessel said beverage is cooled to a temperature below the freezing point of water at ambient atmospheric pressure in a dispensing pipe of a dispensing apparatus.
20
5. A beverage as claimed in Claim 2 or in Claim 3 when appended to Claim 2 or in Claim 4, in which the ultrasound signals are applied externally of said vessel.
- 25 6. A beverage as claimed in Claim 2 or in Claim 3 when appended to Claim 2 or in Claim 4, in which the ultrasound signals are applied internally of said vessel to the cooled beverage.
- 30 7. A beverage as claimed in Claim 6, in which an ultrasound signal emitter is disposed in the beverage in the vessel emitting ultrasound signals into the beverage in the vessel.

8. A beverage as claimed in any one of Claims 5 to 7, in which a dispense outlet or nozzle from which beverage is delivered into said vessel is adapted to act as an ultra-sonic emitter to provide aforesaid
5 ultrasound signals.
9. A beverage as claimed in Claim 8, in which aforesaid ultrasound signals are applied to aforesaid beverage flowing through the dispense outlet.
10
10. A beverage as claimed in Claim 2 or in Claim 3 when appended to Claim 2 or in any one of Claims 4 to 9, in which the ultrasound signals have a frequency in the range of 20kHz to 70kHz.
- 15 11. A beverage as claimed in Claim 10, in which the ultrasound signals have a frequency of substantially 30kHz.
12. A beverage as claimed in any one preceding Claim, in which a mass of said ice develops from an upper level of the beverage downwards
20 in the beverage.
13. A beverage as claimed in any one preceding Claim, in which the vessel is chilled before beverage is delivered thereinto.
- 25 14. A beverage as claimed in Claim 13, in which the vessel is chilled to a temperature of substantially 4°C, or the vessel is chilled to a temperature less than 4°C.
15. A beverage as claimed in Claim 13, in which the vessel is chilled
30 to a temperature of substantially 0°C.

16. A beverage as claimed in Claim 3 or Claim 4 or in any one of Claims 5 to 15 when appended to Claim 5, in which the beverage is cooled to a temperature between substantially -1°C and substantially -12°C .

5

17. A beverage as claimed in Claim 16, in which the beverage is cooled to a temperature between substantially -4°C and substantially -6°C .

18. A beverage as claimed in any one preceding Claim, in which the vessel is a glass drinking vessel.

10

19. A beverage as claimed in any one preceding Claim, in which comprises a dissolved gas which comprises carbon dioxide and/or comprises nitrogen.

15

20. A beverage as claimed in Claim 19, in which the dissolved nitrogen content in the beverage is in the range of substantially zero parts per million (p.p.m.) to substantially 100 parts p.p.m.

21. A beverage as claimed in claim 19 or in Claim 20, in which the dissolved carbon dioxide content is about zero % by volume or greater.

20

22. A beverage as claimed in Claim 21, in which the carbon dioxide is substantially 2.2% or substantially 4% or substantially 5% by volume.

25

23. A beverage as claimed in any one preceding Claim, in which the vessel has a shape or formation to promote formation of said ice.

24. A beverage as claimed in Claim 23, in which the vessel has an internal surface arranged to provide nucleation sites to promote formation of said ice.

30

25. A beverage as claimed in Claim 24, in which said surface has at least a surface portion which is roughened.
- 5 26. A beverage as claimed in any one preceding Claim, in which the vessel has at least a wall portion arranged to change colour automatically with variations in temperature.
- 10 27. A beverage as claimed in Claim 26, in which said wall portion comprises thermo-chromic material.
- 15 28. A beverage as claimed in any one preceding of Claim, in which an implement is inserted into the beverage in the vessel to encourage formation of said ice.
- 20 29. A beverage as claimed in Claim 28, in which said implement is a thermometer.
30. A beverage as claimed in Claim 28, in which said implement is a swizzle-stick.
31. A beverage as claimed in any one preceding Claim, in which said alcoholic beverage is a beer.
- 25 32. A beverage as claimed in Claim 31, in which said beer is a lager.
33. A beverage as claimed in any one of Claims 1 to 30 in which said beverage is a cider.
- 30 34. A beverage as claimed in any one preceding Claim, in which said ice comprises slush.

35. A beverage as substantially as described herein with reference to the accompanying figures.



INVESTOR IN PEOPLE

Application No: GB 0126685.7
Claims searched: 1-35

38

Examiner: Kalim Yasseen
Date of search: 12 February 2002

Patents Act 1977 Search Report under Section 17

Databases searched:

UK Patent Office collections, including GB, EP, WO & US patent specifications, in:
UK Cl (Ed.T): A2B (BMH19); F4H (H2K)
Int Cl (Ed.7): B67D (1/04, 1/06, 1/08, 1/14, 5/62); C12H (1/18); F25D (17/02)
Other: Online: EPODOC, JAPIO, WPI

Documents considered to be relevant:

Category	Identity of document and relevant passage	Relevant to claims
X	US 3 826 829 A (MARULICH) a beverage comprising a water content and a dissolved gas content, the water turning into ice when cooled overnight in the refrigerator, see whole document especially column 4 lines 1-62	1
X	Online (WPI) abstract for JP460010033 B (MORINAGA) a carbonated drink which forms ice on uncovering the container	1, 18, 19, 21

X	Document indicating lack of novelty or inventive step	A	Document indicating technological background and/or state of the art.
Y	Document indicating lack of inventive step if combined with one or more other documents of same category.	P	Document published on or after the declared priority date but before the filing date of this invention.
&	Member of the same patent family	E	Patent document published on or after, but with priority date earlier than, the filing date of this application.