

(19) World Intellectual Property Organization  
International Bureau



(43) International Publication Date  
30 November 2000 (30.11.2000)

PCT

(10) International Publication Number  
WO 00/71045 A1

(51) International Patent Classification<sup>7</sup>: A61B 18/20

(21) International Application Number: PCT/IL99/00279

(22) International Filing Date: 25 May 1999 (25.05.1999)

(25) Filing Language: English

(26) Publication Language: English

(71) Applicant and

(72) Inventor: SHARON, Uzi [IL/IL]; 30a Ugarit Street, Tel-Aviv 69016 (IL).

(74) Agents: FENSTER, Paul et al.; Fenster & Company Patent Attorneys, Ltd., P.O. Box 10256, Petach Tikva 49002 (IL).

(81) Designated States (national): AE, AL, AM, AT, AU, AZ, BA, BB, BG, BR, BY, CA, CH, CN, CU, CZ, DE, DK, EE,

ES, FI, GB, GD, GE, GH, GM, HR, HU, ID, IL, IN, IS, JP, KE, KG, KP, KR, KZ, LC, LK, LR, LS, LT, LU, LV, MD, MG, MK, MN, MW, MX, NO, NZ, PL, PT, RO, RU, SD, SE, SG, SI, SK, SL, TJ, TM, TR, TT, UA, UG, US, UZ, VN, YU, ZA, ZW.

(84) Designated States (regional): ARIPO patent (GH, GM, KE, LS, MW, SD, SL, SZ, UG, ZW), Eurasian patent (AM, AZ, BY, KG, KZ, MD, RU, TJ, TM), European patent (AT, BE, CH, CY, DE, DK, ES, FI, FR, GB, GR, IE, IT, LU, MC, NL, PT, SE), OAPI patent (BF, BJ, CF, CG, CI, CM, GA, GN, GW, ML, MR, NE, SN, TD, TG).

Published:  
— With international search report.

For two-letter codes and other abbreviations, refer to the "Guidance Notes on Codes and Abbreviations" appearing at the beginning of each regular issue of the PCT Gazette.

(54) Title: LASER FOR SKIN TREATMENT

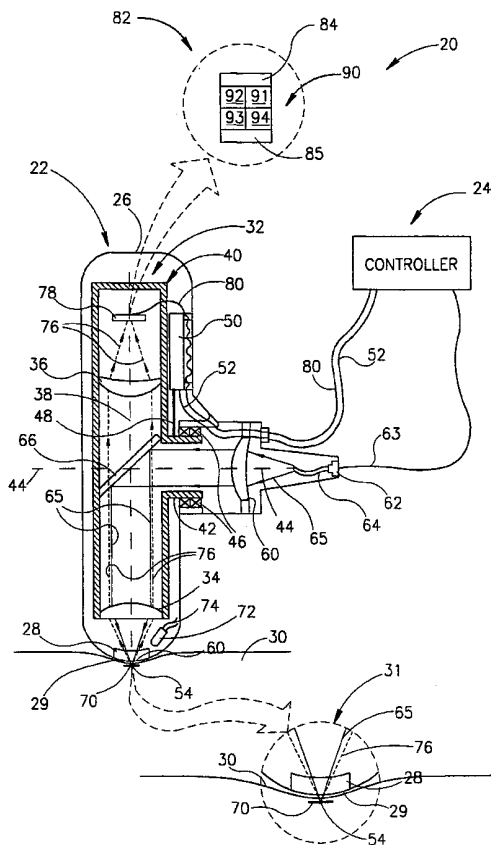

(57) Abstract: A laser system for treating features on the skin of a patient with laser light comprising: an imaging subsystem that locates features on the skin to be treated; a laser; laser optics that focuses light from the laser onto a feature located by the imaging subsystem; and a controller that when a feature is located, controls the laser to radiate a pulse of laser light that is focused by the laser optics to a spot localized about the feature.



WO 00/71045 A1

**LASER FOR SKIN TREATMENT****FIELD OF THE INVENTION**

The invention relates to laser devices and especially to laser devices used for cosmetic and surgical treatment of the skin.

5

**BACKGROUND OF THE INVENTION**

The use of lasers in corrective and cosmetic surgery procedures is well known. In these procedures light from a laser comprised in an appropriate mechanical-optical system causes a desired cosmetic or surgical change in a region of tissue by delivering to the region an amount of energy sufficient to effect the change. A common problem often encountered in these  
10 procedures is to deliver the energy to the region, hereinafter referred to as a "target", without delivering energy to tissue surrounding the region that might damage the surrounding tissue. Many prior art medical laser systems do not solve this problem satisfactorily and often deliver substantial amounts of unwanted and unneeded energy to tissue surrounding a target that they irradiate.

15

For example, laser light is often used to depilate skin by cauterizing follicles of hair to be removed from the skin. Most prior art laser depilators irradiate areas of skin much larger than the area of skin occupied by a hair follicle. As a result, most of the laser energy these depilators radiate is wasted. A major portion of the laser energy is incident on hairless areas of skin and only a small portion is incident on targets (*i.e.* hair follicles) on the skin and used to  
20 remove hair. Since the prior art laser depilators are energy inefficient, they generally require relatively powerful lasers that illuminate skin being treated with a high energy density of laser light. This energy density when incident on hairless regions of skin can cause thermal damage to these areas.

25

For example, typically 20 milliJoules (mJ) of energy are required to cauterize a hair follicle and a typical hair follicle occupies an area of skin approximately  $3 \times 10^{-4} \text{ cm}^2$ . An energy density of about  $60 \text{ J/cm}^2$  therefore is generally required to cauterize hair follicles. Many prior art laser depilators irradiate an area of skin on the order of  $1 \text{ cm}^2$  with a pulse of laser energy lasting about a millisecond or a fraction of a millisecond to depilate an area of skin. A Laser in one of these systems must therefore provide a peak power output of about  
30 60,000 watts.

**SUMMARY OF THE INVENTION**

An aspect of some preferred embodiments of the present invention relates to providing a laser system for medical/cosmetic treatment of skin, such as for hair removal, coagulation of

varicose veins and the removal of skin tumors, that minimizes the amount of laser energy incident on tissue surrounding targets that the system irradiates.

According to an aspect of some preferred embodiments of the present invention, the laser system comprises an optical imaging subsystem that scans the skin of a patient being treated and identifies and locates targets for treatment in the area.

Preferably, the optical imaging subsystem comprises a microscope that collects light from an object that it images and focuses the collected light to form a magnified image of the object on a photosensitive surface. The skin being treated is optically scanned by positioning the microscope's objective lens close to the skin and moving the microscope so as to image different regions of the skin onto the photosensitive surface. Image data from the photosensitive surface characteristic of an imaged region are transmitted to circuitry that analyzes the data to determine if a target is located in the imaged region. Preferably, an imaged region is determined to have a target if a portion of the image exhibits characteristics typical of a target and the portion corresponds to an area of the skin substantially centered at the focal point of the microscope.

Preferably, the laser system comprises a light source that illuminates regions of the skin imaged by the microscope with light having a spectrum that enhances the contrast between targets and clear skin devoid of targets.

For example, assume that the skin is being depilated, that targets on the skin to be searched for are hair follicles and that the skin is illuminated with light for which hair follicles have relatively low reflectance compared to the reflectance of clear skin. Since the hair follicles are expected to reflect less light than clear skin, the imaging subsystem will search for relatively dark areas on the skin having a size characteristic of hair follicles. If such a relatively dark area is found in an imaged region of the skin and the dark area is substantially centered at the focal point of the microscope, the imaged region is determined to have a target for irradiation.

According to an aspect of some preferred embodiments of the present invention the laser system comprises a laser and associated optical elements that are controllable to irradiate with laser energy substantially only targets identified by the imaging subsystem.

The optical elements preferably focus light from the laser to a spot centered at the focal point of the microscope. The spot size is preferably determined with reference to the sizes of targets to be treated with the system. Preferably, the spot size is determined to be a small multiple of an expected characteristic size of the targets. In some preferred embodiments of the

present invention it is less than three times the size of the feature. Preferably, the spot size is smaller than twice the characteristic size of the feature. More preferably the spot size is less than 1.5 times the characteristic size of the feature. Most preferably, the spot size is greater than about 1.2 times the characteristic size of the feature. For example, if the laser system is being used to depilate skin, the spot size is preferably determined to be a small multiple of a characteristic size of a hair follicle. A characteristic size of a hair follicle might be an average size of a hair follicle or a hair follicle size that is greater than the size of 95% of the hair follicles. If the laser unit is being used to eradicate small tumors, a characteristic size is a suitable expected size of the tumors.

10 The laser is preferably turned on and off by a controller. During the scan of a treated area of skin the laser is normally off. However, when an imaged region of the skin is determined to have a target located within a "spot size" of the microscope's focal point, the controller turns the laser on to deliver a pulse of laser light to a spot centered at the focal point and thereby to the target. Preferably, the controller determines the energy in the pulse by  
15 controlling the pulse width and/or the intensity of light in the light pulse.

The scan speed of the imaging subsystem is preferably sufficiently slow so that the imaging system remains focused substantially on a same region of skin during the time it takes to determine whether an imaged region has a target and energize the laser. Furthermore, as noted above, the spot size to which a light pulse is focused, is preferably slightly larger than a  
20 target defined by a feature of the skin that is to be irradiated. Therefore, the energy in laser light pulses radiated by the laser system is substantially restricted to areas of targets or areas immediately surrounding targets. For example the energy in a laser light pulse might be restricted to an area having a diameter 1.5 or 2 times the diameter of the area of a target that the light pulse irradiates.

25 Thus, with a laser system in accordance with a preferred embodiment of the present invention, laser energy used to effect cosmetic or surgical changes in the skin of a patient is substantially restricted to only those areas of the skin that require treatment. Little of the energy radiated by the system is incident on skin areas where it is not needed.

A laser system in accordance with a preferred embodiment of the present invention  
30 therefore uses laser energy efficiently and can generally treat features on a patient's skin using a laser having substantially lower power output than lasers used in comparative prior art systems. For example in a laser depilator, in accordance with a preferred embodiment of the present invention, laser energy is focused to a spot size of about  $3 \times 10^{-4}$  cm<sup>2</sup>. Laser energy is

delivered to cauterize a hair follicle in a laser pulse having a pulse width of about 2 milliseconds. Assuming 20 mJ of energy is needed to cauterize the hair follicle a laser that provides the pulse has to supply a peak power of about 10 watts. The laser depilator, in accordance with a preferred embodiment of the present invention, uses a laser having a peak power output about one thousandth that used in many prior art laser depilators.

Whereas in the example given above a laser providing a peak power of ten watts is used, a laser that provides different peak power output is useable in a laser system in accordance with a preferred embodiment of the present invention. Preferably the peak power of the laser is less than 100 watts. More preferably the peak power is less than 50 watts. Most preferably the peak power is less than 30 watts.

According to an aspect of some preferred embodiments of the present invention the microscope, photosensitive surface and laser are mounted in a hand unit. To treat a patient an operator of the laser system holds the hand unit with the microscope objective lens close to and facing the patient's skin. The operator moves the hand unit substantially parallel to the skin to scan an area of the skin for targets. As targets are identified, they are irradiated with laser light from the laser.

In accordance with an aspect of some preferred embodiments of the present invention the microscope is preferably mounted in the hand unit so that it is rotatable about an axis of rotation that is perpendicular to the microscope's optic axis and fixed with respect to the hand unit. The microscope is coupled to a motor or actuator in the hand unit that rotates the microscope about the axis back and forth through a predetermined angle. The focal point of the microscope therefore moves back and forth, near to or on the surface of the patient's skin, along a direction perpendicular to the axis of rotation of the microscope. The operator preferably moves the hand unit along the skin in a direction substantially parallel to the axis of rotation. As a result of the back and forth motion of the focal point of the microscope and the motion of the hand unit, the imaging system scans a ribbon shaped area on the patient's skin and target regions in the area are identified and irradiated.

There is thus provided, in accordance with a preferred embodiment of the invention, a laser system for treating features on the skin of a patient with laser light comprising:

- an imaging subsystem that locates features on the skin to be treated;
- a laser;
- laser optics that focuses light from the laser onto a feature located by the imaging subsystem; and

a controller, that when a feature is located, controls the laser to radiate a pulse of laser light that is focused by the laser optics to a spot localized about the feature.

Preferably, the system includes a light source that illuminates regions imaged by the imaging optics with light for which the features to be treated have a reflectance different from that of clear skin so that a feature to be treated appears as a contrasted sub-region of an imaged region of the skin.

Preferably, the spectrum of the light radiated by the light source is tunable.

Preferably, the spot to which the laser is focused has an area substantially equal to an area characteristic of the size distribution of areas occupied on the skin by features to be treated, multiplied by a factor greater than one. Preferably, the factor is less than 2 or 1.5. Preferably, the factor is greater than about 1.2.

Preferably, the controller controls the laser to radiate a pulse of light only if a located feature occupies an area on the skin consistent with the size distribution of areas occupied on the skin by features to be treated.

In a preferred embodiment of the invention, the imaging subsystem scans an area of the skin and during scanning automatically locates features on the area to be treated.

In a preferred embodiment of the invention, the imaging subsystem comprises:

at least one photosensitive surface that generates signals responsive to an image formed thereon; and

imaging optics that images light that it collects on the at least one photosensitive surface;

wherein, to scan the area, the imaging optics are moved relative to the skin so as to image regions in the scanned area onto the at least one photosensitive surface.

Preferably, the imaging optics has a focal point and the spot to which the pulse of laser light is focused is centered at the imaging optics focal point.

Preferably, the controller controls the laser to radiate a pulse of light only if a feature to be treated is determined to lie substantially within an area centered at the imaging optics focal point having a size substantially equal to the size of the spot to which the laser pulse is focused.

Preferably, the system includes circuitry that receives signals generated by the at least one photosurface responsive to an imaged region of the skin and processes the signals to locate contrasted sub-regions in the imaged region to locate features to be treated.

Preferably, the at least one photosensitive surface comprises a single photosensitive surface. Preferably, the photosensitive surface comprises a quadrature detector. Preferably

signals from the quadrature detector are used to determine whether a contrasted sub-region imaged on the quadrature detector is substantially centered within the spot to which the laser pulse is focused. Preferably, signals from the quadrature detector are used to determine whether a contrasted sub-region imaged on the quadrature detector is larger than a predetermined minimum size consistent with the size distribution of areas occupied on the skin by features to be treated.

In a preferred embodiment of the invention, the photosensitive surface additionally comprises at least two photodetectors located adjacent to opposite sides of the quadrature detector. Preferably, if any of the photodetectors adjacent to sides of the quadrature detector generates a signal responsive to a contrasted sub-region imaged on the photosensitive surface, a portion of the sub-region is determined to lie outside the spot to which the laser pulse is focused and the laser is not energized.

In an alternative preferred embodiment of the invention, the at least one photosurface comprises a first and a second photosensitive surface. Preferably, the first photosensitive surfaces comprises a quadrature detector. Preferably, signals from the quadrature detector are used to determine whether a contrasted sub-region imaged on the quadrature detector is substantially centered within the spot to which the laser pulse is focused. Preferably, signals from the quadrature detector are used to determine whether a contrasted sub-region imaged on the quadrature detector is larger than a predetermined minimum size consistent with the size distribution of areas occupied on the skin by features to be treated.

In a preferred embodiment of the invention, the second detector comprises a photodetector having a mask that blocks light from impinging on an area located at its center. Preferably, the photosensitive surface generates signals responsive to a contrasted sub-region imaged on the photosensitive surface, a portion of the sub-region is determined to lie outside of the spot to which the laser pulse is focused and the laser is not energized.

In a preferred embodiment of the invention, the imaging optics comprises an objective lens system having a focal point that collects light from regions imaged by the imaging subsystem and wherein the focal point of the imaging optics is the focal point of the objective lens system. Preferably, the laser optics comprises an ocular lens system that receives light collected by the objective lens system and images the received light on the at least one photosensitive surface. Preferably, the objective lens system is rotatable about an axis of rotation that intersects the optic axis of the objective lens system. Preferably, the laser optics comprises a collimating lens system that receives light radiated by the laser, which it collimates

and transmits parallel to the axis of rotation. Preferably, the imaging optics comprises a reflector that reflects the collimated laser light towards the objective lens system along a direction parallel to the optic axis of the objective lens system so that the laser light is focused to a spot at the focal point of the objective lens system.

5 In a preferred embodiment of the invention, the reflector is a beam splitter. Preferably, the ocular lens system and the at least one photosensitive surface are positioned on a side of the reflector opposite to the side of the reflector on which the objective lens system is located.

In an alternative preferred embodiment of the invention, the reflector is a mirror. Preferably, the ocular optics and the at least one photosensitive surface are stationary with  
10 respect to the axis of rotation. Preferably, the system a beam splitter positioned between the collimating lens and the mirror and wherein light collected by the objective optics is reflected by the mirror along the axis of rotation towards the beam splitter, which reflects some of the collected light incident on it towards the ocular lens system.

In a preferred embodiment of the invention, the system comprises a motor or actuator  
15 that is coupled to the objective lens system and rotates the objective lens system with an oscillatory motion about the axis of rotation, so that the objective focal point moves back and forth along a planar arc having a fixed length.

In a preferred embodiment of the invention, the imaging optics and the at least one photosensitive surface are mounted within a hand held unit. Preferably, the light source is  
20 mounted in or on the hand held unit. Preferably, the laser is mounted within the hand held unit. Preferably, the controller is mounted in the hand held unit. Preferably, the system comprises a power source mounted in the hand held unit.

There is further provided, in accordance with a preferred embodiment of the invention, a method for treating features on the skin of a patient with laser light comprising:

25 optically scanning the patient's skin to locate features to be treated; and  
during scanning, when a feature is located, focusing a pulse of laser light energy to a spot that covers substantially completely the feature, which spot has an area substantially equal to an area characteristic of the size distribution of areas occupied on the skin by features to be treated, multiplied by a factor greater than one, preferably, greater than about 1.2 and  
30 preferably less than about 1.5 or 2.

In a preferred embodiment of the invention, the method includes analyzing imaged regions of the skin to locate features to be treated. Preferably, analyzing imaged regions comprises determining whether an imaged region of the skin has a feature having a size



consistent with the size distribution of areas occupied on the skin by features to be treated. Preferably, analyzing imaged regions comprises determining whether an imaged region of the skin has a hair feature to be treated located within a localized region on the skin which is centered at the focal point.

5           There is further provided, in accordance with a preferred embodiment of the invention, a method for depilating a patient's skin using laser light comprising:

          optically scanning the patient's skin to locate hair follicles in regions of the skin to be depilated; and

          during scanning, when a hair follicle is located, cauterizing the hair follicle by focusing  
10 a pulse of laser light energy to a spot that shadows substantially completely the hair follicle, which spot has an area substantially equal to an area characteristic of the size distribution of areas occupied on the skin by hair follicles, multiplied by a factor greater than one, preferably greater than about 1.2, and preferably less than 1.5 or 2.

          In a preferred embodiment of the invention, the method includes analyzing imaged  
15 regions of the skin to locate hair follicles to be treated. Preferably, analyzing imaged regions comprises determining whether an imaged region of the skin has a feature having a size consistent with the size distribution of follicles areas occupied on the skin by features to be treated. Preferably, analyzing imaged regions comprises determining whether an imaged region of the skin has a follicle to be treated located within a localized region on the skin which is  
20 centered at the focal point.

          In a preferred embodiment of the invention, scanning comprises moving an optical imaging system having a focal point over the patients skin to image different regions of the skin. Preferably, moving an optical imaging system comprises moving the focal point close to and along the patient's skin.

25           Preferably, focusing a pulse of laser light energy comprises focusing the energy to a spot centered at the focal point.

          In a preferred embodiment of the invention, the localized region is substantially equal to the size of the spot to which the laser light is focused. Preferably, moving the focal point comprises moving the focal point with an oscillatory motion along a first direction on the skin.  
30 Preferably, the method includes moving the focal point in a second direction substantially perpendicular to the first direction while the focal point is oscillating. Preferably, moving the optical imaging system comprises moving the optical imaging system by hand.

## BRIEF DESCRIPTION OF FIGURES

The invention will be more clearly understood by reference to the following description of preferred embodiments thereof read in conjunction with the figures attached hereto. In the figures identical structures, elements or parts which appear in more than one figure are labeled with the same numeral in all the figures in which they appear. Dimensions of components and features shown in the figures are chosen for convenience and clarity of presentation and are not necessarily shown to scale. The figures are listed below.

Fig. 1A shows schematically a laser system comprising a hand unit shown in cut-away side view, in accordance with a preferred embodiment of the present invention;

Fig. 1B shows a schematic circuit for analyzing images of regions of a patient's skin formed on a photosensitive surface located in the hand unit shown in Fig. 1A, in accordance with a preferred embodiment of the present invention;

Fig. 2 shows schematically the hand unit shown in Fig. 1A in a cut-away front view;

Fig. 3 shows schematically the laser system being used to remove hair from the arm of a patient, in accordance with a preferred embodiment of the present invention; and

Fig. 4 shows schematically a variation of the hand unit shown in Figs. 1 - 3, in accordance with a preferred embodiment of the present invention.

## DETAILED DESCRIPTION OF PREFERRED EMBODIMENTS

Fig. 1A schematically shows a laser system 20, in accordance with a preferred embodiment of the present invention, comprising a hand unit 22 and a controller 24. Hand unit 22 is shown in a cutaway cross-section view. It should be noted that whereas controller 24 is shown separate from hand unit 22, in most preferred embodiments, controller 24 is mounted on or inside hand unit 22. In addition, energy to power hand unit 22 may come from an external power supply or preferably from an appropriate portable power supply mounted inside hand unit 22.

Hand unit 20 preferably comprises a housing 26 having a window 28. Window 28 has a surface 29 that is pressed to the skin 30 of a patient. Surface 29 and skin 30 are shown separated by a small distance for clarity of presentation and are shown magnified in an insert 31. Hand unit 20 comprises a microscope 32 mounted inside housing 26. Microscope 32 comprises an objective lens 34, an ocular lens 36 and an optic axis 38. Objective lens 34 and ocular lens 36 are preferably mounted in a microscope housing 40. Whereas microscope 32 is shown comprising only two lenses, a hand unit in accordance with a preferred embodiment

may comprise a microscope having more than two lenses. For example, the ocular and/or the objective may comprise a system of lenses.

Microscope housing 40 preferably has a circularly cylindrical tubular extension 42 having an axis of rotation 44 that preferably intersects optic axis 38 at 90°. Microscope 32 is preferably rotatably mounted to hand unit 22 by mounting tubular extension 42 to a bearing 46 that is fastened to housing 26 of hand unit 22. Bearing 46 preferably enables microscope 32 to be rotated back and forth about axis of rotation 44 but prevents motion of microscope 32 parallel to axis of rotation 44. Preferably microscope 32 is controlled to rotate back and forth about axis 44 with an oscillating motion having predetermined angular amplitude. Preferably the frequency of oscillation is less than 100 HZ. More preferably, the frequency of oscillation is less than 50 Hz. Most preferably the frequency is between 5 and 20 Hz.

Many methods for achieving the oscillatory motion are known in the art and may be used in accordance with preferred embodiments of the present invention for providing such motion to microscope 32. For example, in some preferred embodiments of the present invention a electromotor or piezoelectric micromotor is pressed to the surface of tubular extension 42, and thereby microscope 32, to rotate tubular extension 42 back and forth about axis of rotation 44. In some preferred embodiments of the present invention tubular extension 42 is coupled by an appropriate mechanical drive train to a motor or actuator that rotates tubular extension 42 in an oscillatory motion.

By way of example, in Fig. 1A tubular extension 42 is shown having an arm 48 that is rotated back and forth by a motor 50 in order to oscillate microscope 32. Arm 48 is mechanically coupled to motor 50, using any of many various mechanical configurations (not shown) known in the art, such as a by a crank and crankshaft. Preferably motor 50 is controlled and powered by controller 24 to which motor 50 is connected by an appropriate power and control line 52.

The size of window 28, its relative position with respect to microscope 32 and the amplitude of motion of microscope 32 are preferably such that for each angular position of microscope 32 about axis 44, optic axis 38 passes through window 28. Microscope 32 has a focal point 54, preferably located a short distance below window 28. Focal point 54 is most clearly shown in insert 31. As a result of the oscillating motion of microscope 32, focal point 54 moves back and forth along a circular arc (not shown), which is perpendicular to the plane of Fig. 1A and which lies in a plane perpendicular to axis 44. The projection of focal point 54 on skin 30 oscillates back and forth and scans skin 30 along a substantially straight line

perpendicular to the plane of Fig. 1A (and of course axis 44). Preferably, surface 29 of window 28 is curved in the plane of the arc of motion of focal point 54 so that focal point 54 is substantially a same distance from surface 29 for all points along its arc of motion.

5 Hand unit 22 preferably comprises a laser 62 and a collimating lens 60 having an optic axis coincident with axis of rotation 44. Laser 62 is turned on and off by controller 24 to which laser 62 is connected via a control line 63. Laser light from laser 62 is preferably piped to collimating lens 60 via a light guide 64. The laser light is represented by lines 65 that have arrows indicating the direction of travel of the laser light. Collimating lens 60 collimates laser light 65 and directs the collimated laser light to a beam splitting mirror 66 located between  
10 objective and ocular lenses 34 and 36. Beam splitter 66 directs some of laser light 65 in a direction parallel to optic axis 38 towards objective lens 34, which focuses laser light 65 to a spot 70 (shown in cross section) centered on focal point 54. Spot 70 and its relationship to focal point 54 is most clearly shown in insert 31.

15 Preferably laser 62 is a laser diode or an array of a plurality of laser diodes. Light guide 64 preferably comprises a fiber optic bundle. Preferably, laser 62 and light guide 64 are matched so that their throughput is such that spot 70 has a size slightly larger than a characteristic size of a target being treated with laser system 20. (The throughput of the combination of laser 62 and light guide 64 is the product of the cross sectional area of light guide 64 and the angular divergence of laser light exiting the output end of light guide 64.) For  
20 example, assume that laser system 20 is being used to remove hair from skin 30 by cauterizing hair follicles with laser energy. Hair follicles have an average diameter of about 200 microns. Therefore, the throughput of laser 62 and light guide 64 is preferably determined so that spot size 70 has a diameter of about 250 microns. This choice for spot size assures efficient cauterization of hair follicles having a diameter of 200 microns without irradiation of large  
25 areas of skin 30 surrounding hair follicles that are cauterized.

Hand unit 22 preferably comprises a light source 72 that radiates light through window 28 to illuminate regions of skin 30 located in the vicinity of focal point 54. In some preferred embodiments of the present invention light source 72 comprises a LED or a low powered laser having a spectrum that enhances contrast between features to be irradiated and clear skin.

30 Preferably, light source 72 comprises a white light source (not shown) that radiates white light onto a preferably adjustable spectrometer (not shown). The adjustable spectrometer, comprising an appropriate diffraction grating or prism, determines the spectral distribution of light from the white light source that is radiated by light source 72 to illuminate skin 30. Light

source 72 is preferably connected to controller 24 by an appropriate control line 74 (only part of which is shown). Preferably, controller 24 controls the spectrometer so that light source 72 radiates light through window 28 that has a spectral distribution which enhances contrast between features of skin 30 to be treated and skin tissue that is free of the features to be treated.

5 For example, if skin 30 is to be depilated, preferably skin 30 is first shaved and light source 72 is controlled to illuminate skin 30 with light having a spectral distribution that enhances the contrast between hair follicles of the shaved hairs and hairless skin.

Objective lens 34 collects light from light source 72 that is reflected by a region of skin 32 substantially centered at focal point 54 and directs the collected light, towards ocular lens 10 36. The reflected light is represented by dashed lines 76, which have arrows to indicate the direction of travel of the reflected light. Some of light 76 is transmitted by beam splitter 66 to ocular lens 36, which focuses light 74 to form an image of the region on a photosensitive surface 78.

Photosensitive surface 78 generates signals responsive to the image and the signals are 15 preferably transmitted to controller 24 via a data line 80. Controller 24 comprises circuitry that analyzes the signals to determine if a feature to be treated with laser light is imaged on photosensitive surface 78. If such a feature is found and is localized within an area centered on focal point 54 that has a size substantially equal to the size of spot 70, the region is determined to have a target. For example, if hair follicles are being treated, controller 24 "searches" for a 20 localized dark or light (depending upon the spectrum of light from light source 72) area set against a bright or dark background respectively that has a size characteristic of a hair follicle. If such an area is found and it is substantially localized within an area centered at focal point 54 having the size and shape of spot 70 it is determined to be a target.

Different types of photosensitive surfaces known in the art are useable as photosensitive 25 surface 78. For example, in some preferred embodiments of the present invention photosensitive surface 78 comprises a pixelated photosensitive surface such as a CCD camera. In these embodiments a relatively detailed image of a region centered on the focal point is acquired and analyzed. In other more preferred embodiments of the present invention photosensitive surface 78 comprises a relatively small number of photodetectors in an array 30 appropriate for determining whether a feature is a target or not.

A version of photosensitive surface 78 based on quadrature detection is shown in insert 82. Photosensitive surface 78 preferably comprises photodetectors 84 and 85 and a quadrature detector 90 comprising photodetectors 91, 92, 93 and 94 and having a center point. Axis 38

intersects photosensitive surface 78 at its center point. When a feature that might represent a feature to be treated with laser light is imaged on photosensitive surface 78, signals from photodetectors 91, 92, 93 and 94 are processed using algorithms known in the art to estimate the location of the feature with respect to focal point 54. Signals from photodetectors 84 and 85 are used to determine if the imaged feature occupies an area on the skin greater than a predetermined maximum area. If the image of the feature on photosensitive surface 78 simultaneously stimulates either of photodetectors 84 and 85, the feature is determined by controller 24 to be outside the area of quadrature detector 90 or have an area greater than the maximum area. If the feature is determined to be smaller than the maximum area (*i.e.* neither of photodetectors 84 and 85 is stimulated) and its centroid is determined to be within a predetermined maximum distance from focal point 54, then the feature is a target to be irradiated with laser light. The maximum area and maximum distance are preferably chosen to assure that the feature lies substantially within an area centered at focal point 54 whose size is substantially equal to the size of spot 70. Once a target is determined to be imaged on photosensitive surface 78, controller 24 controls laser 62 to radiate a pulse of light that is focused to spot 70 and deposits a desired amount of energy on the target.

Fig. 1B shows a schematic circuit 240 that illustrates how signals from photosurface 78 shown in insert 82 are used to determine whether or not to energize laser 62.

Let  $S_{84}$ ,  $S_{85}$ ,  $S_{91}$ ,  $S_{92}$ ,  $S_{93}$ , and  $S_{94}$  represent signals received from detectors 84, 85, 91, 92, 93 and 94 respectively. Define a sum signal  $Z = (S_{91} + S_{92} + S_{93} + S_{94})$ . The magnitude of  $Z$  is a measure of the total amount of light received by photosensitive surface 78 from a feature imaged on photosensitive surface 78. Sum signal  $Z$  is used to determine whether or not a prospective feature for treatment is imaged on photosensitive surface 78 and to normalize signals from the individual detectors 91 - 94. In order to energize laser 62 the sum signal  $Z$  must be larger than a predetermined threshold, *i.e.* there must be a feature to be treated imaged on photosensitive surface 78 and the feature must be larger than a predetermined size as determined by the threshold.

Define  $S_X = |(S_{91} + S_{94}) - (S_{92} + S_{93})|/Z$  and  $S_Y = |(S_{91} + S_{92}) - (S_{93} + S_{94})|/Z$ . The magnitudes of  $S_X$  and  $S_Y$  indicate respectively how far off center the centroid of the imaged feature is from focal point 54 along two orthogonal "X" and "Y" directions. For a feature whose centroid is substantially located at focal point 54,  $S_X$  and  $S_Y$  are substantially equal to zero.

Circuit 240 comprises two comparators 242 and 244 for comparing  $S_X$  and  $S_Y$  to a voltage  $V_B$ . Signals  $S_X$  and  $S_Y$  are input to the plus inputs of comparators 242 and 244 respectively. Comparators 242 and 244 generate output signals only if  $S_X$  and  $S_Y$  respectively are greater than the bias voltage  $V_B$ .

5           The outputs of comparators 242 and 244 are input to a four way OR circuit 246. Signals S84 and S85 are also input to OR circuit 246. OR circuit 246 generates an output signal if either S84 or S85 is non-zero or if there is a signal from either comparator 242 or 244. The output of OR circuit 246 is input to AND circuit 248 after being inverted.

10           Sum signal Z is input to a comparator 250 that compares sum signal Z to a threshold voltage  $V_T$ . The output of comparator 250 is input to AND circuit 248. AND circuit 248 receives a signal from comparator 250 only if the sum signal Z is larger than  $V_T$ .

15           AND circuit 248 therefore generates a signal only if a feature of sufficient size is imaged on photosensitive surface 78, as indicated by sum signal Z, and only if there are no signals from detector 84 detector 85, comparator 242 and comparator 244. If there is an output signal from AND circuit 248 laser 62 is energized.

20           It is seen that  $V_B$  determines upper limits in the X and Y directions for the displacement of the centroid of a feature imaged on photosensitive surface 78. If  $S_X$  and  $S_Y$  are greater than  $V_B$ , the imaged feature is determined to be too far off center or too large to be an acceptable target for irradiation with laser light and AND circuit 248 will not generate an output signal.

          It should be noted that circuit 240 assumes that a feature to be irradiated is brighter than background skin. A similar circuit (in which for example  $S_X$ ,  $S_Y$ , S84 and S85 are inverted) is used for processing images from photosensitive surface 78 if a feature to be irradiated is darker than the background skin.

25           Preferably, hand unit 22 comprises sensors (not shown) that detect whether or not window 28 is pressed to a patient's skin. Preferably, the sensors are pressure sensors that provide output signals responsive to pressure on window 28. Preferably, laser 62 is energized only if the output signals indicate that window 28 is being pressed to a patient's skin.

30           Preferably, circuitry that analyzes signals from photosensitive surface 78 to "acquire a target" and energize laser 62 performs these tasks in a time that is short compared to a "spot crossing time" *i.e.* the diameter of spot 70 divided by the scanning speed of focal point 54. As a result, signal analysis and target acquisition is performed, in accordance with a preferred embodiment of the present invention, continuously, substantially in real time.

Assume that microscope 32 oscillates with a frequency of 20 cps and that the amplitude of motion of focal point 54 is 2.5 cm. Focal point 54 therefore scans the skin with a velocity of 100 cm/s. If the size of spot 70 is 200 microns then the spot crossing time is  $2 \times 10^{-4}$  sec. Real time target acquisition and laser energizing is therefore easily accomplished, in accordance  
5 with a preferred embodiment of the present invention, using nanosecond circuitry and possibly even microsecond circuitry.

Whereas hand unit 22 comprises light source 72 for illuminating a patient's skin, in some preferred embodiments of the present invention light from laser 62 is used to illuminate the patient's skin. During scanning, laser 62 is not turned off but radiates light at low intensity,  
10 which is focused at focal point 54. The low intensity laser light is used to image the patient's skin. When a target is located, controller 24 controls laser 62 to increase the intensity of the laser light that it radiates and send a pulse of laser light that deposits a desired amount of energy on the target.

Fig. 2 schematically shows hand unit 22, which is shown Fig. 1A, in a cutaway view  
15 from a direction parallel to axis of rotation 44 shown in Fig. 1A. In Fig. 2, axis of rotation 44 is represented by a point 44 and beam splitting mirror 66 (Fig. 1A) occupies a shaded area labeled 66. Preferably, hand unit 22 comprises a handle 100. Skin 30 is schematically shown with a hair follicle 102. As a result of the pressure of window 28 on skin 30, skin 30 deforms slightly and molds itself to the shape of surface 29 of window 30. This assures that focal point 54 is  
20 properly positioned with respect to the surface of skin 30.

Oscillatory rotation of microscope 32 about axis of rotation 44 results in oscillatory motion of focal point 54 in the plane of Fig. 2 along an arc 104. Focal point 54 is shown in a number of different positions in Fig. 2. Short witness lines 106 and 108 indicate extreme positions of focal point 54 at the ends of arc 104. A witness line 110 marks the central position  
25 of the motion of focal point 54. Part of optic axis 38 is shown for the positions marked by the witness lines.

Microscope 32 is shown at a point of its motion about axis of rotation 44 at which focal point 54 is positioned at the location of hair follicle 102. At this position microscope 32 images hair follicle 102 on photosensitive surface 78 and controller 24 (Fig. 1A) determines that there  
30 is a target at focal point 54. Laser 62 (Fig. 1A) is controlled to radiate a pulse of light that is focused to spot 70 to coagulate follicle 102.

Whereas in hand unit 22 oscillatory motion of focal point 54 is achieved by rotating microscope 32, in some preferred embodiments of the present invention oscillatory motion of



focal point 54 is achieved by rotating mirror 66. In some preferred embodiments mirror 66 is rotated about axis of rotation 44. In some preferred embodiments of the present invention mirror 66 is rotated about an axis perpendicular to axis of rotation 44 and optic axis 38 that passes through their intersection. Fig. 3 schematically shows laser system 20 being used to depilate skin on an arm 120 of a patient, in accordance with a preferred embodiment of the present invention. The skin on arm 120 is preferably shaved to reveal hair follicles 122 (shown schematically with greatly exaggerated size) that are to be cauterized with laser light radiated from hand unit 22.

Hand unit 22 is held so that window 28 (shown in Figs. 1 and 2) is pressed to the surface of the skin of arm 120. With the surface of window 28 in contact with the patient's skin, hand unit 22 is moved back and forth along arm 120 in a direction indicated by double arrow line 124. Preferably, double arrow line 124 is substantially parallel to axis of rotation 44 of microscope 32, which is mounted inside hand unit 22 (Figs. 1 and 2). The oscillatory motion of microscope 32, causes focal point 54 (Figs. 1 and 2) of the microscope to move back and forth on the skin along a direction indicated by double arrow line 126. Double arrow line 126 is substantially perpendicular to double arrow line 124.

As a result of the motion of focal point 54 in the direction of line 126 in combination with the displacement of hand unit 22 along the direction of line 124, substantially all of a strip 128 of skin located between lines 130 is scanned for hair follicles 128. When these are located they are treated with laser light as described above. The width of strip 128 is substantially equal to the extent of motion of focal point 54 on the skin of arm 120. The length of strip 128 is equal to a distance that hand unit 22 is moved along the direction of double arrow line 30.

Fig. 4 schematically shows a hand unit 150 that is a variation of hand unit 22 shown in Figs 1- 3. Hand unit 150 is shown in a cutaway cross sectional view. Hand unit 150 preferably has a housing, which is not shown in Fig. 4 for clarity of presentation. In hand unit 22 all the optical elements of a microscope are comprised in a single rotating housing. Hand unit 150 on the other hand comprises a microscope 152 in which some of the optical components are mounted in a housing rotatable with respect to the hand unit housing and others are preferably fixed to the hand unit housing.

Components of microscope 152 are shown within dotted boundary curve 154. Microscope 152 has an ocular lens 156 mounted to the housing of hand unit 150 in a fixed position and an objective lens 158 comprised in an elbow shaped housing 160. Objective and ocular lenses 158 and 156 have optical axes 162 and 164 respectively. Objective lens 158

collects light from regions of a patient's skin 30 through a window 166 in the hand unit housing and has a focal point 168 located slightly below window 166.

5 Elbow housing 160 preferably has a circularly cylindrical tubular extension 170 having an axis of rotation 172. Axis of rotation 172 preferably intersects optic axes 162 and 164 at substantially 90°. Tubular extension 170 is mounted to a bearing 174 that is fastened to the hand unit housing. Bearing 174 enables tubular extension 170 to rotate about axis of rotation 172 but preferably prevents tubular extension 172 from moving parallel to axis 172. Tubular extension 170 is coupled to an appropriate motor or actuator (not shown) and rotated in an oscillatory motion about axis of rotation 172 similarly to the way in which tubular extension 42  
10 of microscope 32 is rotated about axis of rotation 44. Focal point 168 therefore oscillates about axis of rotation 172 along an arc (not shown) in the same manner in which focal point 54 of hand unit 22 oscillates about axis of rotation 44 along arc 104 (Fig. 2).

Elbow housing 160 preferably comprises a mirror 176 that reflects light collected by objective 158 to a beam splitter 178. The light is represented by lines 180 having arrows  
15 thereon that indicate the direction in which the light travels. Beam splitter 178 reflects some of light 180 to ocular lens 156. Ocular lens 156 focuses and preferably directs light 180 towards a beam splitter 182 that transmits some of the light to a photosensitive surface 184 and reflects some of the light to a photosensitive surface 186.

Photosensitive surface 184, which is shown in plan view in insert 188, preferably  
20 comprises a quadrant detector 190 that is used to determine the position relative to focal point 168 of a prospective feature for laser treatment on the skin of a patient. Photosensitive surface 186, which is shown in insert 192, preferably comprises a detector 194 having a mask 196 located at the center of detector 194. Light incident on mask 196 does not reach detector 194. Detector 194 is preferably used to determine if the size of a prospective feature for laser  
25 treatment on a patient's skin is larger than a predetermined size. If a prospective feature is centered at focal point 168 its image will be centered on each of photosensitive surfaces 184 and 186. If the feature is larger than a predetermined maximum size, its image will be larger than mask 196 and detector 194 will generate signals responsive to the image indicating that the image is larger than the mask and therefore larger than the predetermined maximum size. In  
30 some preferred embodiments of the present invention quadrature detector 190 has a mask that covers all of quadrature detector 190 except for a region in the center preferably having the same area as mask 196. Masking quadrature detector 190 in this manner increases signal to noise from quadrature detector 190.

Signals generated by photodetectors in detectors 190 and 194 responsive to images of a prospective feature for laser treatment formed on photosensitive surfaces 184 and 186 respectively are transmitted to a controller (not shown). The controller analyzes the signals to determine if the feature is a target to be treated with laser light. In order for a feature to be a target, preferably the location of its centroid, as determined using signals from quadrature detector 190, must lie within a predetermined distance of focal point 168. In addition, preferably the size of the feature, as determined using signals from masked detector 194, must be less than the predetermined maximum size. Hand unit 150 comprises a laser 200 that is controlled by the controller. As in laser system 20 shown in Figs. 1 – 3, when a target is identified, the controller controls laser 200 to radiate a pulse of laser light to irradiate the target. Laser light radiated from laser 200 is piped by a light guide 202 to a collimating lens 204 that transmits the laser light to beam splitter 178. The laser light is represented by lines 206 having arrows thereon that indicate the direction of travel of the laser light. Some of laser light 206 is transmitted by beam splitter 178 to mirror 176, which reflects laser light 180 to objective lens 158. Objective lens 158 focuses the laser light to a spot 208. The predetermined maximum distance, maximum size and the size of spot 208 are preferably determined responsive to the size of a feature to be treated with laser light so that when a feature is determined to be a target, spot 208 will substantially cover all of the target.

In the description and claims of the present application, each of the verbs, “comprise” “include” and “has”, and conjugates thereof, are used to indicate that the object or objects of the verb are not necessarily a complete listing of components, elements or parts of the subject or subjects of the verb.

The present invention has been described using non-limiting detailed descriptions of preferred embodiments thereof that are provided by way of example and are not intended to limit the scope of the invention. Variations of embodiments described will occur to persons of the art. For example, in some preferred embodiments of the present invention the hand unit comprises a processor for processing data from photosensitive surfaces and determining whether a feature on the skin of a patient is a target. Whereas, oscillatory motion of the focal points of a microscope in a hand units has been described as resulting from rotational motion of the microscope the motion can be also be achieved by linear motion of the microscope. Furthermore, different configurations of photodetectors on photosensitive surfaces, other than those described, can also be used for locating and sizing prospective targets for laser treatment,

and these will occur to a man of the art. The scope of the invention is limited only by the following claims.

## CLAIMS

1. A laser system for treating features on the skin of a patient with laser light comprising:  
an imaging subsystem that locates features on the skin to be treated;  
5 a laser;  
laser optics that focuses light from the laser onto a feature located by the imaging  
subsystem; and  
a controller, that when a feature is located, controls the laser to radiate a pulse of laser light that  
is focused by the laser optics to a spot localized about the feature.
- 10 2. A laser system according to claim 1 comprising a light source that illuminates regions  
imaged by the imaging optics with light for which the features to be treated have a reflectance  
different from that of clear skin so that a feature to be treated appears as a contrasted sub-region  
of an imaged region of the skin.
- 15 3. A laser system according to claim 2 wherein the spectrum of the light radiated by the  
light source is tunable.
4. A laser system according to any of the preceding claims wherein the spot to which the  
20 laser is focused has an area substantially equal to an area characteristic of the size distribution  
of areas occupied on the skin by features to be treated, multiplied by a factor greater than one.
5. A laser system according to claim 4 wherein the factor is less than 2.
- 25 6. A laser system according to claim 4 wherein the factor is less than 1.5.
7. A laser system according to any of claims 4-6 wherein the factor is greater than about  
1.2.
- 30 8. A laser system according to any of the preceding claims wherein the controller controls  
the laser to radiate a pulse of light only if a located feature occupies an area on the skin  
consistent with the size distribution of areas occupied on the skin by features to be treated.

9. A laser system according to any of the preceding claims wherein the imaging subsystem scans an area of the skin and during scanning automatically locates features on the area to be treated.
- 5 10. A laser system according to any of the preceding claims wherein the imaging subsystem comprises:  
at least one photosensitive surface that generates signals responsive to an image formed thereon; and  
imaging optics that images light that it collects on the at least one photosensitive  
10 surface;  
wherein, to scan the area, the imaging optics are moved relative to the skin so as to image regions in the scanned area onto the at least one photosensitive surface.
11. A laser system according to claim 10 wherein the imaging optics has a focal point and  
15 the spot to which the pulse of laser light is focused is centered at the imaging optics focal point.
12. A laser system according to claim 11 wherein the controller controls the laser to radiate a pulse of light only if a feature to be treated is determined to lie substantially within an area centered at the imaging optics focal point having a size substantially equal to the size of the  
20 spot to which the laser pulse is focused.
13. A laser system according to any of the preceding claims comprising circuitry that receives signals generated by the at least one photosurface responsive to an imaged region of the skin and processes the signals to locate contrasted sub-regions in the imaged region to  
25 locate features to be treated.
14. A laser system according to claim 13 wherein the at least one photosensitive surface comprises a single photosensitive surface.
- 30 15. A laser system according to claim 14 wherein the photosensitive surface comprises a quadrature detector.

16. A laser system according to claim 15 wherein signals from the quadrature detector are used to determine whether a contrasted sub-region imaged on the quadrature detector is substantially centered within the spot to which the laser pulse is focused.
- 5 17. A laser system according to claim 15 or claim 16 wherein signals from the quadrature detector are used to determine whether a contrasted sub-region imaged on the quadrature detector is larger than a predetermined minimum size consistent with the size distribution of areas occupied on the skin by features to be treated.
- 10 18. A laser system according to any of claims 15 - 17 wherein the photosensitive surface additionally comprises at least two photodetectors located adjacent to opposite sides of the quadrature detector.
- 15 19. A laser system according to claim 18 wherein if any of the photodetectors adjacent to sides of the quadrature detector generates a signal responsive to a contrasted sub-region imaged on the photosensitive surface, a portion of the sub-region is determined to lie outside the spot to which the laser pulse is focused and the laser is not energized.
- 20 20. A laser system according to claim 13 wherein the at least one photosurface comprises a first and a second photosensitive surface.
21. A laser system according to claim 20 wherein the first photosensitive surfaces comprises a quadrature detector.
- 25 22. A laser system according to claim 21 wherein signals from the quadrature detector are used to determine whether a contrasted sub-region imaged on the quadrature detector is substantially centered within the spot to which the laser pulse is focused.
- 30 23. A laser system according to claim 21 or claim 22 wherein signals from the quadrature detector are used to determine whether a contrasted sub-region imaged on the quadrature detector is larger than a predetermined minimum size consistent with the size distribution of areas occupied on the skin by features to be treated.

24. A laser system according to any of claims 20 - 23 wherein the second detector comprises a photodetector having a mask that blocks light from impinging on an area located at its center.
- 5 25. A laser system according to claim 24 wherein if the photosensitive surface generates signals responsive to a contrasted sub-region imaged on the photosensitive surface, a portion of the sub-region is determined to lie outside of the spot to which the laser pulse is focused and the laser is not energized.
- 10 26. A laser system according to any of claims 10 – 21 wherein the imaging optics comprises an objective lens system having a focal point that collects light from regions imaged by the imaging subsystem and wherein the focal point of the imaging optics is the focal point of the objective lens system.
- 15 27. A laser system according to claim 26 wherein the imaging system comprises an ocular lens system that receives light collected by the objective lens system and images the received light on the at least one photosensitive surface.
28. A laser system according to claim 27 wherein the objective lens system is rotatable  
20 about an axis of rotation that intersects the optic axis of the objective lens system.
29. A laser system according to claim 28 wherein the laser optics comprises a collimating  
25 lens system that receives light radiated by the laser, which it collimates and transmits parallel to the axis of rotation.
30. A laser system according to claim 29 wherein the imaging optics comprises a reflector  
30 that reflects the collimated laser light towards the objective lens system along a direction parallel to the optic axis of the objective lens system so that the laser light is focused to a spot at the focal point of the objective lens system.
31. A laser system according to claim 30 wherein the reflector is a beam splitter.



32. A laser system according to claim 31 wherein the ocular lens system and the at least one photosensitive surface are positioned on a side of the reflector opposite to the side of the reflector on which the objective lens system is located.
- 5 33. A laser system according to claim 30 wherein the reflector is a mirror.
34. A laser system according to claim 33 wherein the ocular optics and the at least one photosensitive surface are stationary with respect to the axis of rotation.
- 10 35. A laser system according to claim 34 comprising a beam splitter positioned between the collimating lens and the mirror and wherein light collected by the objective optics is reflected by the mirror along the axis of rotation towards the beam splitter, which reflects some of the collected light incident on it towards the ocular lens system.
- 15 36. A laser system according to any of claims 28 - 35 comprising a motor or actuator that is coupled to the objective lens system and rotates the objective lens system with an oscillatory motion about the axis of rotation, so that the objective focal point moves back and forth along a planar arc having a fixed length.
- 20 37. A laser system according to any of claims 10 – 32 wherein the imaging optics and the at least one photosensitive surface are mounted within a hand held unit.
38. A laser system according to claim 37 wherein the light source is mounted in or on the hand held unit.
- 25 39. A laser system according to claim 37 or claim 38 wherein the laser is mounted within the hand held unit.
40. A laser system according to any of claims 37 – 39 wherein the controller is mounted in  
30 the hand held unit.
41. A laser system according to any of claims 37 – 40 comprising a power source mounted in the hand held unit.

42. A method for treating features on the skin of a patient with laser light comprising:  
optically scanning the patient's skin to locate features to be treated; and  
during scanning, when a feature is located, focusing a pulse of laser light energy to a  
5 spot that covers substantially completely the feature, which spot has an area substantially equal  
to an area characteristic of the size distribution of areas occupied on the skin by features to be  
treated, multiplied by a factor greater than one.
43. A method for depilating a patient's skin using laser light comprising:  
10 optically scanning the patient's skin to locate hair follicles in regions of the skin to be  
depilated; and  
during scanning, when a hair follicle is located, cauterizing the hair follicle by focusing  
a pulse of laser light energy to a spot that shadows substantially completely the hair follicle,  
which spot has an area substantially equal to an area characteristic of the size distribution of  
15 areas occupied on the skin by hair follicles, multiplied by a factor greater than one.
44. A method according to claim 42 or claim 43 wherein the factor is less than 2.
45. A method according to claim 42 or claim 43 wherein the factor is less than 1.5.  
20
46. A method according to any of claims 42-45 wherein the factor is greater than about 1.2.
47. A method according to any of claims 42 - 46 wherein scanning comprises moving an  
optical imaging system having a focal point over the patients skin to image different regions of  
25 the skin.
48. A method according to claim 47 wherein moving an optical imaging system comprises  
moving the focal point close to and along the patient's skin.
- 30 49. A method according to claim 47 or claim 48 wherein focusing a pulse of laser light  
energy comprises focusing the energy to a spot centered at the focal point.

50. A method according to claim 47 - 49 comprising analyzing imaged regions of the skin to locate features to be treated.

51. A method according to claim 50 wherein analyzing imaged regions comprises determining whether an imaged region of the skin has a feature having a size consistent with the size distribution of areas occupied on the skin by features to be treated.

52. A method according to claim 50 or claim 51 wherein analyzing imaged regions comprises determining whether an imaged region of the skin has a feature to be treated located within a localized region on the skin which is centered at the focal point.

53. A method according to claim 48 wherein the localized region is substantially equal to the size of the spot to which the laser light is focused.

54. A method according to any of claims 48 - 53 wherein moving the focal point comprises moving the focal point with an oscillatory motion along a first direction on the skin.

55. A method according to claim 54 and comprising moving the focal point in a second direction substantially perpendicular to the first direction while the focal point is oscillating.

56. A method according to any of claims 47 - 55 wherein moving the optical imaging system comprises moving the optical imaging system by hand.

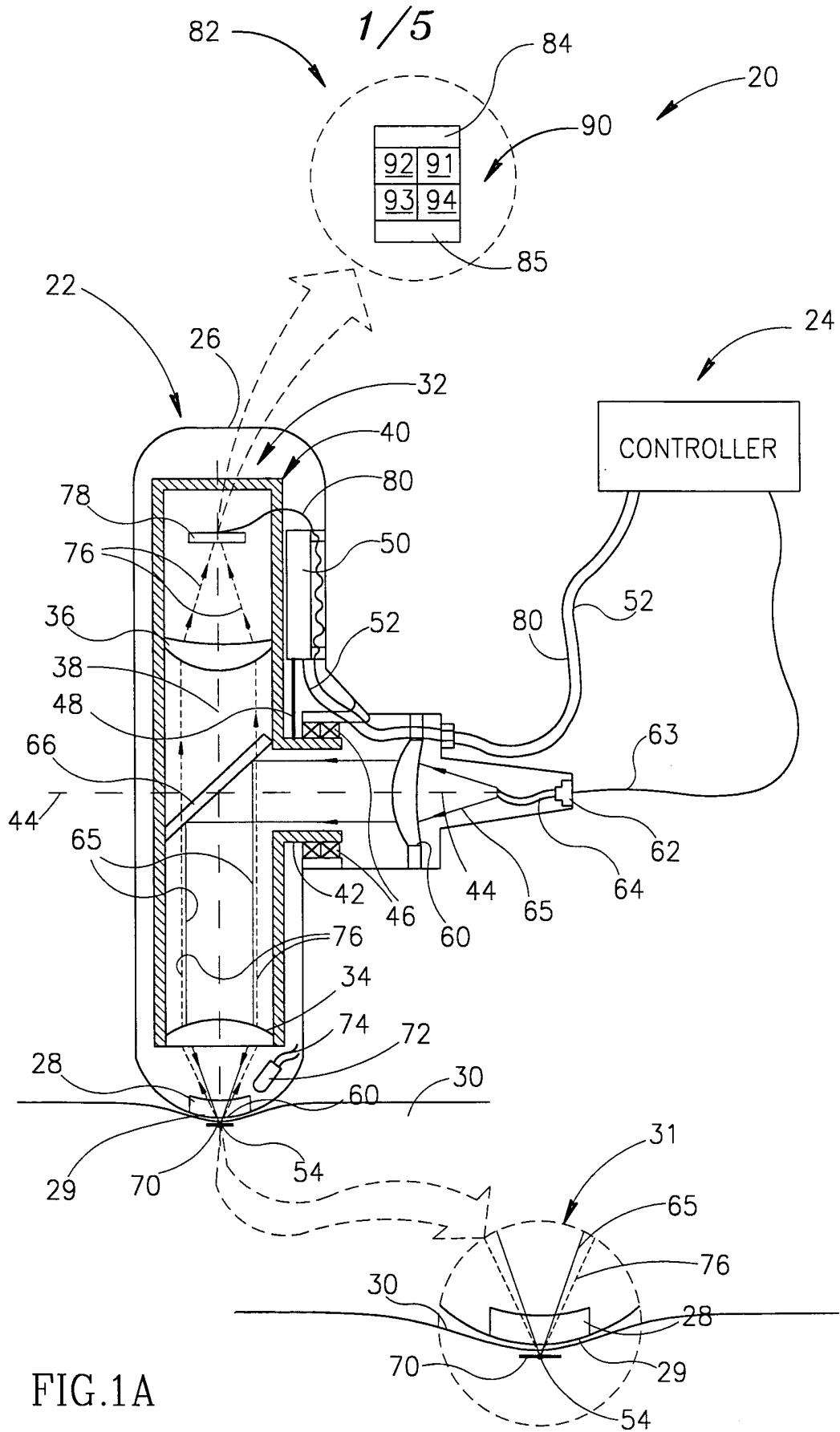

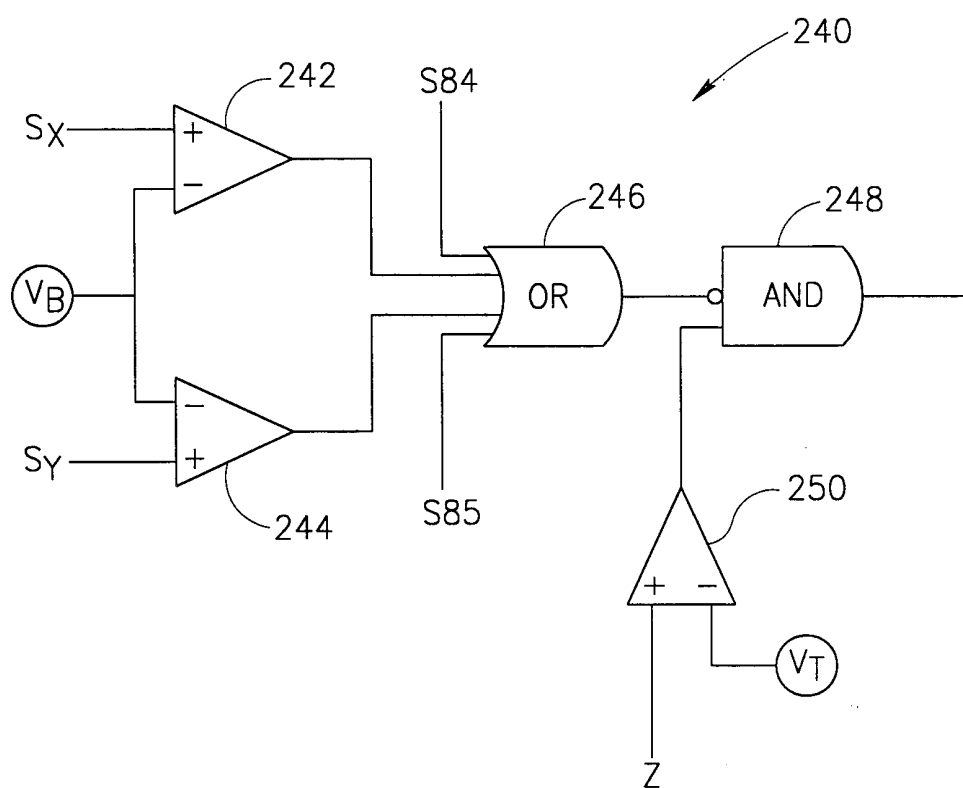

FIG.1B

3/5

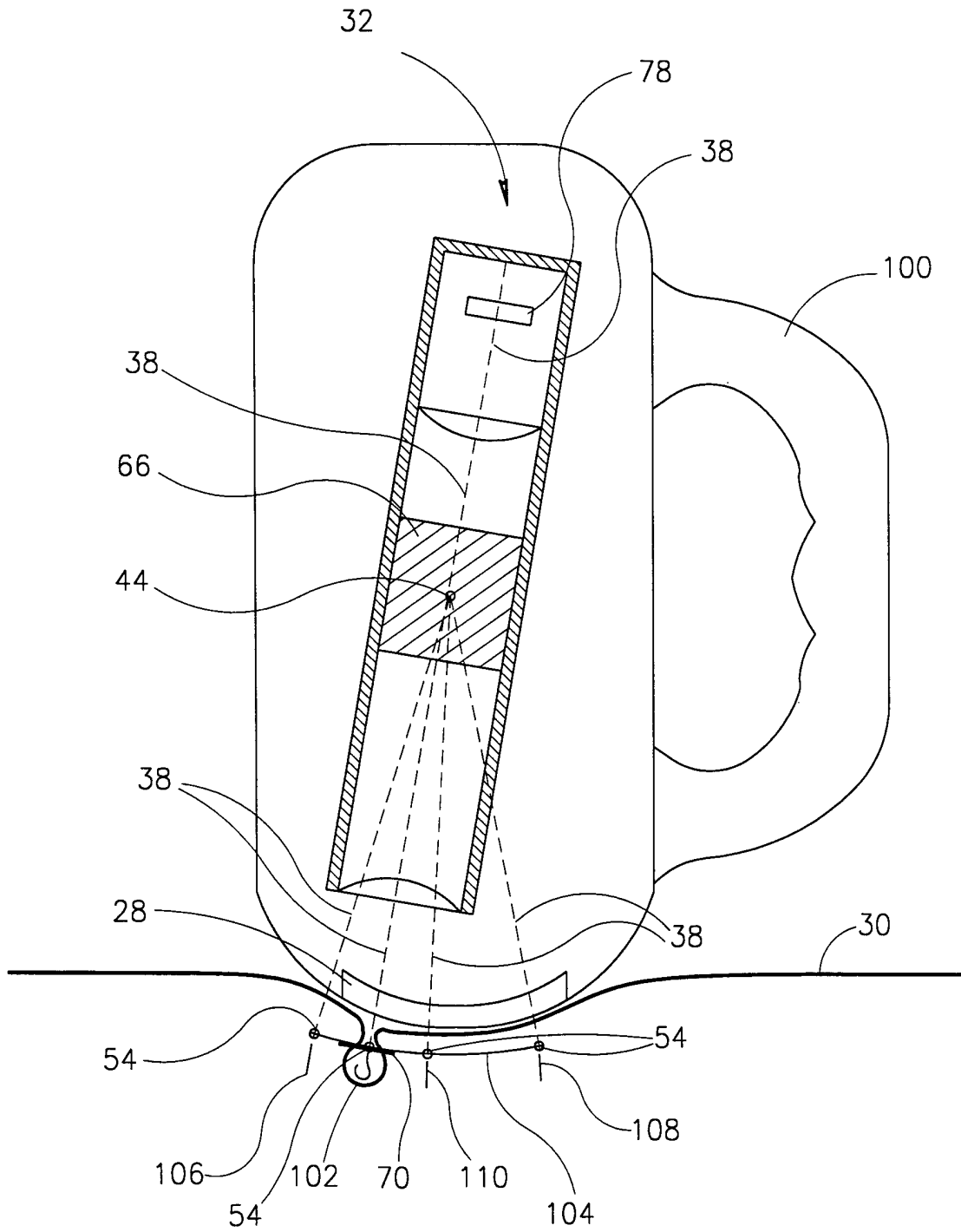

FIG.2

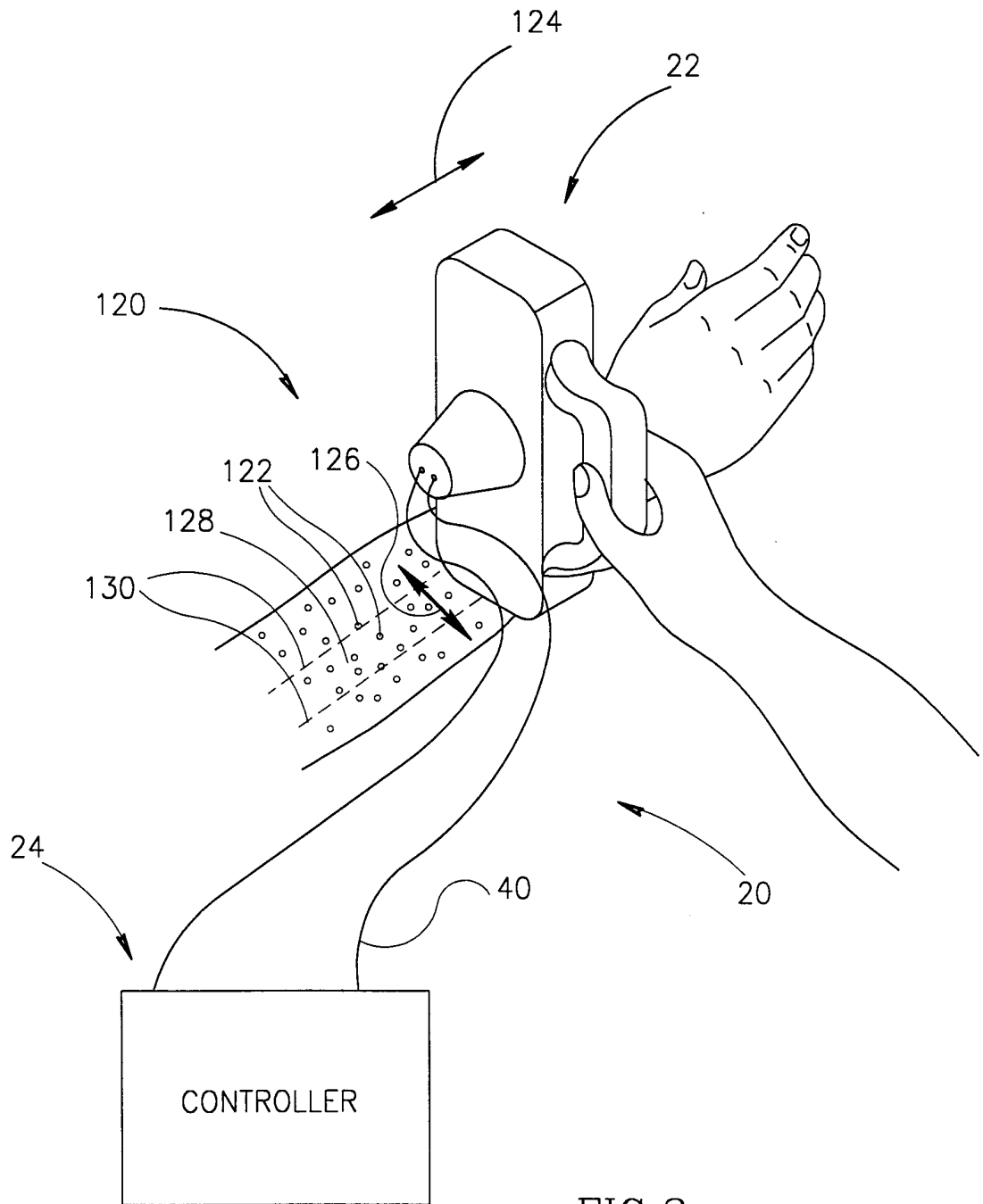

FIG.3

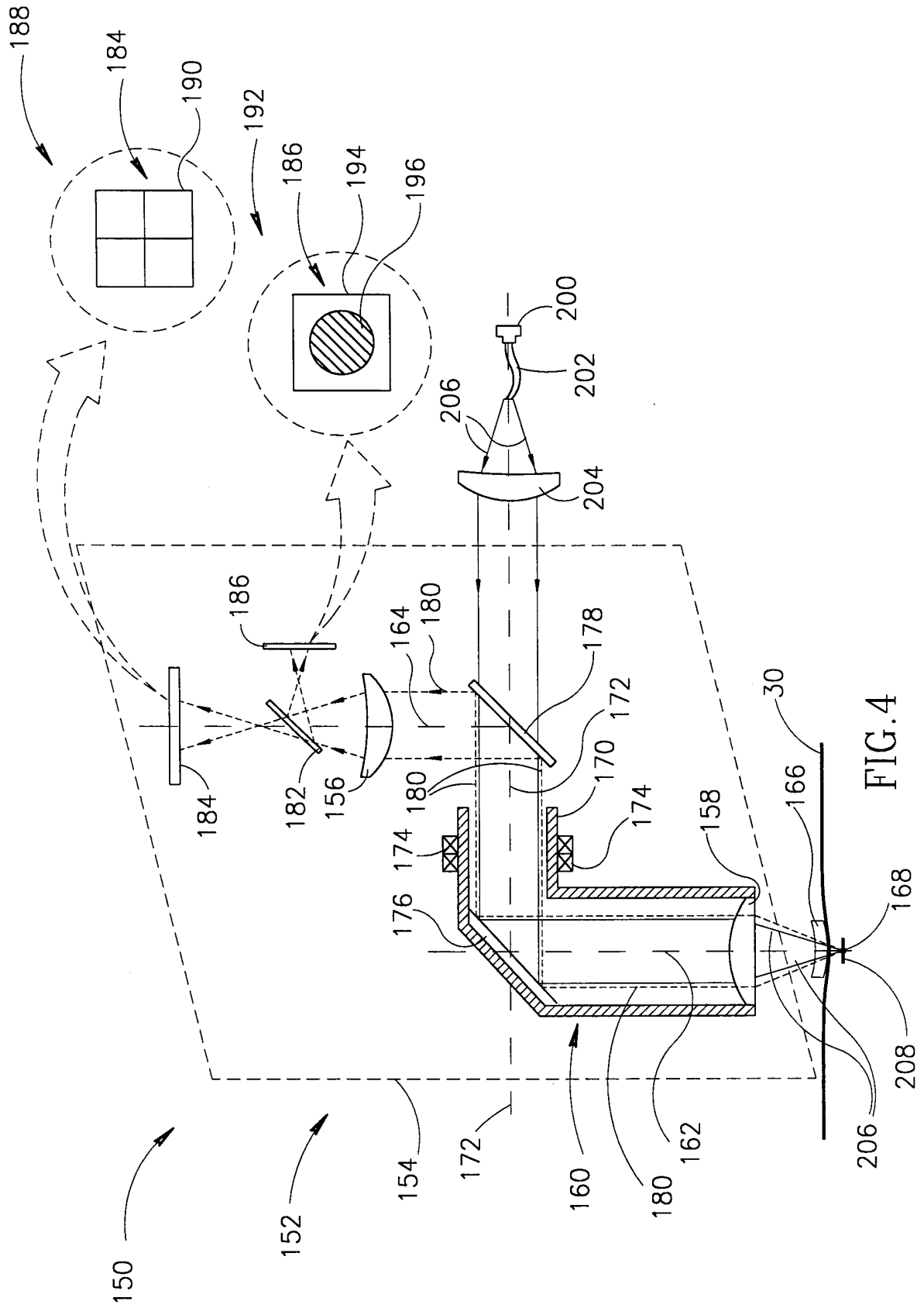

FIG. 4



# INTERNATIONAL SEARCH REPORT

International Application No

PCT/IL 99/00279

**A. CLASSIFICATION OF SUBJECT MATTER**  
IPC 7 A61B18/20

According to International Patent Classification (IPC) or to both national classification and IPC

**B. FIELDS SEARCHED**

Minimum documentation searched (classification system followed by classification symbols)

IPC 7 A61B A61N

Documentation searched other than minimum documentation to the extent that such documents are included in the fields searched

Electronic data base consulted during the international search (name of data base and, where practical, search terms used)

**C. DOCUMENTS CONSIDERED TO BE RELEVANT**

Category <sup>o</sup>	Citation of document, with indication, where appropriate, of the relevant passages	Relevant to claim No.
X	WO 99 11324 A (BALLE PETERSEN OLAV ;ASAH BJARNE (DK); ASAH MEDICO A S (DK); DOLLE) 11 March 1999 (1999-03-11) page 3, line 12 - line 22 page 6, line 9 - line 33 page 11, line 20 -page 12, line 21 page 14, line 8 - line 31 page 19, line 9 -page 20, line 20 ---	1-4,8,9, 13,14,43
X	DE 38 37 248 A (TEICHMANN HARRO DR MED ;TEICHMANN HEINRICH OTTO DR PHY (DE)) 3 May 1990 (1990-05-03) column 1, line 40 -column 4, line 38 ---	1,2,9,13
X	EP 0 880 941 A (NIDEK KK) 2 December 1998 (1998-12-02) column 15, line 43 -column 17, line 15; claim 11 ---	1,2,9,13
-/--		

Further documents are listed in the continuation of box C.

Patent family members are listed in annex.

<sup>o</sup> Special categories of cited documents :

- "A" document defining the general state of the art which is not considered to be of particular relevance
- "E" earlier document but published on or after the international filing date
- "L" document which may throw doubts on priority claim(s) or which is cited to establish the publication date of another citation or other special reason (as specified)
- "O" document referring to an oral disclosure, use, exhibition or other means
- "P" document published prior to the international filing date but later than the priority date claimed

- "T" later document published after the international filing date or priority date and not in conflict with the application but cited to understand the principle or theory underlying the invention
- "X" document of particular relevance; the claimed invention cannot be considered novel or cannot be considered to involve an inventive step when the document is taken alone
- "Y" document of particular relevance; the claimed invention cannot be considered to involve an inventive step when the document is combined with one or more other such documents, such combination being obvious to a person skilled in the art.
- "&" document member of the same patent family

Date of the actual completion of the international search

19 January 2000

Date of mailing of the international search report

26/01/2000

Name and mailing address of the ISA

European Patent Office, P.B. 5818 Patentlaan 2  
 NL - 2280 HV Rijswijk  
 Tel. (+31-70) 340-2040, Tx. 31 651 epo nl,  
 Fax: (+31-70) 340-3016

Authorized officer

Petter, E

INTERNATIONAL SEARCH REPORT

International Application No  
PCT/IL 99/00279

C.(Continuation) DOCUMENTS CONSIDERED TO BE RELEVANT		
Category	Citation of document, with indication, where appropriate, of the relevant passages	Relevant to claim No.
X	US 5 531 740 A (BLACK MICHAEL) 2 July 1996 (1996-07-02) page 3, line 29 -page 5, line 18; figures 1,2 ---	1,2,9, 10,13
X	US 5 628 744 A (DAVENPORT SCOTT A ET AL) 13 May 1997 (1997-05-13) column 2, line 36 - line 50 -----	1,2,9,13

# INTERNATIONAL SEARCH REPORT

International application No.

PCT/IL 99/00279

## Box I Observations where certain claims were found unsearchable (Continuation of item 1 of first sheet)

This International Search Report has not been established in respect of certain claims under Article 17(2)(a) for the following reasons:

1.  Claims Nos.: 42  
because they relate to subject matter not required to be searched by this Authority, namely:  
Rule 39.1 (iv) PCT - Method for treatment of the human or animal body by therapy
2.  Claims Nos.:  
because they relate to parts of the International Application that do not comply with the prescribed requirements to such an extent that no meaningful International Search can be carried out, specifically:
3.  Claims Nos.:  
because they are dependent claims and are not drafted in accordance with the second and third sentences of Rule 6.4(a).

## Box II Observations where unity of invention is lacking (Continuation of item 2 of first sheet)

This International Searching Authority found multiple inventions in this international application, as follows:

1.  As all required additional search fees were timely paid by the applicant, this International Search Report covers all searchable claims.
2.  As all searchable claims could be searched without effort justifying an additional fee, this Authority did not invite payment of any additional fee.
3.  As only some of the required additional search fees were timely paid by the applicant, this International Search Report covers only those claims for which fees were paid, specifically claims Nos.:
4.  No required additional search fees were timely paid by the applicant. Consequently, this International Search Report is restricted to the invention first mentioned in the claims; it is covered by claims Nos.:

### Remark on Protest

- The additional search fees were accompanied by the applicant's protest.
- No protest accompanied the payment of additional search fees.

# INTERNATIONAL SEARCH REPORT

Information on patent family members

International Application No

PCT/IL 99/00279

Patent document cited in search report	A	Publication date	Patent family member(s)	Publication date
WO 9911324	A	11-03-1999	AU 8851898 A	22-03-1999
DE 3837248	A	03-05-1990	NONE	
EP 0880941	A	02-12-1998	JP 10328201 A	15-12-1998
			JP 11019090 A	26-01-1999
			JP 11070119 A	16-03-1999
			JP 11070120 A	16-03-1999
US 5531740	A	02-07-1996	NONE	
US 5628744	A	13-05-1997	AU 1446595 A	10-07-1995
			CA 2179600 A	29-06-1995
			EP 0735841 A	09-10-1996
			NZ 278275 A	24-02-1997
			WO 9517130 A	29-06-1995