



US007253709B1

(12) **United States Patent**
Chang et al.

(10) **Patent No.:** **US 7,253,709 B1**
(45) **Date of Patent:** **Aug. 7, 2007**

(54) **RF MEMS SWITCH WITH SPRING-LOADED LATCHING MECHANISM**

2004/0164825 A1* 8/2004 Volant et al. 335/78

OTHER PUBLICATIONS

(75) Inventors: **David T. Chang**, Calabasas, CA (US);
James H. Schaffner, Chatsworth, CA (US);
Tsung-Yuan Hsu, Westlake Village, CA (US);
Adele E. Schmitz, Newbury Park, CA (US)

Harness, T., et al., "Characteristic Modes of Electrostatic Comb-Drive X-Y Microactuators," *J. Micromech. Microeng.*, vol. 9, 1-8 (1999).

Hyman, D., et al., "GaAs-Compatible Surface-Micromachined RF MEMS Switches," *Electronics Letters*, vol. 35, No. 3, pp. 1-2 (Feb. 4, 1999).

Sun, Xi-Qing, et al., "A Bistable Microrelay Based on Two-Segment Multimorph Cantilever Actuators," *The Eleventh Annual International Workshop on Micro-electro Mechanical Systems*, pp. 154-159 (Jan. 25-29, 1998).

(73) Assignee: **HRL Laboratories, LLC**, Malibu, CA (US)

(*) Notice: Subject to any disclaimer, the term of this patent is extended or adjusted under 35 U.S.C. 154(b) by 207 days.

* cited by examiner

Primary Examiner—Elvin Enad

Assistant Examiner—Bernard Rojas

(74) *Attorney, Agent, or Firm*—Ladas & Parry

(21) Appl. No.: **10/961,732**

(22) Filed: **Oct. 7, 2004**

(51) **Int. Cl.**
H01H 51/22 (2006.01)

(52) **U.S. Cl.** **335/78; 200/181**

(58) **Field of Classification Search** **335/78; 200/181**

See application file for complete search history.

(57) **ABSTRACT**

Apparatus for a micro-electro-mechanical switch that provides for latching switching action. The switch has a cantilever arm disposed on a substrate that can be moved in orthogonal directions for latching and unlatching. To latch the switch, the cantilever arm is moved back by a comb-drive actuator and then pulled down by electrodes disposed on the substrate and the cantilever arm. The comb-drive actuator switch is then released and the cantilever arm moves forward to be captured by a dove-tail structure on the substrate. When the voltage to the electrodes on the substrate and the cantilever arm is removed, the cantilever arm is held in place by the dove-tail structure. The switch is unlatched by actuating the comb-drive actuator to move the cantilever arm away from the dove-tail structure. The cantilever arm will then pop up once it is released from the dove-tail structure.

(56) **References Cited**

U.S. PATENT DOCUMENTS

| | | | |
|----------------|---------|------------------|---------|
| 5,121,089 A | 6/1992 | Larson | 333/107 |
| 5,351,412 A | 10/1994 | Furuhata et al. | 33/568 |
| 5,418,418 A | 5/1995 | Hirano et al. | 310/328 |
| 6,046,659 A | 4/2000 | Loo et al. | 333/262 |
| 6,331,257 B1 | 12/2001 | Loo et al. | 216/13 |
| 6,496,612 B1 | 12/2002 | Ruan et al. | 385/18 |
| 6,509,670 B2 * | 1/2003 | Jeong et al. | 310/309 |
| 6,798,315 B2 * | 9/2004 | Schaefer | 333/105 |
| 7,138,893 B2 * | 11/2006 | Nakanishi et al. | 335/78 |

17 Claims, 6 Drawing Sheets

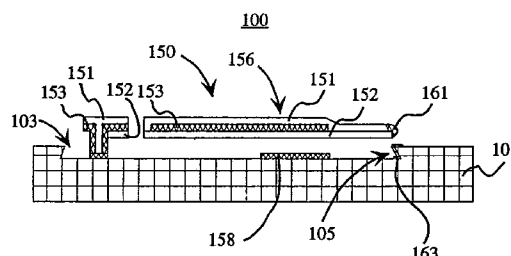
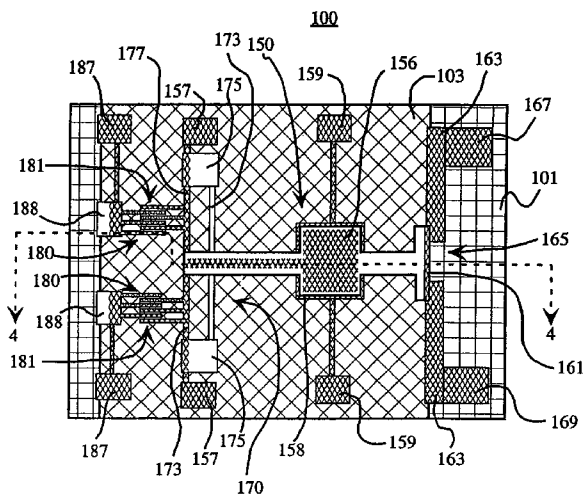

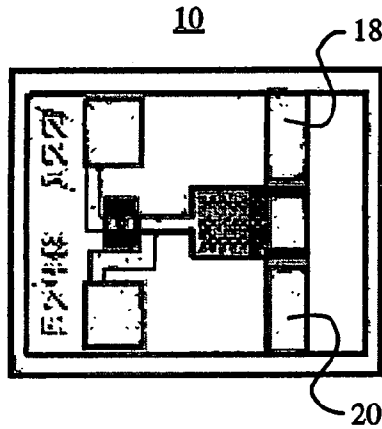

FIG. 1
(Prior Art)

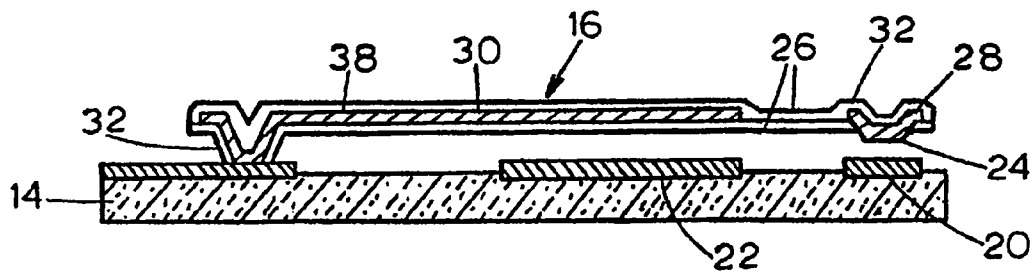

FIG. 2A
(Prior Art)

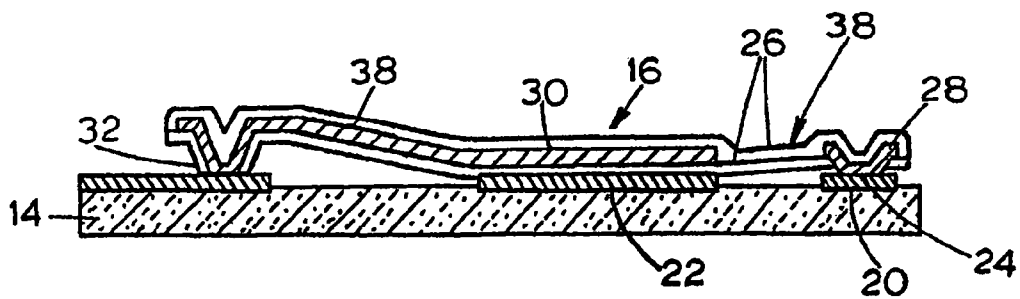

FIG. 2B
(Prior Art)

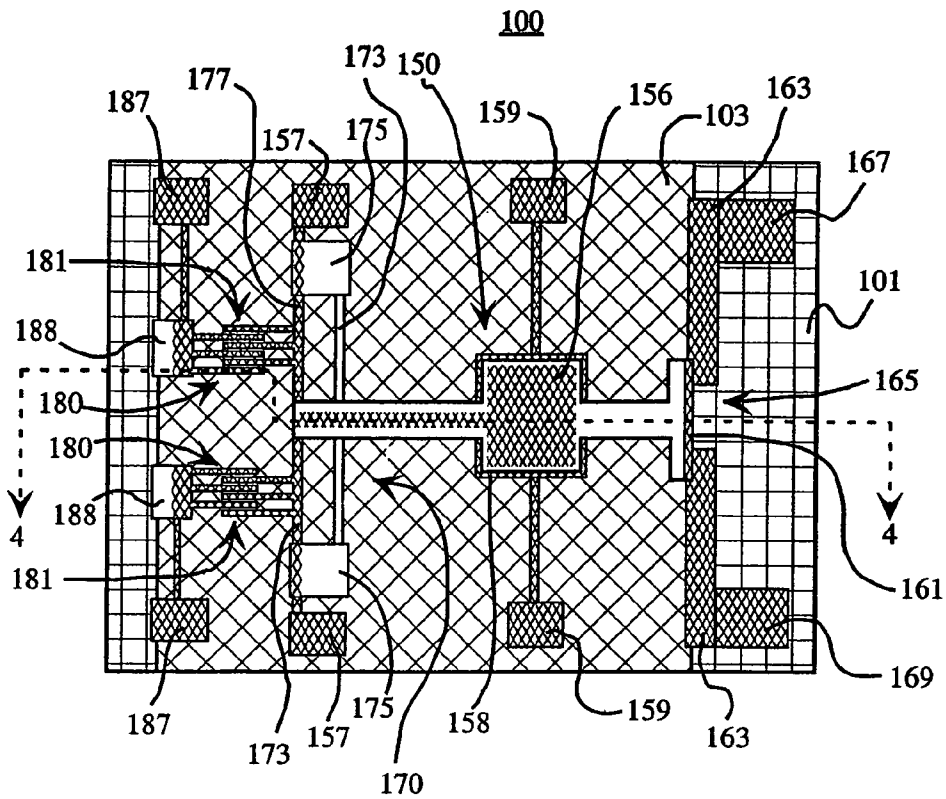

FIG. 3

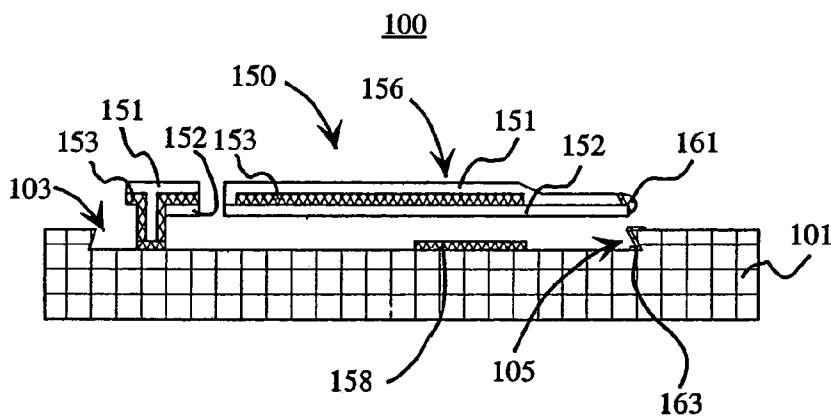

FIG. 4

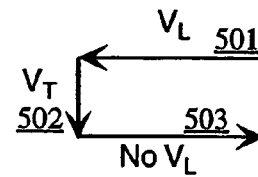

FIG. 5

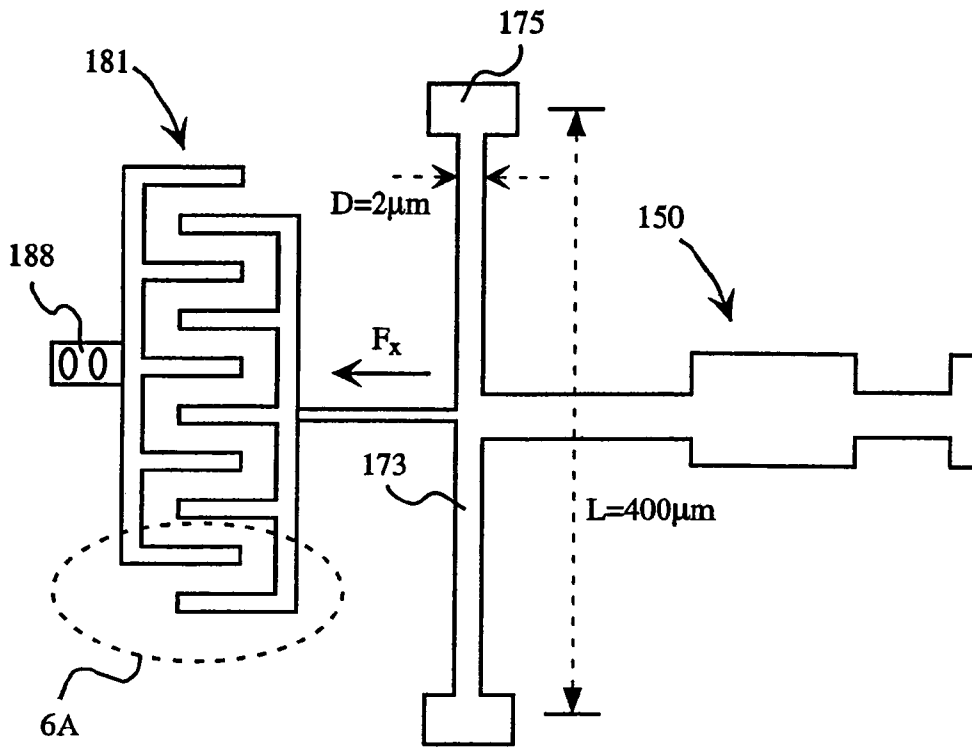

FIG. 6

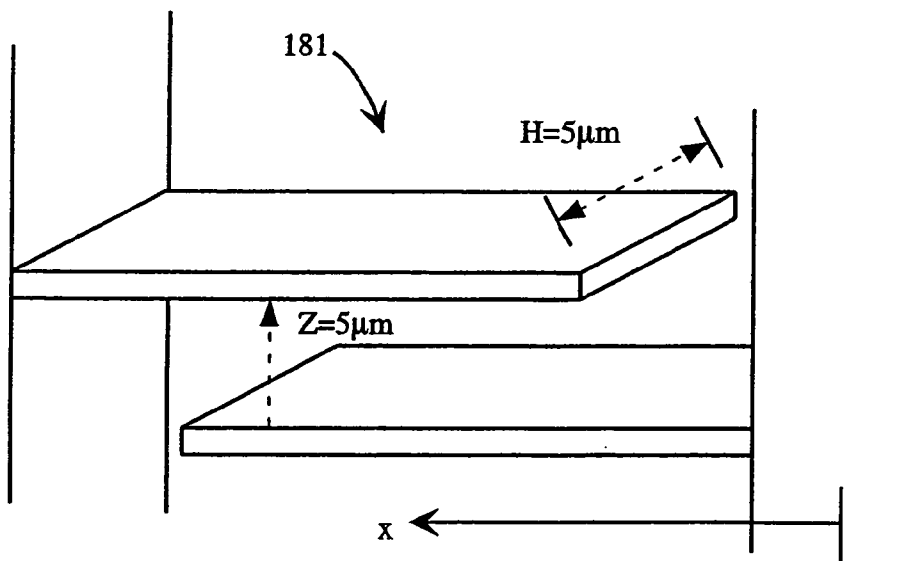

FIG. 6A

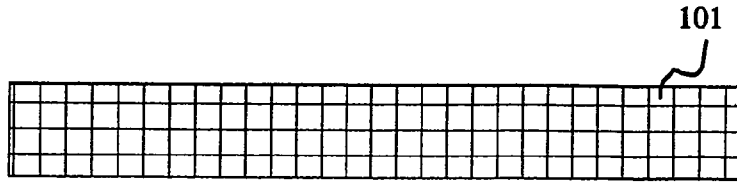

FIG. 7A

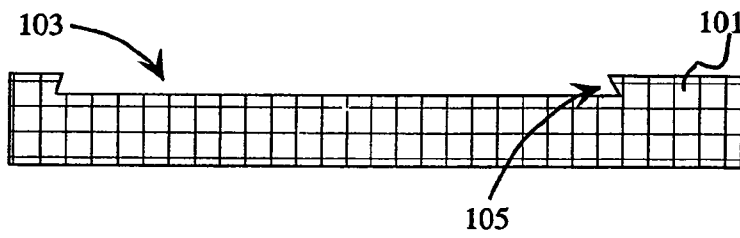

FIG. 7B

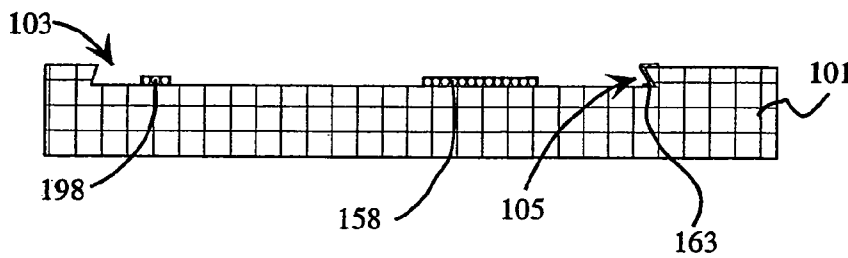

FIG. 7C

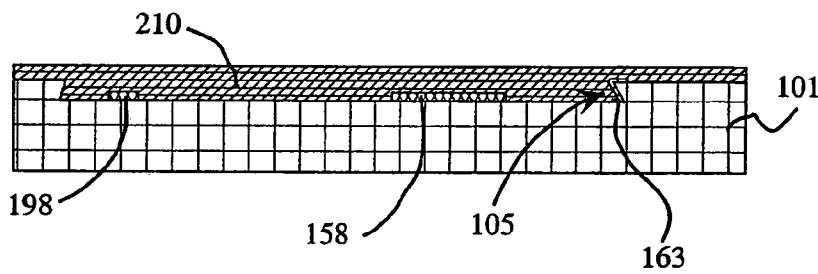

FIG. 7D

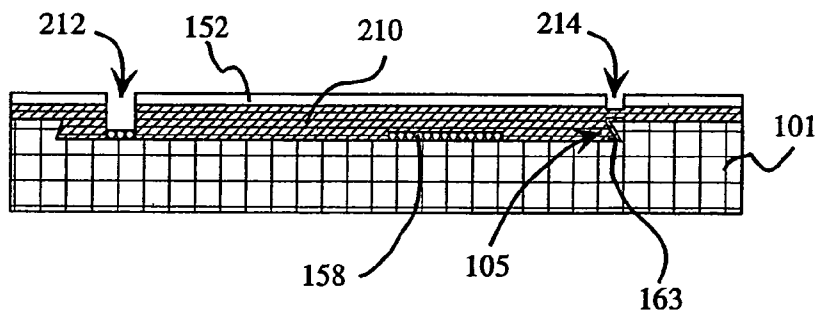

FIG. 7E

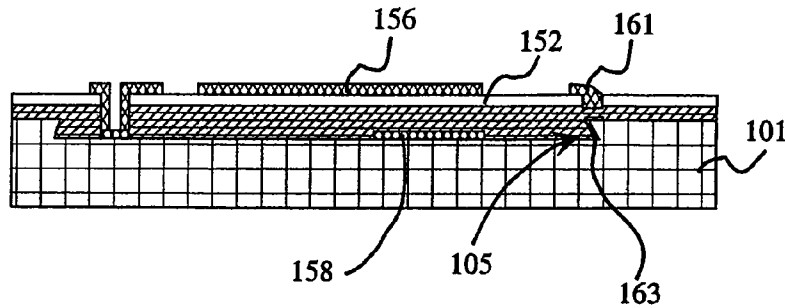

FIG. 7F

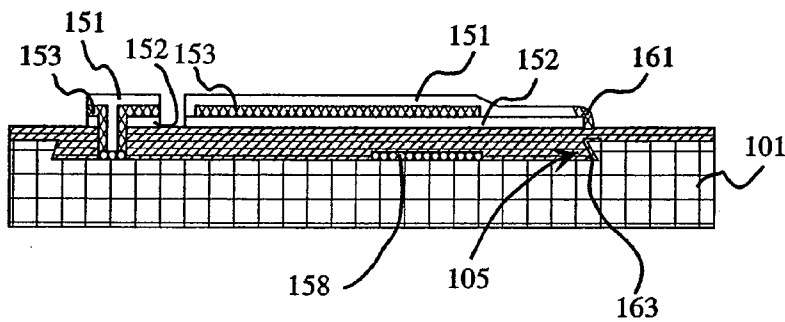

FIG. 7G

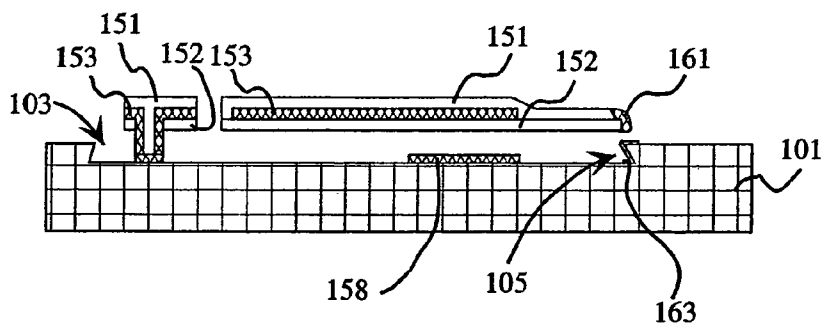

FIG. 7H

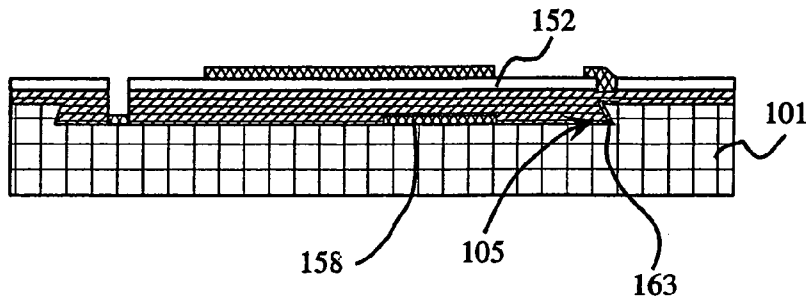

FIG. 8A

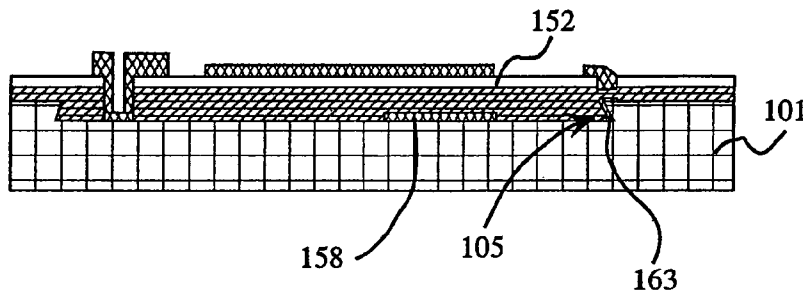

FIG. 8B

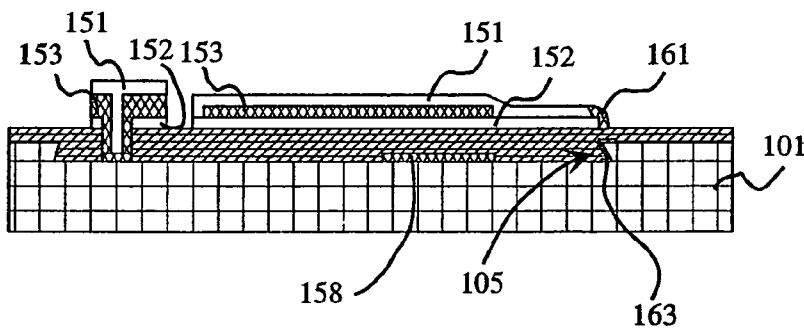

FIG. 8C

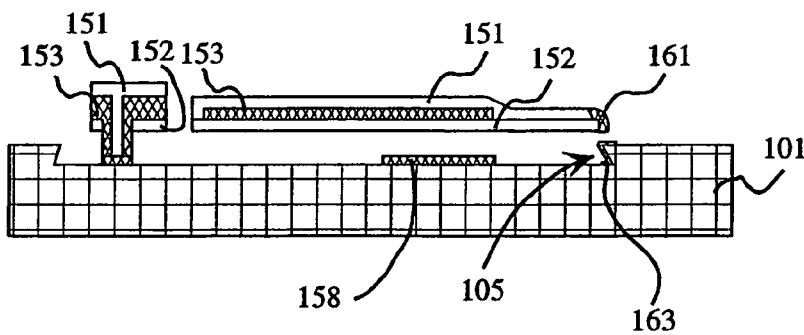

FIG. 8D

RF MEMS SWITCH WITH SPRING-LOADED LATCHING MECHANISM

BACKGROUND

1. Technical Field

The present disclosure relates generally to switches. More particularly, this disclosure relates to microfabricated electromechanical switches having a spring-loaded latching mechanism.

2. Description of Related Art

Switch networks are found in many systems application. For example, in satellite systems, switch networks are essential for routing matrices and redundancy systems. Future satellite systems will not only require larger switch routing networks, but also increased functionality for network-centric operations. These new capabilities will include spacecraft reconfiguration for beam switching, beam shaping, and frequency agility. Thus, it is expected that satellites will require an increasing number of switches in their payloads.

In many cases, these switches need to be latching, that is, once they are actuated they will remain in a desired state even after the actuation energy source is removed. Some of the applications where latching switches are important are ultra-reliable networks where power interruptions could create a problem, such as satellite or Unmanned Air Vehicles, or networks where supplied power is limited, like in small mobile platforms that run on batteries. Current latching switch technology typically relies on magnetic or motor drives to change switch states. These switches, typically fabricated using coaxial conductors or metallic waveguide, generally work very well. However, most of the applications listed above would benefit from size and weight reduction since the mechanical latching switches currently in use tend to be larger and heavier than desired. Semiconductor switches, such as made using PIN diodes and FET switches, are small, but they typically cannot latch in multiple states without a constant energy source.

Radio Frequency (RF) Micro Electro-Mechanical System (MEMS) switches are known in the art to have small size and weight and are also known to provide desirable performance in the radio frequency and microwave spectrums. Several types of MEMS switches are well-known in the art. For example, U.S. Pat. No. 5,121,089 issued Jun. 9, 1992 to Larson discloses a microwave MEMS switch. The Larson MEMS switch utilizes an armature design. One end of a metal armature is affixed to an output line, and the other end of the armature rests above an input line. The armature is electrically isolated from the input line when the switch is in an open position. When a voltage is applied to an electrode below the armature, the armature is pulled downward and contacts the input line. This creates a conducting path between the input line and the output line through the metal armature. This switch requires a constant voltage to maintain the switch in a closed state.

As another example, U.S. Pat. No. 6,046,659 of Loo et al. discloses methods for the design and fabrication of non-latching single pole single throw MEMS switches. U.S. Pat. No. 6,046,659 is incorporated herein by reference in its entirety. FIG. 1 shows a top view of a MEMS switch 10 according to Loo et al, which provides single pole single throw switching between an input line 20 and an output line 18.

FIGS. 2A and 2B are side-elevation views of the MEMS switch 10. FIG. 2A shows the switch 10 in the open position and FIG. 2B shows the switch 10 in the closed position.

Beam structural material 26 is connected to a substrate 14 through a fixed anchor via 32. A suspended armature bias electrode 30 is nested within the structural material 26 and electrically accessed through a bias line 38 at an armature bias pad 34. A conducting transmission line 28 is at the free end of the beam structural layer 26 and is electrically isolated from the suspended armature bias electrode 30 by the dielectric structural layer 26. Contact dimples 24 of the transmission line 28 extend through and below the structural layer 26 and define the areas of metal contact to the input and output lines 20 and 18, respectively. A substrate bias electrode 22 is below a suspended armature bias electrode 30 on the surface of the substrate 14. When a voltage is applied between the suspended armature bias electrode 30 and the substrate bias electrode 22, an electrostatic attractive force will pull the suspended armature bias electrode 30 as well as the attached armature 16 towards the substrate bias electrode 22. The contact dimples 24 touch the input line 20 and the output line 18, so the conducting transmission line 28 bridges the gap between the input line 20 and the output line 18, thereby closing the MEM switch.

Loo et al. generally describe a surface micromachined device. That is, layers are deposited on top of a substrate, and then one or more of the layers is etched away to release the moving parts of the switch 10. As described in Loo et al., the parts of the switch generally comprise gold (or gold alloys) for the switch contacts, silicon dioxide for the one or more layers etched away (i.e., the sacrificial layers), and silicon nitride for the beam structural layer. However, the Loo switch generally requires a voltage to be applied to keep the switch in a closed state.

An example of a latching micro switch is described in U.S. Pat. No. 6,496,612 issued Dec. 17, 2002 to Ruan et al. Ruan et al. describe a switch having a cantilever to switch between an open state and a closed state. To operate as a latching switch, a permanent magnet is used to maintain the cantilever in an open state or a closed state. However, the use of a permanent magnet may result in a switch that is bigger and/or heavier than desired. Further, the placement of the permanent magnet further complicates the manufacture of the switch, increasing the cost of the switch.

Another example of a latching switch is described by Xi-Qing Sun, K. R. Farmer and W. N. Carr in "A Bistable Micro Relay Based on Two-Segment Multimorph Cantilever Actuators," The Eleventh Annual International Workshop on Micro-electro Mechanical Systems, 1998, MEMS 98 Proceedings, Jan. 25-29, 1998, pp. 154-159. Sun et al. describe a latching switch mechanism that uses two metals to create stresses in opposite directions along a cantilever beam. RF contacts can be moved by controlling the stress on the two segments electrostatically to lengthen or shorten the length of the cantilever along the substrate so that the contact can be moved from one RF line to another. The fabrication of the switch disclosed by Sun et al. may be complicated since two different metals are required. Further, the latching force is on a direction that may ultimately pull the metal bar from the cantilever.

Therefore, there is a need in the art for small, lightweight latching switch that does not require a constantly applied external voltage or magnetic source to stay latched in a selected state.

SUMMARY

Embodiments of the present invention provide for a method and apparatus for switching that is latchable. An embodiment of the present invention comprises a RF MEMS

metal contact electrostatically actuated latching switch. According to embodiments of the present invention, a cantilever arm is provided that can be moved into orthogonal directions for latching and unlatching. That is, in one orientation, the cantilever arm may be moved in both a horizontal direction and a vertical direction.

Embodiments of the present invention may have a latching structure that essentially comprises a metalized angular mortise and tenon structure. The mortise and tenon structure may be provided by etching a substrate to provide a dovetail structure at the edges of the etched portions of the substrate. The etched edge of the substrate then forms the mortise. The end of the cantilever arm is fabricated to form the tenon. In a latched state, the tenon portion of the cantilever arm fits within the mortise portion of the substrate.

According to some embodiments of the present invention, movement in orthogonal directions may be provided by a combined comb-drive actuator structure and parallel plate actuator structure to move a cantilever arm prior to latching or unlatching. The comb-drive actuator structure provides the capability to move the cantilever arm parallel to the substrate surface. The parallel plate actuator structure provides the capability to move the cantilever arm vertically in a manner similar to that described above for the Loo switch.

BRIEF DESCRIPTION OF THE DRAWINGS

These and other features and advantages will become more apparent from a detailed consideration of the invention when taken in conjunction with the drawings described below. However, this invention may be embodied in many different forms and should not be construed as limited to the embodiments depicted in the drawings or described below. Further, the dimensions of certain elements shown in the accompanying drawings may be exaggerated to more clearly show details. The present invention should not be construed as being limited to the dimensional relations shown in the drawings, nor should the individual elements shown in the drawings be construed to be limited to the dimensions shown.

FIG. 1 (prior art) is a top view of a prior art RF MEMS switches.

FIG. 2A (prior art) shows a cross-sectional view of the switch in FIG. 1 in an open position.

FIG. 2B (prior art) shows a cross-sectional view of the switch in FIG. 1 in a closed position.

FIG. 3 shows a top view of a switch according to an embodiment of the present invention.

FIG. 4 shows a side view of the switch shown in FIG. 3. FIG. 5 illustrates the steps for latching the switch.

FIG. 6 illustrates the components used for calculating the force to laterally move the switch beam illustrated in FIGS. 4 and 5.

FIG. 6A shows a close-up view of a pair of the interdigitated fingers shown in FIG. 6.

FIGS. 7A-7H show steps of a fabrication process for one embodiment according to the present invention.

FIGS. 8A-8D show steps of a fabrication process of an alternative embodiment according to the present invention.

DETAILED DESCRIPTION

It should be appreciated that the particular embodiments shown and described herein are examples of the invention and are not intended to otherwise limit the scope of the present invention in any way. Indeed, for the sake of brevity, conventional electronics, manufacturing, MEMS technolo-

gies and other functional aspects of the systems (and components of the individual operating components of the systems) may not be described in detail herein. Furthermore, for purposes of brevity, embodiments of the invention are frequently described herein as pertaining to a micro electromechanical switch for use in electrical or electronic systems. It should be appreciated that many other manufacturing techniques could be used to create the embodiments described herein. Further, the embodiments according to the present invention would be suitable for application in electrical systems, optical systems, consumer electronics, industrial electronics, wireless systems, space applications, or any other application. Moreover, it should be understood that the spatial descriptions (e.g. "above", "below", up "down", etc.) made herein are for purposes of illustration only, and that embodiments of the present invention may be spatially arranged in any orientation or manner.

A top view of an embodiment of a switch **100** according to the present invention is shown in FIG. 3. FIG. 4 presents a side view of the switch **100** along the center line **4**. The switch **100** comprises a switch beam **150** disposed on a substrate **101**. The substrate **101** preferably comprises semi-insulating GaAs with a {**100**} crystallographic orientation. A portion of the substrate **101** is etched away to provide an etched region **103** in the substrate **101**. If the substrate **101** comprises GaAs, the substrate is preferably etched away with an acidic H₂O₂ solution. A property of this etching solution on the preferred orientation of GaAs is that the wall of the etched GaAs is undercut from the surface to provide a dovetail structure **105** as shown in FIG. 4.

The switch beam **150** is preferably disposed above the etched region **103**. For ease of understanding, the switch **100** can be considered as comprising four parts. The first portion consists of the switch beam **150**, a beam electrode **156** and a substrate electrode **158**. The switch beam **150** preferably comprises at least two structural layers **151**, **152** and one or more metal layers **153**. The at least two structural layers **151**, **152** preferably comprise silicon nitride and the one or more metal layers **153** preferably comprise gold, each 1-2 μm in width. The structural layers **151**, **152** may comprise dielectric materials other than silicon nitride. However, such other dielectric materials should be easily deposited and patterned and have good resistance to the final release etch of the sacrificial layer, discussed below. Silicon nitride is preferred, since it is a material that is commonly used in the semiconductor industry. Materials other than gold, such as aluminum, may be used for the one or more metal layers **153**.

As shown in FIG. 4, the one or more metal layers **153** are configured to provide the beam electrode **156** on or in the switch beam **150**. FIG. 4 shows two structural layers **151**, **152** and a metal layer **153** sandwiched between them. It is preferred that the metal layer **153** be disposed between the upper structural layer **151** and the lower structural layer **152**, so that the structure is more symmetric and less prone to stress caused by thermal expansion mismatch. However, if a thick structure is required, more structural layers **151**, **152** and/or metal layers **153** can be deposited. Further, alternative embodiments may have only the upper structural layer **151** or the lower structural layer **152**.

The beam electrode **156** and the substrate electrode **158** are used to create an electrostatic field to pull the switch beam down **150**. The actuation voltage may be applied to the substrate electrode through substrate electrode actuation pads **159**. The beam electrode **156** may be connected through the switch beam **150** and a spring section **160** (discussed below) to ground pads **157**. Upon application of a voltage to the substrate electrode actuation pads **159**, the

beam electrode **156** will be attracted to the substrate electrode **158**, causing the switch beam **150** to move towards the substrate **101**.

The next part of the switch **100** is where the RF signal is switched. It includes the tip **161** of the switch beam **150**, which comprises a conducting material. Preferably, the conducting material is gold. A metalized mortise **163** is disposed on the dovetail structure **105** formed by the etching of the substrate **101**. The mortise **163** preferably comprises gold that is sputtered on and under the overhanging dovetail structure **105**. Input **167** and output **169** RF lines are disposed on the substrate **101**. The input **167** and output **169** RF lines may be sputtered down and then plated to the desired thickness. A gap **165** in the metalized mortise **163** separates the input **167** and output **169** RF lines. It is preferred that the tip **161** and mortise **163** comprise gold, but other metals or conducting materials that do not easily oxidize may also be used.

The third part of the switch **100** is a switch beam spring **170**. The switch beam spring **170** comprises one or more cross beams **171**, **173** attached to switch beam anchors **175**. The switch beam anchors **175** comprise posts disposed on the substrate **101**. In equilibrium, the spring beam **150** is disposed such that the tip **161** of the switch beam **150** extends beyond the mortise **163**, as shown in FIG. 4. The switch beam spring **170** is preferably fabricated from the same structural layers **151** and metal layers **153** that the switch beam **150** is fabricated from. Therefore, the switch beam spring preferably comprises one or more layers of silicon nitride and one or more layers of gold. A metal line **177** is attached from ground actuation pads **157**, along one of the cross beams **173**, and to the metal layer **153** configured to provide the beam electrode **156**.

The fourth part of the switch **100** is one or more comb-drive actuators **180** consisting of pairs of interdigitated fingers **181**. The fingers **181** preferably comprise the same structural layers **151** and metal layers **153** that the switch beam **150** is fabricated from. One side of the comb-drive actuator **180** is anchored to the substrate **101** by comb actuator posts **188**. One side of the interdigitated fingers **181** are electrically connected to comb-drive actuation electrode pads **187** through the comb actuator posts **188** by metal lines and vias. The other side of the interdigitated fingers **181** is attached to the switch beam spring **170**. The other side of the interdigitated fingers **181** is electrically connected to the ground actuation pads **157** by the metal line **177**.

The steps for latching the switch **100** are described below and are also shown in FIG. 5. Assume the switch is in the equilibrium position shown in FIG. 4. As shown in FIG. 4, the tip **161** of the switch beam **150** is above the metalized mortise **163**. First, a voltage V_L is applied to the comb-drive actuator **180**. The electrostatic force between the interdigitated fingers **181** pulls the switch beam spring **170** and switch beam **150** toward the comb actuator posts **188**, as shown by the arrow **501** in FIG. 5. The switch is fabricated such that the application of voltage V_L will result in the tip **161** of the switch beam **151** being pulled behind the metalized mortise **163**. Then a voltage V_T is applied between beam electrode **156** and the substrate electrode **158**, which causes the switch beam **150** to be pulled down, as shown by arrow **502** in FIG. 5. The switch beam **150** should then rest against the substrate **101** and/or the substrate electrode **158**. The comb-drive actuation voltage V_L is then removed, and the switch beam spring **170** relaxes toward lateral equilibrium, as shown by arrow **503** in FIG. 5. It is prevented from reaching equilibrium when the tip **161** of the switch beam **150** hits the metalized mortise **163**. The metal-metal contact

of the tip **161** of the switch beam **150** and the metalized mortise **163** causes the RF lines **167**, **169** to be electrically connected, hence the switch **100** is closed. The contact force of the switch beam **150** to the metalized mortise **163** is maintained even when the pull down voltage V_T is removed, and the shape of the metalized mortise **163** keeps the switch **100** latched into position.

To unlatch the switch, the voltage V_L is again applied to the comb-drive actuator **180**. The tip **161** of the switch beam **150** will slide out of the metalized mortise **163**, and, because the pull-down voltage is not present, the switch beam **150** will pop up. Removal of the comb-drive actuation voltage then puts the switch beam **150** back into equilibrium where it originated. The gap **165** between the RF lines **167**, **169** is now not connected, so the switch **100** is open.

The viability of this switch can be demonstrated by simple calculations. FIG. 6 illustrates the dimensions of various components used in the calculation of the comb-drive actuator force versus voltage. The calculations discussed below were made based on the use of a pair of interdigitated fingers **181**, as shown in FIG. 6 and shown in a close-up and three-dimensional view in FIG. 6A. The height of each of the interdigitated fingers **181** (i.e. the width of each finger in a direction perpendicular to the surface of the substrate) is assumed to be 5 μm . MEMS switches using a trilayer of silicon nitride/gold/silicon nitride, such as the switch disclosed in U.S. Pat. No. 6,046,659, may have structures with thicknesses of 5 μm . Therefore, the assumption for a similar height for the interdigitated fingers **181** is considered reasonable. The gap between each interdigitated finger **181** is also assumed to be 5 μm .

The formula for the attractive force along the horizontal direction (i.e., the X direction shown in FIG. 5) is:

$$F_x = 0.5 \epsilon_0 V^2 \left(\frac{H}{Z} \right) N$$

where H is the finger height and Z is the finger gap. V is the applied voltage and ϵ_0 is the electric permittivity. N is the number of interdigitated finger surface pairs. If $V=50$ V and $N=201$, the force is $F_x=5.5 \times 10^{-5}$ Newtons. The number of interdigitated finger pairs used for the calculation is considered reasonable, since comb-drive actuators are known in the art that use more than this number.

The lateral displacement may also be determined by reviewing the geometry of the structure depicted in FIG. 5. The switch spring is assumed to be made of silicon nitride, with an elastic modulus of 3×10^{11} Newtons/m². The nitride spring is 400 μm long and 2 μm wide. The lateral displacement may be found by the following equation

$$x = 0.625 F_x L^3 E^{-1} H^{-1} D^{-3}$$

where L is the length of the switch spring, D is the width of the switch spring, and H is the height of the switch spring (the same as for the comb-drive fingers). With the values given, it is found that $x=18.2$ μm , which should be more than enough to pull the end of the spring beam behind the mortise.

The processing of the switch is slightly modified from the current processing practice. The only fabrication differences from the current practice are 1) the first etching step to create the mortise and tenon by etching GaAs to the desired depth, and 2) the dimple etching step is not needed. The layer thickness may be varied depending upon the required latch-

ing forces and desired comb-drive actuator voltages. Additional layers of gold and nitride may also be added to build up the height of the comb-drive fingers to reduce the needed voltage. The use of sputtered gold insures that metal coats the edges of the mortise **163**.

FIGS. 7A-7H illustrate the manufacturing processes embodying the present invention used to fabricate the switch **100** of FIGS. 3 and 4. FIGS. 7A-7H present a profile of the switch taken along the section line 4-4 of FIG. 3. As shown in FIG. 7A, the process begins with a substrate **101**. In a preferred embodiment, GaAs with a {**100**} crystallographic orientation is used as the substrate. Other materials may be used, however, such as InP, ceramics, quartz or silicon. The substrate is chosen primarily based on the technology of the circuitry the MEMS switch is to be connected to so that the MEMS switch and the circuit may be fabricated simultaneously. For example, InP can be used for low noise HEMT MMICS (high electron mobility transistor monolithic microwave integrated circuits) and GaAs is typically used for PHEMT (pseudomorphic HEMT) power MMICS.

FIG. 7B shows a profile of the switch **101** after the etched region **103** is formed. The etch may be performed with acidic (H_2SO_4 or HCl)/hydrogen peroxide etch solutions. As indicated above, the substrate preferably comprises GaAs with a {**100**} crystallographic orientation, since this facilitates the formation of the dovetail structure **105** that facilitates latching.

FIG. 7C shows the deposition of metal for the substrate electrode **158** and the metalized mortise **163**. FIG. 7C also shows the deposition of metal on the substrate to form an electrical contact **198** between one side of the interdigitated fingers **181** and the comb-drive actuation electrode pads **187**. The metal layer may be deposited lithographically using standard integrated circuit fabrication technology, such as resist lift-off or resist definition and metal etch. In the preferred embodiment, gold (Au) is used as the primary composition of the metal layer. Au is preferred in RF applications because of its low resistivity. In order to ensure the adhesion of the Au to the substrate, a 900 angstrom layer of gold germanium is deposited, followed by a 100 angstrom layer of nickel, and finally a 1500 angstrom layer of gold. The thin layer of gold germanium (AuGe) eutectic metal is deposited to ensure adhesion of the Au by alloying the AuGe into the semiconductor similar to a standard ohmic metal process for any III-V MESFET or HEMT.

Next, as shown in FIG. 7D, a support layer **210** is placed on top of the deposited metal and the substrate **101** including the etched region **103**. The support layer **210** typically comprises SiO_2 , which may be sputter deposited or deposited using PECVD (plasma enhanced chemical vapor deposition). The support layer **210** is preferably planarized after being deposited by chemical-mechanical planarizing. Other materials besides SiO_2 may be used as a sacrificial layer **210**. The important characteristics of the sacrificial layer **210** are a high etch rate, good thickness uniformity, and conformal coating by the oxide of the metal already on the substrate **210**. The thickness of the oxide partially determines the thickness of the switch opening, which is critical in determining the voltage necessary to close the switch as well as the electrical isolation of the switch when the switch is open. The sacrificial layer **210** will be removed in the final step to release the switch beam **150** as shown in FIG. 7h.

Another advantage of using SiO_2 as the support layer **210** is that SiO_2 can withstand high temperatures. Other types of support layers, such as organic polyimides, harden considerably if exposed to high temperatures. This makes the polyimide sacrificial layer difficult to later remove. The

support layer **210** is exposed to high temperatures when the silicon nitride for the structural layers **151**, **152** is deposited, as a high temperature deposition is desired when depositing the silicon nitride to give the silicon nitride a lower HF etch rate.

FIG. 7E shows the fabrication of the lower structural layer **152**. The lower structural layer **152** and the upper structural layer **151** (discussed below) are the supporting mechanism of the switch beam **150** and are preferably made out of silicon nitride, although other materials besides silicon nitride may be used. Silicon nitride is preferred because it can be deposited so that there is neutral stress in the structural layers **151**, **152**. Neutral stress fabrication reduces the bowing that may occur when the switch is actuated. The material used for the structural layers **151**, **152** must have a low etch rate compared to the support layer **210** so that the structural layers **151**, **152** are not etched away when the support layer **210** is removed to release the switch beam **150**.

FIG. 7E also shows the etching of the structural layer **152** and the support layer **210** to form recesses **212** for vias for the interdigitated fingers **181** and to provide the comb actuator posts **188**. Those skilled in the art will understand that recesses may also be formed at this step in the process for the switch beam anchors **175** and for vias to provide electrical contact to the other side of the interdigitated fingers **181**. However, these other recesses are not shown in FIG. 7E, due to the cross-section depicted. The structural layer **151** and the support layer **210** may also be etched at this time to form a recess **214** into which metal for the tip **161** will be deposited. The structural layer **152** and the support layer **210** are patterned and etched using standard lithographic and etching processes.

As shown in FIG. 7F, another metal layer **153** is deposited onto the structural layer **152** and into the recesses **212**, **214**. This second metal layer forms the beam electrode **158**. Metal deposited in this step may also form the tip **161** and portions of the interdigitated fingers **181**. In the preferred embodiment, the second metal layer is comprised of a sputter deposition of a thin film (200 angstroms) of Ti followed by a 1000 angstrom deposition of Au. The second metal layer should be conformal across the wafer and acts as a plating plane for the Au. The plating is done by using metal lithography to open up the areas of the switch that are to be plated. The Au is electroplated by electrically contacting the membrane metal on the edge of the wafer and placing the metal patterned wafer in the plating solution. The plating occurs only where the membrane metal is exposed to the plating solution to complete the electrical circuit and not where the electrically insulating resist is left on the wafer. After 2 microns of Au is plated, the resist is stripped off of the wafer and the whole surface is ion milled to remove the membrane metal. Some Au will also be removed from the top of the plated Au during the ion milling, but that loss is minimal because the membrane is only 1200 angstroms thick.

FIG. 7G shows the deposition of the second structural layer **151**. As shown, the second structural layer **151** covers the second metal layer **153** in the area of the beam electrode **156** and also fills in additional portions of the recess **212** to form the comb actuator posts **188**. The second structural layer **152** may also be deposited at this time to form the switch beam anchors **175** (not shown in FIG. 7G). The second structural layer **151** is then lithographically defined and etched to complete the formation of the switch beam spring **170** and the comb-drive actuators. Finally, as shown in FIG. 7H, the support layer **210** is removed to release the switch beam **150**.

If the support layer **210** comprises of SiO₂, then it will typically be wet etched away in the final fabrication sequence by using a hydrofluoric acid (HF) solution. The etch and rinses are preferably performed with post-processing in a critical point dryer to ensure that the switch beam **150** does not come into contact with the substrate **101** when the support layer **210** is removed. If contact occurs during this process, device sticking and switch failure are likely. Contact is prevented by transferring the switch from a liquid phase (e.g. HF) environment to a gaseous phase (e.g. air) environment not directly, but by introducing a supercritical phase in between the liquid and gaseous phases. The sample is etched in HF and rinsed with DI water by dilution, so that the switch is not removed from a liquid during the process. DI water is similarly replaced with ethanol. The sample is transferred to the critical point dryer and the chamber is sealed. High pressure liquid CO₂ replaces the ethanol in the chamber, so that there is only CO₂ surrounding the sample. The chamber is heated so that the CO₂ changes into the supercritical phase. Pressure is then released so that the CO₂ changes into the gaseous phase. Now that the sample is surrounded only by gas, it may be removed from the chamber into room air.

The fabrication of an alternative embodiment according to the present invention is depicted in FIGS. **8A-8D**. As indicated above, it is preferred that the fingers of the interdigitated fingers **181** have a thickness of at least 5 μm so that the lateral electrostatic voltage V_L is kept to around 50V or less. However, as discussed above and shown in FIG. **7F**, the metal for the interdigitated finger **181** can be deposited at the same time as the metal for the beam electrode **156**. If the metal layer for the beam electrode **156** is 5 μm, the switch beam will become thicker and may become stiffer and more difficult to pull down. Hence, the process shown in FIGS. **7A-7H**, may require one to choose between a lower lateral electrostatic voltage V_L and a higher transition voltage V_T between the beam electrode **156** and the substrate electrode **158**, or a higher lateral electrostatic voltage V_L and a lower transition voltage V_T. FIGS. **8A-8D** depict the fabrication of an embodiment in which the interdigitated fingers **181** may have a different thickness than the beam electrode **156**.

FIG. **8A** depicts a process step similar to that shown in FIG. **7F**, in which metal is deposited to form the beam electrode **156** and the tip **161**. However, in this step, the metal for the interdigitated fingers is not yet deposited. FIG. **8B** depicts another metal deposition step, in which the gold (or other electrically conductive material) for the interdigitated fingers is deposited with a metal layer thicker than that used to form the beam electrode **156**. As discussed above, a preferred thickness for the interdigitated fingers is 5 μm. FIGS. **8C** and **8D** depict process steps similar to those depicted in FIGS. **7G** and **7H**, in which the upper structural layer **151** is deposited and patterned and the support layer **210** is removed to release the switch beam **150**. As shown in FIG. **8D**, the metal layer **153** for the interdigitated finger **181** is thicker than the metal layer **153** for the beam electrode **156**.

As can be surmised by one skilled in the art, there are many more configurations of the present invention that may be used other than the ones presented herein. It is therefore intended that the foregoing detailed description be regarded as illustrative rather than limiting and that it be understood that it is the following claims, including all equivalents, that are intended to define the scope of this invention.

What is claimed is:

1. A micro-electro-mechanical switch comprising a substrate, wherein the substrate has at least one recess with a tip receiving structure;
 - a cantilever structure disposed on the substrate, wherein the cantilever structure has a cantilever structure tip adapted to fit into the tip receiving structure;
 - a horizontal actuator having a cantilever horizontal actuator portion coupled to the cantilever structure and a substrate horizontal actuator portion disposed on the substrate; and
 - a vertical actuator having a cantilever vertical actuator portion disposed on the cantilever structure and a substrate vertical actuator portion disposed on the substrate.
2. The micro-electro-mechanical switch of claim 1, wherein the cantilever structure comprises:
 - a switch beam spring disposed on the substrate; and
 - a switch beam coupled to the switch beam spring, wherein the switch beam spring is configured to allow the switch beam to move in a direction generally parallel to the substrate.
3. The micro-electro-mechanical switch of claim 2, wherein the horizontal actuator comprises:
 - a comb-drive actuator having a plurality of pairs of interdigitated electrode fingers, wherein each pair of interdigitated electrode fingers has a substrate actuator finger and a cantilever actuator finger, and
 - the substrate horizontal actuator portion comprises:
 - one or more comb actuator posts disposed on the substrate, and
 - the substrate actuator fingers, wherein each substrate actuator finger extends from one of the one or more comb actuator posts, and
 - the cantilever horizontal actuator portion comprises:
 - the cantilever actuator fingers, wherein each cantilever actuator finger extends from the switch beam spring.
4. The micro-electro-mechanical switch of claim 1 wherein the tip receiving structure comprises a transition between the at least one recess and an upper surface of the substrate, wherein the upper surface of the substrate projects over an upper surface of the at least one recess at the transition, and the switch further comprises:
 - an input line;
 - an output line;
 - an input mortise electrically connected to the input line, wherein the input mortise comprises conducting material disposed on a portion of the transition between the at least one recess and the upper surface of the substrate;
 - an output mortise electrically connected to the output line, wherein the output mortise comprises conducting material disposed on a portion of the transition between the at least one recess and the upper surface of the substrate,
 wherein the input mortise is separated from the output mortise by a gap with no conducting material in the transition between the at least one recess and the upper surface of the substrate, and the cantilever structure tip comprises conducting material sized to span the gap and electrically connect the input mortise to the output mortise.
5. The micro-electro-mechanical switch of claim 2, wherein the cantilever vertical actuator portion comprises a switch beam electrode disposed on the switch beam and the substrate vertical actuator portion comprises a substrate electrode disposed to attract the switch beam electrode

11

towards the substrate when a voltage is applied between the switch beam electrode and the substrate electrode.

6. The micro-electro-mechanical switch of claim 5, wherein the switch beam comprises one or more upper switch beam layers and one or more lower switch beam layers and the switch beam electrode is disposed between one or more upper switch beam layers and the one or more lower switch beam layers.

7. The micro-electro-mechanical switch of claim 6, wherein the upper switch beam layers and/or the lower switch beam layers comprise silicon nitride.

8. The micro-electro-mechanical switch of claim 5, wherein the switch beam electrode and/or the substrate electrode comprise gold.

9. The micro-electro-mechanical switch of claim 1, wherein the substrate comprises GaAs with a {100} crystallographic orientation.

10. The micro-electro-mechanical switch of claim 2, wherein the switch beam spring comprises one or more layers of silicon nitride.

11. A method of switching comprising:

providing a cantilever structure coupled to a substrate by a spring structure, wherein the cantilever structure has at least a portion of the cantilever structure adapted to move generally parallel to a surface of the substrate and move generally perpendicular to the surface of the substrate;

applying a first voltage to move the at least a portion of the cantilever structure in a first direction parallel to the surface of the substrate by a first electrostatic attractive force;

after applying the first voltage, applying a second voltage to attract the at least a portion of the cantilever structure towards the surface of the substrate by a second electrostatic attractive force;

after applying the second voltage, removing the first voltage and having the at least a portion of the cantilever structure move in a direction generally opposite to the first direction due to a horizontal spring force from the spring structure; and

after removing the first voltage, capturing a tip of the cantilever structure in a receiving structure provided in or on the substrate.

12. The method of claim 11, wherein the spring structure comprises a horizontal spring portion and a vertical spring portion, the horizontal spring portion applying the horizontal spring force in a direction opposite to the first electrostatic attractive force and the vertical spring portion applying a vertical spring force in a direction opposite the second electrostatic attractive force.

13. The method of claim 11 further comprising: removing the second voltage, wherein the cantilever structure is held in place by the tip captured in the receiving structure.

14. The method of claim 13 further comprising: after capturing the tip of the cantilever structure in a receiving structure provided in or on the substrate,

12

applying a third voltage to move the at least a portion of the cantilever structure in the first direction parallel to the surface of the substrate by a third electrostatic attractive force; and

removing the second voltage either before or after applying the third voltage.

15. The method of claim 11, wherein the tip of the cantilever structure comprises electrically conducting material and the receiving structure comprises: an input conducting material portion, an output conducting material portion, and a nonconducting gap disposed between the input conducting material portion and the output conducting material portion, and the tip of the cantilever structure spans the nonconducting gap to provide an electrical connection between the input conducting material portion and the output conducting material portion when the tip of the cantilever structure is captured in the receiving structure.

16. A micro-electro-mechanical switch comprising

a substrate;

a cantilever structure coupled to the substrate, the cantilever structure having a first end and a second end;

means for providing movement in a first vertical direction of the second end of the cantilever structure, the means for providing movement in a first vertical direction disposed at or near the first end of the cantilever structure;

means for providing movement in a first horizontal direction of the second end of the cantilever structure, the means for providing movement in a first horizontal direction disposed at or near the first end of the cantilever structure;

means for providing movement in a second vertical direction of the second end of the cantilever structure, the second vertical direction opposite to the first vertical direction;

means for providing movement in a second horizontal direction of the second end of the cantilever structure, the second horizontal direction opposite to the first horizontal direction; and

means for capturing the second end of the cantilever structure when the second end of the cantilever structure is moved towards the substrate.

17. The micro-electro-mechanical switch of claim 16 further comprising switch conductive means disposed on the second end of the cantilever structure and the means for capturing further comprises an input conductive means, an output conductive means, and a nonconductive means separating the input conductive means and the output conductive means, wherein the switch conductive means electrically connects the input conductive means to the output conductive means when the second end is captured in the means for capturing.

* * * * *