

J. C. DONNELLY.
MATCH MAKING MACHINE.

No. 553,609.

Patented Jan. 28, 1896.

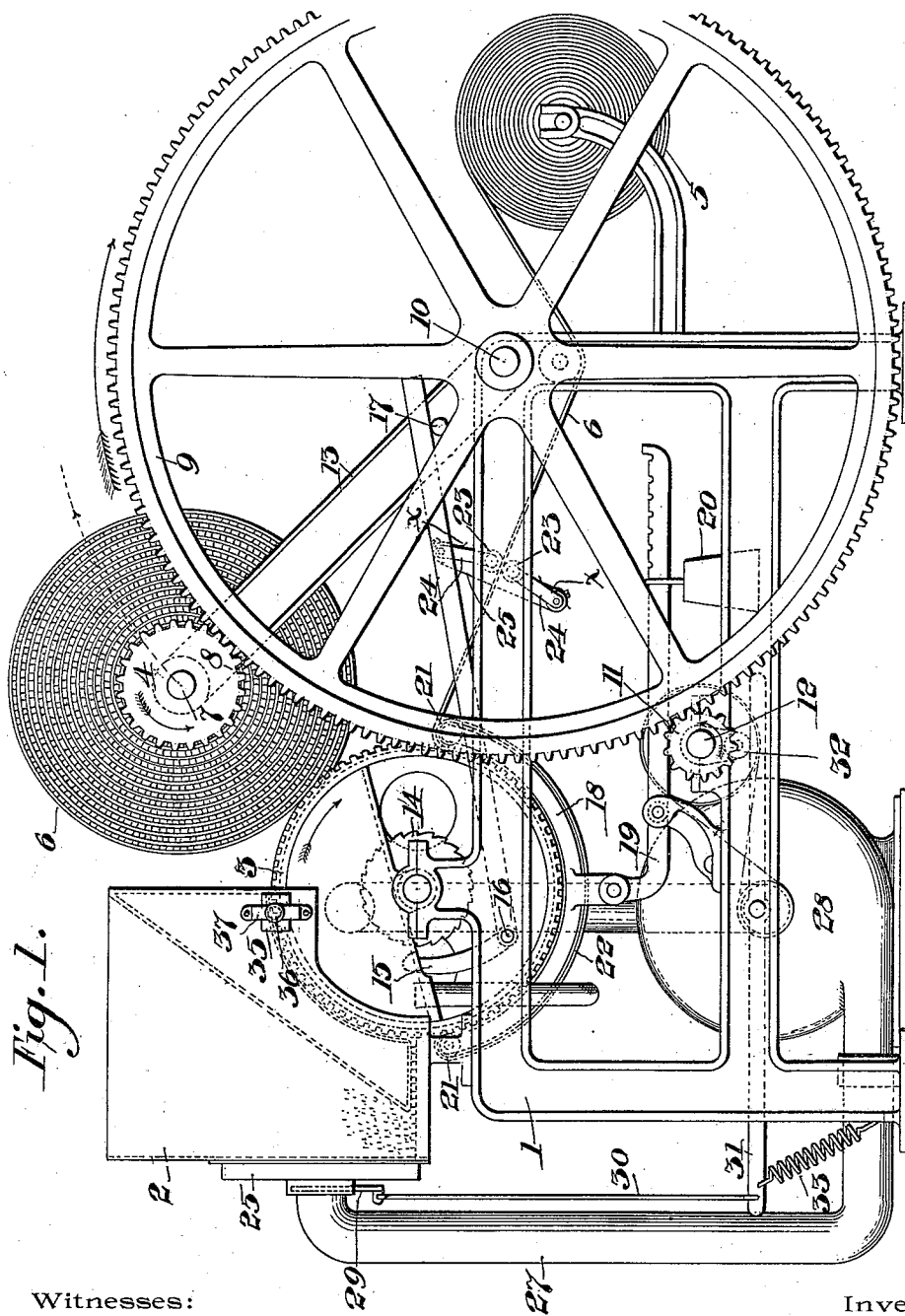

Fig. 1.

Witnesses:

Jesse B. Heller.
Isaac Heller.

Inventor.

Joseph C. Donnelly
per John F. Nolan

Attorney.

J. C. DONNELLY.
MATCH MAKING MACHINE.

No. 553,609.

Patented Jan. 28, 1896.

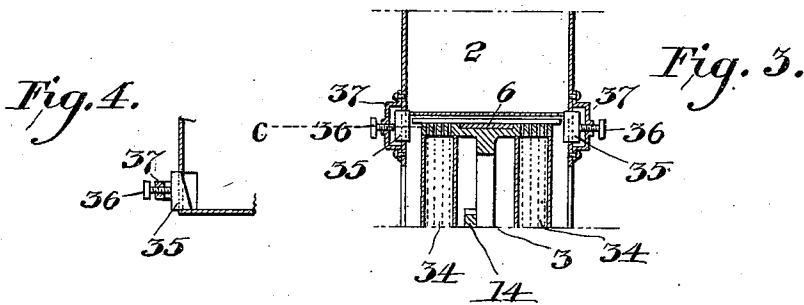
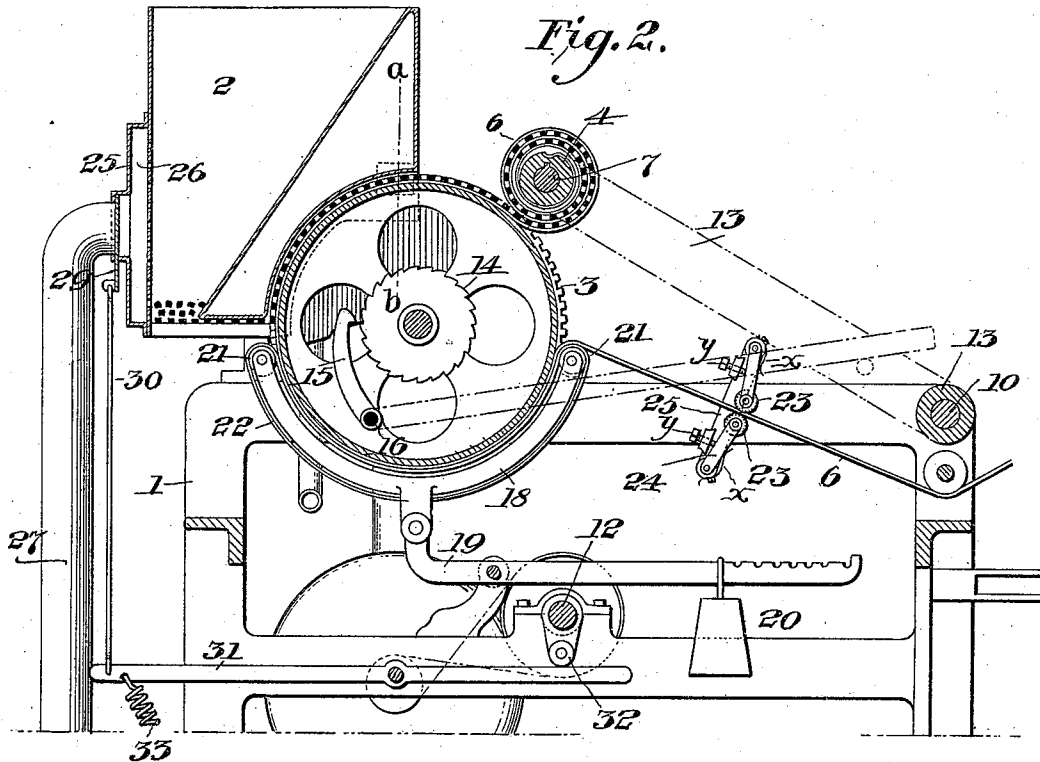

Witnesses:

Jose B. Heller
Irma S. Heller

Inventor.

Joseph C. Donnelly
Per John P. Nolan

Attorney.

UNITED STATES PATENT OFFICE.

JOSEPH C. DONNELLY, OF PHILADELPHIA, PENNSYLVANIA.

MATCH-MAKING MACHINE.

SPECIFICATION forming part of Letters Patent No. 553,609, dated January 28, 1896.

Application filed February 24, 1894. Serial No. 501,329. (No model.)

To all whom it may concern:

Be it known that I, JOSEPH C. DONNELLY, a citizen of the United States, residing in the city and county of Philadelphia and State of Pennsylvania, have invented certain new and useful Improvements in Match-Making Machines, of which the following is a full, clear, and exact description, reference being had to the accompanying drawings, forming a part of this specification.

This invention relates to match-making machines of that class, more especially, wherein the splints are conducted from a hopper to a bunching device.

The objects of the invention are, first, to provide a construction in which the bunching spool or coil shall be positively actuated and the movement of the feed-roller shall be progressively varied proportionately to the increasing size of the coil; secondly, to provide means whereby the action of the feed-roller shall be arrested when the coil has reached a predetermined size; thirdly, to provide devices for applying tension to the bunching-web on its passage from the reel to the bunching-spool, and, fourthly, to provide a means to effect the agitation of the splints contained in the hopper.

With these objects in view the invention comprehends various novel features of construction and organization of parts that will be hereinafter fully described and be definitely claimed.

Referring to the drawings, Figure 1 is a side elevation of a machine embodying the invention. Fig. 2 is a longitudinal vertical section thereof. Fig. 3 is a sectional detail of the hopper and its adjuncts, as on the line *a b* of Fig. 2. Fig. 4 is a section as on the line *c* of Fig. 3.

The numeral 1 represents the main framework, upon which are supported the hopper 2, the feed-roller 3, the bunching device 4, the web-reel 5, and the web 6, from which the reel passes under and around the feed-roller to the bunching-spool.

The feed-roller is peripherally serrated transversely to take up the splints from the hopper, and it is grooved circumferentially to receive the bunching-web. Instead of this wheel being positively driven by toothed gearing, as ordinarily, it is mounted loosely on its

shaft in such manner that it will be impelled by and only by the web as the latter is drawn to and wound upon the bunching-spool. Hence as the coil increases in size a greater quantity of the web will be taken up during each succeeding revolution of the spool, and, in consequence, the speed of the roller will be relatively increased. Where the feed-roller is positively driven at a uniform rate of speed it is necessary to provide with friction connections the driving devices for the bunching-spool, to the end that such connections will slip or give as the coil increases in size. By my construction I am enabled to dispense with the slipping devices, and, therefore, I actuate the bunching-spool positively and not conditionally—that is to say, I fix on the end of the stud 7, upon which the spool is mounted, a pinion 8, with which engages a spur-wheel 9 on the shaft 10, which wheel is driven by a gear 11 on a driving-shaft 12. The shaft 10 to which the spur-wheel is fixed is the shaft upon which is supported the lower end of the usual vibratory spool-supporting arm 13, so that as the arm gradually swings outward, during the splint-bunching operation, the pinion will remain in engagement with the wheel.

As a simple and efficient means to arrest the feeding of the splints to the machine when the coil has reached a given size, I provide the feed-roller with a ratchet-wheel 14, with which is adapted to coact a pawl 15 adjacent thereto. This pawl, in the present instance, is the shorter arm of a lever that is fulcrumed on a stud 16 on the side of the framework, the longer arm of the lever extending rearwardly beyond and laterally of the arm 13. On this arm is a stud or projection 17, upon which the longer arm of the lever is supported during the coiling operation, the tooth of the pawl in that case being held out of action with the ratchet-wheel; but when, or about when, the coiling operation has been completed the stud 17 swings beyond the free end of the lever-arm, which arm, thereupon dropping, throws the pawl into engagement with the ratchet-wheel. This done, the forward movement of the feed-roller is checked and, in consequence, the feeding of the splints is arrested.

It will be obvious that in lieu of the ratchet-

and-pawl mechanism just described various other trip devices may be employed to stop the feed-roller.

In order to apply sufficient friction to the web so that the latter will be wound upon the spool under considerable tension, I dispose below the feed-roller a segmental shoe 18, which is pivotally connected with the shorter arm of a lever 19, the longer arm of which is provided with an adjustable weight 20. The web is passed between the shoe and the groove of the feed-roller, so that the pressure exerted by the weight will tend to maintain the shoe forcibly against the web, and thus clamp the latter against the roller. I preferably equip the ends of the shoe with friction-rollers 21, around which passes an endless band 22, the function of which is to take against the web and prevent undue wear thereof by the otherwise unyielding pressure of the shoe.

To impart additional tension to the web, I mount in advance of the feed-roller a pair of clamping-rollers 23, between which the web passes. These rollers are supported on the free ends of arms 24 that are pivoted to a bracket 25, extending from the side of the framework, the arms being inclined rearwardly, as seen, so that the web during its onward traverse will tend to draw the rollers together similarly to a toggle-joint, and thus effect the end in view.

Suitably-disposed springs x tend to maintain the arms in active position. As a means to regulate the tension exerted by the rollers 23 upon the web, I provide set-screws y to limit the forward movement of the arms.

In view of the fact that the bunching-spool is positively driven, as above described, a much greater tension of the web is permissible than if the spool were conditionally driven as heretofore, and hence a tighter and more efficient winding of the web upon the spool is insured.

For the purpose of agitating the splints in the hopper to insure their free passage to the feed-roller I perforate one wall of the hopper, preferably the back, and fix on the perforated surface a shallow casing 25 to form a chamber 26 that connects the series of perforations. Communicating with this chamber is a pipe 27 leading from the mouth of a fan 28, or other air-blast device, whereby the air-current will be forced into and throughout the interior of the hopper. To render the current intermittent I provide the pipe at a suitable point with a gate or damper 29, which is connected by means of a link 30 with one arm of a lever 31, the other arm of which extends below the driving-shaft of the machine. On this shaft is a cam 32 that acts upon the opposed lever-arm to depress the same and thus close the gate or valve 29. A suitably-arranged spring 33 tends normally to draw down the shorter arm of the lever, and hence during the rotation of the driving-shaft the gate is alternately opened and closed.

The fan may be utilized to exhaust the air

from chambers 34 that communicate with peripheral perforations in the feed-roller, the suction thereby induced being designed to draw and maintain the splints upon the roller. This suction feature is embraced in a pending application for Letters Patent.

As a means to adjust the splints upon the feed-roller so that they will be conducted uniformly to the bunching-spool I fit in the inner sides of the forward portion of the hopper a pair of blocks 35, the inner edges of which are beveled, as seen in Fig. 4. Set-screws 36 working in brackets 37 on the respective sides of the hopper are provided to effect the adjustment of the blocks as occasion may require.

I claim as my invention—

1. In a machine for coiling match splints, in combination with the coiling devices and the feeding device from which the splints are transferred to the coiler, means for stopping the motion of the feeding device without stopping the coiling devices, substantially as described.

2. In a machine for arranging match-splints for treatment, in combination with a source of supply of the splints, and the splint receiving and holding devices, a feeding device to deliver the splints from the source of supply to such receiving and holding devices, adapted to be stopped independently of the latter, and means for holding it from movement, substantially as described.

3. In a match bunching machine, the combination, with the freely-rotatable feed roller, or carrier, the bunching spool, its supporting and operating parts, and the web co-acting with said roller or carrier and spool, of a stop device adapted to act directly on the said roller or carrier to fix the latter or check its rotation, and means whereby said device is automatically actuated when the coil has reached a predetermined size, substantially as described.

4. In a match bunching machine, the combination of the freely rotatable roller or carrier, the bunching spool, its supporting and operating parts, and the web co-acting with said roller, or carrier, and spool, of a stop device adapted to act on the said roller or carrier, a stop lever connected with said device, and means on the spool support for tripping said lever when the coil of splints has reached a predetermined size, substantially as described.

5. In a match bunching machine, the combination of the freely rotatable feed roller or carrier, the bunching spool, its supporting and operating parts, and the web co-acting with said roller, or carrier, and spool, of a ratchet wheel on said roller, a pawl adjacent thereto, a lever connected with said pawl, and means on the spool support for tripping said lever to engage the pawl with the ratchet wheel when the coil of splints has reached a predetermined size, substantially as described.

6. In a match bunching machine, the combination of the freely rotatable feed roller or

carrier, the bunching spool, the vibratory supporting arm therefor, means for rotating said spool, and the web co-acting with said roller, or carrier, and the spool, of a ratchet wheel on said roller or carrier, a pawl adjacent thereto, a lever connected with said pawl, and a pin or projection on the said arm adapted to support and trip the lever at certain stages of the bunching operation, substantially as described.

7. The combination with the feed roller or carrier, the bunching spool, its supporting and operating parts, and the web co-acting with said roller or carrier and the spool, of a pair of oppositely inclined pivoted arms, friction wheels thereon between which the web extends, and stops for said arms, substantially as described.

8. The combination with the feed roller or carrier, the bunching spool, its supporting and operating parts, and the web co-acting with said roller or carrier and the spool, of a pair of oppositely-inclined pivoted arms, friction wheels thereon between which the web extends, and adjustable stops for said arms, substantially as described.

9. The combination with the splint-containing hopper, of means for injecting a blast of air into the same for the purpose of agitating the splints, substantially as described.

10. The combination of a splint-containing hopper, of means for intermittently injecting blasts of air into the same for the purpose of

agitating the contained splints, substantially as described.

11. The combination with the splint-containing hopper provided with a perforated wall, of a pipe communicating with the perforations in said wall, and a fan or air engine connected with said pipe, substantially as described.

12. The combination with the splint-containing hopper provided with a perforated wall, of a pipe communicating with the perforations in said wall, a fan or air engine connected with said pipe, a gate or valve in the latter, and means for reciprocating said gate or valve, substantially as described.

13. The combination with the splint-containing hopper provided with a perforated wall, of a pipe communicating with the perforations in said wall, a fan or air engine connected with said pipe, a normally open gate or valve in the latter, a lever connected with said gate or damper, a shaft, and a cam thereon adapted to actuate said lever at intervals to open the gate or valve, substantially as described.

In testimony whereof I have hereunto affixed my signature in the presence of two subscribing witnesses.

JOSEPH C. DONNELLY.

Witnesses:

JOHN R. NOLAN,
IRA S. HELLER.