



US 20020046901A1

(19) **United States**

(12) **Patent Application Publication**  
**Zapfe**

(10) **Pub. No.: US 2002/0046901 A1**

(43) **Pub. Date: Apr. 25, 2002**

(54) **NOISE CANCELLATION USING A MECHANICAL OSCILLATOR**

(52) **U.S. Cl. .... 181/206; 181/207**

(76) **Inventor: Jeffrey A. Zapfe, Cambridge, MA (US)**

(57) **ABSTRACT**

Correspondence Address:  
**WEINGARTEN, SCHURGIN, GAGNEBIN & LEBOVICI LLP**  
**TEN POST OFFICE SQUARE**  
**BOSTON, MA 02109 (US)**

A system and method for the reduction of noise radiated by a vibrating structure at a given frequency are disclosed. In systems of the invention, a radiation-cancelling device that acts like a resiliently supported mass with a significant sound radiating area is attached to the exterior surface of the structure to be quieted. Radiation from such a device, when constructed so that the motion of the vibrating structure provides the driving frequency for oscillation of the spring-mass system in the radiation-cancelling device and so that the natural frequency of the spring-mass system in the radiation-cancelling device is lower than the vibration frequency of the vibrating structure cancels the sound radiating from the (preferably) considerably larger vibrating surface to which it is attached. If appropriate, more than one radiation-cancelling device may be attached to a given vibrating structure in a system according to the invention.

(21) **Appl. No.: 09/940,070**

(22) **Filed: Aug. 27, 2001**

**Related U.S. Application Data**

(63) **Non-provisional of provisional application No. 60/227,814, filed on Aug. 25, 2000.**

**Publication Classification**

(51) **Int. Cl.<sup>7</sup> ..... F01N 1/06**

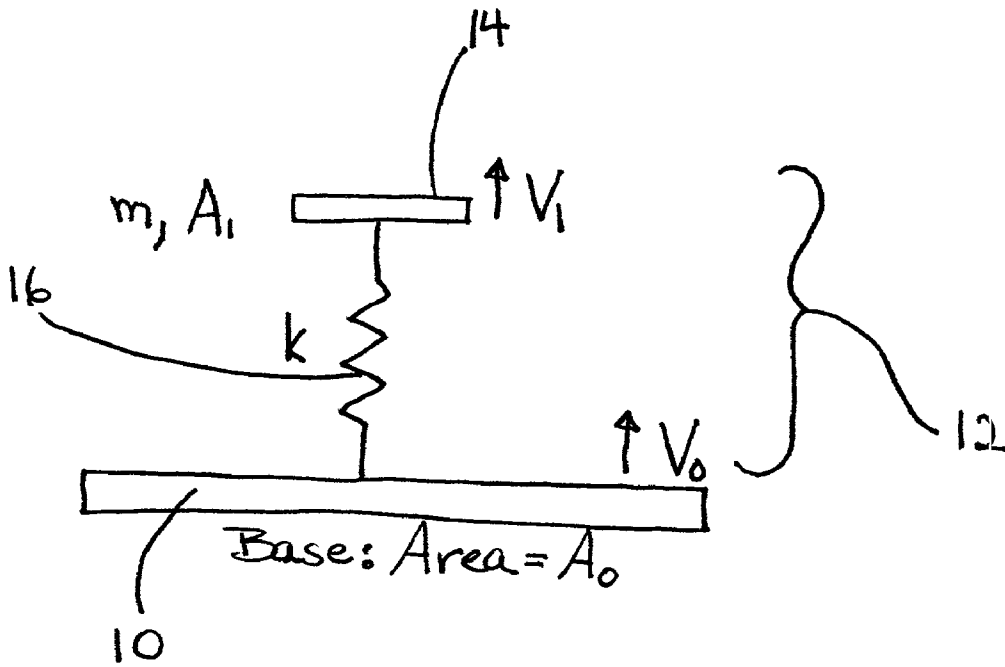

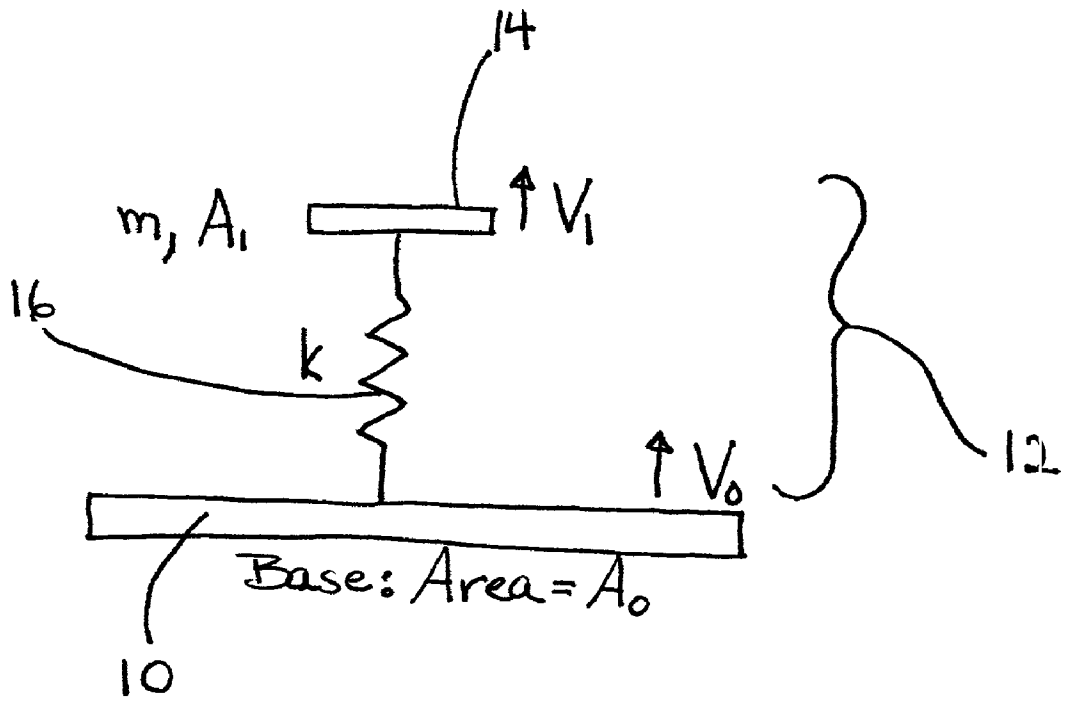

Fig. 1

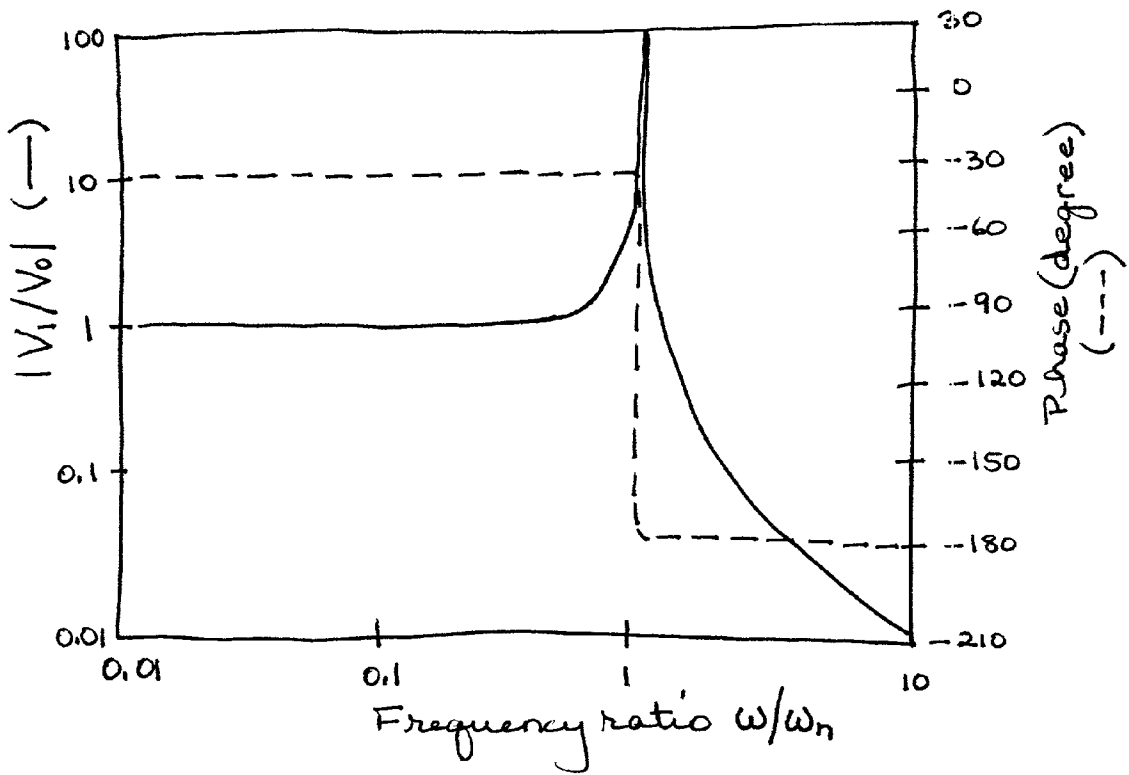

Fig. 2

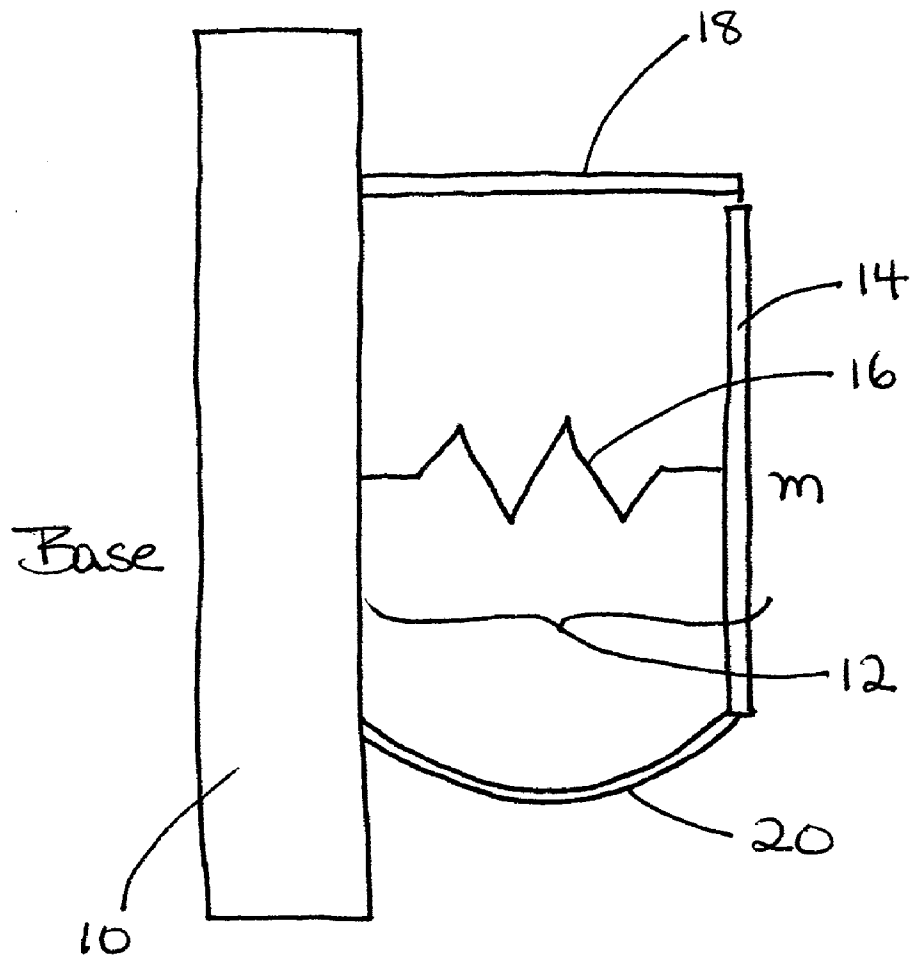

Fig. 3

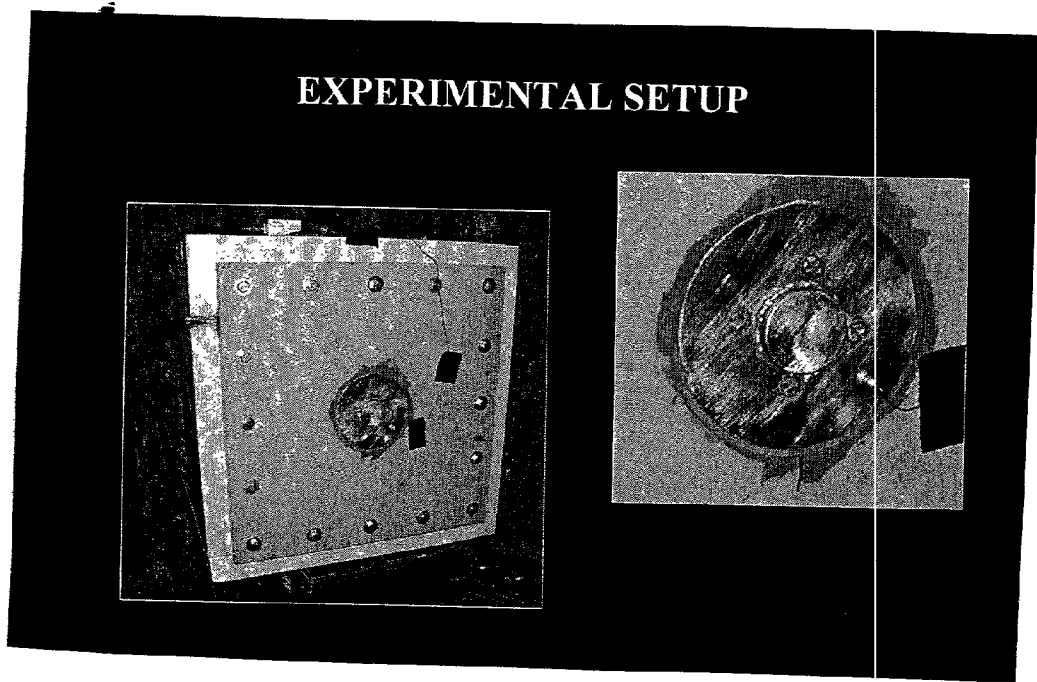

Fig. 4

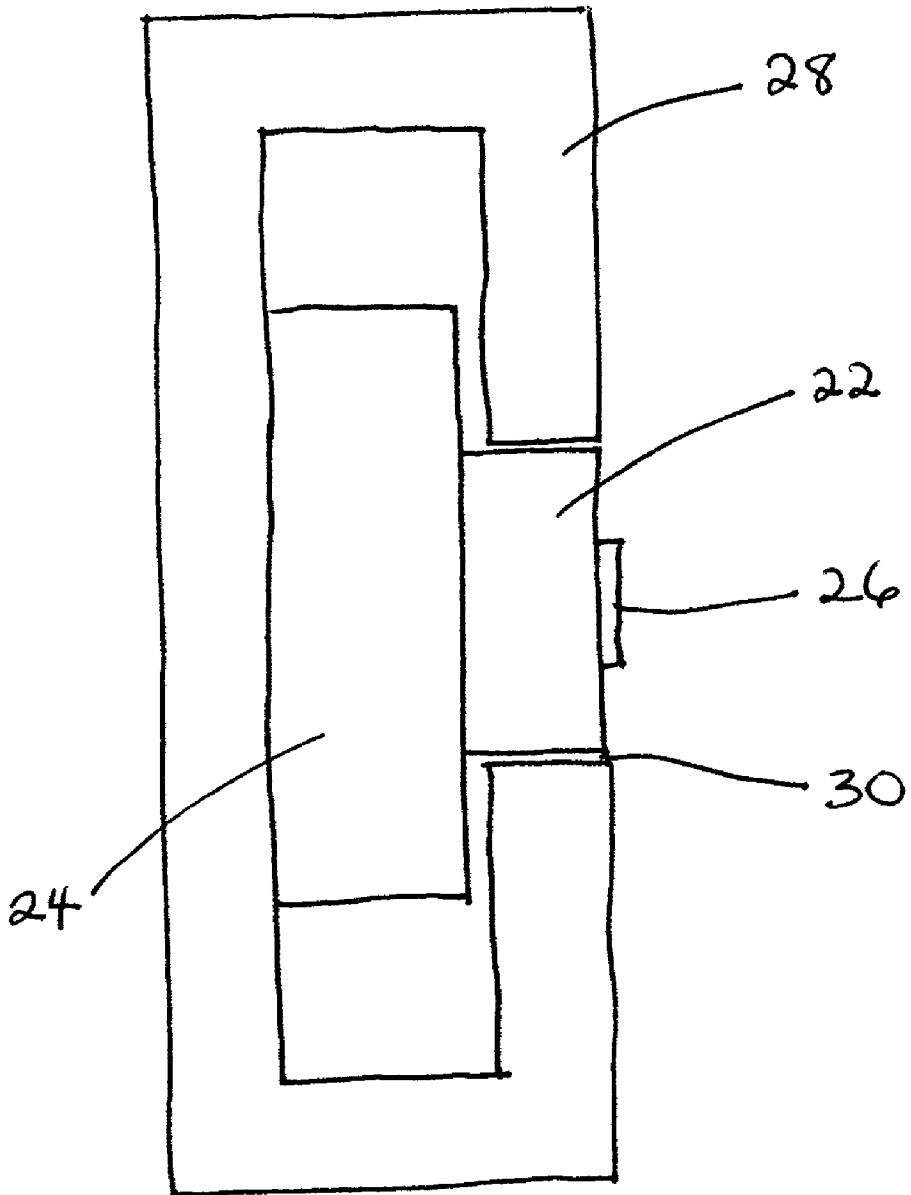

Fig. 5

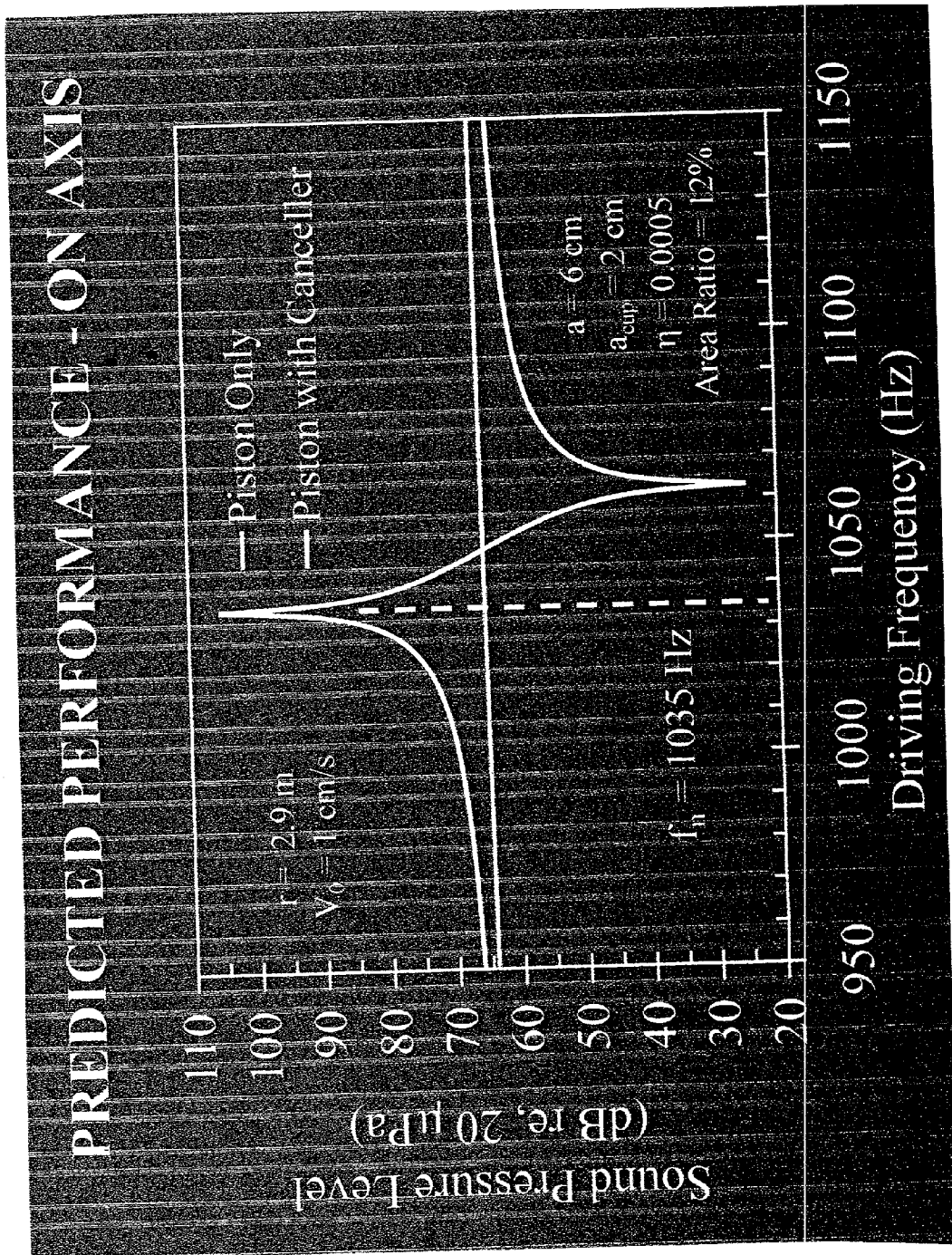

Fig. 6

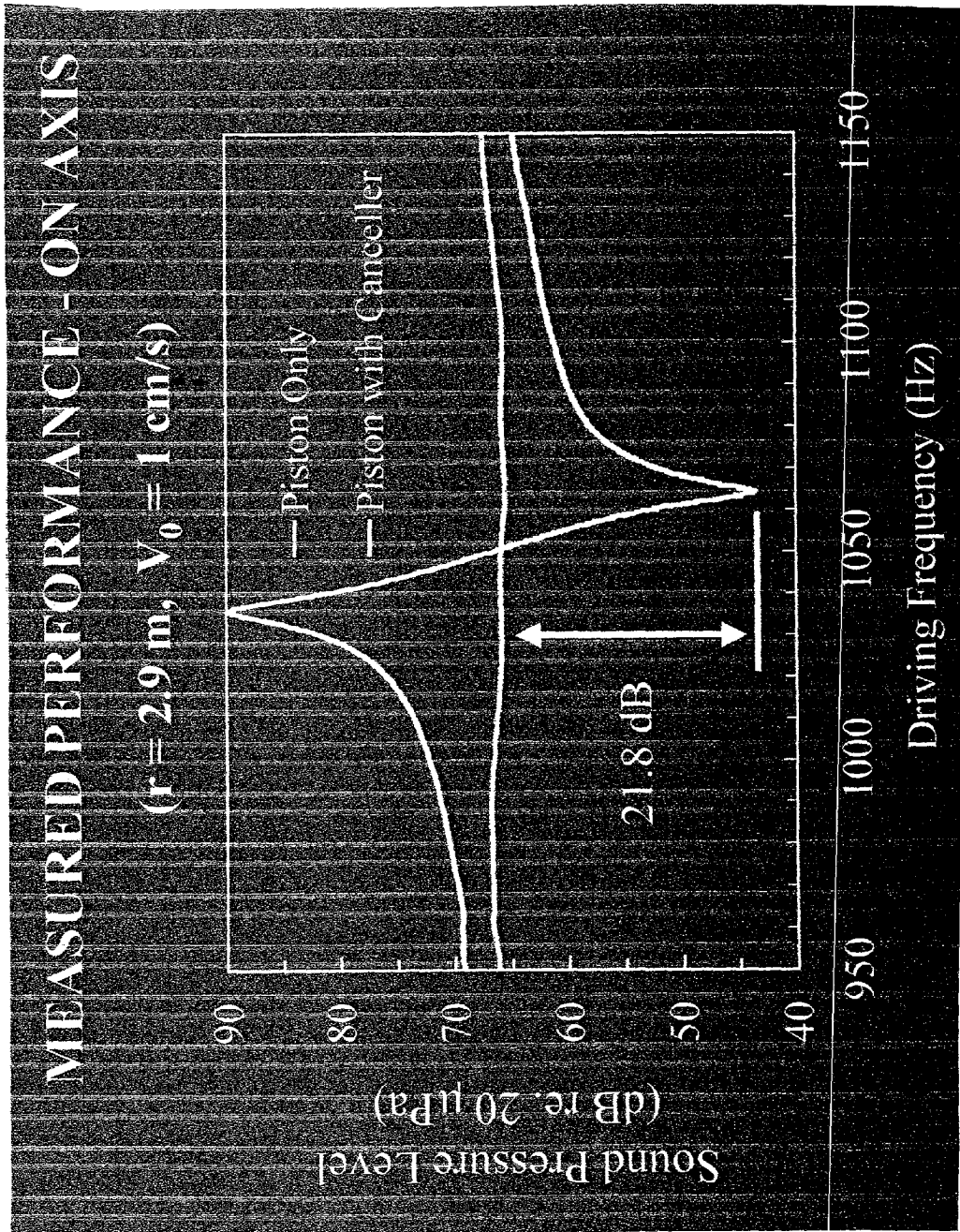

Fig. 7



## NOISE CANCELLATION USING A MECHANICAL OSCILLATOR

### CROSS REFERENCE TO RELATED APPLICATIONS

[0001] This application claims the priority of U.S. Provisional Application No. 60/227,814 filed Aug. 25, 2000 entitled, NOISE CANCELLATION USING A MECHANICAL OSCILLATOR, the whole of which is hereby incorporated by reference herein.

### BACKGROUND OF THE INVENTION

[0002] Machines or equipment, when in operation, often vibrate sufficiently to generate a significant amount of noise. This noise can be of a sufficient volume or of a tone quality to interfere with surrounding activities. When one wants to reduce the noise radiated from such a vibrating structure, one usually first considers reducing the vibrations responsible for the noise radiation. This may involve modification of the basic sources of the vibrations, reducing the transmission of vibrations from the primary sources to the radiating surfaces of the structure (by design changes and/or adding isolation devices, such as resilient gaskets), and/or increasing the structural damping of the vibrating surfaces (by the addition of damping treatments, typically including layers of energy-dissipating "viscoelastic" materials.) Noise reduction attempts may also involve reconfiguring the vibrating surfaces so as to make them less efficient sound radiators (for example, by modifying their ribs and edge-connections.) All of the foregoing typically involve changes in the basic design, which generally are costly and often may interfere with the basic function of the item under consideration.

[0003] In many situations, these types of approaches cannot be implemented readily. In that case, one typically needs to consider "lagging" the radiating surfaces—that is, covering each such surface with a resilient layer (perhaps of soft fiberglass mat), on top of which is placed a massive layer (a steel plate, lead sheet, or sheet of leaded vinyl, for example). Lagging is one type of barrier system through which sound is transmitted relatively poorly. Other barrier arrangements consist of (partial or full) enclosures and of sound barrier walls (which, in fact, are partial enclosures). These types of approaches, however, tend to interfere with cooling and ventilation, may require considerable space, and often are unsightly.

[0004] Recently, so-called active noise cancellation systems have been developed. These, in essence, use one or more microphones to sense the radiated sound, one or more added sound sources, e.g., a loudspeaker, and control systems that cause the sound sources to produce sound that cancels the unwanted noise. Active systems typically are complex, expensive and relatively unreliable. Thus, new methods of reducing noise from a vibrating structure would clearly be desirable.

### BRIEF SUMMARY OF THE INVENTION

[0005] A mechanical oscillator that in concept consists of a spring-supported mass has a natural frequency that is directly proportional to the square root of the stiffness of the spring and inversely proportional to the square root of the mass. If such an oscillator is now affixed to a structure that

vibrates at a frequency that is higher than the natural frequency of the oscillator, then the motion of the oscillator mass driven by that structure is opposite to the direction of motion of the structure (i.e., opposite in phase). Furthermore, at frequencies near the natural frequency of the oscillator, the excursions of the mass of the oscillator will be larger than those of the structure. Such an oscillator, if it is an efficient radiator of sound, can cancel sound produced by the vibrating structure.

[0006] In general, the invention is directed to the application of the above principles to the reduction of noise radiated by a structure at a given frequency. In systems of the invention, a radiation-cancelling device that acts like a resiliently supported mass with a significant sound radiating area is attached to the exterior surface of the structure to be quieted. Radiation from such a device, when properly constructed as describe herein, i.e., if the natural frequency and sound radiation characteristics of the mass are selected appropriately, cancels the sound radiating from the (preferably) considerably larger vibrating surfaces to which it is attached. If appropriate, more than one radiation-cancelling device may be attached to a given vibrating structure in a system according to the invention.

[0007] The radiation-cancelling device, or oscillator, need not consist of separate spring and mass elements. It may consist, for example, of a circular plate that is rigidly connected at its midpoint to the vibrating structure. In this configuration, the plate serves as both the spring and the mass. In another configuration, the oscillator can be configured to resemble an inverted metal cup where the sides of the cup substantially serve the function of a spring. Radiation-cancelling devices according to the invention are useful for reducing the sound radiation from equipment items, such as transformers, which vibrate and radiate noise at a fixed frequency.

### BRIEF DESCRIPTION OF THE DRAWINGS

[0008] Other features and advantages of the invention will be apparent from the following description of the preferred embodiments thereof and from the claims, taken in conjunction with the accompanying drawings, in which:

[0009] **FIG. 1** is a schematic rendering of a system according to the invention;

[0010] **FIG. 2** is a graph showing relative movement of a vibrating structure and an attached radiation-cancelling device at various ratios of the driving frequency of the vibrating structure to the natural frequency of the radiation-cancelling device;

[0011] **FIG. 3** is a schematic representation of two methods of reducing noise radiating from the underside of the radiation-cancelling device;

[0012] **FIG. 4** is a photograph of an experimental system according to the invention;

[0013] **FIG. 5** is a diagrammatic representation of the system of **FIG. 4**;

[0014] **FIG. 6** is a graph showing the predicted on-axis performance of the system of **FIG. 4**; and

[0015] **FIG. 7** is a graph showing the measured on-axis performance of the system of **FIG. 4**.

DETAILED DESCRIPTION OF THE  
INVENTION

[0016] A system according to the invention provides a passive means for cancellation of undesirable radiated noise tones from a vibrating structure such as a transformer. Referring to FIG. 1, a vibrating structure can be represented as a base 10 having area  $A_0$  and velocity amplitude  $V_0$ . An oscillating radiation-cancelling device 12 according to the invention, to be used to reduce noise from the vibrating structure, includes, in basic concept, a body 14 of mass  $m$ , which is attached to the structure base 10 by a spring 16, having spring constant  $k$ . Body 14 is represented as having area  $A_1$  and velocity amplitude  $V_1$ .

[0017] Now, referring to FIG. 2, consider the behavior of the system as base 10 oscillates at different frequencies  $\omega$  compared to the natural frequency  $\omega_n$  of radiation-cancelling device 12. It can be seen that at low frequencies of the driving structure,  $|V_1/V_0|$  is approximately equal to 1, and the motion of the body 14 of device 12 is in phase with that of the base. Near the resonance frequency of device 12, the base and the device are still in phase, but the motion of the radiation-cancelling device is highly amplified. If the driving frequency provided by the structure is slightly above the natural frequency of device 12, however, the motion of the radiation-cancelling device not only is amplified but also is 180 degrees out of phase with that of the structure.

[0018] If base 10 and device body 14 radiate from only their top surfaces, then the total radiated sound pressure  $p$  at a point some distance away from the structure and attached body is thus combined pressure from the base and the body, and pressure  $p$  is proportional to  $V_0 A_0 + V_1 A_1$ . One can then see that if  $V_1$  is opposite in phase to  $V_0$ , then the volume velocity (product of velocity amplitude and area) radiated from device body 14 cancels part of the volume velocity radiated from the base structure, and  $p$  will be reduced as  $V_1 A_1$  is made larger. Therefore, if there is significant amplification of radiation-cancelling device 12, i.e., if  $V_1 \gg V_0$ , only a small body mass area ( $A_1$ ) is required to produce a total radiated pressure  $p$  near to zero.

[0019] This phenomenon is most effective when the oscillating radiation-cancelling device 12 is very lightly damped. Consider a damped system with loss factor  $\eta$ . If this system is driven slightly above its resonance frequency, then for motion of device 12 opposite in phase to that of the base and at a frequency  $\omega$  such that  $\omega^2 = \omega_n^2(1 + \epsilon)$ , then  $|V_1/V_0| = 1/(\eta^2 + \epsilon^2)^{1/2}$ . Note that  $|V_1/V_0|$  decreases as the loss factor  $\eta$  increases and as the vibration of the base deviates from the resonance frequency of radiation-cancelling device 12. Thus, the amplification is reduced by both material damping and the frequency offset. Also, the phase is degraded from 180 degrees by damping.

[0020] In practice, as distinct from the ideal case, there will also be radiation from the underside of the radiation-cancelling device body 14, which radiation should be minimized. FIG. 3 shows two options for minimizing this radiation: providing a baffle 18 or providing a flexible closure or bellows 20. With a baffle, however, there are problems with alignment and with friction, which can induce damping and reduce the effectiveness of the system. A bellows can induce noise radiation and create problems with keeping a constant system stiffness with changing temperature or external pressure.

[0021] The following example is intended to illustrate the advantages of the present invention and to assist one of ordinary skill in making and using the same. This example is not intended in any way otherwise to limit the scope of the disclosure.

[0022] Referring to FIG. 4, an experimental system according to the invention was constructed to demonstrate the principles of the invention. A schematic diagram of the system of FIG. 4 is given in FIG. 5. Referring to FIG. 5, the system according to the invention consists of a rigid piston 22 driven by shaker 24 to represent a vibrating structure to be quieted (equivalent to base 10 in FIG. 1). A radiating-cancelling device 26 bonded to piston 22 is in the form of an inverted metal cup. The piston system is sealed in a heavy wooden box 28, and silicone is used to fill the gap 30 between the piston and the wooden box. Metal cup 26 functions as a spring-mass system. In this configuration, the metal of the cup provides a finite but minimal amount of material damping, and the stiff sides of the cup ensure that there is minimal unwanted radiation from the underside of the cup bottom to interfere with the sound radiation from the outside face of the cup. The cup is also sealed to the piston to prevent additional damping due to air leakage from the underside of the cup.

[0023] Referring again to FIG. 4, in this test apparatus the piston has a diameter of 12 cm, and the radiation-cancelling device (or damper) is a copper cup 4 cm in diameter (for an area ratio of approximately 12%) and approximately 1 mm thick. An accelerometer is used to monitor the normal velocity of the piston and the sound pressure is measured with a microphone about 290 cm away. All tests were carried out in an anechoic chamber.

[0024] If the damper, or "canceller," is modeled as a base driven, simply-supported circular plate supported and driven at its edges, then the predicted performance of the experimental system on axis for the listed parameters is shown in FIG. 6, a graph of the predicted sound pressure level versus the driving frequency. When piston 22 is driven at the natural frequency of metal cup 26, the sound pressure will be amplified as the cup is vibrating with a much larger amplitude than that of the undamped piston. As the driving frequency increases, however, there is a phase shift and noise cancellation begins. At some frequency, estimated here to be about 1060 Hz, the total radiated sound pressure will be near zero. FIG. 7 shows the measured on axis performance of the system. As can be seen, with the use of a system according to the invention, at a driving frequency of about 1065 Hz, the on-axis radiated sound pressure from the vibrating piston was reduced by almost 22 decibels.

[0025] The system of the invention finds useful application to quiet, e.g., electric transformers, enclosure bodies of fixed-speed machines and train-wheel screech. A transformer is a prime candidate for application of the principles of the method of the invention because it always produces the same frequencies and because essentially no approaches except barriers and active systems have found to be useful so far.

[0026] To quiet a transformer, one would measure its noise to determine the exact frequencies at which it radiates sound. One would then carry out a survey of the transformer's surfaces in order to ascertain which surfaces are responsible for the dominant sound radiation, as well as the shapes of

these surfaces and the configurations in which they are vibrating. This information permits a determination of where radiation-cancelling devices, or "cancellers," should be attached and how large their radiating areas would need to be so that the product of the canceller's area and its velocity amplitude will be nearly equal to the product of the radiating area and the spatial average of its velocity amplitude. It is possible that small adjustments to a canceller's natural frequency will need to be made in situ, in order to optimize its performance. These adjustments can readily be made by adding or removing small amounts of mass to the body of the canceller.

[0027] These same inquiries would be made for other applications of the method of the invention, e.g., to quiet train wheel screech. For this application in particular, however, care would have to be taken to make the size and velocity amplitude of individual cancellers sufficiently small that the canceller would not become separated from the train wheel during operation of the train.

[0028] While the present invention has been described in conjunction with a preferred embodiment, one of ordinary skill, after reading the foregoing specification, will be able to effect various changes, substitutions of equivalents, and other alterations to the compositions and methods set forth herein. It is therefore intended that the protection granted by Letters Patent hereon be limited only by the definitions contained in the appended claims and equivalents thereof.

What is claimed is:

1. A system for cancelling noise radiation from a vibrating structure, said system comprising:

a vibrating structure, said vibrating structure having a sound radiating area; and

a radiation-cancelling device, said radiation-cancelling device having a sound radiating area, wherein said radiation-cancelling device comprises a spring-mass system cooperatively attached to said vibrating structure and wherein, further,

the motion of said vibrating structure provides the driving frequency for oscillation of said spring-mass system in said radiation-cancelling device; and

said radiation-cancelling device is designed so that the natural frequency of said spring-mass system in said radiation-cancelling device is lower than the vibration frequency of said vibrating structure.

2. The system of claim 1, wherein the sound radiating area of said radiation-cancelling device is smaller than the sound radiating area of said vibrating structure.

3. The system of claim 2, wherein the sound radiating area of said radiation-cancelling device is less than one twentieth the sound radiating area of said vibrating structure.

4. The system of claim 1, wherein the sound radiating area of said radiation-cancelling device is larger than the sound radiating area of said vibrating structure.

5. The system of claim 1, wherein said vibrating structure is a transformer.

6. The system of claim 1, wherein said vibrating structure is a train wheel.

7. The system of claim 1, wherein the spring-mass system of said radiation-cancelling device is in the form of an inverted metal cup.

8. A method for cancelling noise radiation from a vibrating structure, said method comprising the steps of:

providing a vibrating structure in need of quieting, said vibrating structure having a sound radiating area; and

cooperatively attaching to said vibrating structure a radiation-cancelling device, said radiation-cancelling device having a sound radiating area, wherein said radiation-cancelling device comprises a spring-mass system and wherein, further,

the motion of said vibrating structure provides the driving frequency for oscillation of said spring-mass system in said radiation-cancelling device; and

said radiation-cancelling device is designed so that the natural frequency of said spring-mass system in said radiation-cancelling device is lower than the vibration frequency of said vibrating structure,

wherein, when said vibrating structure vibrates at said vibration frequency, noise radiating from said sound radiating area of said vibrating structure is cancelled by noise radiating from said sound radiating area of said radiation-cancelling device.

9. The method of claim 8, wherein the sound radiating area of said radiation-cancelling device is smaller than the sound radiating area of said vibrating structure.

10. The method of claim 9, wherein the sound radiating area of said radiation-cancelling device is less than one twentieth the sound radiating area of said vibrating structure.

11. The method of claim 9, wherein the sound radiating area of said radiation-cancelling device is larger than the sound radiating area of said vibrating structure.

12. The method of claim 8, wherein said vibrating structure is a transformer.

13. The method of claim 8, wherein said vibrating structure is a train wheel.

14. The method of claim 8, wherein the spring-mass system of said radiation-cancelling device is in the form of an inverted metal cup.

\* \* \* \* \*