

March 13, 1956

M. D. SIGLER

2,738,113

GOLF CLUB CARRIER AND LOCK

Filed Oct. 8, 1953

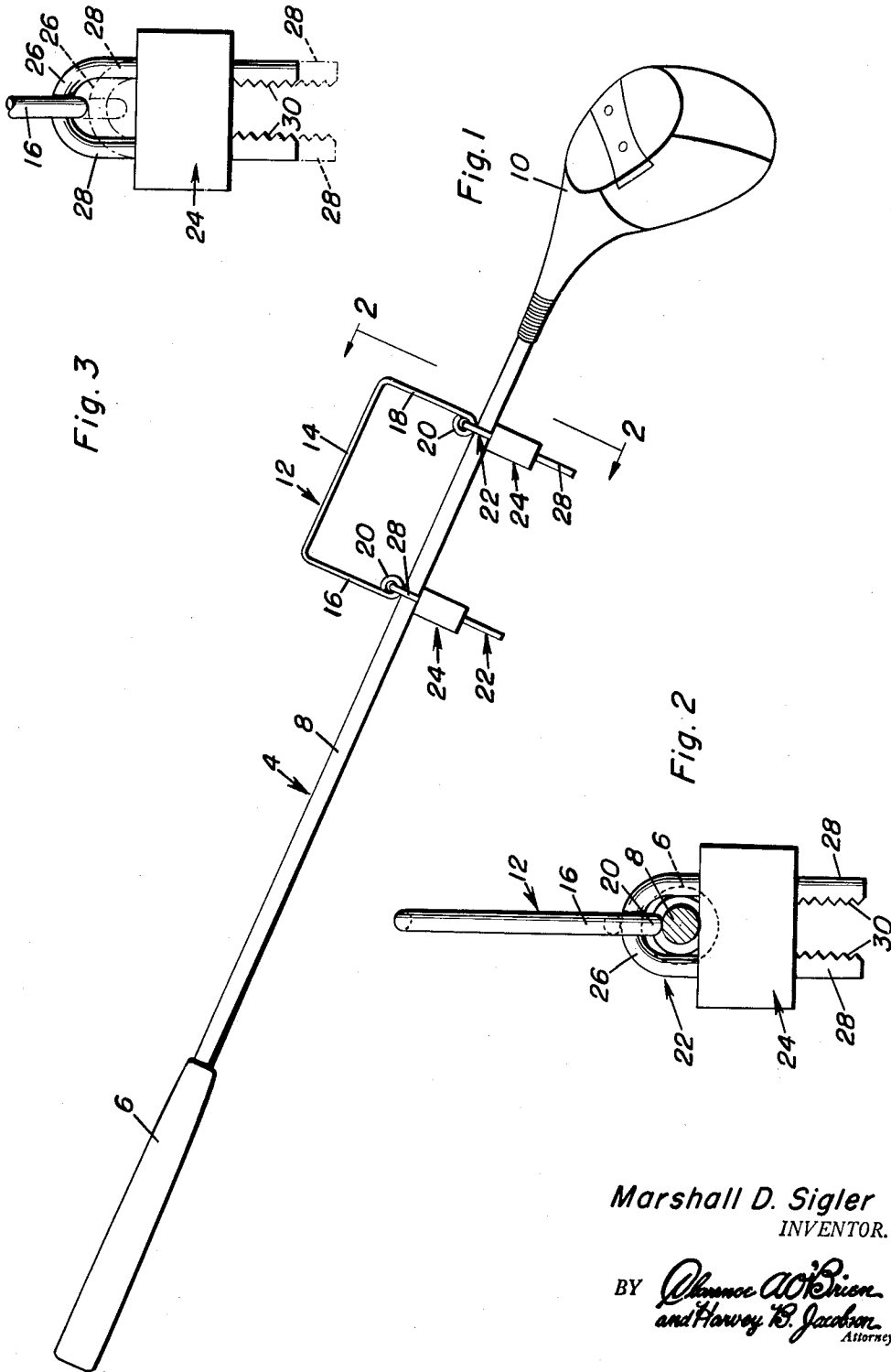

Marshall D. Sigler  
INVENTOR.

BY *Almon W. Orin*  
and *Harvey B. Jacobson*  
Attorneys

1

2,738,113

## GOLF CLUB CARRIER AND LOCK

Marshall D. Sigler, Richmond, Va.

Application October 8, 1953, Serial No. 385,008

1 Claim. (Cl. 224-45)

The present invention relates to a novel handle-equipped article carrier which is expressly, but not necessarily, adapted for connection with and the carrying of one or more golf clubs.

It is matter of common knowledge that some golfers follow the practice of carrying one or more golf clubs in one hand while walking along the fairway from the tee toward the green. In these circumstances there exists a need, it is believed, for a simple, practical, and readily applicable and removable golf club carrier of the type herein disclosed.

In carrying out a feasible embodiment of the over-all concept, a carrier is provided which is characterized by a handle and means whereby said handle may be readily and reliably connected with the shaft portion of one or more golf clubs to thus handily and aptly solve the problem at hand.

Taking into account another need of the golfer, it is a further objective to provide a carrier which is characterized by a pair of complementary padlocks and a bail-type handle wherein the ends of the arm portions of the bail are hingedly connected with the bight portions of the U-shaped shackles of padlocks to thus provide what is not only a satisfactory carrier which prevents removal singly of the golf clubs when desired but constitutes a good security measure when the clubs are checked through as luggage while travelling or when left or checked in hotels, clubhouses and so on.

Objects and advantages in addition to those specifically enumerated above will become more readily apparent from a studied consideration of the following specification, accompanying drawings and claim.

In the drawings, wherein like numerals are employed to designate like parts throughout the same:

Figure 1 is a side elevational view of a single golf club showing the improved carrier, constructed in accordance with the invention, and the manner in which the same is attached to the shaft of the club for conveniently carrying the latter;

Figure 2 is a section on the vertical line 2-2 of Figure 1 looking in the direction of the arrows; and

Figure 3 is a similar view showing, in full and dotted lines, the manner in which opening and closing of the parts of one padlock paves the way for either clamping or releasing the shaft portions of one or more clubs.

Referring now to the drawings and particularly to Figure 1, the numeral 4 designates a conventional golf club having a handle or hand-grip 6 and a shaft 8 with the usual head 10. It is usually desirable to grip the club, when carrying it about, somewhere near the head for

2

handy balance. So, and with this in mind, it is desirable likewise to attach the carrying device at the point where the hand would ordinarily be placed for carrying. Broadly, the device comprises a bail with means for attaching the ends of the arms of the bail to the shaft. Specifically, the bail is a U-shaped wire or equivalent member and is here denoted by the numeral 12 and embodies a bight portion 14 and a pair of lateral arms 16 and 18. These arms terminate in eyes or the like 20-20 which are connected with the first and second padlocks in the manner shown. Each padlock is the same in construction and therefore each one comprises a suitably sized U-shaped shackle 22 and a readily attachable and detachable key-controlled body portion for locking the casing 24 carried thereby. More specifically, the shackle has a bight portion 26 with which the adjacent eye 20 is connected and includes spaced parallel limbs or arms 28-28 with rack teeth 30 adjustably connected with the latching mechanism (not shown) in the casing of the body part or section 24. With this arrangement the padlock may be either opened up or closed or otherwise adjusted as shown in full and dotted lines in Figure 3. This means that the space between the bight portion 26 and adjacent or cooperating edge portion of the casing provides accommodation means for the shaft of the club, making it possible to carry either a single club or, when bunched together, several clubs in an obvious manner.

From the foregoing, the construction and operation of the device will be readily understood and further explanation is believed to be unnecessary. However, since numerous modifications and changes will readily occur to those skilled in the art, it is not desired to limit the invention to the exact construction shown and described, and accordingly, all suitable modifications and equivalents may be resorted to, falling within the scope of the appended claim.

What is claimed as new is as follows:

A golf club carrier comprising a first padlock having a U-shaped shackle embodying limbs connected by a companion bight portion and a body portion detachably and adjustably mounted on said limbs, a second duplicate padlock having a corresponding U-shaped shackle with limbs connected by a bight portion and a body portion detachably and adjustably mounted on said limbs, and a U-shaped bail having spaced parallel coplanar arms and a bight portion connecting said arms together, said arms having free end portions terminating in eyes, said eyes being hingedly attached to the respective bight portions of the respective shackles whereby to thus provide a conveniently usable carrying handle which is swingably attached to the shaft of the golf club by way of the stated padlocks.

### References Cited in the file of this patent

#### UNITED STATES PATENTS

1,499,960	Almedia	July 1, 1924
1,652,233	Branick	Dec. 13, 1927
2,471,291	Soref et al.	May 24, 1949
2,486,827	Duncan	Nov. 1, 1949
2,508,302	Stue	May 16, 1950
2,655,300	Williams	Oct. 13, 1953

#### FOREIGN PATENTS

978,201	France	Apr. 11, 1951
---------	--------	---------------