



US 20050200949A1

(19) **United States**

(12) **Patent Application Publication**
Shirai et al.

(10) **Pub. No.: US 2005/0200949 A1**

(43) **Pub. Date: Sep. 15, 2005**

(54) **SURVEYING INSTRUMENT**

(30) **Foreign Application Priority Data**

(75) Inventors: **Masami Shirai, Saitama (JP);**
Shunichiro Wakamiya, Saitama (JP);
Homu Takayama, Saitama (JP); Kenji
Kaneko, Saitama (JP)

Oct. 19, 2000 (JP) 2000-319117 (P)

Publication Classification

(51) **Int. Cl.⁷** **G02B 23/00**
(52) **U.S. Cl.** **359/399**

Correspondence Address:
GREENBLUM & BERNSTEIN, P.L.C.
1950 ROLAND CLARKE PLACE
RESTON, VA 20191 (US)

(57) **ABSTRACT**

(73) Assignee: **PENTAX Corporation, Tokyo (JP)**

(21) Appl. No.: **11/124,282**

(22) Filed: **May 9, 2005**

Related U.S. Application Data

(62) Division of application No. 09/978,542, filed on Oct. 18, 2001.

A surveying instrument includes a sighting telescope having an objective lens and an eyepiece; an erecting optical system functioning so that an image formed by said objective lens is viewed as an erect image through the eyepiece; and a light shield device, positioned in an optical path extending from an incident surface of the erecting optical system to an exit surface of the erecting optical system, for preventing an off-field light bundle which is incident on the erecting optical system from reaching the eyepiece.

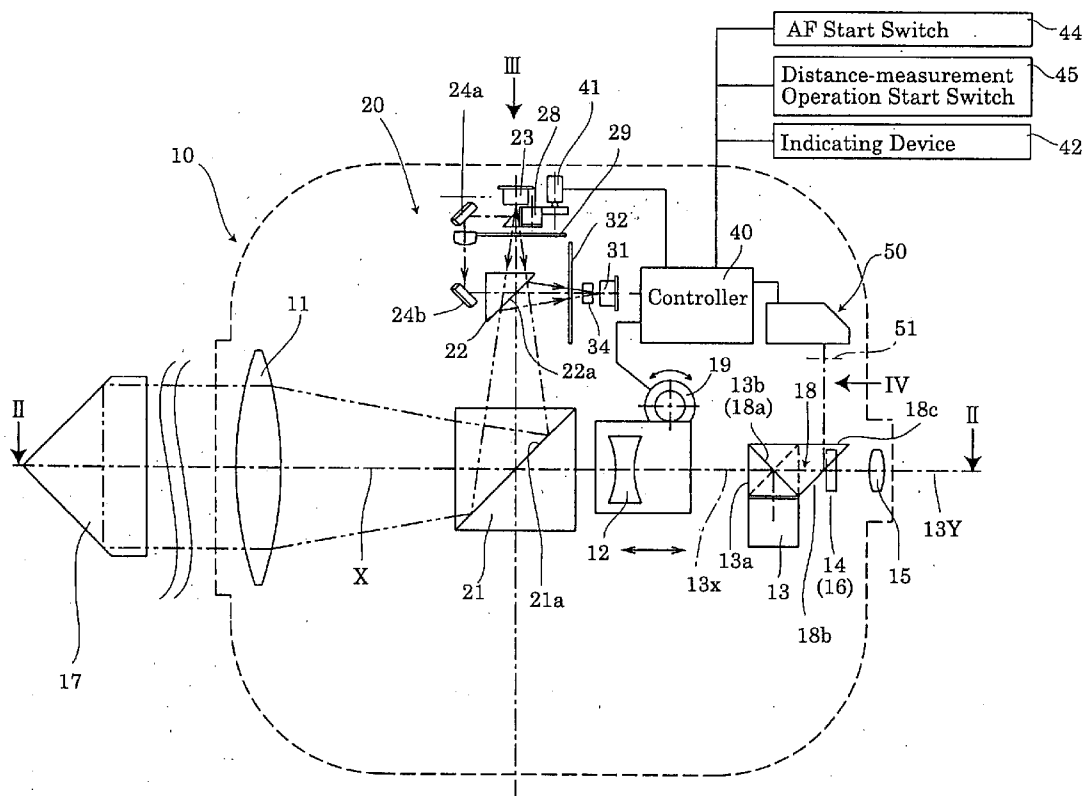

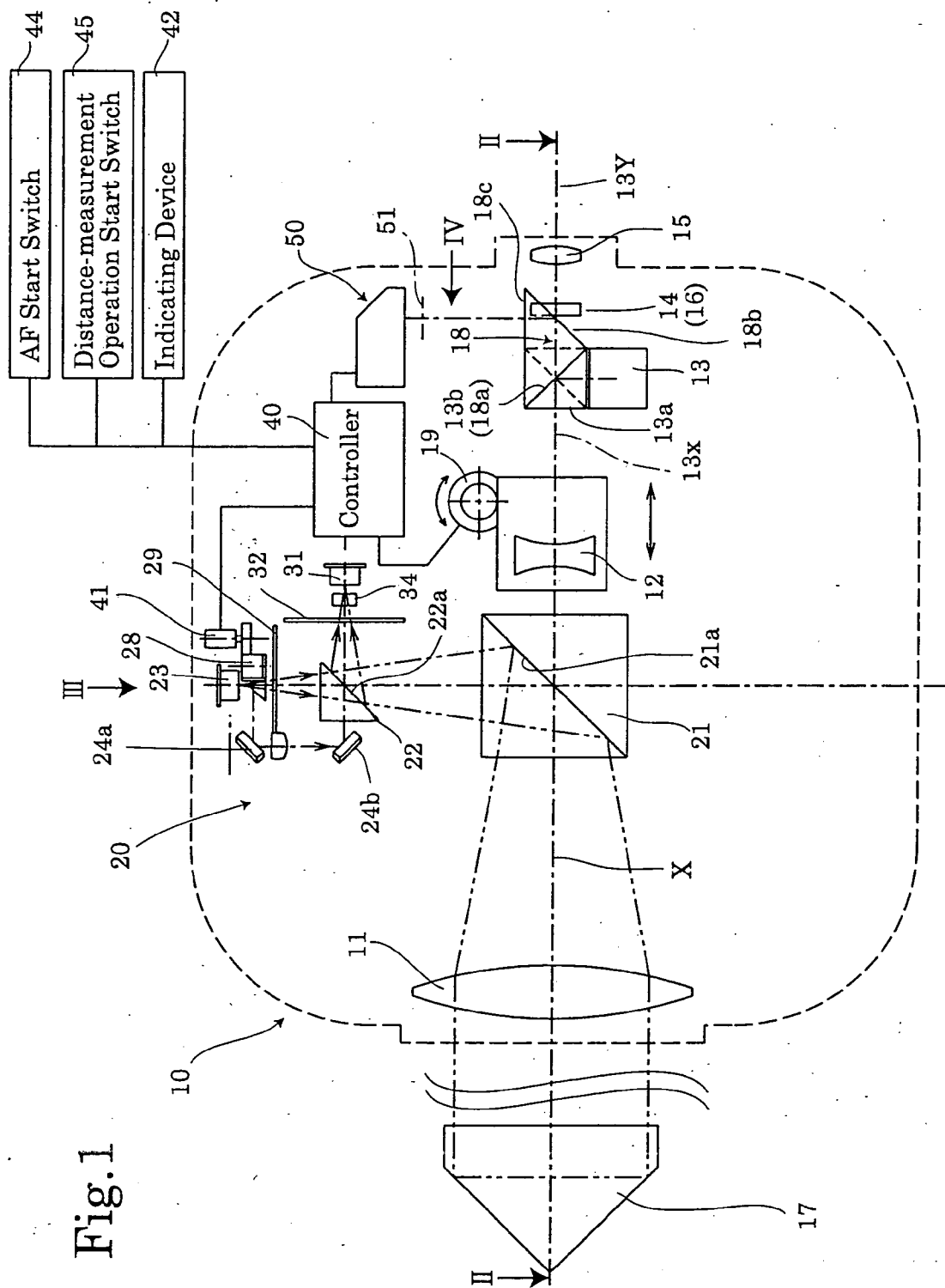

Fig. 1

Fig. 2

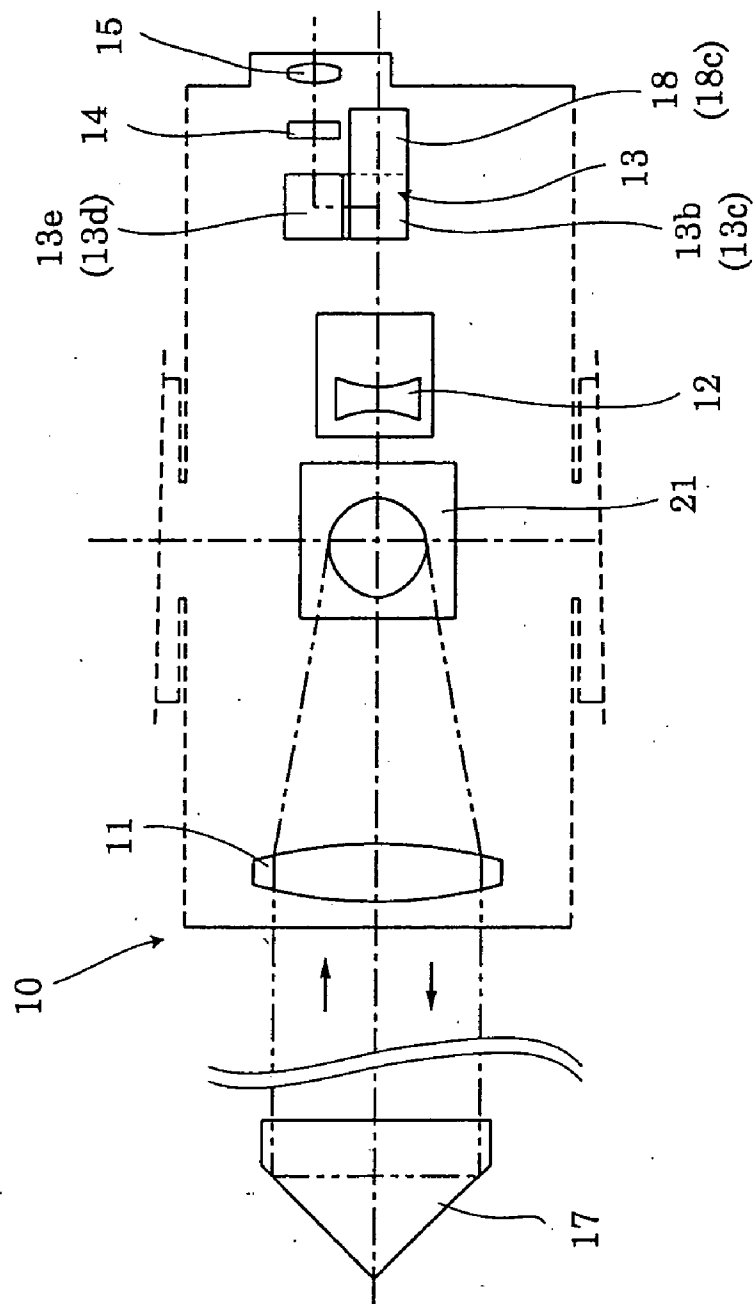

Fig.3

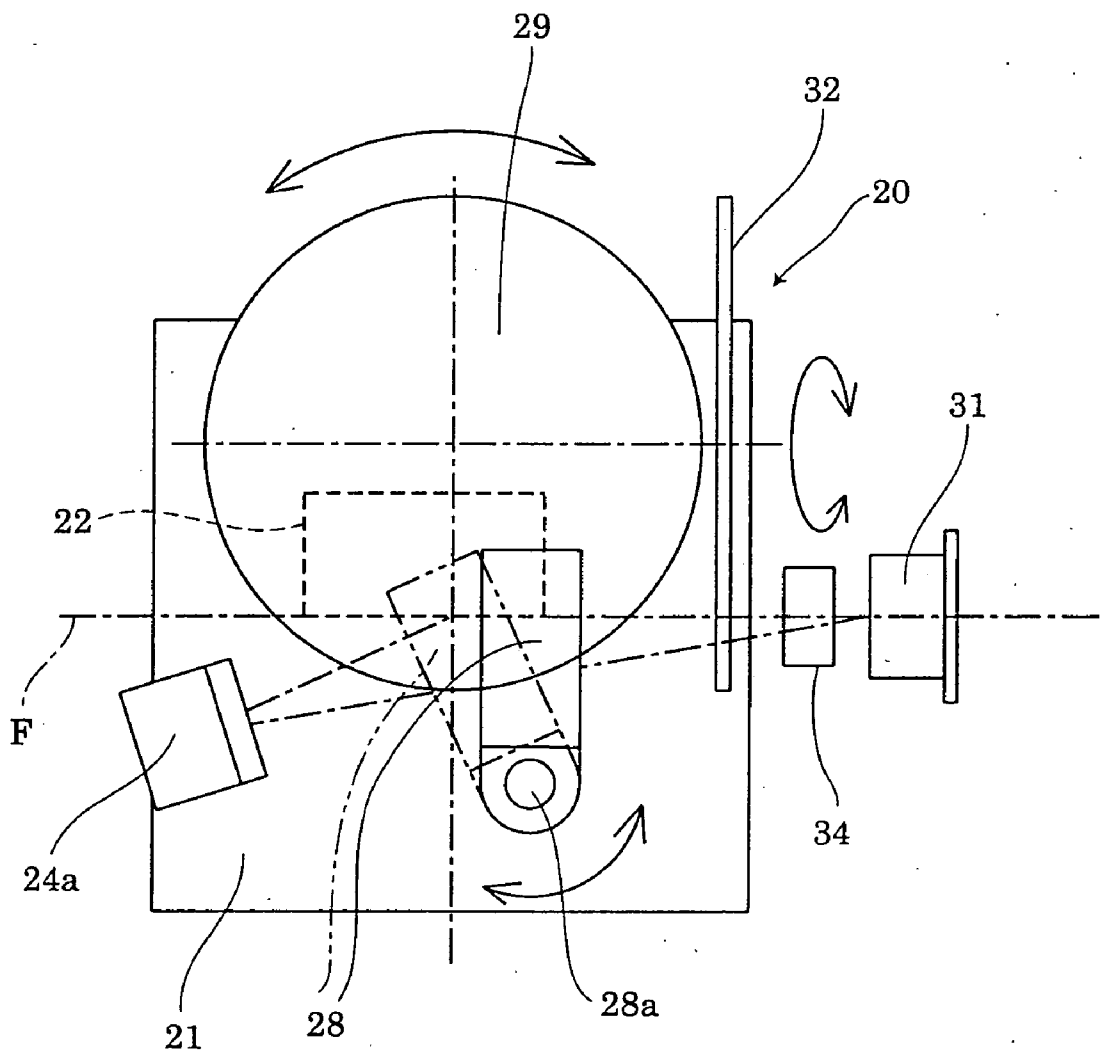

Fig.4

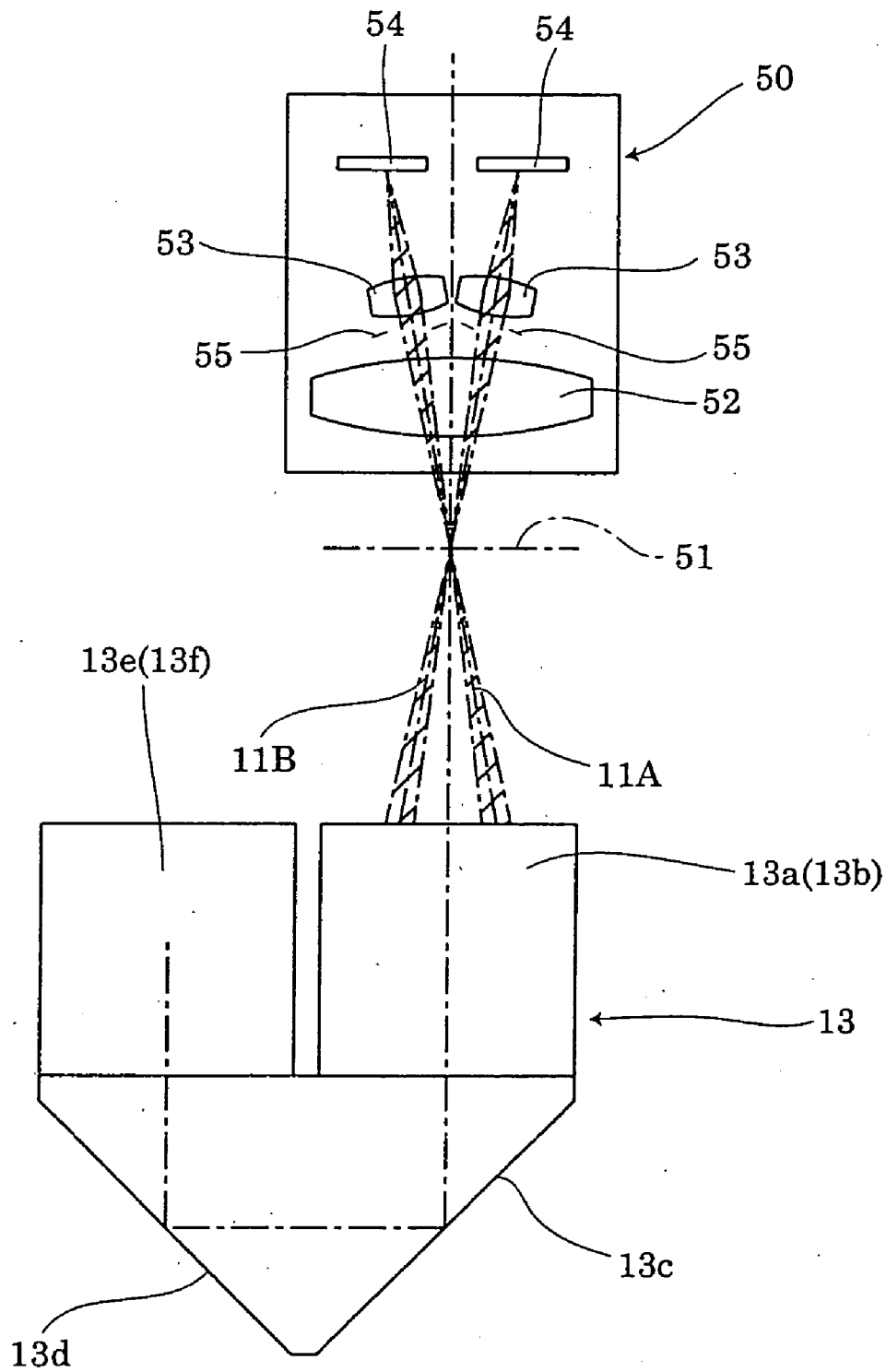

Fig.5

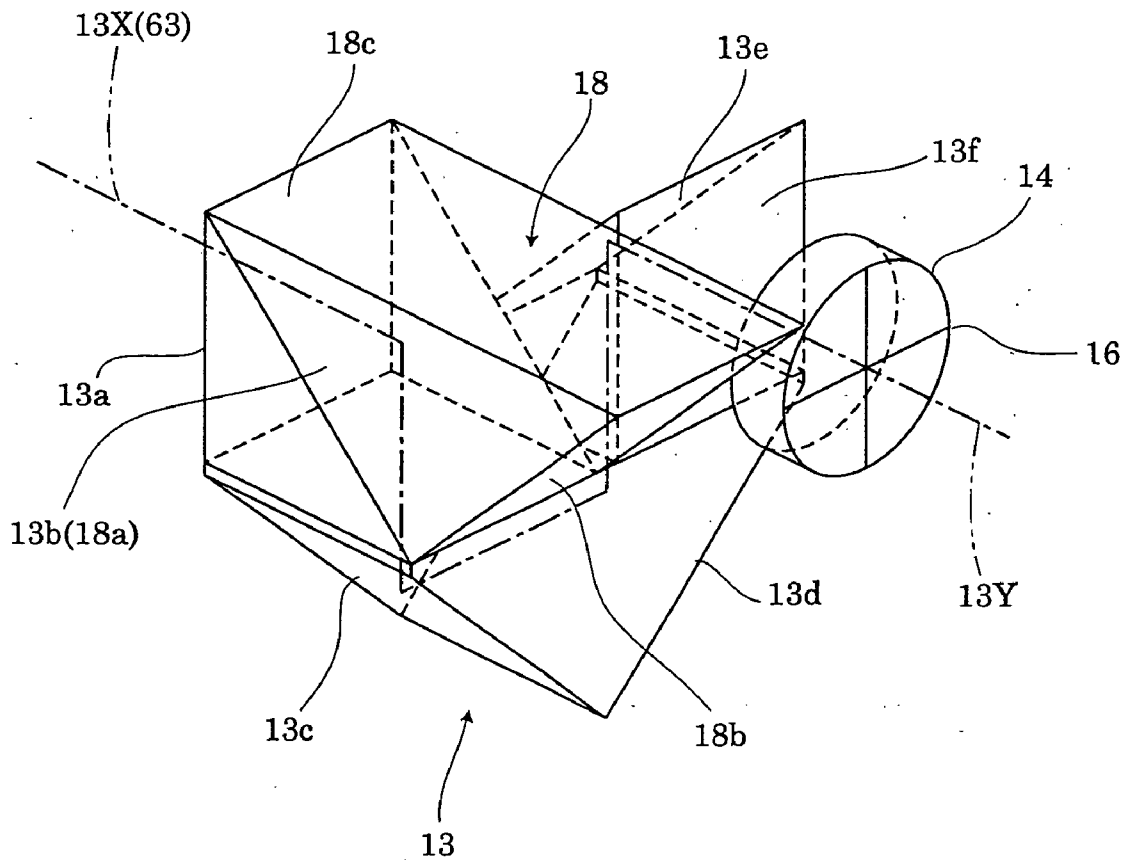

Fig 6

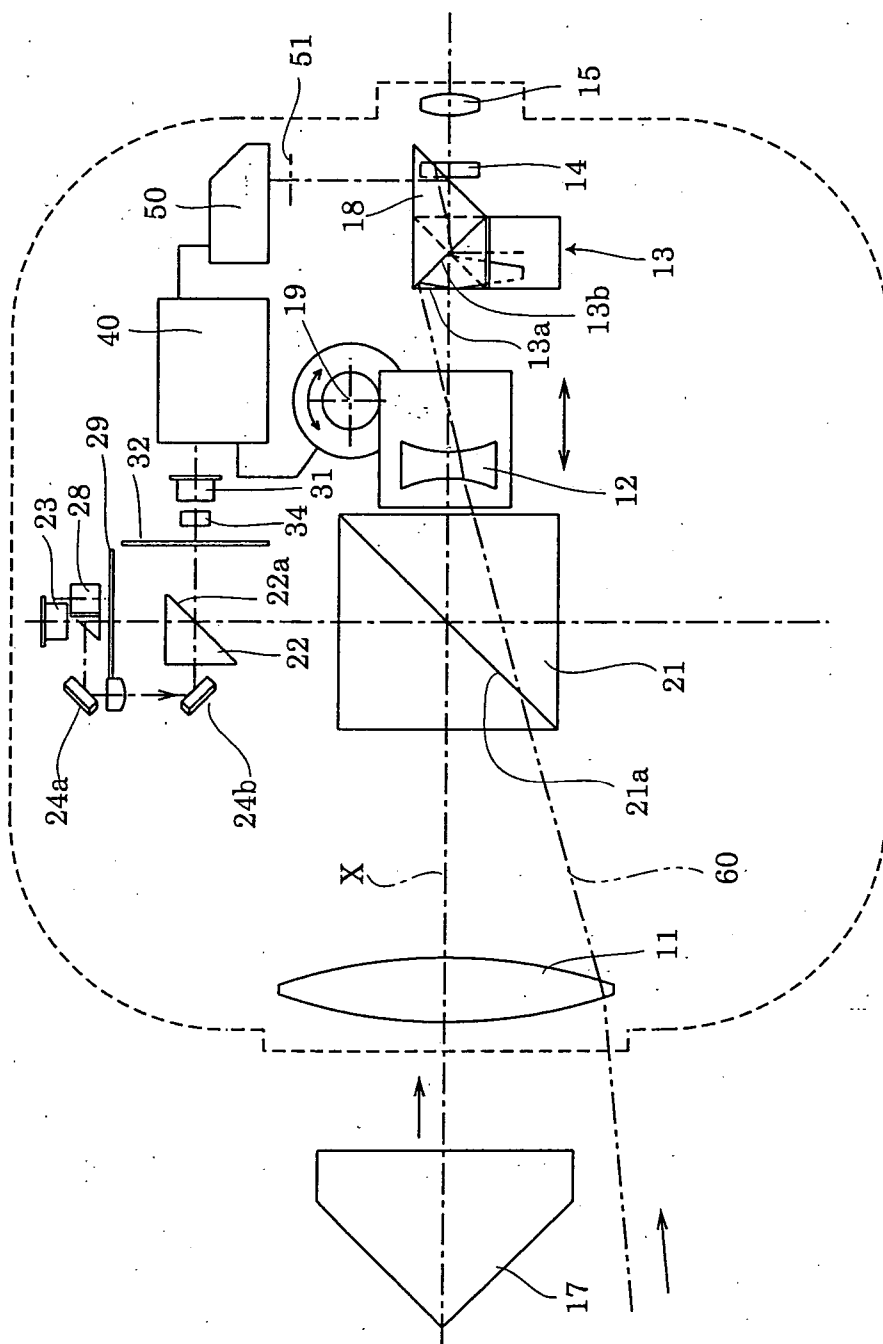
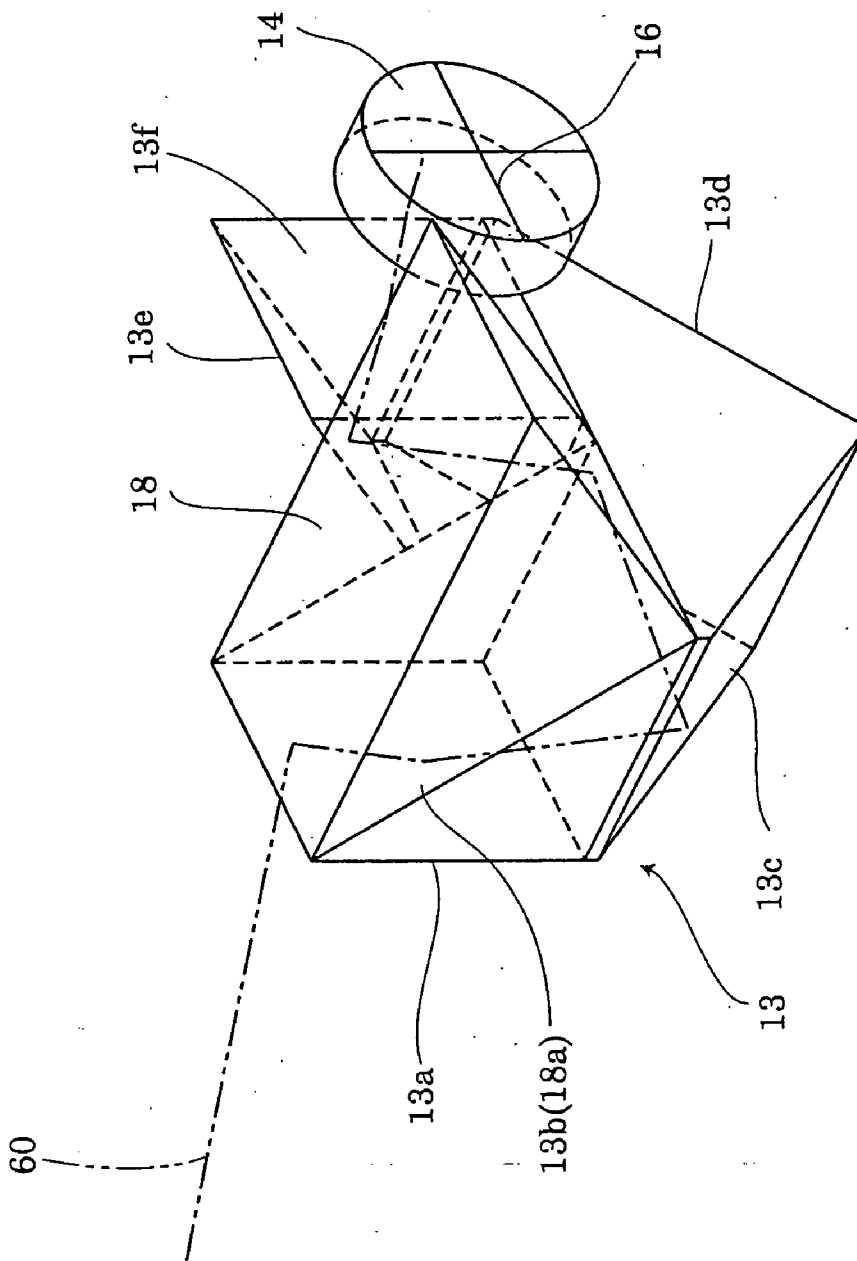

Fig. 7



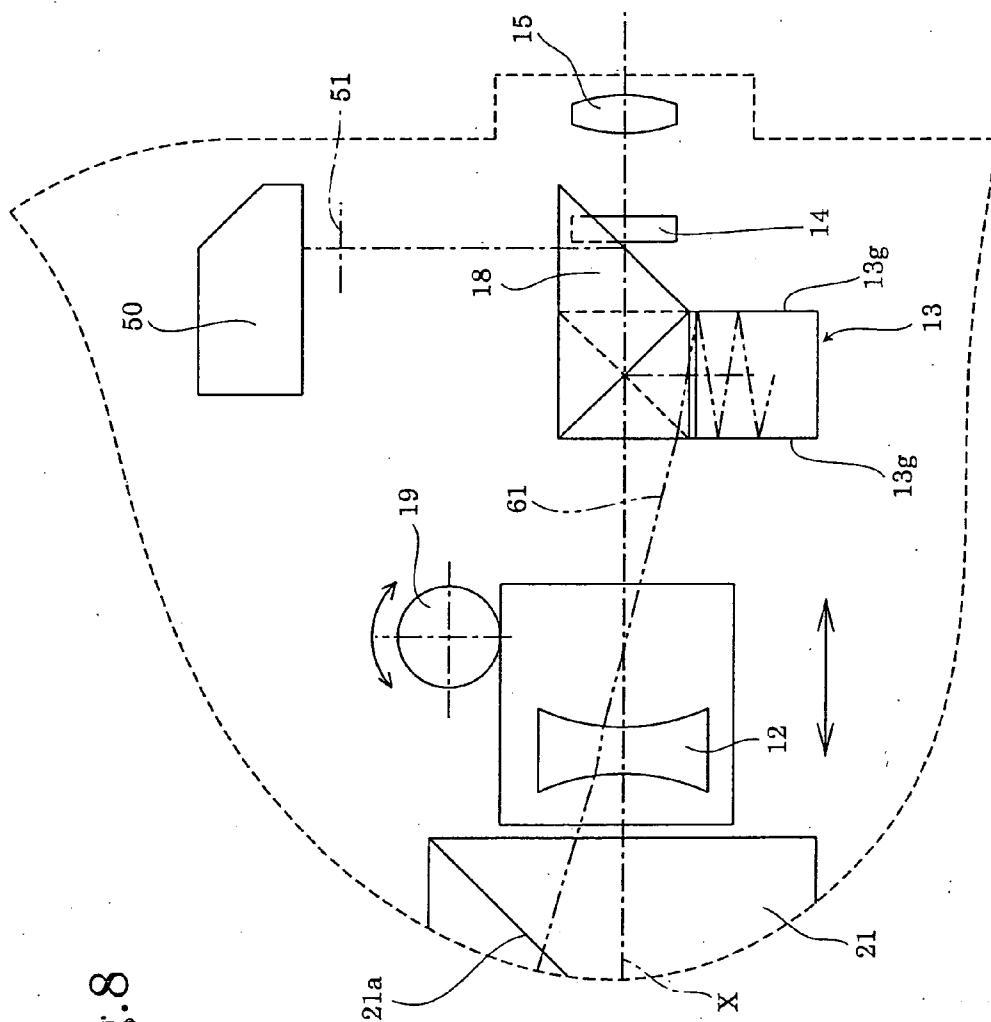

Fig. 8

Fig.9

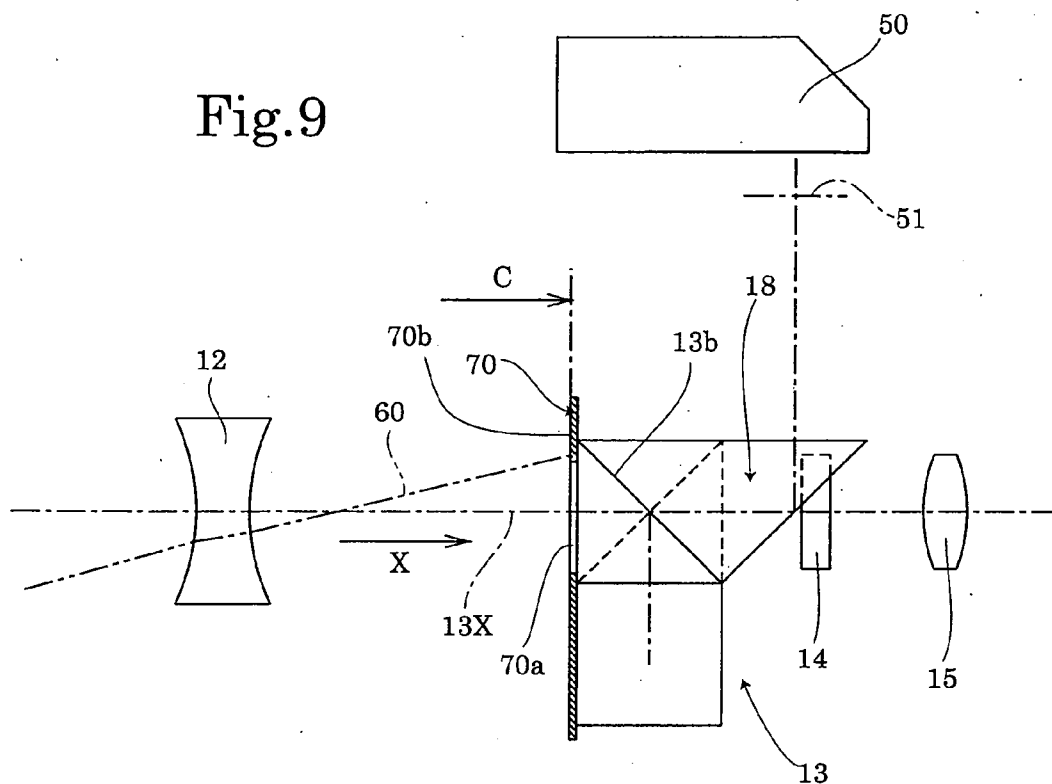

Fig.10

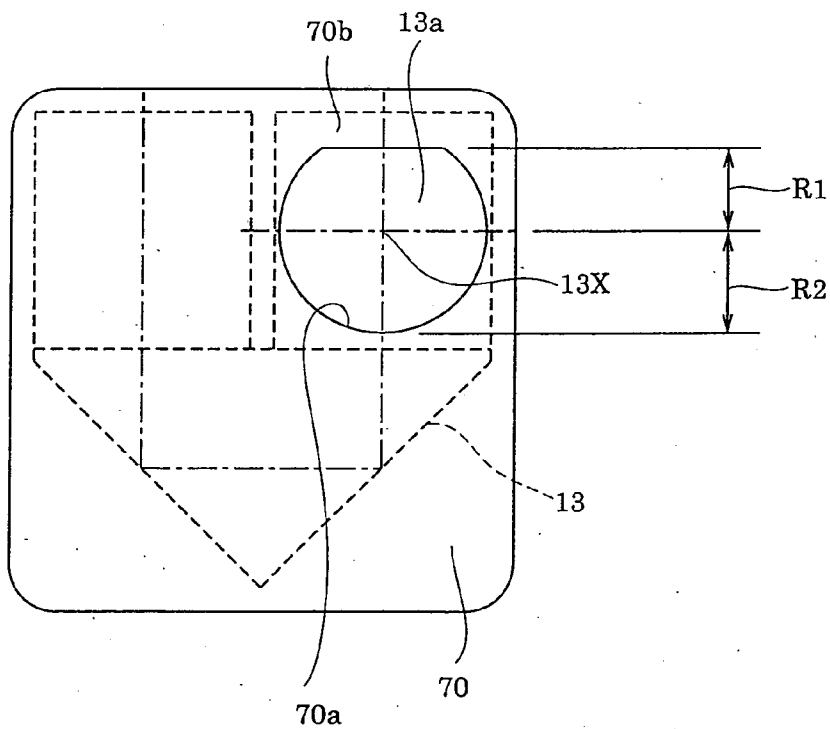

Fig.11

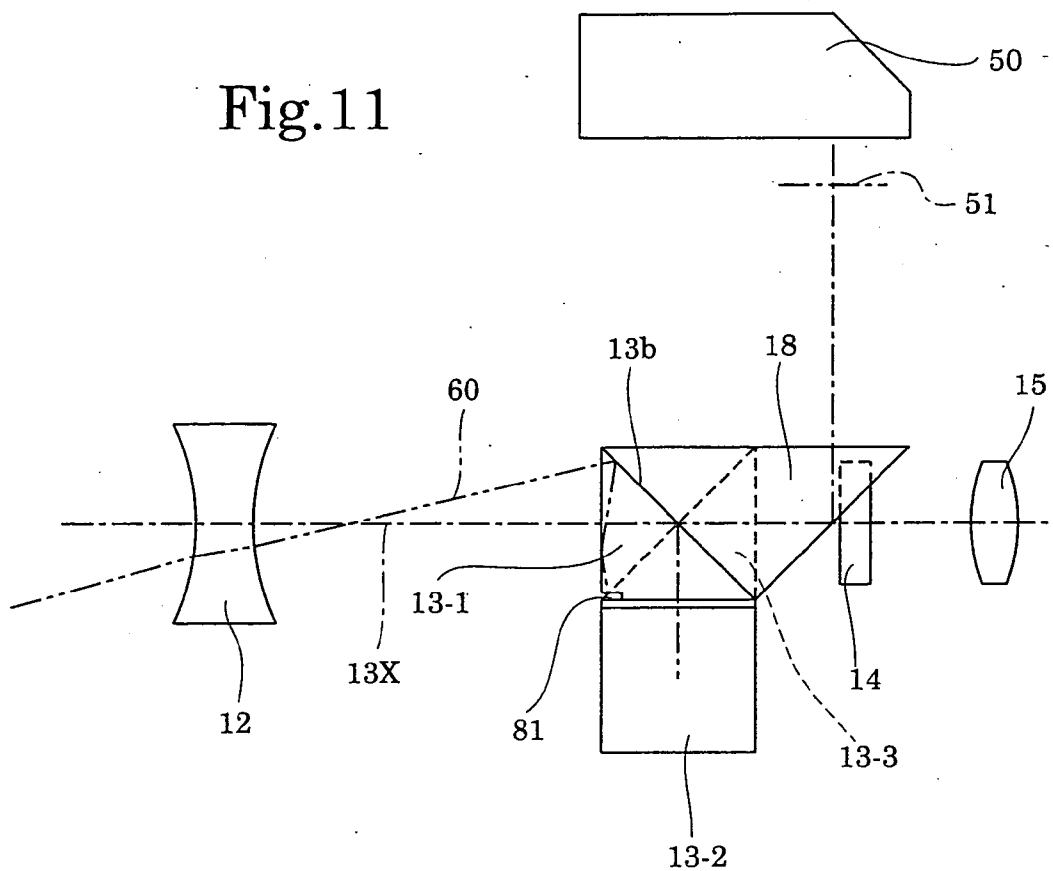

Fig.12

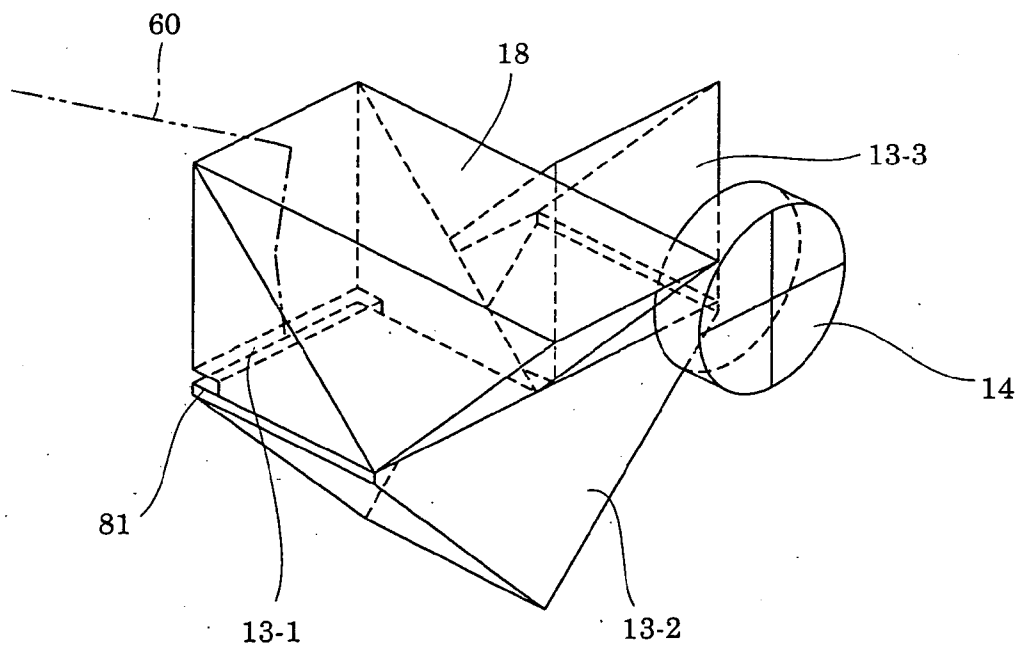

Fig.13

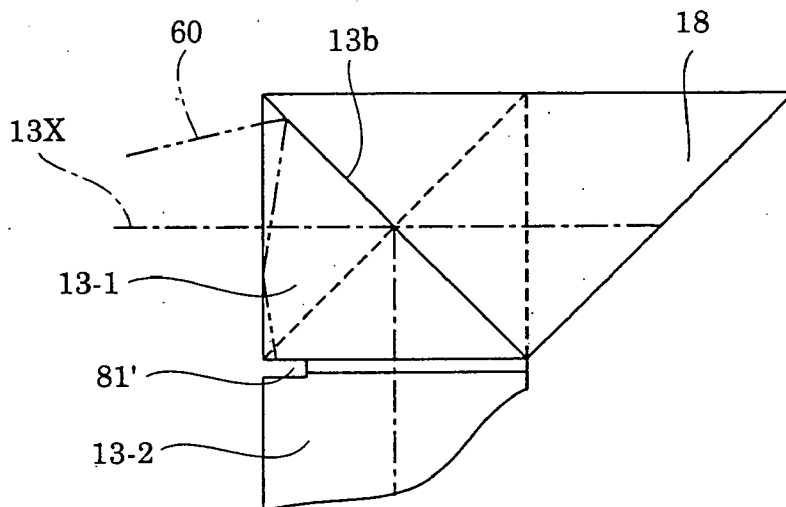

Fig.14

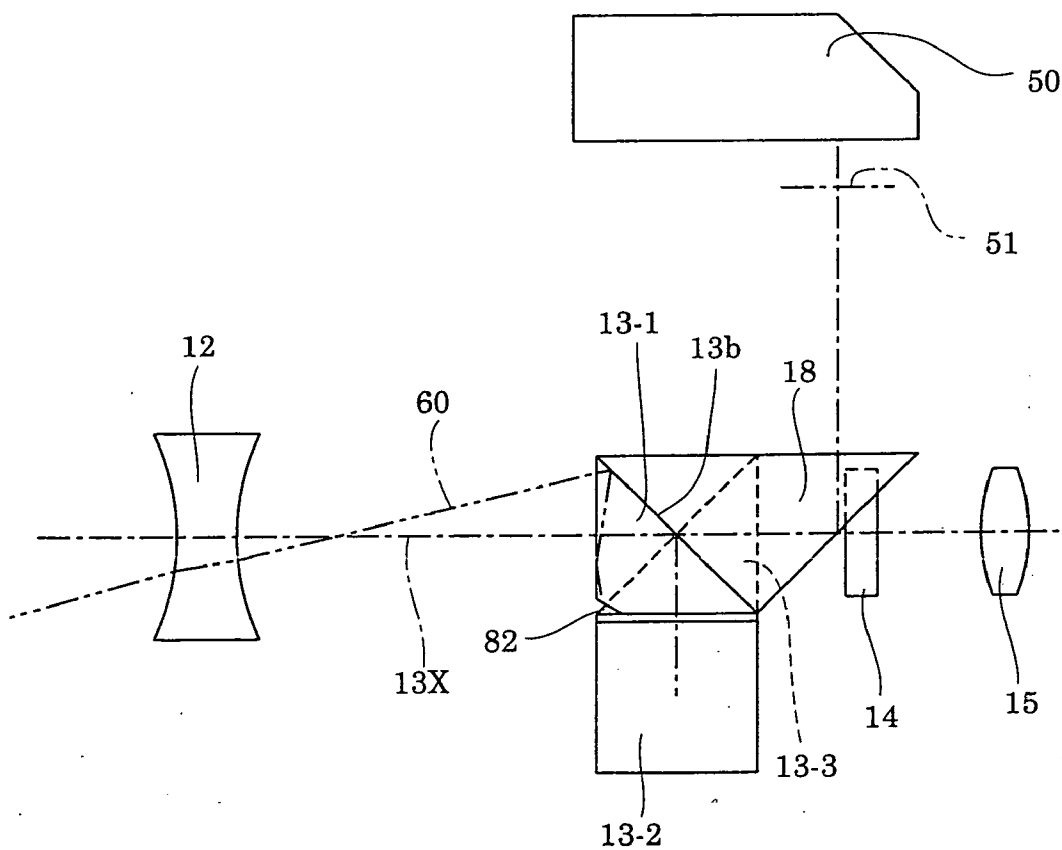

Fig.15

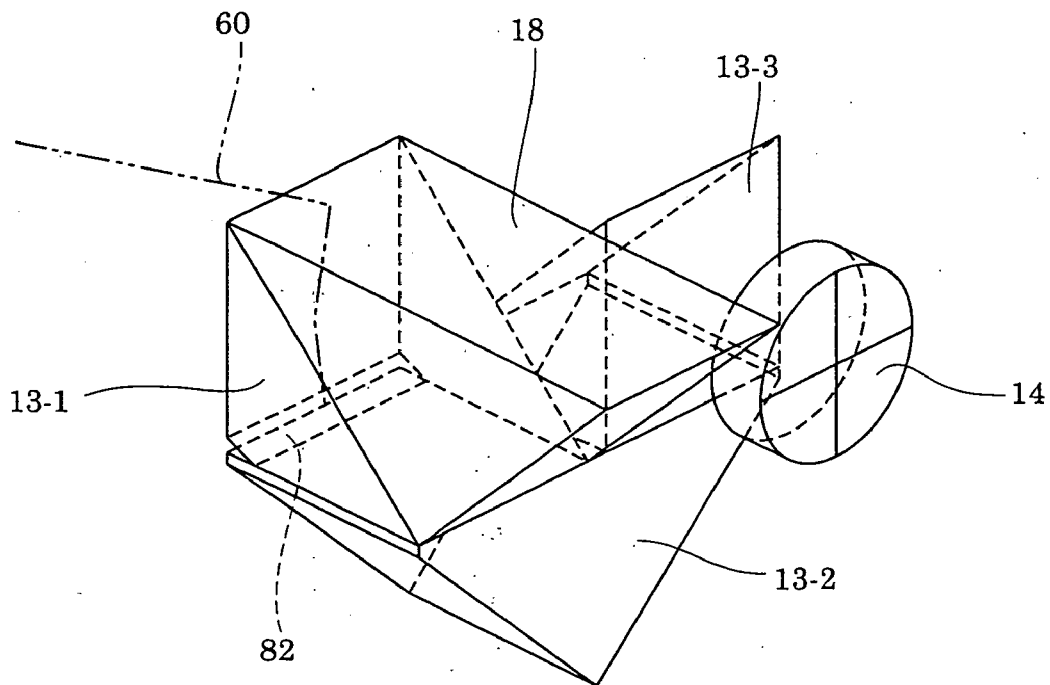

Fig.16

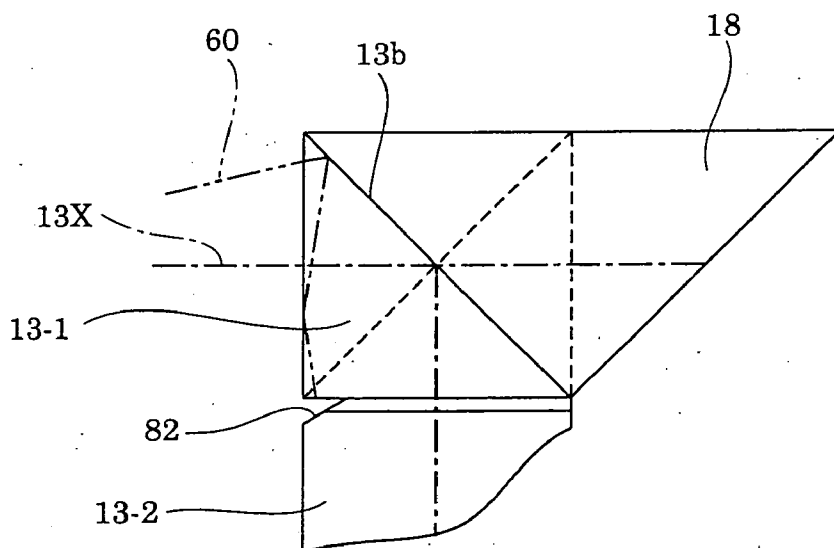

Fig.17

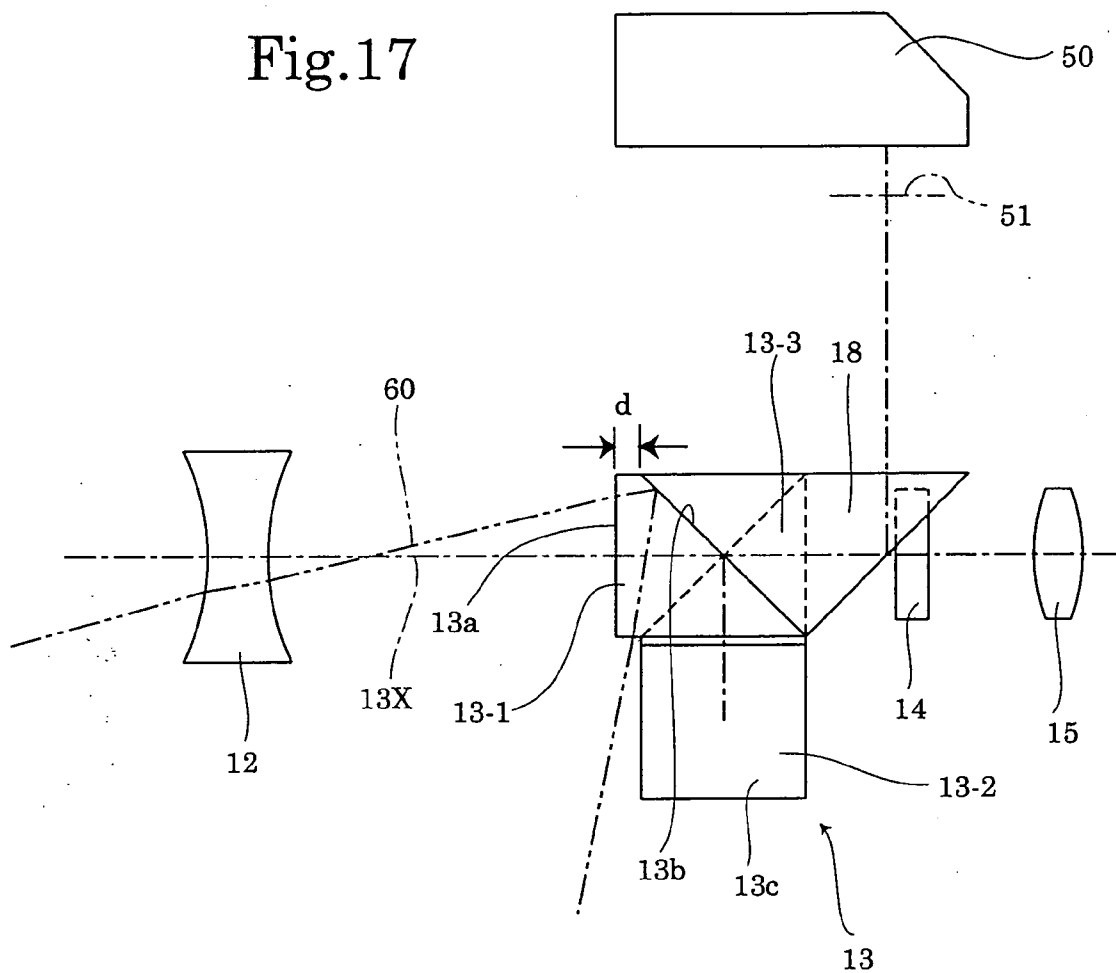

Fig.18

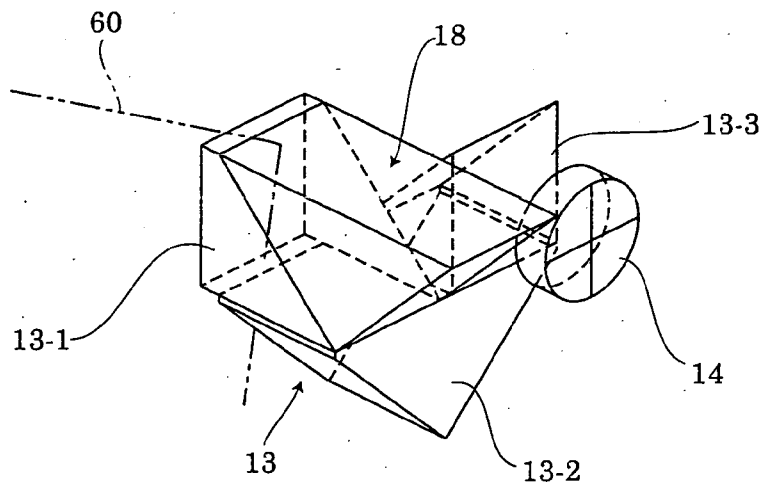

Fig.19

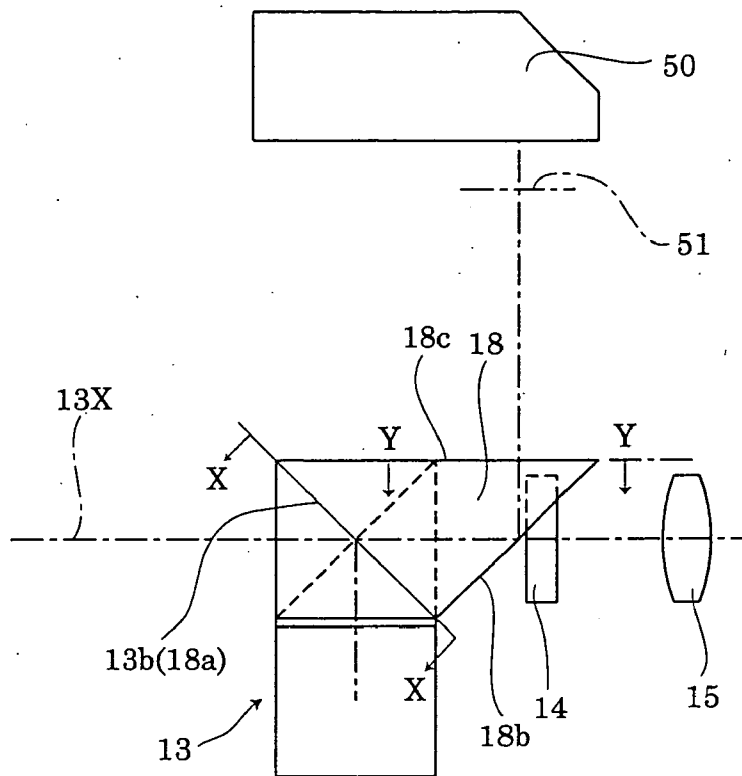

Fig.20

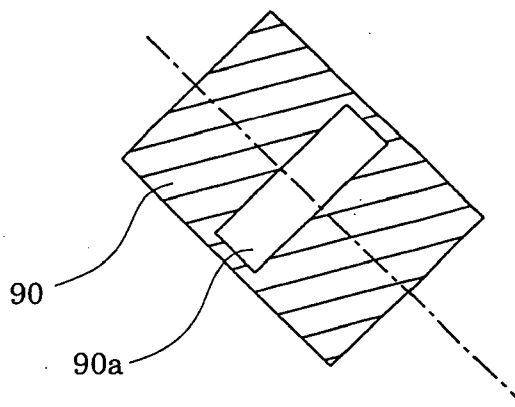

Fig.21

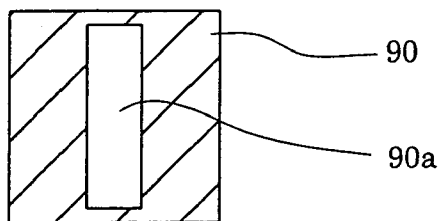

Fig.22

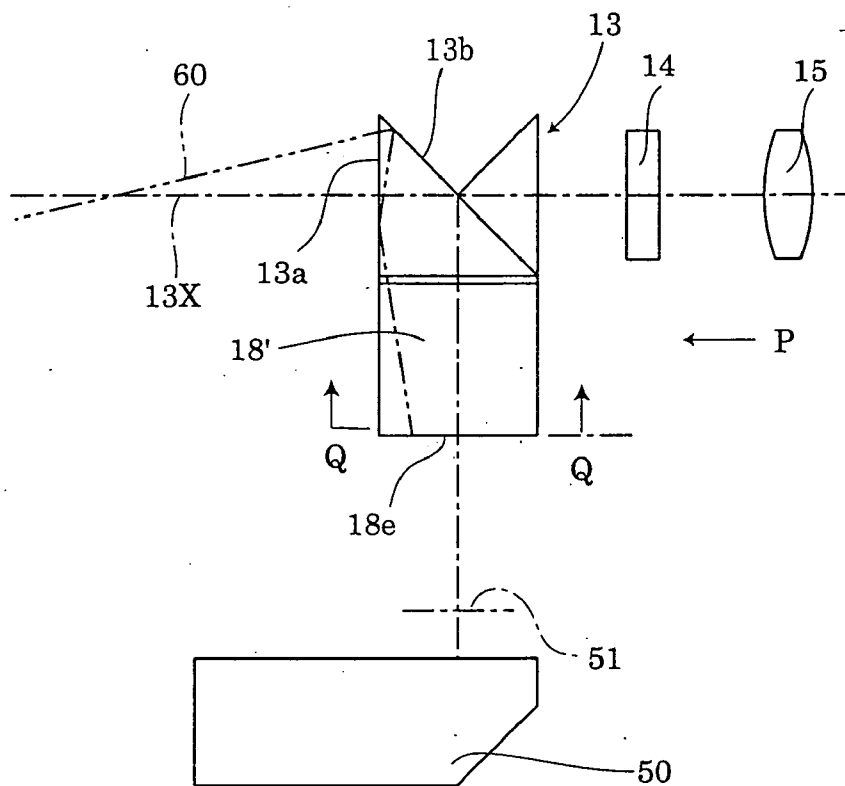

Fig.23

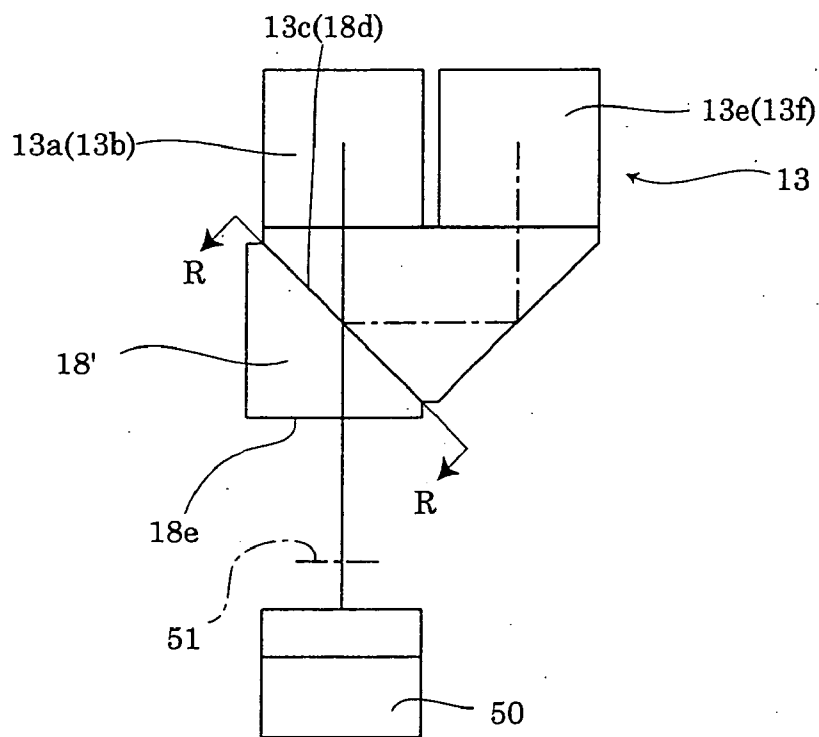

Fig.24

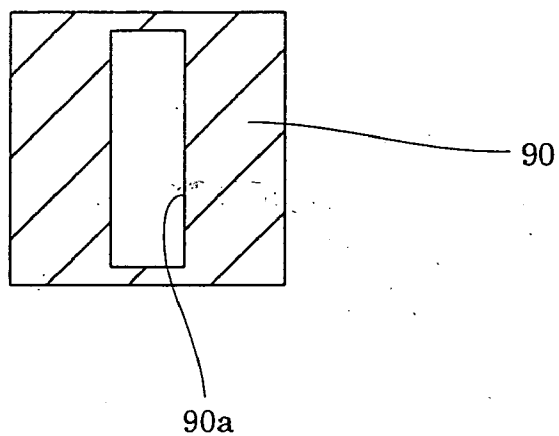

Fig.25

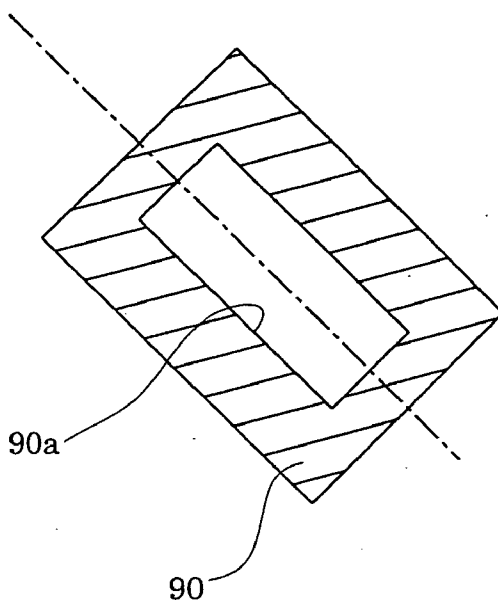

Fig.28

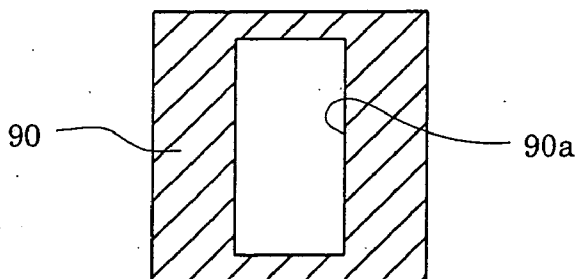

Fig.26

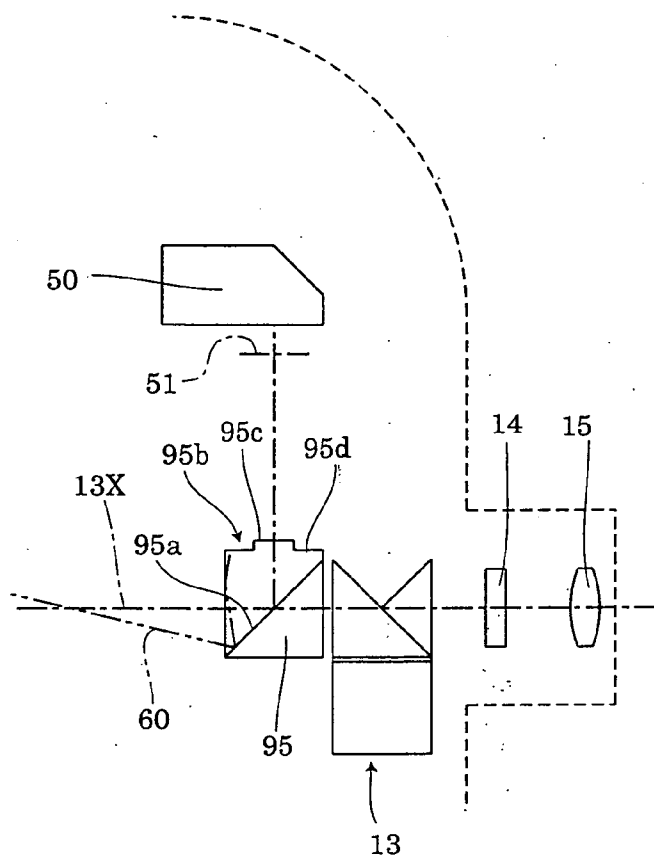
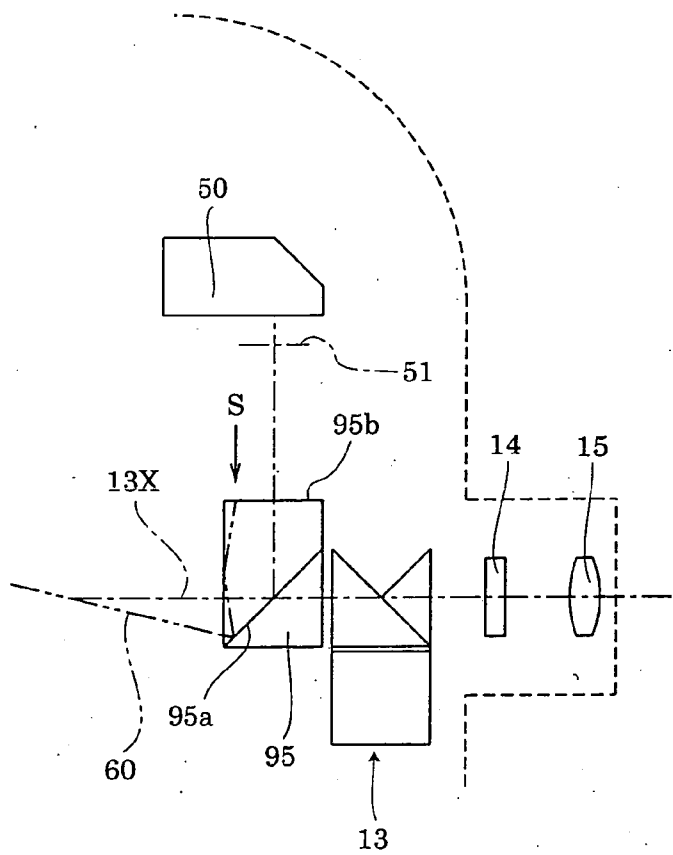

Fig.27



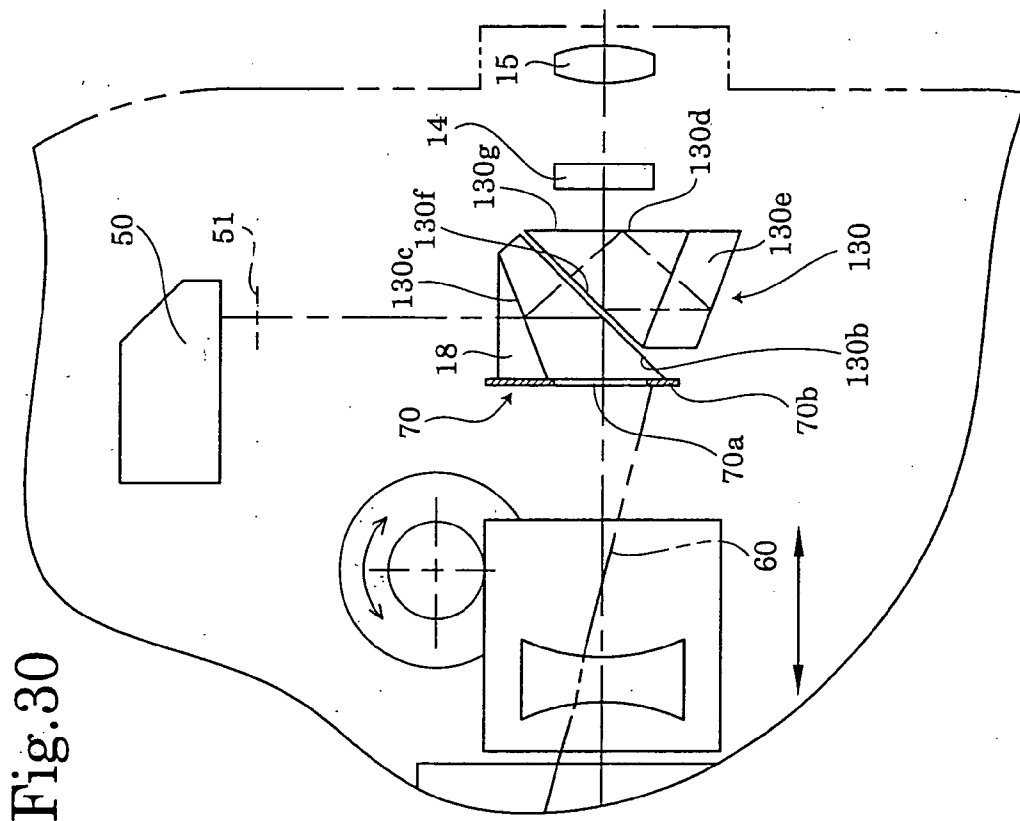

Fig.30

Fig.29

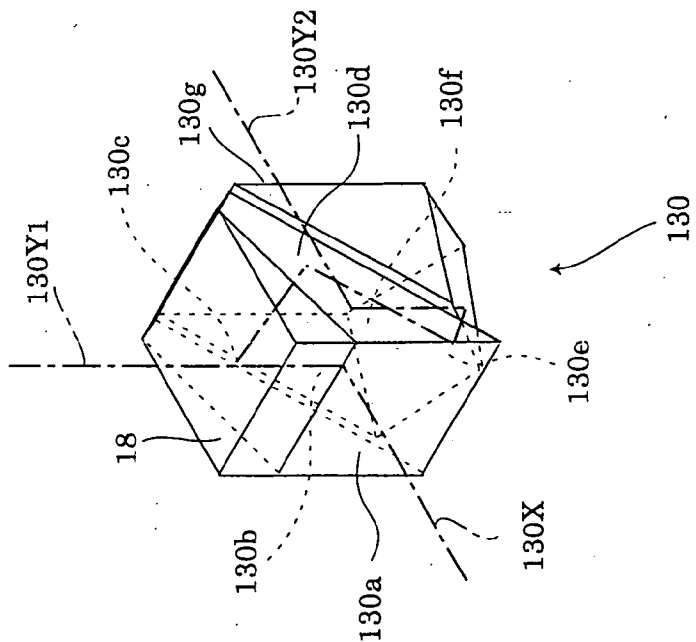

Fig.32

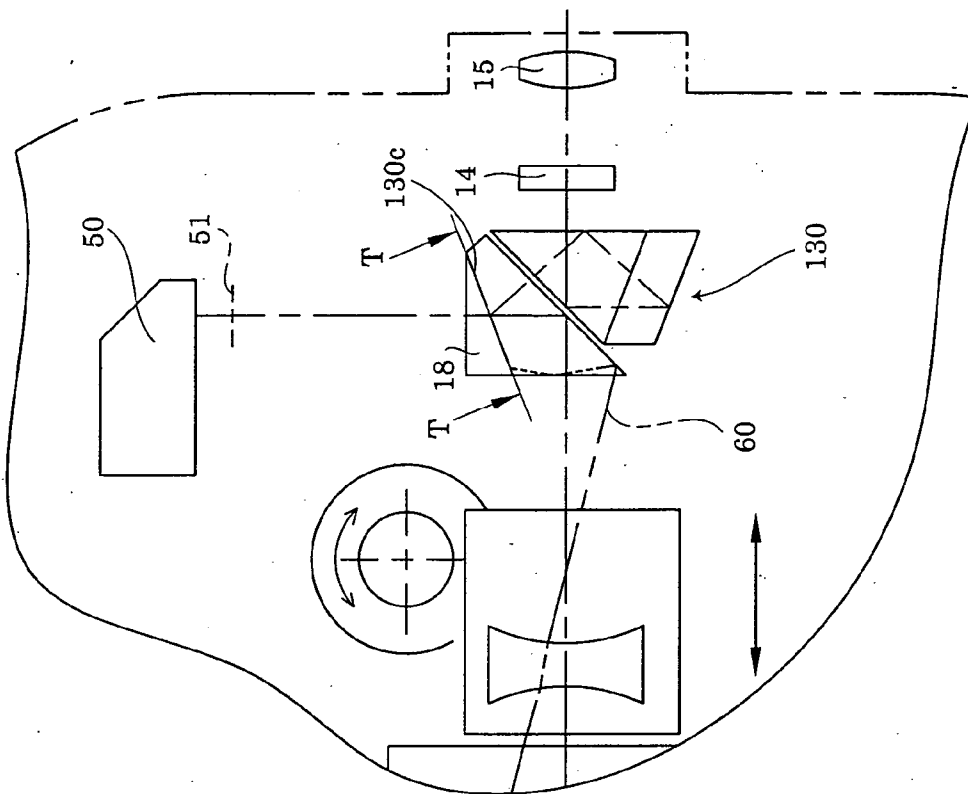

Fig.31

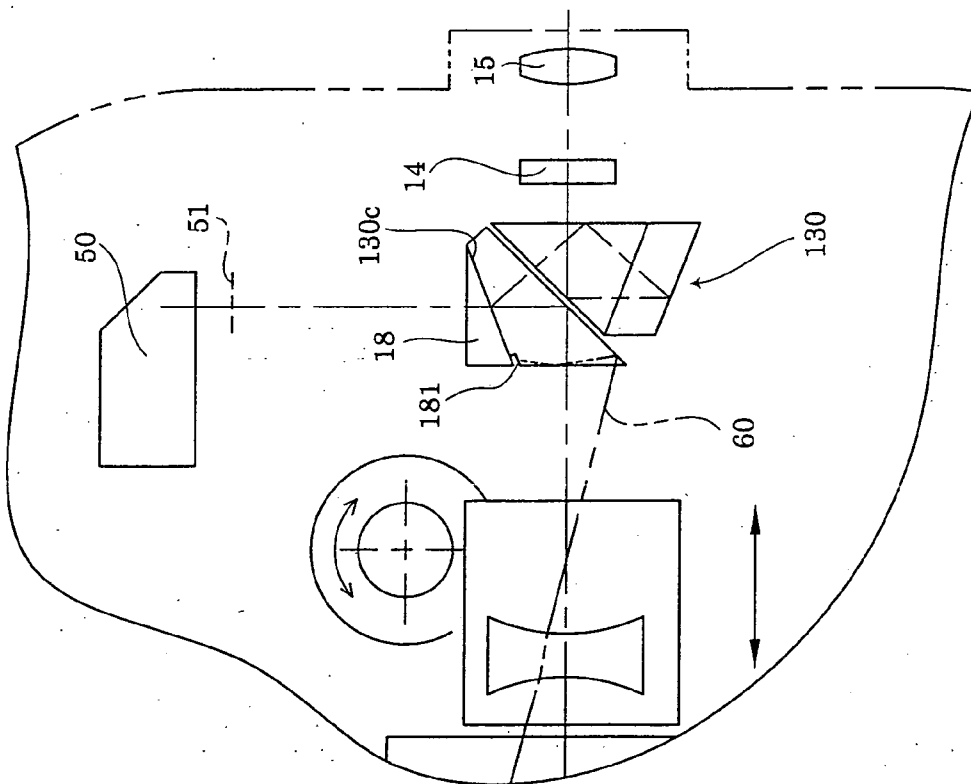
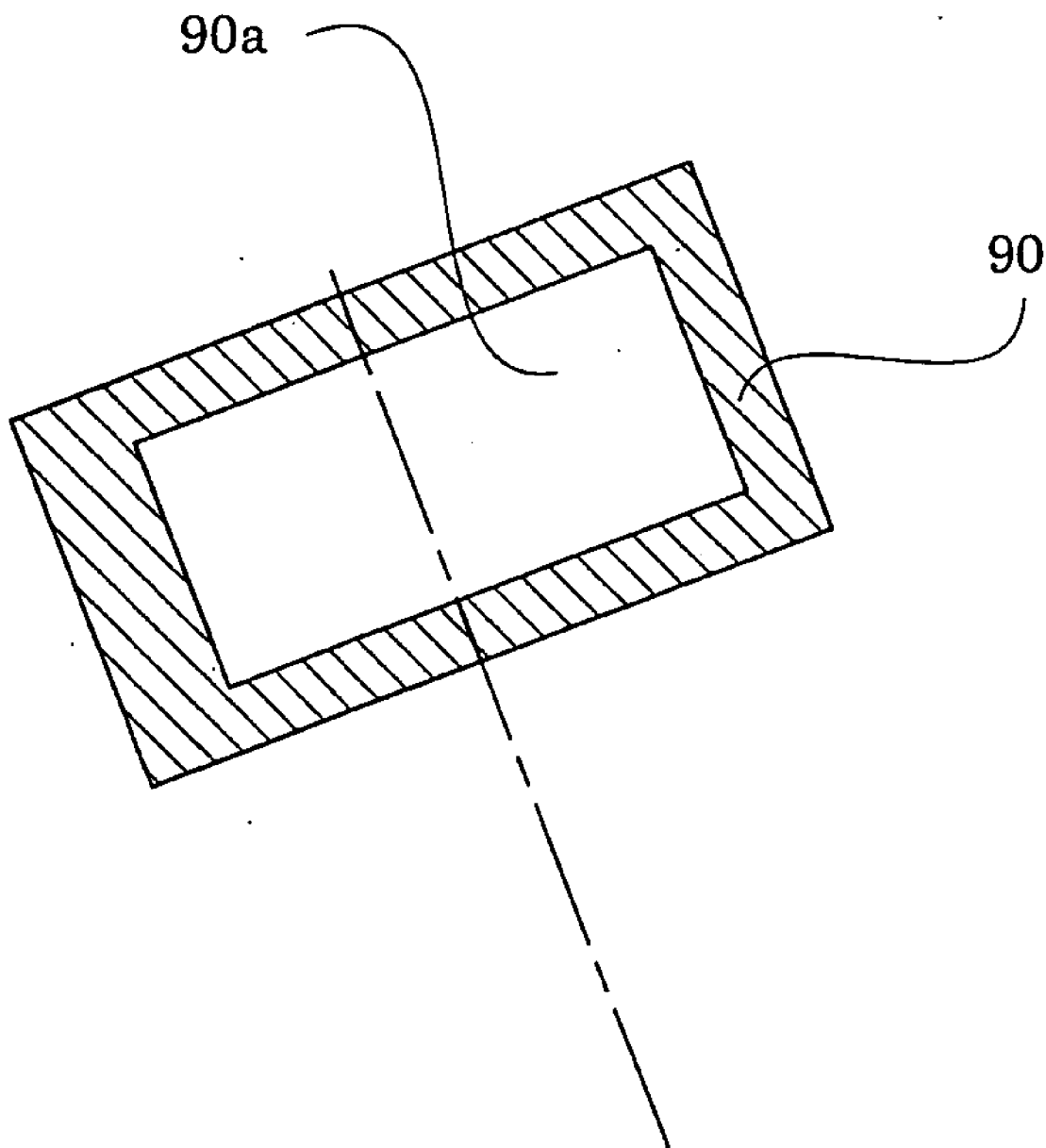

Fig.33



SURVEYING INSTRUMENT

[0001] This is a divisional of U.S. application Ser. No. 09/978,542 filed on Oct. 18, 2001, the content of which is expressly incorporated by reference herein in its entirety.

BACKGROUND OF THE INVENTION

[0002] 1. Field of the Invention

[0003] The present invention relates to a surveying instrument having a sighting telescope, and more specifically relates to a surveying instrument having a sighting telescope which is equipped with a device for preventing a ghost image from being formed in the field of view of the sighting telescope.

[0004] 2. Description of the Related Art

[0005] A conventional surveying instrument such as a total station has a function to measure the distance between two points and also horizontal and vertical angles. Such a conventional surveying instrument generally measures the distance between two points with an electronic distance meter (EDM) incorporated in or attached to the surveying instrument. The electronic distance meter incorporates an optical distance meter which calculates the distance via the phase difference between projecting light and reflected light and via the initial phase of internal reference light, or via the time difference between the projecting light and the reflected light. The optical distance meter includes a light-transmitting optical system for transmitting a measuring light (projecting light) to the target (sighting object) via the objective lens of a sighting telescope (collimating telescope) provided as a component of the electronic distance meter, and a light-receiving optical system for receiving light (reflected light) reflected by the target.

[0006] Among conventional surveying instruments having such an electronic distance meter, a surveying instrument whose electronic distance meter employs a prism having a dichroic mirror (wavelength selection mirror) that serves as a beam-splitting optical system is known in the art. Such a prism having a dichroic mirror is hereinafter referred to as a "dichroic prism". The dichroic mirror reflects light with specific wavelengths while allowing light with other wavelengths to pass through. The dichroic prism is disposed between the objective lens and the eyepiece of the sighting telescope so that the measuring light, which is emitted by a light emitting element, is reflected by the dichroic mirror of the dichroic prism to be projected toward the target (sighting object) via the objective lens of the sighting telescope. The light which is reflected by the target and passed through the objective lens is selectively reflected by the dichroic mirror to travel to a light-receiving element.

[0007] On the other hand, advancements have been made in the development of surveying instruments provided with a sighting telescope having an autofocus system, wherein a phase-difference detection autofocus system is widely used. With this system, an in-focus state is detected based on the correlation between two images formed by two light bundles which are respectively passed through two different pupil areas of an objective lens of the sighting telescope.

[0008] The applicants of the present invention have proposed a surveying instrument in Japanese laid-open publication No. 10-73772 (U.S. Pat. No. 5,877,892), in which one

of the first through fourth reflection surfaces of a Porro prism is formed as a semitransparent mirror to divide the incident light path into two optical paths: a first optical path for the phase-difference detection autofocus system, and a second optical path for the sighting telescope.

[0009] However, in the above described conventional surveying instruments having a sighting telescope, especially with a Porro prism, a ghost image (or a flare spot), which is caused by off-field light (non-image forming light), is seen through the eyepiece of the sighting telescope. If such off-field light enters the autofocus system via the aforementioned semitransparent mirror, the performance of the autofocus system deteriorates.

SUMMARY OF THE INVENTION

[0010] An object of the present invention is to provide a surveying instrument, wherein the performance of each of the sighting telescope and the focus detecting device of the surveying instrument is fully utilized by preventing a ghost image from being formed in the field of the sighting telescope optical system.

[0011] To achieve the object mentioned above, according to an aspect of the present invention, a surveying instrument is provided, including a sighting telescope having an objective lens and an eyepiece; an erecting optical system functioning so that an image formed by the objective lens is viewed as an erect image through the eyepiece; and a light shield device, positioned in an optical path extending from an incident surface of the erecting optical system to an exit surface of the erecting optical system, for preventing an off-field light bundle which is incident on the erecting optical system from reaching the eyepiece.

[0012] In an embodiment, the light shield device includes a light shield mask or plate fixed to the incident surface of the erecting optical system.

[0013] In an embodiment, the light shield mask includes an aperture which allows image forming light to pass therethrough, the aperture being shaped so as to be asymmetrical with respect to an optical axis incident on the incident surface of the erecting optical system.

[0014] In an embodiment, a first length of the aperture from the incident optical axis to a first side, at which an optical path length between the incident surface and a first reflection surface of the erecting optical system is shortest, is shorter than a second length of the aperture from the incident optical axis to a second side at which an optical path length between the incident surface and the first reflection surface is longest.

[0015] In an embodiment, the erecting optical system includes two cemented prisms, and wherein the light shield device includes a recessed portion formed on a common edge of the cemented surface of the two cemented prisms.

[0016] In an embodiment, the erecting optical system includes two cemented prisms, and wherein the light shield device includes a beveled surface formed on a common edge of the cemented surface of the two cemented prisms.

[0017] In an embodiment, the light shield device is formed by an extended portion of the erecting optical system on the incident surface thereof, the extended portion being deformed to extend toward the objective lens side so that the

off-field light bundle which is reflected by a first reflection surface of the erecting optical system is prevented from being incident on a second reflection surface of the erecting optical system and being allowed to exit from the erecting optical system via the extended portion.

[0018] In an embodiment, the erecting optical system includes a semitransparent film formed on a first reflection surface of the erecting optical system, wherein light incident on the first reflection surface is transmitted through the semitransparent film to proceed toward a focus detecting device which detects a focus state of the sighting telescope.

[0019] The erecting optical system can include a Porro prism or a roof prism.

[0020] According to another aspect of the present invention, a surveying instrument is provided, including a sighting telescope having an objective lens and an eyepiece; a semitransparent film positioned between the objective lens and the eyepiece; a focus detecting device which receives light which is passed through the semitransparent film to detect a focus state of the sighting telescope; and a light shield device, positioned in an optical path extending from the semitransparent film to the focus detecting device, for preventing an off-field light bundle which is incident on the semitransparent film from reaching the focus detecting device.

[0021] In an embodiment, the surveying instrument further includes an erecting optical system functioning so that an image formed by the objective lens is viewed as an erect image through the eyepiece, the semitransparent film being formed on a reflection surface of the erecting optical system.

[0022] In an embodiment, the light shield device is a light shield mask fixed to an incident surface of the erecting optical system.

[0023] In an embodiment, the surveying instrument further includes a beam splitting prism which is provided separately from the erecting optical system and cemented to the semitransparent film, the light shield device being fixed to the beam splitting prism.

[0024] In an embodiment, the semitransparent film is formed on a first reflection surface of the erecting optical system, the beam splitting prism being cemented to the first reflection surface wherein the semitransparent film being positioned between the beam splitting prism and the first reflection surface.

[0025] In an embodiment, the semitransparent film is formed on a second reflection surface of the erecting optical system, the beam splitting prism being cemented to the second reflection surface wherein the semitransparent film being positioned between the beam splitting prism and the second reflection surface.

[0026] In an embodiment, the surveying instrument includes an erecting optical system functioning so that an image formed by the objective lens is viewed as an erect image through the eyepiece, and a beam splitting prism provided separately from the erecting optical system; wherein the semitransparent film is formed on the beam splitting prism.

[0027] In an embodiment, the light shield device is fixed to an exit surface of the beam splitting prism.

[0028] The focus detecting device can be a phase-difference detection focus detecting device or a contrast detecting focus detecting device.

[0029] The erecting optical system can include a Porro prism or a roof prism.

[0030] Preferably, the sighting telescope includes a focus adjustment lens positioned between the objective lens and the erecting optical system.

[0031] Preferably, the beam splitting prism includes a right-angle prism.

[0032] Preferably, the Porro prism includes three right angle prisms.

[0033] The present disclosure relates to subject matter contained in Japanese Patent Application No. 2000-319117 (filed on Oct. 19, 2000) which is expressly incorporated herein by reference in its entirety.

BRIEF DESCRIPTION OF THE DRAWINGS

[0034] The present invention will be described below in detail with reference to the accompanying drawings in which:

[0035] FIG. 1 is a schematic drawing of an embodiment of an electronic distance meter having a focus detecting device, according to the present invention;

[0036] FIG. 2 is a cross sectional view of fundamental optical elements of the electronic distance meter shown in FIG. 1, taken along II-II line in FIG. 1, viewed in the direction of the appended arrows;

[0037] FIG. 3 is a plan view of a switching-mirror drive mechanism provided in the electronic distance meter shown in FIG. 1, viewed in the direction of an arrow III in FIG. 1;

[0038] FIG. 4 is a conceptual diagram of the focus detecting device (AF sensor unit), as viewed in the direction of an arrow IV shown in FIG. 1;

[0039] FIG. 5 is a perspective view of the Porro prism and the focal-plane plate shown in FIG. 1;

[0040] FIG. 6 is an explanatory view illustrating off-field light in the electronic distance meter shown in FIG. 1;

[0041] FIG. 7 is an explanatory view illustrating the off-field light bundle shown in FIG. 6;

[0042] FIG. 8 is a fragmentary diagram of the electronic distance meter shown in FIG. 1 and illustrates another off-field light bundle which travels in a different direction;

[0043] FIG. 9 is a side elevational view of a fundamental portion of the electronic distance meter shown in FIG. 1, illustrating the first embodiment of a ghost image formation preventing device according to the present invention;

[0044] FIG. 10 is a front elevational view of a fundamental portion of the ghost image formation preventing device shown in FIG. 9, as viewed in the direction of an arrow X shown in FIG. 9;

[0045] FIG. 11 is a side elevational view similar to that of FIG. 9, illustrating the second embodiment of the ghost image formation preventing device according to the present invention;

[0046] FIG. 12 is a perspective view of the Porro prism and the focal-plane plate shown in FIG. 11;

[0047] FIG. 13 is a side elevational view of another embodiment of a fundamental portion of the second embodiment of the ghost image formation preventing device shown in FIG. 11;

[0048] FIG. 14 is a side elevational view similar to that of FIG. 9 and illustrates the third embodiment of the ghost image formation preventing device according to the present invention;

[0049] FIG. 15 is a perspective view of the Porro prism and the focal-plane plate shown in FIG. 14;

[0050] FIG. 16 is a side elevational view of another embodiment of a fundamental portion of the third embodiment of the ghost image formation preventing device shown in FIG. 14;

[0051] FIG. 17 is a side elevational view similar to that of FIG. 9, illustrating the fourth embodiment of the ghost image formation preventing device according to the present invention;

[0052] FIG. 18 is a perspective view of the Porro prism and the focal-plane plate shown in FIG. 17;

[0053] FIG. 19 is a side elevational view similar to that of FIG. 9, illustrating the fifth embodiment of the ghost image formation preventing device according to the present invention;

[0054] FIG. 20 is a plan view of a light shield mask provided in a Porro prism shown in FIG. 19, viewed in the direction of arrows X in FIG. 19;

[0055] FIG. 21 is a plan view of another light shield mask provided in the Porro prism shown in FIG. 19, viewed in the direction of arrows Y in FIG. 19;

[0056] FIG. 22 is a view similar to that of FIG. 9 and illustrates the sixth embodiment of the ghost image formation preventing device according to the present invention;

[0057] FIG. 23 is a rear elevational view of a fundamental portion of the ghost image formation preventing device shown in FIG. 22, viewed in the direction of an arrow P shown in FIG. 22;

[0058] FIG. 24 is a plan view of a light shield mask provided in a Porro prism shown in FIG. 22, viewed in the direction of arrows Q in FIG. 22;

[0059] FIG. 25 is a plan view of another light shield mask provided in the Porro prism shown in FIG. 22, viewed in the direction of arrows R in FIG. 23;

[0060] FIG. 26 is a side elevational view similar to that of FIG. 9, illustrating the seventh embodiment of the ghost image formation preventing device according to the present invention;

[0061] FIG. 27 is a side elevational view similar to that of FIG. 26, illustrating the eighth embodiment of the ghost image formation preventing device according to the present invention;

[0062] FIG. 28 is a plan view of a light shield mask provided in the Porro prism shown in FIG. 22, viewed in the direction of arrows S in FIG. 27;

[0063] FIG. 29 is a perspective view of an embodiment of a roof prism serving as an erecting optical system which can be replaced with the Porro prism used in each of the first through eighth embodiments of the ghost image formation preventing devices;

[0064] FIG. 30 is a side elevational view of another embodiment of a fundamental portion of the first embodiment of the ghost image formation preventing device shown in FIG. 9, showing the case where the Porro prism shown in FIG. 9 is replaced by the roof prism shown in FIG. 28;

[0065] FIG. 31 is a side elevational view of another embodiment of a fundamental portion of the second embodiment of the ghost image formation preventing device shown in FIG. 11, showing the case where the Porro prism shown in FIG. 11 is replaced by the roof prism shown in FIG. 28; and

[0066] FIG. 32 is a side elevational view of another embodiment of a fundamental portion of the fifth embodiment of the ghost image formation preventing device shown in FIG. 19, showing the case where the Porro prism shown in FIG. 19 is replaced by the roof prism shown in FIG. 28;

[0067] FIG. 33 is a plan view of a light shield mask provided in the roof prism shown in FIG. 32, viewed in the direction of arrows T in FIG. 32.

DESCRIPTION OF THE PREFERRED EMBODIMENTS

[0068] FIG. 1 shows an embodiment of an electronic distance meter (EDM) equipped with an autofocus system, according to the present invention. This electronic distance meter can be incorporated in or attached to a surveying instrument such as a total station. The electronic distance meter is provided with a sighting telescope (sighting telescope optical system) 10 and an optical distance meter 20. As shown in FIGS. 1 and 2, the sighting telescope 10 is provided with an objective lens 11, a focusing lens 12, a Porro prism (erecting optical system) 13, a focal-plane plate (reticle plate) 14, and an eyepiece 15, in that order from the object side (i.e., left to right as shown in FIG. 1). The focal-plane plate 14 is provided thereon with a reticle (cross hair) 16. The focusing lens 12 is guided in the direction of an optical axis X of the sighting telescope 10. The image of a corner cube prism (i.e., a sighting object placed at a point of measurement) 17 that is formed through the objective lens 11 can be precisely focused on the front surface (the surface facing the objective lens 11) of the focal-plane plate 14 by adjusting the axial position of the focusing lens 12 in accordance with the distance of the corner cube prism 17 with respect to the sighting telescope 10. The Porro prism 13 functions so that the image of the corner cube prism 17 is viewed as an erect image through the eyepiece 15. The user (surveyor) of the surveying instrument sights a magnified image of the corner cube prism 17, which is focused on the focal-plane plate 14, via the eyepiece 15.

[0069] The electronic distance meter is provided between the objective lens 11 and the focusing lens 12 with a cubic dichroic prism 21 that serves as a beam-splitting optical system. The dichroic prism 21 is constructed from two right-angle prisms which are cemented to each other. The dichroic prism 21 is provided with a dichroic mirror 21a (wavelength selection mirror) which is formed on a bound-

ary surface between the two right-angle prisms. The dichroic prism 21 is an element of the optical distance meter 20, and is fixedly positioned behind the objective lens 11 via a fixing device (not shown). The dichroic prism 21 is provided therein with the aforementioned dichroic mirror 21a which reflects light with specific wavelengths while allowing others to pass therethrough. The dichroic prism 21 is positioned on the optical axis X so that the dichroic mirror 21a is inclined to a plane perpendicular to the optical axis X by 45 degrees.

[0070] The optical distance meter 20 is provided above the dichroic prism 21, in FIG. 1, with a light-emitting element (laser diode) 23. The light-emitting element 23 emits light (measuring light) having a specific wavelength within the range of wavelengths of the light which is reflected by the dichroic mirror 21a of the dichroic prism 21. The measuring light (externally-projecting light) emitted from the light-emitting element 23 is reflected by the dichroic mirror 21a to be projected toward the corner cube prism 17 via the objective lens 11. The light-emitting element 23 and the dichroic mirror 21a are elements of a light-transmitting optical system of the optical distance meter 20. The measuring light which is reflected by the corner cube prism 17 and passed through the objective lens 11 is reflected by the dichroic mirror 21a again. At this time, the wavelengths of the light bundles incident upon the dichroic mirror 21a, which are not within the range of wavelengths of the light which is reflected by the dichroic mirror 21a, pass through the dichroic mirror 21a.

[0071] A right-angle prism 22 which is an element of the optical distance meter 20 is disposed between the light-emitting element 23 and the dichroic prism 21. The right-angle prism 22 is positioned on one side (the upper side as viewed in FIG. 3) of a plane F (see FIG. 3) which includes the central axis of a light bundle incident on a light-receiving element 31 and the central axis of a light bundle emitted from the light-emitting element 23. Accordingly, the portion of the light bundle, emitted from the light-emitting element 23, which does not interfere with the right-angle prism 22 is made incident on the dichroic mirror 21a of the dichroic prism 21. Thereafter, the measuring light which is reflected by the dichroic mirror 21a and incident on a reflection surface 22a of the right-angle prism 22 is reflected by the reflection surface 22a to be incident on the light-receiving element 31. The dichroic mirror 21a, the reflection surface 22a and the light-receiving element 31 are elements of a light-receiving optical system of the optical distance meter 20.

[0072] The electronic distance meter is provided with a switching prism 28 and a first ND filter 29 between the right-angle prism 22 and the light-emitting element 23, on a distance-measuring optical path. As shown in FIG. 3, the switching prism 28 can rotate about a pivot 28a between an advanced position (the position shown by a two-dot chain line in FIG. 3) and a retracted position (the position shown by a solid line in FIG. 3). The light emitted by the light-emitting element 23 is incident on a first fixed mirror 24a and is reflected thereby to be incident as an internal reference light on the light-receiving element 31 via a second fixed mirror 24b when the switching prism 28 is positioned in the advanced position. On the other hand, the light emitted by the light-emitting element 23 is incident directly on the dichroic prism 21 when the switching prism 28 is positioned

in the retracted position. The first ND filter 29 is used to adjust the amount of the measuring light incident on the corner cube prism 17.

[0073] The electronic distance meter is provided between the right-angle prism 22 and the light-receiving element 31, on a distance-measuring optical path, with a second ND filter 32 and a band-pass filter 34, in that order from the right-angle prism 22 to the light-receiving element 31. The light-receiving element 31 is connected to a controller (calculation control circuit) 40. The controller 40 is connected to an actuator 41 which drives the switching prism 28, and an indicating device (e.g., an LCD panel) 42 which indicates the calculated distance.

[0074] As known in the art, the optical distance meter 20 establishes two different states: one state wherein light emitted by the light-emitting element 23 is supplied to the dichroic prism 21 as the measuring light, and another state wherein the light is supplied to the fixed mirror 24a as the internal reference light, which are determined in accordance with the switching state of the switching prism 28 driven by the controller 40 via the actuator 41. As described above, the measuring light supplied to the dichroic prism 21 is projected toward the corner cube prism 17 via the dichroic mirror 21a and the objective lens 11, and the measuring light reflected by the corner cube prism 17 is incident on the light-receiving element 31 via the objective lens 11, the dichroic mirror 21a, the reflection surface 22a, the second ND filter 32 and the band-pass filter 34. The controller 40 detects the phase-difference between the projecting light and the reflected light, and the initial phase of the internal reference light which is supplied to the light-receiving element 31 via the switching prism 28, the first fixed mirror 24a, and the second fixed mirror 24b, or the time difference between the projecting light and the reflected light, to calculate the distance from the electronic distance meter to the corner cube prism 17. The calculated distance is indicated by the indicating device 42. Such an operation of calculating the distance is well known in the art.

[0075] The present embodiment of the electronic distance meter is provided with a phase-difference detection AF sensor unit (phase-difference detection focus detecting device) 50 which is positioned appropriately with respect to the light path reflected by a reflection surface of the Porro prism 13. As shown in FIG. 5, the Porro prism 13 is of a type which employs three right angle prisms having six rectangular surfaces: an incident surface 13a, first through fourth reflection surfaces 13b, 13c, 13d and 13e, and an exit surface 13f, in that order from the incident light side. A semitransparent film is formed on the first reflection surface 13b so as to serve as a semitransparent mirror. The incident surface 13a extends perpendicular to an optical axis 13X (of the focusing lens 12) incident on the incident surface 13a. A portion of the light incident on the incident surface 13a is reflected downwards by the first reflection surface 13b at an angle of 90 degrees. The light reflected by the first reflection surface 13b is reflected by the second reflection surface 13c so that the optical axis reflected from the second reflection surface 13c extends normal (i.e., at an angle of 90 degrees in a direction to the left as viewed in FIG. 4) to a plane defined by the optical axis incident on the first reflection surface 13b and the optical axis incident on the second reflection surface 13c. The light reflected by the second reflection surface 13c is reflected upwards by the third

reflection surface **13d** at an angle of 90 degrees. The light reflected by the third reflection surface **13d** is reflected rearwards by the fourth reflection surface **13e** at an angle of 90 degrees to proceed in a direction parallel to the incident light on the incident surface **13a**. The light reflected by the fourth reflection surface **13e** exits from the exit surface **13f** to be incident on the focal-plane plate **14**. The exit surface **13f** extends perpendicular to an optical axis **13Y** emerging from the exit surface **13f**. The eyepiece **15** is positioned on the optical axis **13Y**.

[0076] A beam splitting prism (a right-angle prism) **18** is cemented to the semitransparent film formed on the first reflection surface **13b**. The right-angle prism **18** is provided with an incident surface **18a**, a reflection surface **18b** and an exit surface **18c**. The incident surface **18a** is cemented to the semitransparent film formed on the first reflection surface **13b**. The reflection surface **18b** extends perpendicular to the incident surface **18a** and reflects the incident light thereon upwards, normal to the exit surface **18c**. The light reflected by the reflection surface **18b** exits from the exit surface **18c** to proceed toward the AF sensor unit **50**. Accordingly, the light which is passed through the first reflection surface **13b** and the incident surface **18a** is projected toward the AF sensor unit **50** via the reflection surface **18b** and the exit surface **18c**, while the light which is reflected by the first reflection surface **13b** is projected toward the eyepiece **15** via the second, third and fourth reflection surfaces **13c**, **13d** and **13e**, and the exit surface **13f** of the Porro prism **13**.

[0077] FIG. 4 shows a conceptual diagram of the AF sensor unit **50**. A reference focal plane **51** is provided between the Porro prism **13** and the AF sensor unit **50**, and is located at a position optically equivalent to the position at which the reticle **16** of the focal-plane plate **14** is placed. The AF sensor unit **50** detects the focus state (amount of defocus and direction of focal shift) on the reference focal plane **51**. The AF sensor unit **50** includes a condenser lens **52**, a pair of separator lenses **53**, and a pair of line sensors (e.g., multi segment CCD sensors) **54** located behind the respective separator lenses **53**. The pair of separator lenses **53** are arranged apart from each other by the base length. The image of the corner cube prism **17** formed on the reference focal plane **51** is separated into two images by the pair of separator lenses **53** to be respectively formed on the pair of line sensors **54**. Each of the pair of line sensors **54** includes an array of photoelectric converting elements. Each photoelectric converting element converts the received light thereon into electric charges which are integrated (accumulated), and outputs as an integrated electric charge to the controller **40** to constitute AF sensor data. The controller **40** calculates an amount of defocus through a predetermined defocus operation in accordance with a pair of AF sensor data respectively input from the pair of line sensors **54**. In an autofocus operation, the controller **40** drives the focusing lens **12** to bring the corner cube prism **17** into focus via a lens drive motor **19** (see FIG. 1) in accordance with the calculated amount of defocus. The defocus operation is well-known in the art. An AF start switch **44** and a distance-measurement operation start switch **45** are connected to the controller **40**.

[0078] The AF sensor unit **50** detects an in-focus state from the pair of images respectively formed on the pair of line sensors **54** by two light bundles **11A** and **11B** which are respectively passed through two different pupil areas (not

shown) on the objective lens **11**. The shape of each of the two pupil areas can be determined by the shape of the aperture formed on corresponding one of a pair of separator masks **55** which are respectively positioned in the vicinity of the pair of separator lenses **53** between the condenser lens **52** and the pair of separator lenses **53**.

[0079] FIGS. 6 and 7 are explanatory views similar to those of FIGS. 1 and 5 in regard to off-field light (non-image forming light) which causes a ghost image (or a flare spot). If an off-field light bundle **60**, a principal ray of which is shown by one-dot chain line in FIG. 6, is incident on the objective lens **11** at a point on the front surface thereof in the vicinity of the maximum effective aperture of the objective lens **11**, and is subsequently incident on the incident surface **13a** of the Porro prism **13** in the vicinity of an end of the incident surface **13a** by a specific angle in a manner as shown in FIG. 6, the off-field light bundle **60** is reflected by the first reflection surface **13b** to return to the incident surface **13a**. This returned off-field light bundle **60** is totally reflected by the incident surface **13a** to form an image on the focal-plane plate **14** in the vicinity of the center thereof. This image is seen as a ghost image in the field of view of the sighting telescope **20** via the eyepiece **15**. The ghost image tends to be seen easily especially when the intensity of the off-field light bundle **60** is high. A principal ray of a central light bundle **63** which is incident on the front surface of the objective lens **11** along the optical axis thereof and is subsequently incident on the incident surface **13a** of the Porro prism **13** at the center thereof is shown in FIG. 5 for comparison with the off-field light bundle **60**.

[0080] In a state where the first reflection surface **13b** does not split the incident light (i.e., if semitransparent film is not formed on the first reflection surface **13b**), the image-forming light traveling in the field of the sighting telescope optical system is totally reflected by the first reflection surface **13b** since the image-forming light is incident on the first reflection surface **13b** at an angle equal to or greater than the critical angle (e.g., approximately 41 degrees in the case of using BK7), while the off-field light bundle **60** mostly passes through the first reflection surface **13b** (approximately five percent of the off-field light bundle **60** is reflected by the first reflection surface **13b**) since the off-field light bundle **60** is incident on the first reflection surface **13b** at an angle smaller than the critical angle. Therefore, the off-field light bundle **60** has little effect on the object image seen through the eyepiece. However, with the semitransparent film on the first reflection surface **13b**, the reflectivity of the first reflection surface **13b** increases. For example, even if the off-field light bundle **60** is incident on the first reflection surface **13b** at an angle smaller than the critical angle, due to the increased reflectivity of the first reflection surface **13b**, it is possible for the off-field light bundle **60** to be reflected thereby. If the Porro prism **13** is sufficiently large with respect to the effective aperture of the objective lens **11**, the off-field light bundle **60** can be reflected by one or more sides of the Porro prism **13** but does not enter the field of the sighting telescope optical system. However, surveying instruments are required to be compact and easy to carry, which inevitably miniaturizes the Porro prism **13**. If the Porro prism **13** is small in size, an off-field light bundle which travels in a specific direction is totally reflected by the incident surface **13a** of the Porro prism **13** after having been reflected by the first reflection surface **13b** thereof to be formed as a ghost image seen through the

eyepiece. As a result, two images overlap each other to thereby deteriorate the performance (e.g., a resolution) of the sighting telescope. Moreover, the off-field light bundle **60** which partly passes through the first reflection surface **13b** and reaches the AF sensor unit **50** has the adverse effect of deteriorating the precision of the AF sensor unit **50**.

[0081] FIG. 8 shows a principal ray of another off-field light bundle **61** which travels in a direction different from that of the above described off-field light bundle **60** to discuss problems of the off-field light bundle **61**. The off-field light bundle **61** is incident on the Porro prism **13** in a direction which is symmetrical to the direction of the off-field light bundle **60** with respect to the optical axis X. The off-field light bundle **61** is repeatedly reflected by a side **13g** of the Porro prism **13**, and therefore has little effect on the object image seen through the eyepiece **15**. However, it is preferable that such reflections of the off-field light bundle **61** not exist. Each of all the sides of the Porro prism **13** except the incident surface **13a**, the first and fourth reflection surfaces **13b** through **13e** and the exit surface **13f** is preferably formed as a matt surface.

[0082] Specific problems for the case where the first reflection surface **13b** of the Porro prism **13** is formed as a semitransparent mirror used for detecting a focus have been discussed-above. However, even if the Porro prism **13** is not provided with a semitransparent mirror (i.e., even if the electronic distance meter is not provided with a focus detection system), an off-field light bundle sometimes causes a ghost image. In addition, if there is an object which gives off light of a high intensity, an adverse effect in the field of view of the sighting telescope occurs if one of the reflection surfaces of the Porro prism **13**, except the first reflection surface **13b** thereof, is formed as a semitransparent mirror serving as a beam splitter.

[0083] The present embodiment of the electronic distance meter is equipped with a ghost image formation preventing device for preventing the formation of the above described ghost images. More specifically, the present embodiment of the electronic distance meter is provided, in an optical path extending from the incident surface **13a** to the exit surface **13f** of the Porro prism **13**, with a light shield device for preventing off-field light bundles which is incident on the Porro prism **13** from reaching the AF sensor unit **50**, or is provided, in an optical path extending from the first reflection surface **13b** to the AF sensor unit **50**, with a light shield device for preventing off-field light bundles which is incident on the first reflection surface **13b** from reaching the AF sensor unit **50**.

[0084] FIGS. 9 through 21 show the first through six embodiments of the ghost image formation preventing devices. In each of these embodiments, a semitransparent film is formed on the first reflection surface **13b** so as to serve as a semitransparent mirror. More specifically, the beam splitting prism **18** is cemented to the semitransparent film formed on the first reflection surface **13b**.

[0085] FIGS. 9 and 10 show the first embodiment of the ghost image formation preventing device. In this embodiment, a light shield plate **70** having an aperture **70a** is disposed immediately in front of the incident surface **13a** of the Porro prism **13** to prevent off-field light bundle **60** from entering into the Porro prism **13**. Only the light which is passed through the aperture **70a** is allowed to enter into the

Porro prism **13**. The above described off-field light bundle **60**, shown by a two-dot chain line in FIG. 6, has a greater adverse effect on the field of view of the sighting telescope **20** as the optical path length from the incident surface **13a** to the first reflection surface **13b** is shorter. To prevent this problem from occurring, in the first embodiment shown in FIGS. 9 and 10, the aperture **70a** of the light shield plate **70** is shaped to be asymmetrical with respect to the optical axis **13X** as shown in FIG. 10, while the light shield plate **70** is provided, immediately above the substantially-circular shaped aperture **70a**, with a light shield portion **70b** which makes the shape of the aperture **70a** imperfect circle. With the light shield portion **70b**, a radial length R1 (see FIG. 10) of the aperture **70a** from the optical axis **13X** to a side of the aperture **70a** (the upper side as viewed in FIGS. 9 and 10), where the optical path length between the incident surface **13a** and the first reflection surface **13b** in the horizontal direction as viewed in FIG. 9 is the shortest, is shorter than a radial length R2 from the optical axis **13X** to the other side (the lower side as viewed in FIGS. 9 and 10) of the aperture **70a** where the optical-path length between the incident surface **13a** and the first reflection surface **13b** in the horizontal direction as viewed in FIG. 9 is the longest. In other words, an area of the aperture **70a** above a horizontal line intersecting the optical axis **13x** at right angles is smaller than the remaining area of the aperture **70a** below the horizontal line.

[0086] FIGS. 11 and 12 show the second embodiment of the ghost image formation preventing device. In this embodiment, the Porro prism **13** includes a first prism **13-1** having the incident surface **13a** and the first reflection surface **13b**, a second prism **13-2** having the second and third reflection surfaces **13c** and **13d**, and a third prism **13-3** having the fourth reflection surface **13e** and the exit surface **13f**. The first prism **13-1** and the third prism **13-3** are each cemented to the second prism **13-2**. The Porro prism **13** is provided, on a common edge of the cemented surface of the first prism **13-1** and the second prism **13-2**, with a recessed portion so that it is positioned in an optical path of the off-field light bundle **60**. In the embodiment shown in FIG. 12, a recessed portion **81** is formed on the first prism **13-1**. As shown in FIG. 13, a recessed portion **81'** corresponding to the recessed portion **81** can be formed on the second prism **13-2**. The recessed portion may be formed on both of the first prism **13-1** and the second prism **13-2**.

[0087] FIGS. 14 and 15 show the third embodiment of the ghost image formation preventing device. The third embodiment is the same as the above described second embodiment except that the Porro prism **13** is provided, on a common edge of the cemented surface of the first prism **13-1** and the second prism **13-2**, with a beveled surface instead of the recessed portion of the second embodiment. In the embodiment shown in FIG. 15, the beveled surface **82** is formed on the first prism **13-1** along the edge of the cemented surface, i.e. the edge of the first prism **13-1** is beveled. As shown in FIG. 16, a beveled surface **82'** corresponding to the beveled surface **82** can be formed on the second prism **13-2**.

[0088] According to each of the second and third embodiments, the off-field light bundle **60** which reaches the recessed portion **81** (**81'**) or the beveled surface **82** (**82'**) after being reflected by the first reflection surface **13b** does not proceed further therefrom, and therefore does not reach the AF sensor unit **50** or the eyepiece lens **15**. It is preferable

that the surface of each of the recessed portion **81** (**81'**) and the beveled surface **82** (**82'**) be formed as a matt surface, e.g., coated with a matt coating.

[0089] FIGS. 17 through 18 show the fourth embodiment of the ghost image formation preventing device. In this embodiment, the first prism **13-1** is shaped to extend forward (leftward as viewed in FIG. 17) so that the incident surface **13a** becomes closer to the focusing lens **12**. With this structure, the off-field light bundle **60** which is reflected by the first reflection surface **13b** is not incident on the second reflection surface **13c**, but exits from the bottom of the forwardly-extended portion of the first prism **13-1**. The bottom surface of the forwardly-extended portion of the first prism **13-1** can be coated with a matt coating so as to reflect, diffuse or absorb the incident light thereon. As is clearly shown in FIG. 17, the first prism **13-1** of this embodiment is formed to extend toward the focusing lens **12** so that the respective upper ends of the incident surface **13a** and the first reflection surface **13b** are not connected to each other but are apart from each other by a distance *d*.

[0090] Each of the above described first through fourth embodiments can be combined with another one or more embodiments if necessary. Furthermore, the Porro prism **13** can be provided, on each bonding surface among the first through third prisms **13-1**, **13-2** and **13-3**, with a light shield mask for preventing the off-field light bundle from entering the field of view of the sighting telescope **20**.

[0091] FIGS. 19 through 27 show the fifth through eighth embodiments of the ghost image formation preventing devices. Each of the fifth through eighth embodiments is constructed so that the off-field light bundle **60** which is passed through a reflection surface of the Porro Prism **13** does not reach the AF sensor unit **50**.

[0092] FIGS. 19 through 21 show the fifth embodiment of the ghost image formation preventing device. In this embodiment, a semitransparent film is formed on the first reflection surface **13b** so as to serve as a beam splitter. Moreover, a rectangular light shield mask **90** (see FIG. 20) having an elongated rectangular aperture **90a** is fixed between the first reflection surface **13b** and the incident surface **18a** of the right-angle prism **18**. Furthermore, a similar light shield mask **90** (see FIG. 21) is fixed to the exit surface **18c**. The light shield mask **90** provided between the first reflection surface **13b** and the incident surface **18a** reflects, absorbs or diffuses the incident light thereon. If the shape of the aperture **90a** is determined so that only the two light bundles **11A** and **11B** (see FIG. 4) which are respectively passed through two different pupil areas of the AF sensor unit **50** can pass through the aperture **90a**, not only the off-field light bundle **60** but any other stray light can be cut off to ensure accuracy of the AF sensor unit **50**. The hatched portions shown in FIGS. 20 and 21 show a portion (light interception member) other than the aperture **90a**.

[0093] FIGS. 22 through 25 show the sixth embodiment of the ghost image formation preventing device. In this embodiment, a semitransparent film is formed on the second reflection surface **13c** so as to serve as a beam splitter, and a right-angle prism **18'** is cemented to the semitransparent film formed on the second reflection surface **13c**. Moreover, a light shield mask **90** (see FIGS. 24 and 25) having an elongated rectangular aperture **90a**, which is identical to that in the above described fifth embodiment, is fixed between

the second reflection surface **13d** and an incident surface **18d** of the right-angle prism **18'**, while the same light shield mask **90** is fixed to an exit surface **18e** of the right-angle prism **18'**. Accordingly, it can be freely determined which of the reflection surfaces of the Porro prism **13** is formed as a semitransparent mirror. The light shield mask **90** can be positioned to correspond to the position of the semitransparent mirror and/or the position of the exit surface of the right-angle prism **18** or **18'** that is cemented to the semitransparent mirror. The shape of the aperture **90a** of the light shield mask **90** is identical to that of the light shield mask **90** shown in FIGS. 20 and 21.

[0094] FIG. 26 shows the seventh embodiment of the ghost image formation preventing device. In this embodiment, a beam splitting prism **95** that is provided independently from the Porro prism **13** is disposed in front of the Porro prism **13**. A semitransparent film **95a** is formed on the beam splitting prism **95** to reflect part of the incident light on the semitransparent film **95a** toward the AF sensor unit **50**. The beam splitting prism **95** is provided on an exit surface **95b** thereof (the upper surface as viewed in FIG. 26) with a raised transparent portion **95c** and a non-transparent peripheral portion **95d** whose surface is formed as a matt surface (e.g., coated with a matt coating).

[0095] FIG. 27 shows the eighth embodiment of the ghost image formation preventing device. This embodiment is to the same as the seventh embodiment shown in FIG. 26 except that the beam splitting prism **95** of the eighth embodiment is provided on an exit surface **95b** thereof (the upper surface as viewed in FIG. 27) with a light shield mask **90** (see FIG. 28) having the elongated rectangular aperture **90a**, which is to the same as that in the above described each of fifth and sixth embodiments, not with the raised transparent portion **95c** and the non-transparent peripheral portion **95d**. In FIG. 28, the hatched portion shows a portion (light interception member) other than the aperture **90a**.

[0096] In the seventh embodiment shown in FIG. 26, the shape of the raised transparent portion **95c** can be determined to correspond to the shape of the elongated rectangular aperture **90a** of the light shield mask **90**. According to each of the seventh and eighth embodiments, the off-field light bundle **60** is effectively prevented from entering the AF sensor unit **50**, which ensures accuracy of the AF sensor unit **50**.

[0097] Each of the above described first through eighth embodiments of the ghost image formation preventing devices employs the Porro prism **13** as an erecting optical system. FIGS. 29 through 32 show ninth through eleventh embodiments of the ghost image formation preventing device. Each of the ninth through eleventh embodiments employs a Schmidt prism **130**, including a roof prism, shown in FIG. 29 as an erecting optical system instead of the Porro prism **13**. The Schmidt prism **130** has an incident surface **130a**, first through sixth reflection surfaces **130b** through **130f** and an exit surface **130g** as shown in FIGS. 29 and 30. The fourth reflection surface is a roof surface. A semitransparent film is formed on the second reflection surface **130c** so that it serves as a beam splitter. The incident surface **130a** extends perpendicular to an optical axis **130X**. The light incident on the incident surface **130a** is reflected upwards by the first reflection surface **130b** at an angle of 90 degrees. Part of the light reflected by the first reflection

surface **130b** is reflected by the second reflection surface **130c** at an angle of 45 degrees in a direction toward the third reflection surface **130d** (in a direction oblique and lower rightward as viewed in **FIG. 29**). The light reflected by the second reflection surface **130c** is reflected by the third reflection surface **130d** at an angle of 90 degrees in a direction oblique and lower leftward as viewed in **FIG. 29**. The light reflected by the third reflection surface **130d** is reflected by the fourth reflection surface **130e** at an angle of 90 degrees in a direction toward the fifth reflection surface **130f** (in a direction oblique and lower rightward as viewed in **FIG. 29**). The light reflected by the fourth reflection surface **130e** is reflected by the fifth reflection surface **130f** at an angle of 90 degrees to exit from the exit surface **130g** to proceed toward the AF sensor unit **50**. The exit surface **130g** and the third reflection surface **130d** are defined on the same plane, and extend perpendicular to an optical axis **130Y2**. The optical axis **130Y2** is parallel to the optical axis **130X**. A specific surface of a beam splitting prism (a right-angle prism) **18** is cemented to the semitransparent film formed on the second reflection surface **130c**. The light which is reflected by the first reflection surface **130b** and is subsequently passed through the second reflection surface **130c** proceeds toward the AF sensor unit **50** along an optical axis **130Y1**.

[0098] **FIG. 30** shows the ninth embodiment of the ghost image formation preventing device. In this embodiment, a light shield plate **70** having an aperture **70a** and a light shield portion **70b**, which is similar to the light shield plate **70** shown in **FIGS. 9 and 10**, is disposed immediately in front of the incident surface **130a** of the roof prism **130** to prevent the off-field light bundle **60** from entering into the Schmidt prism **130**.

[0099] **FIG. 31** shows the tenth embodiment of the ghost image formation preventing device. In this embodiment, a recessed portion **181** is provided in the roof prism **130** between the Schmidt prism **130** and the beam splitting prism **18** along an edge therebetween, and is positioned in an optical path of the off-field light bundle **60**.

[0100] **FIG. 32** shows the eleventh embodiment of the ghost image formation preventing device. In this embodiment, a semitransparent film is formed on the second reflection surface **130c** so as to serve as a beam splitter. Furthermore, a light shield mask **90** shown in **FIG. 33** having the elongated rectangular aperture **90a**, which is to the same as that in the above described fifth or six embodiment, is fixed to the second reflection surface **130c** to be positioned between the second reflection surface **130c** and the incident surface **18a** of the beam splitting prism **18**. In **FIG. 33**, the hatched portion shows a portion (light interception member) other than the aperture **90a**.

[0101] In each of the ninth through eleventh embodiments of the ghost image formation preventing devices, the off-field light bundle **60** which is incident on the Schmidt prism **130** reaches neither the eyepiece **15** nor the AF sensor unit **50**.

[0102] In each of the above described first through eleventh embodiments of the ghost image formation preventing devices, although the AF sensor unit **50** is a phase-difference detection type, the AF sensor unit **50** can be replaced with any other type such as a contrast detecting type. The present embodiment of the electronic distance meter can be incor-

porated in or attached to not only a total station, but also any other surveying instrument having a surveying telescope such as a theodolite. Furthermore, the erecting optical system is not limited to those in the above-described embodiments.

[0103] The present embodiment of the electronic distance meter performs a distance measuring operation in a manner such as described in the following description. In the first step, a surveyor (user) aims the sighting telescope **10** at the corner cube prism **17** so that the optical axis X of the sighting telescope **10** is generally in line with the corner cube prism **17**, while viewing the corner cube prism **17** through a collimator (not shown) which is attached to the sighting telescope **10**. In the second step, the surveyor depresses the AF start switch **44** to perform the aforementioned autofocus operation to move the focusing lens **12** to an in-focus position (in-focus state) thereof relative to the corner cube prism **17**. In the third step, in a state where the sighting telescope **10** is in focus relative to the corner cube prism **17**, the surveyor adjusts the direction of the sighting telescope **10** so that the reticle (cross hair) **15** viewed through the eyepiece **15** is precisely centered on the corner cube prism **17** while looking into the eyepiece **15**. In the fourth step, the surveyor depresses the distance-measurement operation start switch **45** to perform the aforementioned distance-calculating operation, wherein the calculated distance is indicated on the indicating device **42**.

[0104] As can be understood from the foregoing, according to a ghost image formation preventing device of a surveying instrument to which the present invention is applied, a ghost image is prevented from being formed in the field of the sighting telescope optical system. Furthermore, in the case of the surveying instrument equipped with a focus detecting device, a focus detecting operation can be performed with a high degree of precision.

[0105] Obvious changes may be made in the specific embodiments of the present invention described herein, such modifications being within the spirit and scope of the invention claimed. It is indicated that all matter contained herein is illustrative and does not limit the scope of the present invention.

What is claimed is:

1. A surveying instrument comprising:

- a sighting telescope having an objective lens and an eyepiece;
- a semitransparent film positioned between said objective lens and said eyepiece;
- a focus detecting device which receives light which is passed through said semitransparent film to detect a focus state of said sighting telescope; and
- a light shield device, positioned in an optical path extending from said semitransparent film to said focus detecting device, for preventing an off-field light bundle which is incident on said semitransparent film from reaching said focus detecting device.

2. The surveying instrument according to claim 1, further comprising an erecting optical system functioning so that an image formed by said objective lens is viewed as an erect

image through the eyepiece, said semitransparent film being formed on a reflection surface of said erecting optical system.

3. The surveying instrument according to claim 2, wherein said light shield device comprises a light shield mask fixed to an incident surface of said erecting optical system.

4. The surveying instrument according to claim 2, further comprising a beam splitting prism which is provided separately from said erecting optical system and cemented to said semitransparent film, said light shield device being fixed to said beam splitting prism.

5. The surveying instrument according to claim 4, wherein said semitransparent film is formed on a first reflection surface of said erecting optical system, said beam splitting prism being cemented to said first reflection surface wherein said semitransparent film being positioned between said beam splitting prism and said first reflection surface.

6. The surveying instrument according to claim 4, wherein said semitransparent film is formed on a second reflection surface of said erecting optical system, said beam splitting prism being cemented to said second reflection surface wherein said semitransparent film being positioned between said beam splitting prism and said second reflection surface.

7. The surveying instrument according to claim 4, wherein said beam splitting prism comprises a right-angle prism.

8. The surveying instrument according to claim 1, further comprising an erecting optical system functioning so that an image formed by said objective lens is viewed as an erect image through the eyepiece; and

a beam splitting prism provided separately from said erecting optical system;

wherein said semitransparent film is formed on said beam splitting prism.

9. The surveying instrument according to claim 8, wherein said light shield device is fixed to an exit surface of said beam splitting prism.

10. The surveying instrument according to claim 8, wherein said beam splitting prism comprises a right-angle prism.

11. The surveying instrument according to claim 1, wherein said focus detecting device comprises a phase-difference detection focus detecting device.

12. The surveying instrument according to claim 1, wherein said focus detecting device comprises a contrast detecting focus detecting device.

13. The surveying instrument according to claim 1, wherein said erecting optical system comprises a Porro prism.

14. The surveying instrument according to claim 13, wherein said Porro prism comprises three right angle prisms.

15. The surveying instrument according to claim 1, wherein said erecting optical system comprises a roof prism.

16. The surveying instrument according to claim 1, wherein said sighting telescope comprises a focus adjustment lens positioned between said objective lens and said erecting optical system.

* * * * *