

(No Model.)

W. A. TURNER.
BALL COCK VALVE.

No. 520,150.

Patented May 22, 1894.

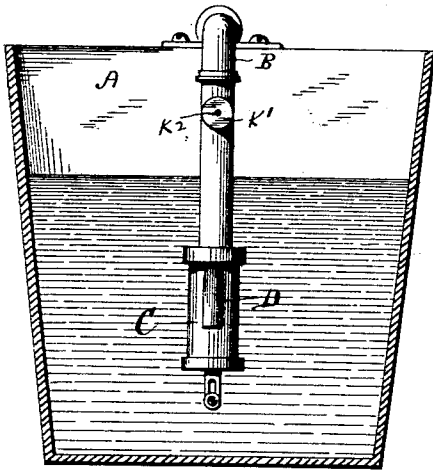

Fig. 1.

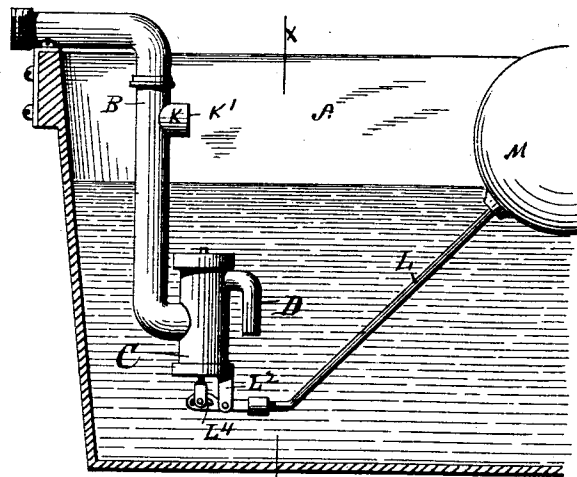

Fig. 2.

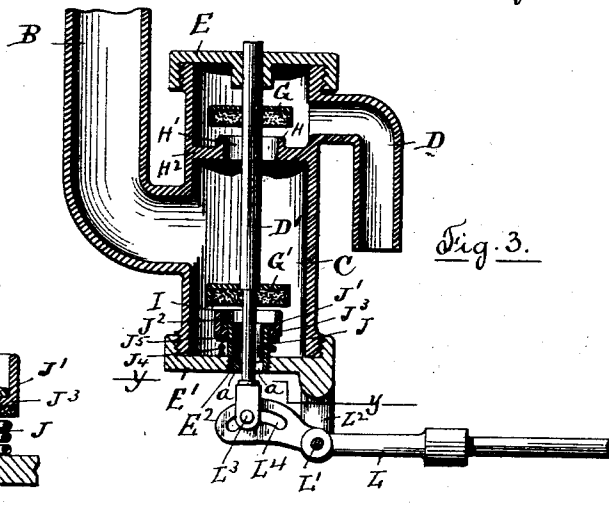

Fig. 3.

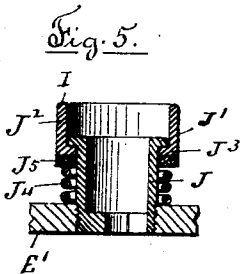

Fig. 5.

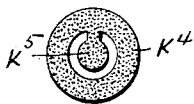

Fig. 7.

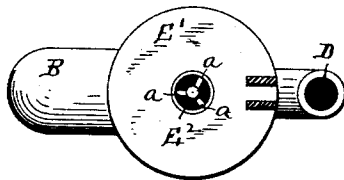

Fig. 4.

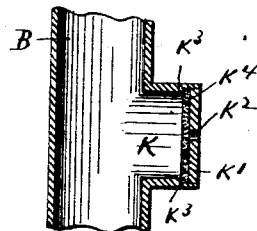

Fig. 6.

Witnesses

Chas. F. Schmelz,

Rufus B. Fowler,

Inventor

William A. Turner.

UNITED STATES PATENT OFFICE.

WILLIAM A. TURNER, OF WORCESTER, MASSACHUSETTS, ASSIGNOR TO
EDMUND CONVERSE, OF SAME PLACE.

BALL-COCK VALVE.

SPECIFICATION forming part of Letters Patent No. 520,150, dated May 22, 1894.

Application filed October 17, 1889. Serial No. 327,325. (No model.)

To all whom it may concern:

Be it known that I, WILLIAM A. TURNER, a citizen of the United States, and a resident of Worcester, in the county of Worcester and State of Massachusetts, have invented a new and useful Improvement in Ball-Cock Valves, of which the following is a specification, accompanied by drawings, which represent a ball-cock valve embodying my invention, and in which—

Figure 1 represents a transverse sectional view of a flushing tank containing one of my improved ball cock valves. Fig. 2 is a longitudinal sectional view of the same. Fig. 3 is a vertical central sectional view of the valve. Fig. 4 is a bottom and sectional view on line Y—Y Fig. 3. Fig. 5 is an enlarged central sectional view of the yielding valve seat. Fig. 6 is a central sectional view of the valve for preventing siphonage of the flushing tank, and Fig. 7 represents a detached view of the elastic packing and valve tongue of the valve shown in sectional view in Fig. 6.

Similar letters refer to similar parts in the several figures.

The object of my invention is to produce a balanced valve, or one in which the valve stem can be operated independently of the pressure of the water upon the valve disks, also to provide for an increased flow of water into the flushing tank and further to modify the action of the valve stem so as to secure an accelerated movement of the valve disks in closing the valve, and these objects I attain through and by means of the mechanism illustrated in the accompanying drawings, and hereinafter described.

Referring to the accompanying drawings, A denotes an ordinary flushing tank; B the supply pipe through which water is admitted to the tank.

C is the shell or case inclosing the valve chamber and placed at the lower end of the supply pipe and beneath the water line.

D is a bent outlet pipe forming one of the passages through which the water passes from the valve chamber to the tank and is preferably bent to impart a downward flow to the current of water.

E, E' are the heads of the shell C, the upper head E having an opening forming a bear-

ing for the valve stem F, and the lower head E' is provided with an opening E² forming a second outlet from the valve chamber to the tank.

The lower section of the valve stem D is provided with wings a, a, a, Fig. 4, extending radially from the valve stem with their outer edges bearing against the wall of the opening E², and forming a bearing for the valve stem in the lower head E'. To the valve stem are attached the two valve disks G, G', as shown in Fig. 3, the upper disk is arranged, as the valve stem is lowered, to rest upon the valve seat H and close the water way H' through the partition H², preventing the flow of water through the water way H' and outlet pipe D, in like manner the downward movement of the valve stem brings the valve disk G' upon the yielding valve seat I, closing the opening E² to the passage of water.

By a careful adjustment of the distances between the faces of the valve seats and the opposing faces of the valve disks the apparatus can be made to operate, but I prefer to make one of the valve seats, to yield as the valve disk is brought into contact with it and to so arrange the distance between the valve disks that the yielding valve seat will be first brought into contact with its valve disk, and as the downward movement of the valve stem is continued the seat is made to yield in order to allow the upper valve disk to be brought in contact with the other valve seat.

I do not confine myself to the specific construction as shown of the yielding seat, but I have represented in the drawings one form of construction, which I deem efficient for the purpose.

J is a sleeve which is screwed into the head E' surrounding the opening E². The upper end of the sleeve J is provided with a flange J', to limit the upward movement of the valve seat I, which is an annular ring J² with its upper edge forming the seat for the valve disk and with its lower edge provided with a flange J³ turned inwardly to engage the outwardly turned flange J' upon the sleeve J. Between the flange J³ and the head E' is placed a spiral spring J⁴ with its tension applied to force the seat upward and maintain the two flanges in contact. As the pressure

of the valve disk is brought against the valve seat I the annular ring J² is pushed downward compressing the spiral spring J⁴, and permitting the continued movement of the valve stem D. In order to prevent the flow of water between the annular ring J² and the sleeve J, I place an elastic washer or packing J⁵ against the lower edge of the ring J².

In order to prevent the siphonage of the tank A through the supply pipe I make an opening in the side of the supply pipe at K, which is closed by a disk K' having an air hole or vent K². The wall of the opening at K is provided with a shoulder K³, and between the shoulder K³ and the disk K' is placed the elastic washer K⁴, provided with the valve tongue K⁵, closing the vent K². Whenever water is drawn from the supply pipe outside the tank and at a point lower than the tank the valve tongue will yield to allow air to enter through the vent K³ and prevent the siphonage of the tank. The vent K² can be placed at any convenient point above the water line in the tank.

The valve stem can be raised and lowered by any of the means for that purpose, but the method shown is convenient and effectual, and consists of a lever L pivoted at L' to a bracket L² extending from the shell C. To the long arm of the lever L, I attach the hollow ball M, which is raised by the water in the tank and falls by its own gravity as the water line is lowered. The short arm of the lever L is provided with a curved slot L⁴, entering the lower and forked end of the valve stem, which carries a pin L³ passing through the slot L⁴.

The slot L⁴ is so shaped that as the ball M is raised by the water in the tank the valve disks are brought down upon their respective seats with an accelerated movement causing the rapid closing of the valve disks upon their seats as the ball approaches the high water line in the tank, thereby preventing the continued "wire-drawing" of the stream of water as the valve disks are closing the water ways.

I am aware that a valve stem has been actuated by means of a ball lever provided with a slot and engaging the valve stem; I therefore do not claim such; but I believe it to be new to employ a ball lever provided with a

cam shaped slot by which an accelerated movement is given to the valve stem as the ball approaches the high water line in the tank.

What I claim as my invention, and desire to secure by Letters Patent, is—

1. The combination with a valve chamber having openings on opposite sides forming water ways, of a valve stem, capable of an endwise movement, two valve disks attached to said valve stem, and arranged to close said openings or water ways, a yielding valve seat surrounding one of said openings, and comprising a sleeve held in the shell inclosing the valve chamber, an annular ring inclosing said sleeve, said sleeve and ring having opposing flanges, and a spiral spring with its tension applied to said annular ring, as described, and a fixed valve seat, surrounding the other water way, substantially as described.

2. The combination with a valve having openings on opposite sides, forming water ways, of a valve stem capable of an endwise movement, two valve disks attached to said valve stem and arranged to close said openings, or water ways, a yielding valve seat surrounding one of said openings and comprising a sleeve held in the shell inclosing the valve chamber, an annular ring inclosing said sleeve, said sleeve and ring having opposing flanges, a spiral spring with its tension applied to said annular ring as described, a fixed valve seat surrounding the other water way, a pivoted lever provided with a hollow ball arranged to be raised and lowered by the variation of the water line in the tank, said lever being provided with a cam slot, operatively connected with said valve stem, said cam slot being so shaped that the valve stem is moved endwise to close the valve disks with an accelerated movement, substantially as described.

3. The combination with the supply pipe of a ball cock valve, of an air vent or opening above the water line in the tank, whereby air is admitted to prevent the siphonage of the tank, substantially as described.

Dated this 15th day of October, 1889.

WILLIAM A. TURNER.

Witnesses:

E. CONVERSE,
RUFUS B. FOWLER.