

No. 773,903.

PATENTED NOV. 1, 1904.

H. N. THAYER.
WHEEL HUB.

APPLICATION FILED JAN. 30, 1904.

NO MODEL.

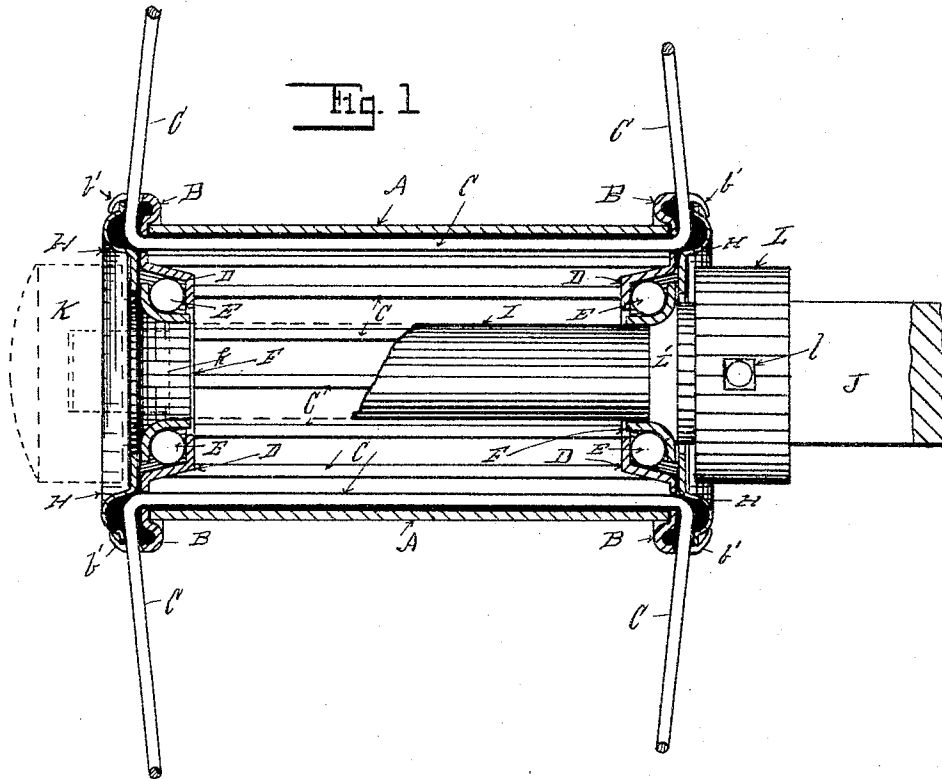

Fig. 2.

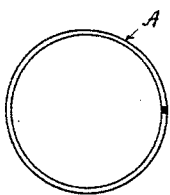

Fig. 3.

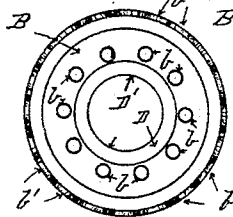

Fig. 4.

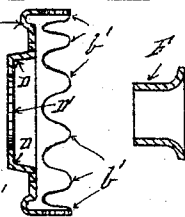

Fig. 5.



Fig. 6.

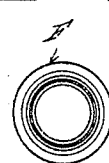
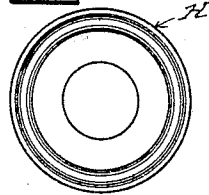

Fig. 7.



Fig. 8.



Witnesses:

G. J. Mudd
F. J. Barrett

Inventor:

Horace N. Thayer
By J. P. + N. M. Sturgeon
Attys

UNITED STATES PATENT OFFICE.

HORACE N. THAYER, OF ERIE, PENNSYLVANIA.

WHEEL-HUB.

SPECIFICATION forming part of Letters Patent No. 773,903, dated November 1, 1904.

Application filed January 30, 1904. Serial No. 191,362. (No model.)

To all whom it may concern:

Be it known that I, HORACE N. THAYER, a citizen of the United States, residing at Erie, in the county of Erie and State of Pennsylvania, have invented certain new and useful Improvements in Wheel-Hubs; and I do hereby declare the following to be a full, clear, and exact description of the invention, such as will enable others skilled in the art to which it appertains to make and use the same, reference being had to the accompanying drawings, and to the letters of reference marked thereon, forming a part of this specification.

My invention relates to vehicle-wheel hubs, and particularly to such wheel-hubs provided with ball-bearings so constructed and arranged that the wheel-hub and ball-bearings thereof are self-contained and complete in all of their operative parts ready to be placed upon an axle. In accomplishing this result I preferably construct the parts of the wheel-hub of pressed or stamped sheet metal in such shape that when put together and the spokes inserted the hub-thimble and heads thereon provided with ball-races therein are firmly secured together ready to receive the balls and loose thimble-cones forming the ball-bearings thereof, which when inserted are held in place by the insertion into the heads of a collar which is secured therein by crimping down the edges of the heads over the peripheries of said collars, so that all of the parts thereof are secured together ready for the insertion of an axle therein, which axle is provided with adjustable collars fitting into and engaging the thimble-cones in the wheel-hub.

The features of this invention are herein-after fully set forth and described, and illustrated in the accompanying drawings, in which—

Figure 1 shows a longitudinal central section of my improved wheel-hub with a section of an axle therein. Fig. 2 is an end view of the hub-thimble. Fig. 3 is an end view of one of the heads fitting upon the ends of said thimble. Fig. 4 is a vertical central section of the same. Fig. 5 is a vertical section of the hollow thimble-cones. Fig. 6 is an end view of the same. Fig. 7 is a vertical section

of the collar fitting into the head, Fig. 3. Fig. 8 is an end view of the same.

In the drawings, A, Figs. 1 and 2, is a thimble forming the shell of the hub, and B, B, Figs. 1, 3, and 4, are the heads fitting against the ends of the thimble A and secured thereto by wire spokes C, passed through holes *b* in the heads B and bent upward between the outwardly-projecting ears *b'*, as clearly illustrated in Fig. 1, which firmly secures the heads B upon the ends of the thimble A. These heads B are provided with annular ball channels or races D, in which balls E can be inserted, and with central openings D', adapted to receive thimble-shaped cones F, Figs. 5 and 6, which cones F, are secured loosely therein by collars H, Figs. 7 and 8, which collars are then secured in place in the heads B B by pressing down the ears *b'* on the heads over the periphery of the collar H, as illustrated in Fig. 1. The hub and ball-bearings therein are thus all secured together, forming a complete and self-contained ball-bearing wheel-hub ready for use.

The application of this wheel-hub to an axle is as follows: The spindle I of the axle J passes loosely through the loose thimble-cones F and is provided on its outer end with a nut K, provided with a collar *k*, (shown in dotted lines,) adapted to enter the outer end of the thimble-cone F, which nut K is screwed tightly thereon, as shown in dotted lines in Fig. 1. On the rear end of the spindle I there is an adjustable collar L, provided with a set-screw *l* for securing it upon the axle J. This collar is then moved toward the wheel-hub until it fits tightly into the thimble-cone F, so that the two thimble-cones at each end of the hub are firmly held and supported upon the collar *k* of the nut K and the collar L' of the collar L and at the same time pressing the cones F F against the balls E, as illustrated in Fig. 1, so that the hub will rotate freely thereon.

Having thus shown and described my invention, so as to enable others to construct and use the same, what I claim as new, and desire to secure by Letters Patent of the United States, is—

1. The combination in a wheel-hub, of hub-

heads formed of sheet metal, there being ball-
channels in and peripheral ears on said heads,
balls in said ball-channels, loose hollow thim-
ble-cones forming the inner bearings of said
5 balls and retaining them in the ball-channels,
and sheet-metal collars secured to the ends of
the hub by means of the ears on the periphery
of the hub for retaining the thimble-cones in
place, substantially as set forth.
10 2. The combination in a wheel-hub of a
thimble forming the shell of the hub, heads on
the ends of the thimble provided with ball-
channels and with ears on the peripheries

thereof, balls in said ball-channels, hollow
loose thimble-cones supporting the balls in 15
the channels in the heads, and collars in the
ends of the heads secured therein by the in-
wardly-extending ears on the heads, substan-
tially as set forth.

In testimony whereof I affix my signature in 20
presence of two witnesses.

HORACE N. THAYER.

Witnesses:

H. M. STURGEON,
G. J. MEAD.