



- (51) **International Patent Classification:**
E21D 11/15 (2006.01)
- (21) **International Application Number:**
PCT/US2013/060106
- (22) **International Filing Date:**
17 September 2013 (17.09.2013)
- (25) **Filing Language:** English
- (26) **Publication Language:** English
- (30) **Priority Data:**
61/704,067 21 September 2012 (21.09.2012) US
- (71) **Applicant (for all designated States except US):**
CONTECH ENGINEERED SOLUTIONS LLC
[US/US]; 9025 Centre Pointe Drive, Suite 400, West
Chester, OH 45069 (US).
- (72) **Inventor; and**
(71) **Applicant (for US only): SANDERS, Darrell, J.**
[US/US]; 6050 Bethany Road, Mason, OH 45040 (US).
- (74) **Agents: NIEBERDING, Michael, J. et al.;** Thompson
Hine LLP, 10050 Innovation Drive, Suite 400, Dayton, OH
45342-4934 (US).
- (81) **Designated States (unless otherwise indicated, for every
kind of national protection available):** AE, AG, AL, AM,

AO, AT, AU, AZ, BA, BB, BG, BH, BN, BR, BW, BY,
BZ, CA, CH, CL, CN, CO, CR, CU, CZ, DE, DK, DM,
DO, DZ, EC, EE, EG, ES, FI, GB, GD, GE, GH, GM, GT,
HN, HR, HU, ID, IL, IN, IS, JP, KE, KG, KN, KP, KR,
KZ, LA, LC, LK, LR, LS, LT, LU, LY, MA, MD, ME,
MG, MK, MN, MW, MX, MY, MZ, NA, NG, NI, NO, NZ,
OM, PA, PE, PG, PH, PL, PT, QA, RO, RS, RU, RW, SA,
SC, SD, SE, SG, SK, SL, SM, ST, SV, SY, TH, TJ, TM,
TN, TR, TT, TZ, UA, UG, US, UZ, VC, VN, ZA, ZM,
ZW.

- (84) **Designated States (unless otherwise indicated, for every
kind of regional protection available):** ARIPO (BW, GH,
GM, KE, LR, LS, MW, MZ, NA, RW, SD, SL, SZ, TZ,
UG, ZM, ZW), Eurasian (AM, AZ, BY, KG, KZ, RU, TJ,
TM), European (AL, AT, BE, BG, CH, CY, CZ, DE, DK,
EE, ES, FI, FR, GB, GR, HR, HU, IE, IS, IT, LT, LU, LV,
MC, MK, MT, NL, NO, PL, PT, RO, RS, SE, SI, SK, SM,
TR), OAPI (BF, BJ, CF, CG, CL, CM, GA, GN, GQ, GW,
KM, ML, MR, NE, SN, TD, TG).

Published:

- with international search report (Art. 21(3))
- before the expiration of the time limit for amending the
claims and to be republished in the event of receipt of
amendments (Rule 48.2(h))

- (54) **Title:** LOW PROFILE MINE SHAFT LINER PLATE SYSTEM AND METHOD

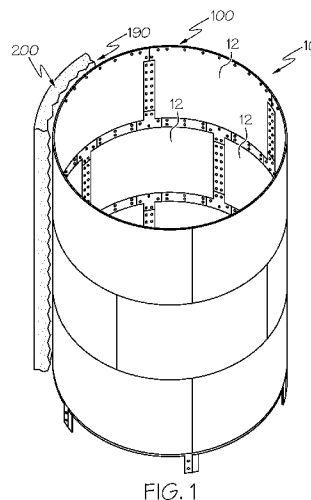

FIG. 1

- (57) **Abstract:** A liner plate system for lining shafts or tunnels is provided. The system includes a plurality of curved liner plate units and a plurality of line lock plates. Each curved liner plate unit includes a radially outer side and a radially inner side, the radially inner side including a peripherally extending seal recess having a seal material thereon. Each liner lock plate has an inner side and an outer side, the outer side including a seal recess formed therein, the seal recess having a seal material thereon. The curved liner plate units and the liner lock plates arranged to form a curved wall structure.



LOW PROFILE MINE SHAFT LINER PLATE SYSTEM AND METHOD

CROSS-REFERENCES

[0001] This application claims the benefit of U.S. provisional application Serial No. 61/704,067, filed September 21, 2012, which is incorporated herein by reference.

TECHNICAL FIELD

[0002] This application relates generally to liner systems for vertical mine shafts and underground tunnels and, more particularly, to a low profile liner plate system and method for providing a waterproof shaft or tunnel.

BACKGROUND

[0003] Vertical mine shafts often encounter issues with water penetration, particularly when one or more vertical sections of the mine shaft pass through porous ground water containing layers. Prior attempts to address this issue include cast iron tubing, welded steel panels, composite bolted systems and others. However, such technologies have proven expensive and timely to install.

[0004] PCT Publication No. WO 2011/097201 discloses a mine shaft liner plate system with a sealing arrangement, where the plates include a primary plate portion surrounded by flanges, and the primary plate portion includes a structural member at its radial outer side for added strength. The described plate system is particularly useful for installations in new mine shafts.

[0005] Many existing, older mine shafts have a concrete based shaft seal system, which was typically poured-in-place. Over tens of years the concrete system begins to degrade. The current method for upkeep is to periodically shut down the mine (e.g., once a year for several weeks), chip out the aged/worn concrete and replace it with new concrete or, in some cases, install a welded steel liner in the chipped out region and the back grout along the radially outer side of the line. However, this process is very time consuming and, therefore, costly.

[0006] Accordingly, it would be desirable and advantageous to provide a more economical system and method of sealing vertical mine shafts, and particularly rehabilitating vertical mine shafts and other types of tunnels.

SUMMARY

[0007] In one aspect, a method of rehabilitating a vertical mine shaft bounded by a concrete wall structure is provided. The method involves: removing an interior portion of

the concrete wall structure; and installing a liner plate system adjacent the concrete wall structure including: utilizing a plurality of arcuate liner plate units, each arcuate liner plate unit including a radially outer side and a radially inner side, the radially inner side including a peripherally extending seal recess having a seal material thereon, the seal material having an uncompressed radial thickness greater than a radial depth of the seal recess so as to protrude beyond a primary inner surface of the radially inner side; utilizing a plurality of liner lock plates, each lock plate having an inner side and an outer side, the outer side including a seal recess formed therein, the seal recess having a seal material thereon, the seal material having an uncompressed thickness greater than a depth of the seal recess so as to protrude beyond a primary outer surface of the outer side; arranging the arcuate liner plate units and the liner lock plates to form a cylindrical wall structure, with a first set of arcuate liner plate units forming a first ring and a second set of arcuate liner plate units forming a second ring, the first ring having a top edge, bottom edge and multiple vertical edge joints, the second ring having a top edge, bottom edge and multiple vertical edge joints, the top edge of the first ring abutting a bottom edge of the second ring to form a lateral edge joint, the vertical edge joints of the first ring circumferentially offset from the vertical edge joints of the second ring, the liner lock plates positioned along an inner side of the cylindrical wall structure with the seal material of the liner lock plates in contact with the seal material of the arcuate liner plate units; and utilizing threaded members to hold the liner lock plates adjacent the arcuate liner plate units such that the cylindrical wall structure formed by the combination of the liner lock plates and the arcuate liner plate units is a rigid, unitary structure.

[0008] In one implementation, each lock plate includes a plurality of openings therein, the threaded members are either mount studs welded to the radially inner side of the arcuate liner plate unit or bolts threadedly inserted into threaded openings at the radially inner side of the arcuate liner plate unit, in either case each threaded member passes through a respective one of the lock plate openings.

[0009] In one implementation, the liner lock plates include multiple T-shaped lock plates, where the ends of the T-shape are spaced apart from each other when the T-shaped lock plates are joined to the arcuate liner plate units.

[0010] In one implementation, the liner lock plates include multiple splice plates interconnecting the T-shaped lock plates, the splice plates including vertically oriented splice plates and laterally oriented splice plates.

[0011] In one implementation, each end of each T-shaped lock plate includes a recessed mating region at its radially inner side, each end of each splice plate includes a recessed mating region at its radially outer side, and the recessed mating regions of the T-shaped lock plates overlap the recessed mating regions of the splice plates.

[0012] In one implementation, the seal recess of each T-shaped lock plate extends to each end thereof; the seal recess of each splice plate extends from one recessed mating region of the splice plate to the other recessed mating region of the splice plate, and the ends of the T-shaped lock plate seal recesses are adjacent the ends of the splice plate seal recesses.

[0013] In one implementation, the liner lock plates include multiple intermediate plates connected between spaced apart T-shaped lock plates, the intermediate plates including vertically oriented intermediate plates and laterally oriented intermediate plates, each end of each T-shaped lock plate is positioned proximate to or in abutment with an end of an adjacent intermediate plate without any overlap between the T-shaped lock plates and the intermediate plates.

[0014] In one implementation, each T-shaped lock plate covers a portion of one of the vertical edge joints and a portion of the lateral edge joint.

[0015] One implementation includes the further step of applying a chemical weld activator coating to seal members of the arcuate liner plate units and/or seal members of the locking plates so that when two seal members engage each other they become welded together.

[0016] One implementation includes the further step of performing a backgrouting operation at the radially outer side of the liner plate system to provide continuity between the liner plate system and the concrete wall structure.

[0017] In another aspect, a liner plate system for lining shafts or tunnels is provided. The system includes a plurality of curved liner plate units and a plurality of liner lock plates. Each curved liner plate unit includes a radially outer side and a radially inner side, the radially inner side including a peripherally extending seal recess having a seal material thereon. Each liner lock plate has an inner side and an outer side, the outer side including a seal recess formed therein, the seal recess having a seal material thereon. The curved liner plate units and the liner lock plates are arranged to form a curved wall structure. The curved liner plates form multiple rings, each ring having a first end edge, a second end edge and multiple interior edge joints. The rings are arranged end to end such that abutting

end edges form multiple end edge joints. The interior edge joints of each ring are circumferentially offset from the interior edge joints of each adjacent ring. The liner lock plates are secured along an inner side of the curved wall structure with the seal material of the liner lock plates pressed into contact with the seal material of the curved liner plate units in order to seal both the end edge joints between adjacent rings and the interior edge joints of each ring.

[0018] In one implementation, a plurality of threaded members secure the liner lock plates to the curved liner plate units, wherein each liner lock plate includes a plurality of openings therein and through which a respective one of the threaded members extends.

[0019] In one implementation, the threaded members are formed by threaded mount studs extending inwardly from the radially inner sides of the curved liner plate units and nuts on the mount studs hold the liner lock plates adjacent the curved liner plate units and compress the seal material therebetween.

[0020] In one implementation, each of the curved liner plate units includes a plurality of threaded holes and the threaded members are formed by bolts, each bolt extending through a respective one of the liner lock plate openings and into a respective one of the threaded holes to hold the liner lock plates adjacent the curved liner plate units and compress the seal material therebetween.

[0021] In one implementation, the seal material of the curved liner plate units is chemically welded to the seal material of the liner lock plates.

[0022] In one implementation, the seal recess of each liner lock plate aligns with side by side seal recesses of the curved liner plate units such that the seal material of the seal recess of each liner lock plate is pressed into contact with seal material of at least two curved liner plate units.

[0023] In one implementation, the liner lock plates include multiple T-shaped lock plates, where ends of the T-shape are spaced apart from each other when the T-shaped lock plates are joined to the curved liner plate units.

[0024] In one implementation, the liner lock plates include multiple splice plates interconnecting the T-shaped lock plates, each end of each T-shaped lock plate includes a recessed mating region at its radially inner side, each end of each splice plate includes a recessed mating region at its radially outer side, and the recessed mating regions of the T-shaped lock plates overlap the recessed mating regions of the splice plates.

[0025] In one implementation, the liner lock plates include multiple intermediate

plates connected between spaced apart T-shaped lock plates, and each end of each T-shaped lock plate is positioned proximate to or in abutment with an end of an adjacent intermediate plate without any overlap between the T-shaped lock plates and the intermediate plates.

[0026] In one implementation, multiple seal joints are formed between ends of the T-shaped lock plates and adjacent ends of the intermediate plates, at each seal joint seal material of the T-shaped lock plate and seal material of the intermediate plate is compressed to create an abutting and sealing contact therebetween.

[0027] In one implementation, each T-shaped lock plate covers a portion of one of the interior edge joints and a portion of one of the end edge joints.

BRIEF DESCRIPTION OF THE DRAWINGS

[0028] Fig. 1 is a perspective view a cylindrical liner plate arrangement;

[0029] Fig. 2 is a partial perspective view of the liner plate arrangement of Fig. 1 with a portion of the cylindrical wall cut away;

[0030] Fig. 3 is a partial perspective view of an arcuate liner plate;

[0031] Fig. 4 shows a plan view of a flat plate that is used to form the arcuate liner plate of Fig. 3;

[0032] Fig. 5 is a side elevation view of the plate of Fig. 4;

[0033] Fig. 6 is a partial view of an edge portion of the plate of Fig. 3;

[0034] Fig. 7 is a plan view of a T-shaped locking plate laid flat (e.g., prior to curving);

[0035] Fig. 8 is a side elevation view of the plate of Fig. 7;

[0036] Fig. 9 is a bottom elevation view of the plate of Fig. 7;

[0037] Fig. 10 is a plan view of one locking splice plate laid flat (e.g., prior to curving);

[0038] Fig. 11 is a side elevation view of the plate of Fig. 10;

[0039] Fig. 12 is a bottom elevation view of the plate of Fig. 10;

[0040] Fig. 13 is a plan view of another locking splice plate laid flat (e.g., prior to curving);

[0041] Fig. 14 is a side elevation view of the plate of Fig. 13;

[0042] Fig. 15 is a bottom elevation view of the plate of Fig. 13;

[0043] Fig. 16 is a partial side elevation view of an edge portion of the plate of Fig. 4 showing a threaded stud extending from the plate;

[0044] Fig. 17 is a partial side elevation view of a pair of adjacent plates according to Fig. 3 secured together with a locking plate according to any of Figs. 7, 10 or 13;

[0045] Fig. 18 is a plan view of a liner plate system (with line plates shown flat rather than curved);

[0046] Fig. 19 is a partial side elevation of an embodiment demonstrating bolted interconnection of plates;

[0047] Fig. 20 is a plan view of another embodiment of T-shaped locking plate laid flat (e.g., prior to curving);

[0048] Fig. 21 is a side elevation view of the plate of Fig. 20;

[0049] Fig. 22 is a plan view of one locking intermediate plate laid flat (e.g., prior to curving);

[0050] Fig. 23 is a side elevation view of the plate of Fig. 22;

[0051] Fig. 24 is a plan view of another locking intermediate plate laid flat (e.g., prior to curving);

[0052] Fig. 25 is a side elevation view of the plate of Fig. 24;

[0053] Fig. 26 shows a partially constructed liner plate system (shown flat rather than curved); and

[0054] Fig. 27 shows an enlarged view of a seal joint.

DETAILED DESCRIPTION

[0055] Referring to Figs. 1 and 2, an exemplary liner plate system 10 is shown and includes a plurality of arcuate liner plate units 12 and a plurality of liner lock plates 14 including multiple T-shaped lock plates 14A, multiple intermediate plates 14B arranged laterally and multiple intermediate plates 14C arranged vertically. The T-shaped lock plates 14A are spaced apart from each other and located locations where three arcuate liner plates come together. The intermediate plates 14B and 14C overlap with and interconnect the T-shaped lock plates, thereby functioning as splice plates, and the plates 14A, 14B and 14C are secured to the arcuate liner plate units such that the cylindrical wall structure 100 formed by the combination of the liner lock plates 14A, 14B and 14C and the arcuate line plate units 12 is a rigid, unitary structure. A portion of a pre-existing concrete wall structure 200 (e.g., forming a vertical mine shaft) is shown. The liner plate system 10 may be used to rehabilitate such a concrete wall structure 200 as described in more detail below.

[0056] As shown in Figs. 3-6, each arcuate liner plate unit 12 includes a radially outer side 16 and a radially inner side 18. The radially inner side 18 includes a peripherally

extending seal recess 20 (shown in shadow in Fig. 4) extending along all four edges and having a seal material 22 thereon. Prior to interconnection of the various plates to form the liner system, the seal material has a radial thickness R_T greater than a radial depth R_D of the seal recess so as to protrude beyond (e.g., between 60 and 80 thousandths beyond) a primary inner surface of the radially inner side as shown in Fig. 6. Each arcuate liner plate unit 12 also includes a plurality of threaded mount studs 24 extending inwardly from the radially inner side. The studs 24 are spaced apart and located alongside the perimeter seal recess 20. By way of example, the arcuate plate 12 may be formed from a steel plate (e.g., 1/4" to 1" thick) that is worked/rolled into the arcuate form. The studs 24 may be welded to the plate or, alternatively, may be threaded into threaded holes that are placed in the plate. The peripheral seal recess 20 may be a mitered recess (e.g., 1/16" to 5/16" depth). In one example, each arcuate plate may span between 45 and 120 circumferential degrees (e.g., 60 to 90 degrees).

[0057] As shown in Figs. 7-9, each T-shaped lock plate 14A (shown in a flat configuration in these views) includes ends 30A, 30B and 30C, with end 30A located on the central leg of the T and with ends 30B and 30C at opposite ends of the cross-leg of the T. The plate has a radially inner side 32 and a radially outer side 34. The radially outer side 34 includes a seal recess 36 formed therein. The seal recess has a seal material thereon (e.g., similar to Fig. 6), the seal material having a thickness greater than a depth of the seal recess. Each T-shaped lock plate also includes a plurality of openings 38 on the central leg and slotted openings 40 on the cross-leg. Each end of each T-shaped lock plates includes a respective recessed mating region 42, 44, 46 at its radially inner side. The T-shaped plate may also be formed of steel plate (e.g., 1/8" to 12/16" thick) curved into necessary shape to abut with the liner plates.

[0058] As shown in Figs. 10-12, lateral/circumferential intermediate plates 14B (shown flat in these views) include opposite ends 50 and 52, a radially inner side 54 and a radially outer side 56. The radially outer side 56 includes a seal recess 58 formed therein. The seal recess has a seal material thereon (e.g., similar to Fig. 6), the seal material having a thickness greater than a depth of the seal recess. Each circumferential splice plate 14B also includes a plurality of slotted openings 60. The ends of the plate 14B include recessed mating regions 62 and 64 at the radially outer side. The seal recess and seal material therein runs from the edge of mating recess 62 to the edge of mating recess 64. The plate 14B is curved into an arc (in a direction to bring ends 50 and 52 closer together) to suitably

about the inner side of the arcuate liner plate units.

[0059] Referring to Figs. 13-15, vertical intermediate plates 14C (shown flat in these views) include opposite ends 70 and 72, a radially inner side 74 and a radially outer side 76. The radially outer side 76 includes a seal recess 78 formed therein. The seal recess has a seal material thereon (e.g., similar to Fig. 6), the seal material having a thickness greater than a depth of the seal recess. Each circumferential splice plate also includes a plurality of openings 80. The ends of the plate include recessed mating regions 82 and 84 at the radially outer side. The seal recess and seal material therein runs from the edge of mating recess 82 to the edge of mating recess 84. The plate 14C is curved into an arc (that runs consistent with the arc-shape 77 shown in dashed line form in fig. 14) to suitably about the inner side of the liner plates.

[0060] Fig. 16 shows an exemplary bolt stud 24 connection to the radially inner side of liner plates, where the bolt is welded to the plate. However, as noted above, threaded holes could be placed on the inner side of the line plate and a threaded end of the bolt stud threaded therein as an alternative connection. Fig. 17 shows an exemplary connection of the plates, with a liner lock plate (e.g, any of 14A, 14B or 14C) bridging an edge joint 90 between two arcuate liner plates 12' and 12'', where it is seen that the peripheral seal recesses at the radially inner sides of the two liner plates abut each other and the seal recess at the radially outer side of the lock plate aligns with and overlays the liner plate seal recesses. The bolt studs 24 align with and extend through the openings in the lock plates and nuts 94 (with or without washers) are used to secure the lock plate to the liner plates 12' and 12'' in the bridging manner so that a fixed, rigid connection of the liner plates 12 is made and the seal material in the aligned recesses is compressed together for sealing purposes.

[0061] Fig. 18 shows an arrangement of liner plates 12 and lock plates 14A, 14B and 14C with the lock plates securing liner plates together along both vertical edge joints and horizontal, circumferential edge joints. Notably, in the illustrated embodiment the recessed mating regions of the lock plates are overlapped so that the lock plates form a continuous rigid framework of connection. Also, the openings 40 and 60 (Figs. 7 and Fig. 12) are slotted to provide suitable clearance for bolt stud passage given the circumferential configuration of the liner plates and the radial direction of the bolt studs.

[0062] In one example, the seal material may be formed by a polymeric seal that is applied via a plural component material processing technique. As used herein, the term

plural component processing technique means blending two or more chemicals together in a specific or varying ratio with either direct impingement equipment, equipment utilizing a static mixer assembly to mix/blend the chemicals or by mixing in an open container by hand or by other mechanical mixing method to produce material that cures to some degree. Prior to applying the seal material, the seal recesses may be prepared by use of an abrasive blast process that forms a 3 mil minimum surface profile on the bottom and sides of the recess, which assures good bonding or adhesion of the seal member within the recess. Where the seal material is applied so as to protrude from the top of the recess, a planing type device may be used to trim the seal member down to a specified, desired height. However, other techniques could also be used to achieve the final height of the seal member. Moreover, other seal materials could be used as well. A chemical weld activator coating may be applied to surfaces of abutting seal members so that when the two seal members engage each other they become welded together, further enhancing the seal effect. By way of example, the polymeric seal material may be a plural component impingement mix polyurea product and the chemical weld activator may be a single component, brush applied material that will chemically bond thermoset polyurethane/polyurea material systems.

[0063] In one embodiment, a bonded monolithic polymer seal (BMPS) material may be used, made up of a plural component system consisting of an "isocyanate" (also known as a diisocyanate with other variations that may include: isophorone diisocyanate, methylene diphenyl diisocyanate, toluene diisocyanate or hexamethylene diisocyanate) and mixed with one or more of the following: an alcohol, an hydroxyl, a polyol, or an amine, creating a "polyurethane or polyurea" compound. An example of this material is Custom Linings 911 pure polyurea, available from Custom Linings, Inc. of Beuna Vista, Colorado, but there are products that may be used.

[0064] Thus, the described system provides a low profile liner system (e.g., full radial depth from radially inner end of the bolt studs 24 to the radially outer side of the liner plates being less than 4 inches, such as between two and three inches). The liner system enables a method of rehabilitating a vertical mine shaft bounded by a concrete wall structure. The method involves (1) removing an interior portion of the concrete wall structure; (2) installing a liner plate system including: (a) utilizing a plurality of arcuate liner plate units, each arcuate liner plate unit including a radially outer side and a radially inner side, the radially inner side including a peripherally extending seal recess having a

seal material thereon, the seal material having a radial thickness greater than a radial depth of the seal recess, each arcuate liner plate unit further including a plurality of threaded mount studs extending inwardly from the radially inner side; (b) utilizing a plurality of liner lock plates, each lock plate having an inner side and an outer side, the outer side including a seal recess formed therein, the seal recess having a seal material thereon, the seal material having a thickness greater than a depth of the seal recess, each lock plate further including a plurality of openings therein; and (3) arranging the arcuate liner plates and the liner lock plates to form a cylindrical wall structure, with a first set of arcuate liner plates forming a first ring and a second set of arcuate liner plates forming a second ring, the first ring having a top edge, bottom edge and multiple vertical edge joints, the second ring having a top edge, bottom edge and multiple vertical edge joints, the top edge of the first ring abutting a bottom edge of the second ring, the vertical edge joints of the first ring circumferentially offset from the vertical edge joints of the second ring, multiple liner lock plates positioned along the inner side of the first and second ring with the seal material of the liner lock plates in contact with the seal material of the arcuate liner plates, the threaded mount studs of the arcuate liner plates extending through openings of the liner lock plates, nuts on the mount studs holding the liner lock plates adjacent the arcuate liner plates.

[0065] As previously indicated, the threaded mount studs may either be welded to the radially inner side of the liner plate or threadedly inserted into threaded openings at the radially inner side of the liner plate, with nuts used for securing the plates together. In another embodiment, represented by Fig. 19, the arcuate liner plates 12 include drilled and tapped holes 102 that receive bolts 104 (with or without associated washers) to secure the plates together and compress the abutting seals.

[0066] The liner lock plates may include multiple T-shaped lock plates 14A, where the ends of each T-shaped lock plate are spaced apart from the ends of other T-shaped lock plates when the T-shaped lock plates are joined to the arcuate liner plates. The liner lock plates further include multiple intermediate splice plates interconnecting the T-shaped lock plates, the splice plates including vertically oriented splice plates 14C and laterally oriented splice plates 14B.

[0067] In the above-described illustrated embodiment, each end of each T-shaped lock plates may include a recessed mating region at its radially inner side, and each end of each intermediate plate may include a recessed mating region at its radially outer side. The recessed mating regions of the T-shaped lock plates overlap the recessed mating regions of

the intermediate plates. In an alternative embodiment, the recessed mating regions, and resulting overlap of the lock plates, may be absent.

[0068] In this regard, Figs. 20-21 illustrate (in flat layout) a T-shaped locking plate 114A without recessed regions. The plate has a radially inner side 132 and a radially outer side 134. The radially outer side 134 includes a seal recess 136 formed therein. The seal recess has a seal material thereon (e.g., similar to Fig. 6), the seal material having a thickness greater than a depth of the seal recess. Each T-shaped lock plate also includes a plurality of openings 138 on the central leg and slotted openings 140 on the cross-leg. Figs. 22-23 illustrate (in flat layout) an intermediate locking plate 114B without recessed regions. The plate 114B includes opposite ends 150 and 152, a radially inner side 154 and a radially outer side 156. The radially outer side 156 includes a seal recess 158 formed therein. The seal recess has a seal material thereon (e.g., similar to Fig. 6), the seal material having a thickness greater than a depth of the seal recess. Each plate 114B also includes a plurality of slotted openings 160. Figs. 24-25 illustrate (in flat layout) an intermediate locking plate 114C without recessed regions. Each plate 114C includes opposite ends 170 and 172, a radially inner side 174 and a radially outer side 176. The radially outer side 176 includes a seal recess 178 formed therein. The seal recess has a seal material thereon (e.g., similar to Fig. 6), the seal material having a thickness greater than a depth of the seal recess. Each plate 114C also includes a plurality of openings 180. The plates 114A, 114B and 114C are curved in a manner similar to plates 14A, 14B and 14C as described above.

[0069] In both embodiments, the seal recess of each T-shaped lock plate extends to each end thereof. In the embodiment of Figs. 7-15, the seal recess of each intermediate plate (14B or 14C) extends from one recessed mating region of the intermediate plate to the other recessed mating region of the intermediate plate. In the embodiment of Figs. 20-25, the seal recess of each intermediate plate (114B or 114C) extends from end to end of the intermediate plate. In either case, upon assembly, the ends of the T-shaped lock plate seal recesses are positioned proximate to or in abutment with the ends of the intermediate plate seal recesses.

[0070] Referring to Fig. 26, partial build of a liner system is shown using liner lock plates 114A, 114B and 114C. The liner lock plates are secured to curved liner plate units 12A, 12B, 12C, 12D and 12E. The curved liner plate units and the liner lock plates are arranged to form a curved wall structure. The curved liner plates forming multiple rings

(e.g., 210A and 210B), each ring having opposite end edges 212 and 214, and multiple interior edge joints 216. The rings are arranged end to end such that abutting end edges form multiple end edge joints (e.g., 218). As shown, the interior edge joints 216 of each ring are circumferentially offset from the interior edge joints of each adjacent ring. The liner lock plates 114A, 114B and 114 C are secured along an inner side of the wall structure with the seal material of the liner lock plates pressed into contact with the seal material of the curved liner plate units in order to seal both the end edge joints 218 between adjacent rings and the interior edge joints 216 of each ring. Each T-shaped lock plate 114A covers a portion of one of the interior edge joints 216 and a portion of one of the end edge joints 219. Multiple seal joints 230 are formed between ends of the T-shaped lock plates 114A and adjacent ends of the intermediate plates 114B or 114C, and at each seal joint seal material of the T-shaped lock plate and seal material of the intermediate plate is compressed to create an abutting and sealing contact therebetween that is sufficient to fill and close off any gap 231 between the ends of the plates 114A and 114B or 114C, as best seen in Fig. 27, where abutting seal material, which may become welded if a weld activator is used, is shown at 232.

[0071] Regardless of the embodiment of the liner system, once the liner system is assembled/installed, a backgrouting operation at the radially outer side of the liner system (e.g., into the space 190 (see Fig. 1) between the concrete wall structure 200 and the liner system) may be performed to provide continuity between the liner system and the existing wall structure. In one example, the backgrouting operation may be performed from the top or bottom edge of a set of rings. In another example, the liner plates may include openings through which the grout may be delivered, with the openings later sealed by plugs.

[0072] While particular embodiments have been illustrated and described, it is to be clearly understood that the above description is intended by way of illustration and example only and is not intended to be taken by way of limitation, and that changes and modifications are possible.

[0073] What is claimed is:

Claims

1. A method of rehabilitating a vertical mine shaft bounded by a concrete wall structure, the method comprising:
 - removing an interior portion of the concrete wall structure;
 - installing a liner plate system adjacent the concrete wall structure including:
 - utilizing a plurality of arcuate liner plate units, each arcuate liner plate unit including a radially outer side and a radially inner side, the radially inner side including a peripherally extending seal recess having a seal material thereon, the seal material having an uncompressed radial thickness greater than a radial depth of the seal recess so as to protrude beyond a primary inner surface of the radially inner side;
 - utilizing a plurality of liner lock plates, each lock plate having an inner side and an outer side, the outer side including a seal recess formed therein, the seal recess having a seal material thereon, the seal material having an uncompressed thickness greater than a depth of the seal recess so as to protrude beyond a primary outer surface of the outer side;
 - arranging the arcuate liner plate units and the liner lock plates to form a cylindrical wall structure, with a first set of arcuate liner plate units forming a first ring and a second set of arcuate liner plate units forming a second ring, the first ring having a top edge, bottom edge and multiple vertical edge joints, the second ring having a top edge, bottom edge and multiple vertical edge joints, the top edge of the first ring abutting a bottom edge of the second ring to form a lateral edge joint, the vertical edge joints of the first ring circumferentially offset from the vertical edge joints of the second ring, the liner lock plates positioned along an inner side of the cylindrical wall structure with the seal material of the liner lock plates in contact with the seal material of the arcuate liner plate units; and
 - utilizing threaded members to hold the liner lock plates adjacent the arcuate liner plate units such that the cylindrical wall structure formed by the combination of the liner lock plates and the arcuate liner plate units is a rigid, unitary structure.
2. The method of claim 1 wherein each lock plate includes a plurality of openings therein, the threaded members are either mount studs welded to the radially inner side of the arcuate liner plate unit or bolts threadedly inserted into threaded openings at the radially

inner side of the arcuate liner plate unit, in either case each threaded member passes through a respective one of the lock plate openings.

3. The method of claim 1 wherein the liner lock plates include multiple T-shaped lock plates, where the ends of the T-shape are spaced apart from each other when the T-shaped lock plates are joined to the arcuate liner plate units.

4. The method of claim 3 wherein the liner lock plates include multiple splice plates interconnecting the T-shaped lock plates, the splice plates including vertically oriented splice plates and laterally oriented splice plates.

5. The method of claim 4 wherein:
each end of each T-shaped lock plate includes a recessed mating region at its radially inner side,
each end of each splice plate includes a recessed mating region at its radially outer side,
and the recessed mating regions of the T-shaped lock plates overlap the recessed mating regions of the splice plates.

6. The method of claim 5 wherein:
the seal recess of each T-shaped lock plate extends to each end thereof;
the seal recess of each splice plate extends from one recessed mating region of the splice plate to the other recessed mating region of the splice plate,
the ends of the T-shaped lock plate seal recesses are adjacent the ends of the splice plate seal recesses.

7. The method of claim 3 wherein:
the liner lock plates include multiple intermediate plates connected between spaced apart T-shaped lock plates, the intermediate plates including vertically oriented intermediate plates and laterally oriented intermediate plates, each end of each T-shaped lock plate is positioned proximate to or in abutment with an end of an adjacent intermediate plate without any overlap between the T-shaped lock plates and the intermediate plates.

8. The method of claim 3 wherein each T-shaped lock plate covers a portion of one of the vertical edge joints and a portion of the lateral edge joint.
9. The method of claim 1 including the further step of applying a chemical weld activator coating to seal members of the arcuate liner plate units and/or seal members of the locking plates so that when two seal members engage each other they become welded together.
10. The method of claim 1, further including performing a backgrouting operation at the radially outer side of the liner plate system to provide continuity between the liner plate system and the concrete wall structure.
11. A liner plate system for lining shafts or tunnels, the system comprising:
a plurality of curved liner plate units, each curved liner plate unit including a radially outer side and a radially inner side, the radially inner side including a peripherally extending seal recess having a seal material thereon;
a plurality of liner lock plates, each liner lock plate having an inner side and an outer side, the outer side including a seal recess formed therein, the seal recess having a seal material thereon;
the curved liner plate units and the liner lock plates arranged to form a curved wall structure, wherein with the curved liner plates forming multiple rings, each ring having a first end edge, a second end edge and multiple interior edge joints, the rings arranged end to end such that abutting end edges form multiple end edge joints, wherein the interior edge joints of each ring are circumferentially offset from the interior edge joints of each adjacent ring, wherein the liner lock plates are secured along an inner side of the curved wall structure with the seal material of the liner lock plates pressed into contact with the seal material of the curved liner plate units in order to seal both the end edge joints between adjacent rings and the interior edge joints of each ring.
12. The system of claim 11, wherein a plurality of threaded members secure the liner lock plates to the curved liner plate units, wherein each liner lock plate includes a plurality of openings therein and through which a respective one of the threaded members extends.

13. The system of claim 12 wherein the threaded members are formed by threaded mount studs extending inwardly from the radially inner sides of the curved liner plate units and nuts on the mount studs hold the liner lock plates adjacent the curved liner plate units and compress the seal material therebetween.

14. The system of claim 12 wherein each of the curved liner plate units includes a plurality of threaded holes and the threaded members are formed by bolts, each bolt extending through a respective one of the liner lock plate openings and into a respective one of the threaded holes to hold the liner lock plates adjacent the curved liner plate units and compress the seal material therebetween.

15. The system of claim 12 wherein the seal material of the curved liner plate units is chemically welded to the seal material of the liner lock plates.

16. The system of claim 11 wherein the seal recess of each liner lock plate aligns with side by side seal recesses of the curved liner plate units such that the seal material of the seal recess of each liner lock plate is pressed into contact with seal material of at least two curved liner plate units.

17. The system of claim 11 wherein the liner lock plates include multiple T-shaped lock plates, where ends of the T-shape are spaced apart from each other when the T-shaped lock plates are joined to the curved liner plate units.

18. The system of claim 17 wherein:
the liner lock plates include multiple splice plates interconnecting the T-shaped lock plates,
each end of each T-shaped lock plate includes a recessed mating region at its radially inner side,
each end of each splice plate includes a recessed mating region at its radially outer side,
and the recessed mating regions of the T-shaped lock plates overlap the recessed mating regions of the splice plates.

19. The system of claim 17 wherein:
the liner lock plates include multiple intermediate plates connected between spaced apart T-shaped lock plates,
each end of each T-shaped lock plate is positioned proximate to or in abutment with an end of an adjacent intermediate plate without any overlap between the T-shaped lock plates and the intermediate plates.
20. The system of claim 19 wherein multiple seal joints are formed between ends of the T-shaped lock plates and adjacent ends of the intermediate plates, at each seal joint seal material of the T-shaped lock plate and seal material of the intermediate plate is compressed to create an abutting and sealing contact therebetween.
21. The system of claim 17 wherein each T-shaped lock plate covers a portion of one of the interior edge joints and a portion of one of the end edge joints.

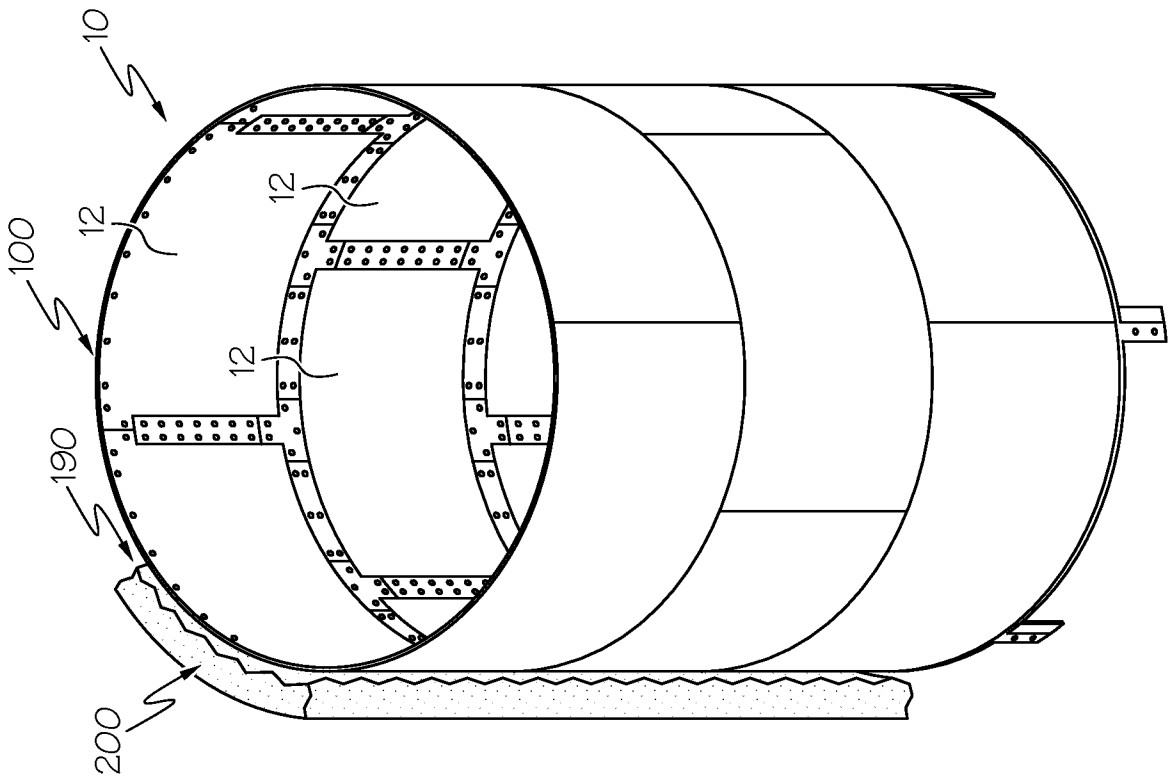

FIG. 1

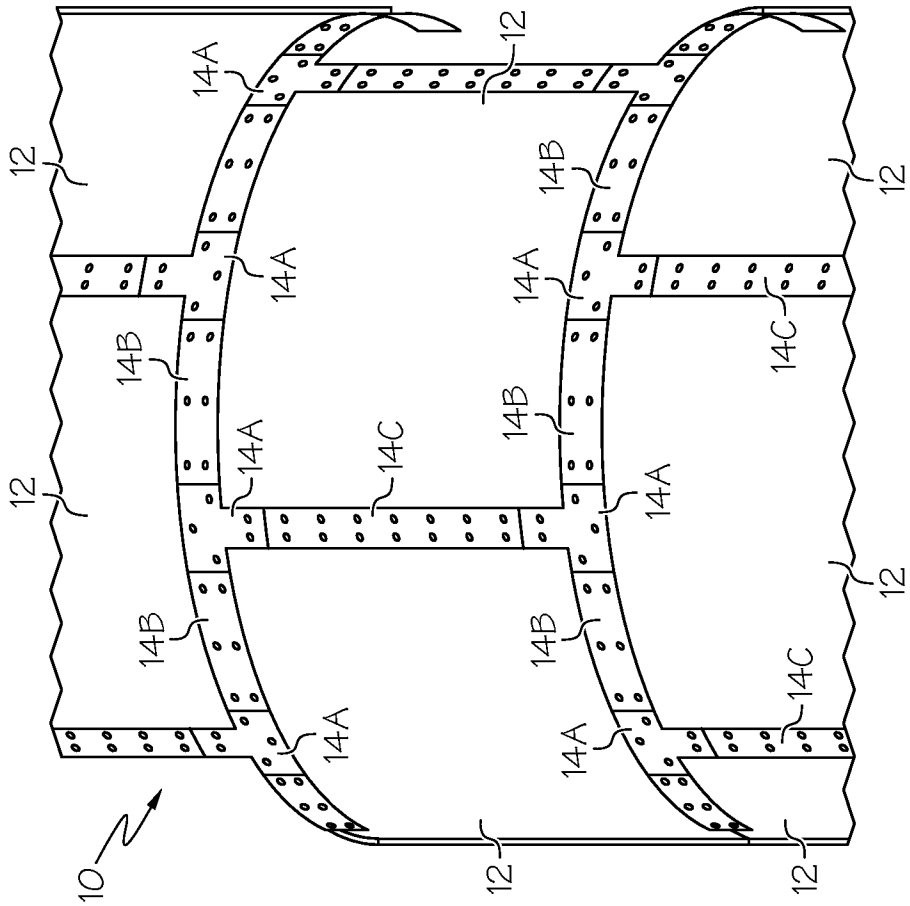

FIG. 2

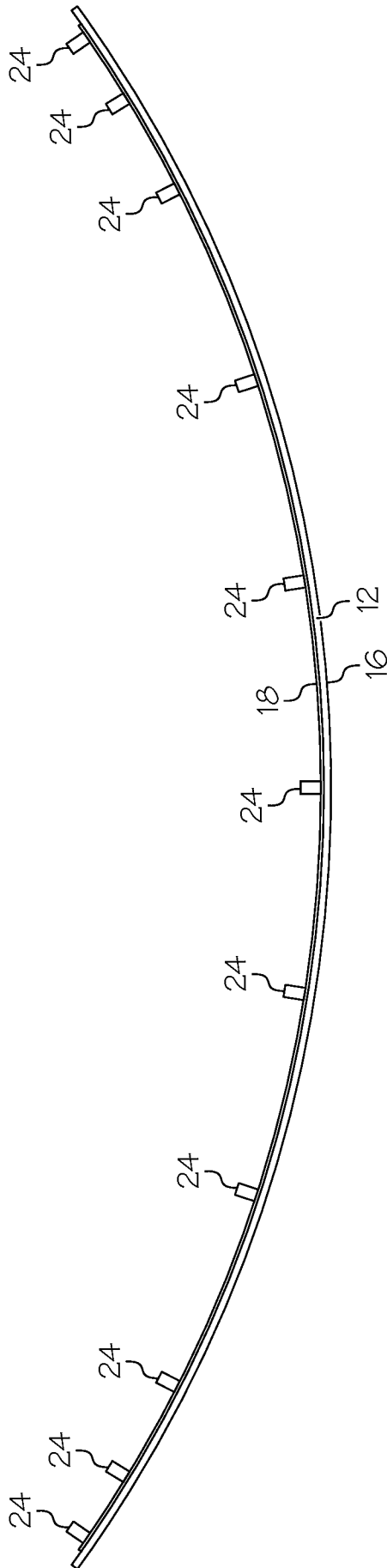

FIG. 3

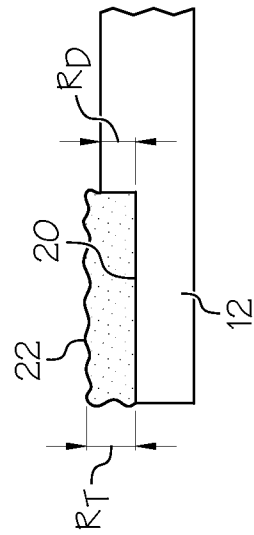

FIG. 6

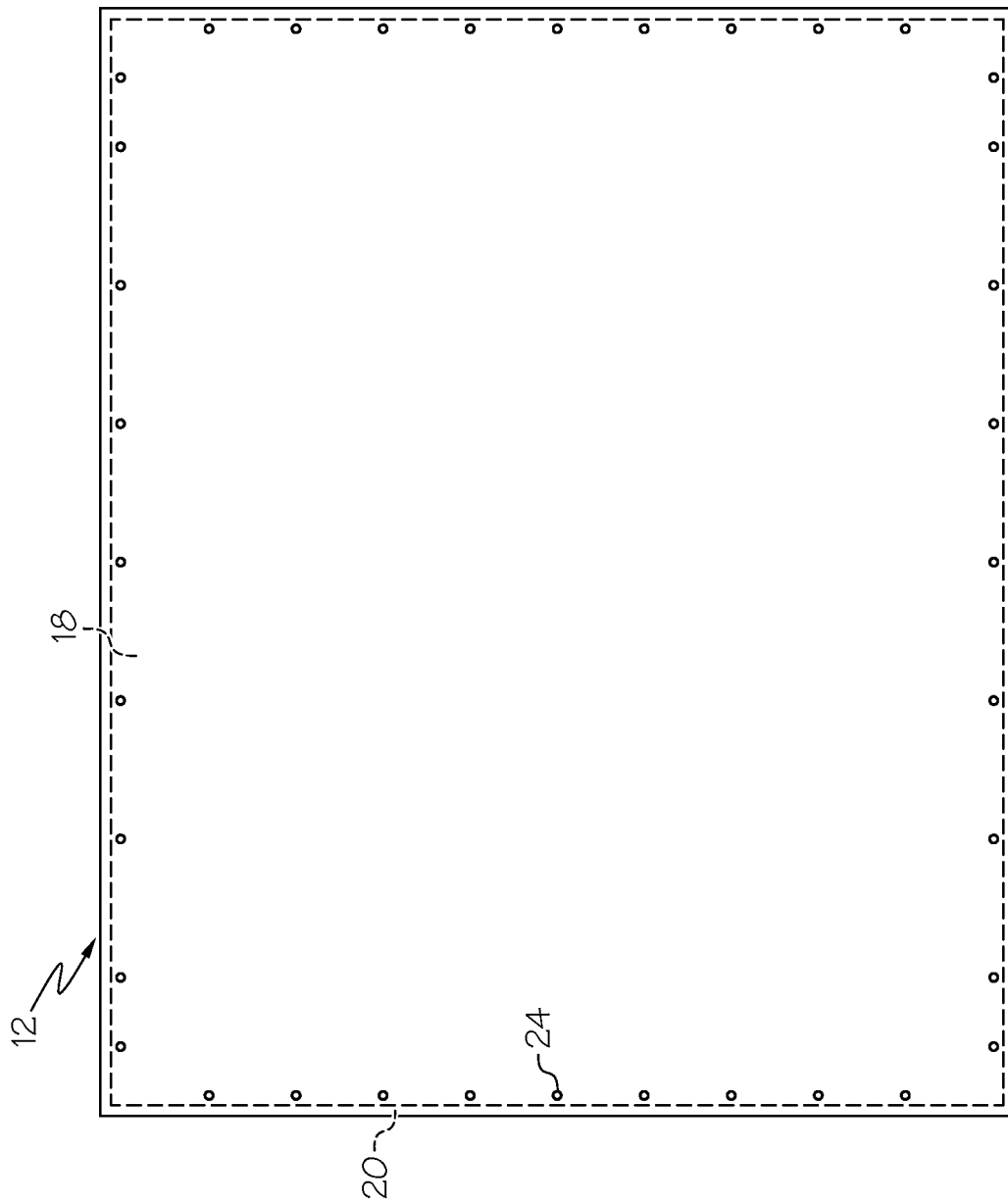

FIG. 4

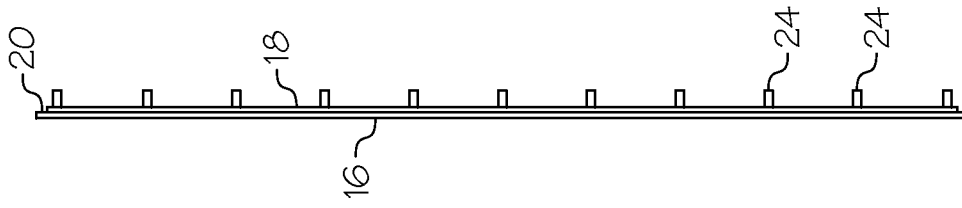

FIG. 5

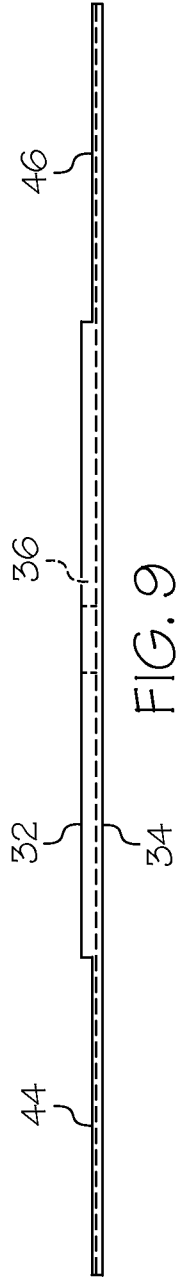
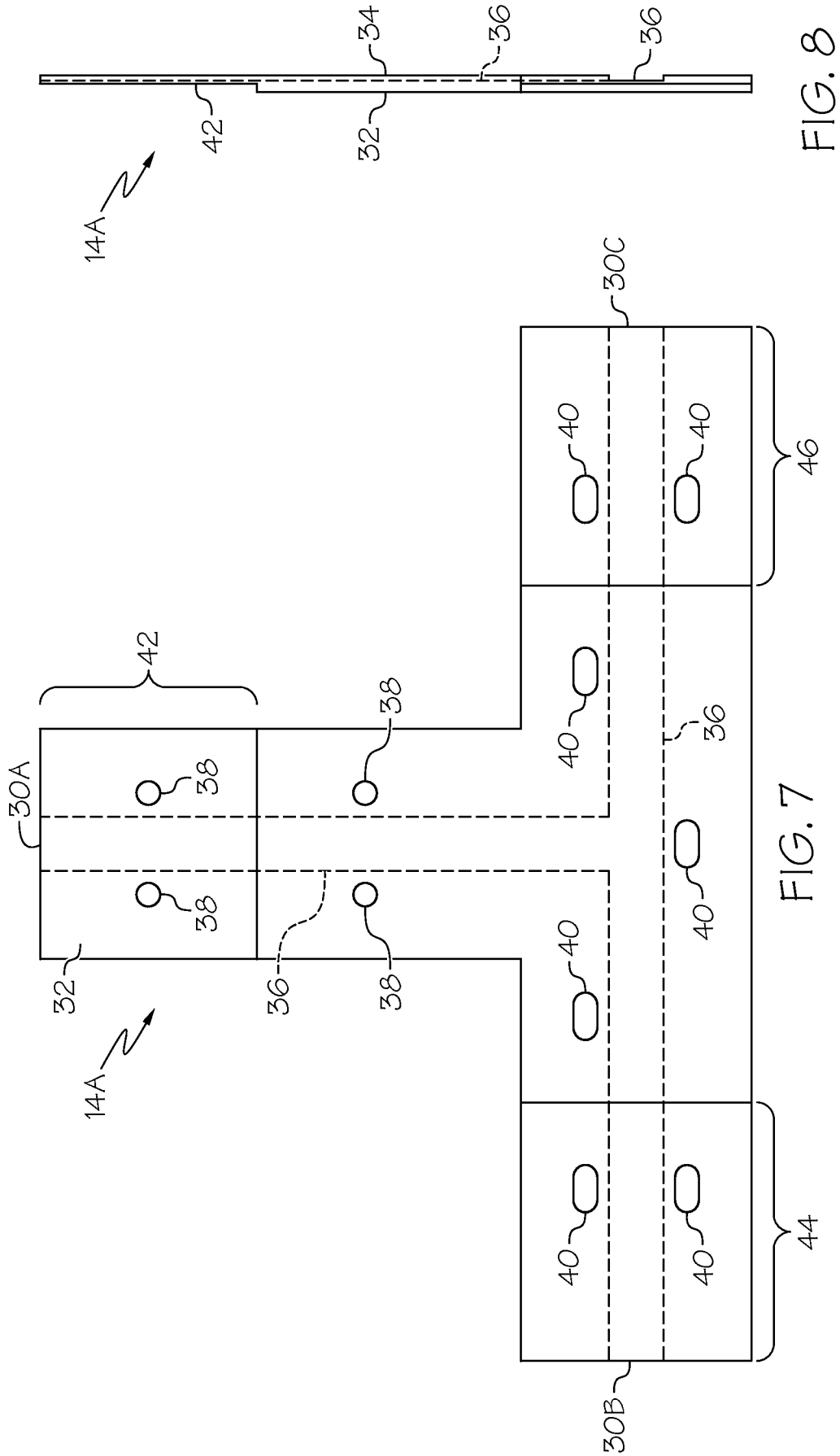

FIG. 8

FIG. 7

FIG. 9

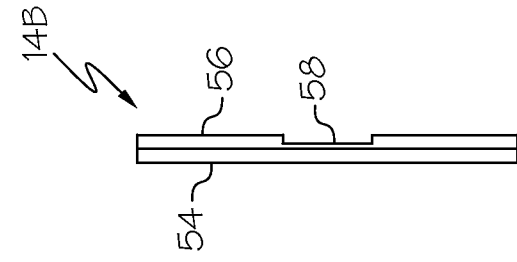

FIG. 11

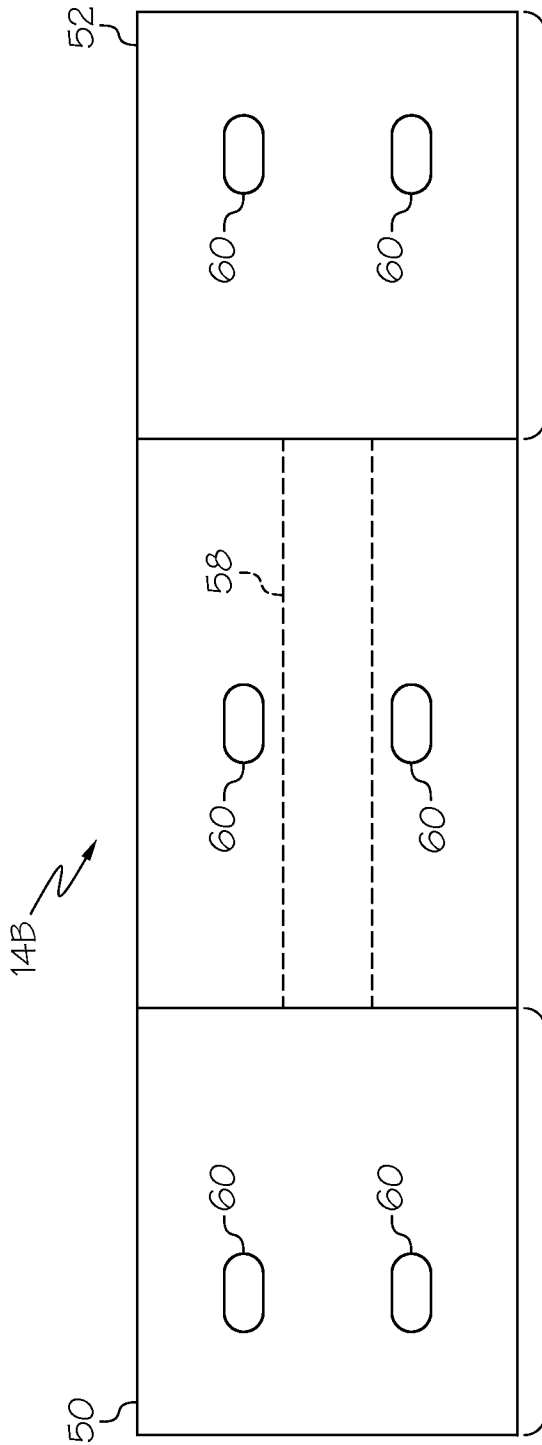

FIG. 10

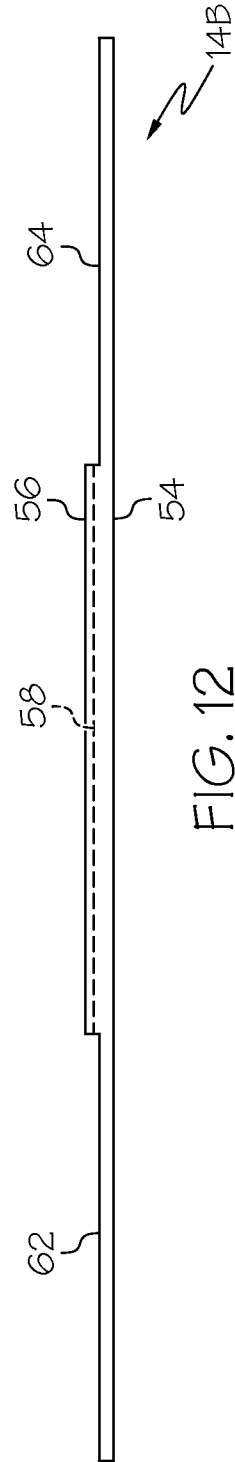

FIG. 12

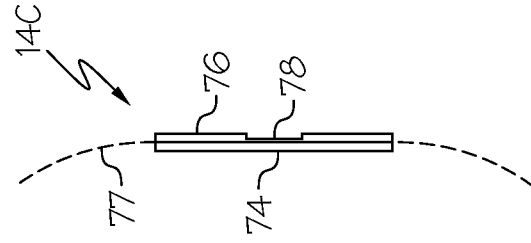

FIG. 14

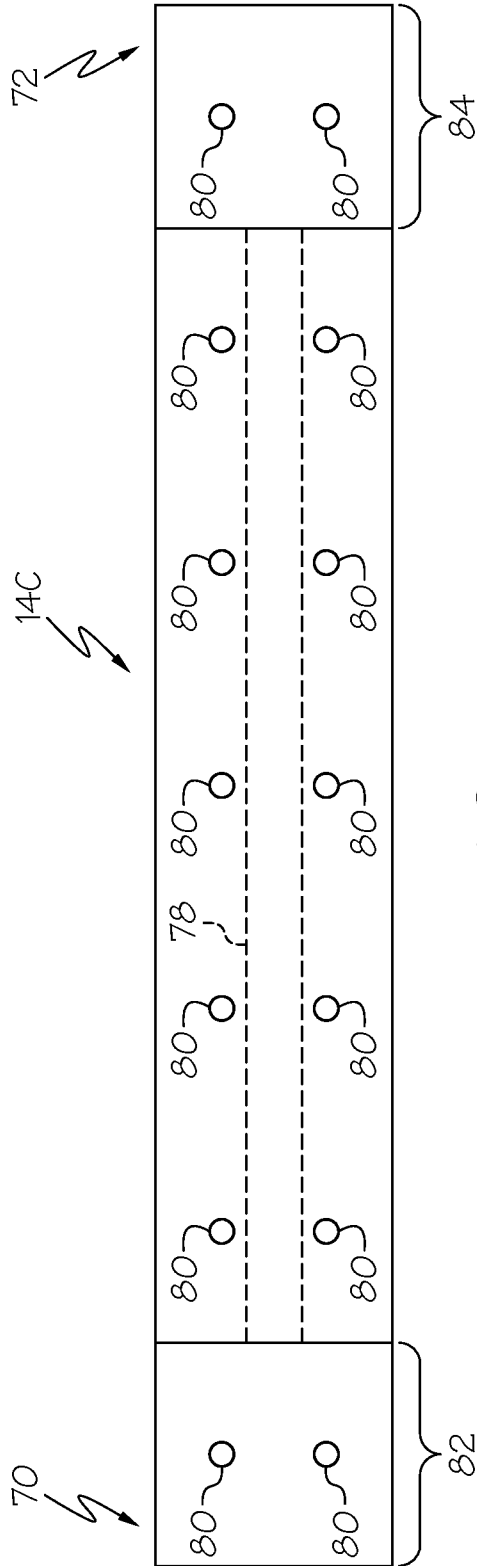

FIG. 13

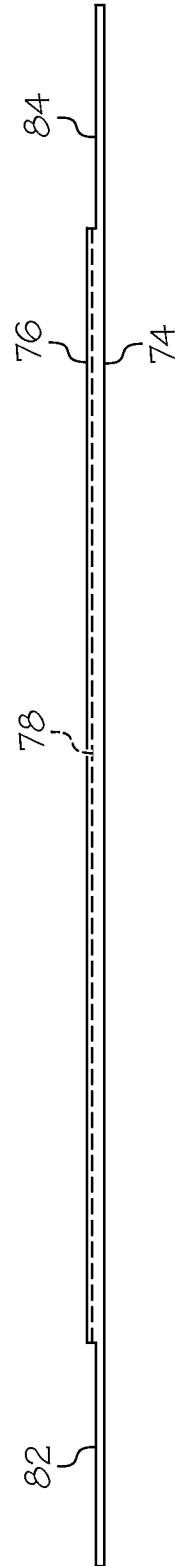

FIG. 15

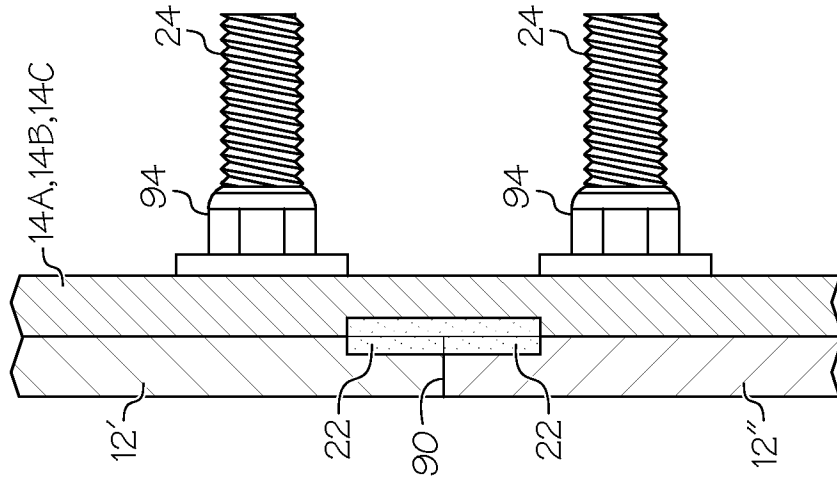

FIG. 17

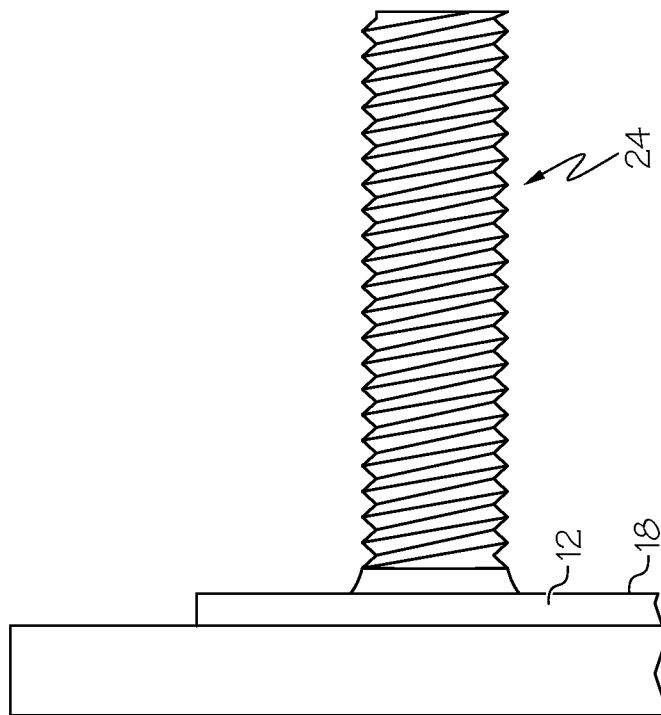

FIG. 16

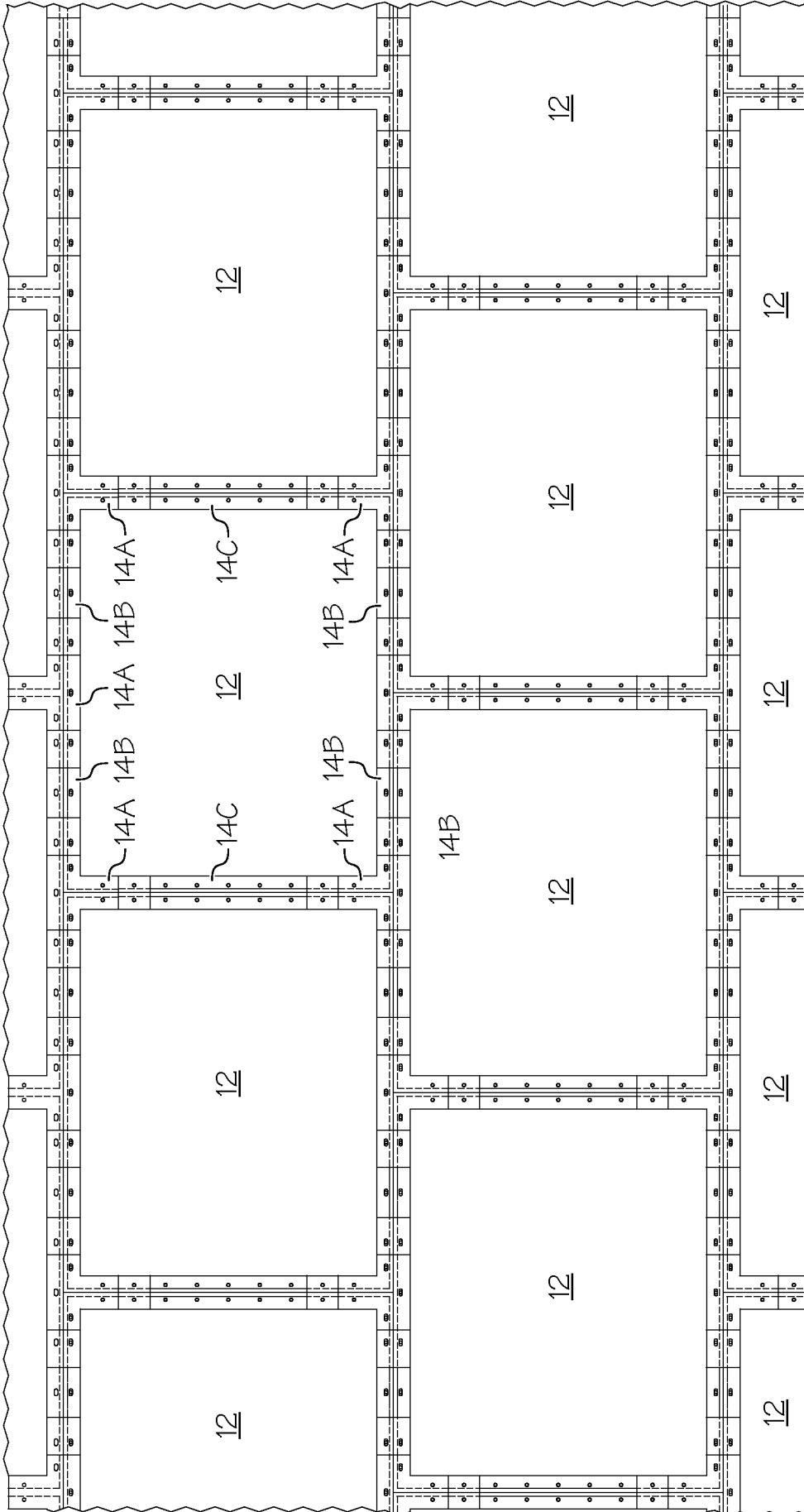

FIG. 18

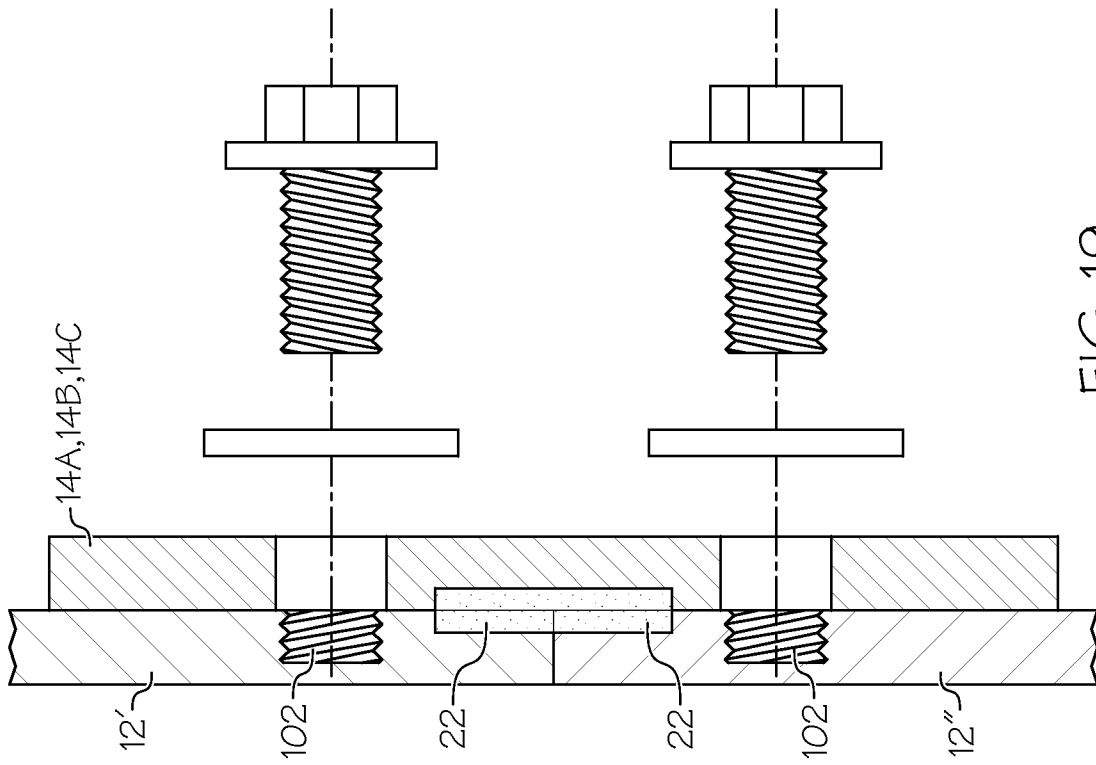

FIG. 19

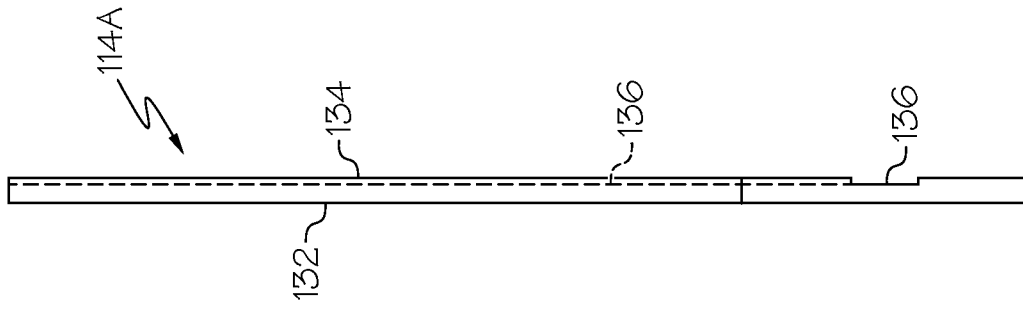

FIG. 21

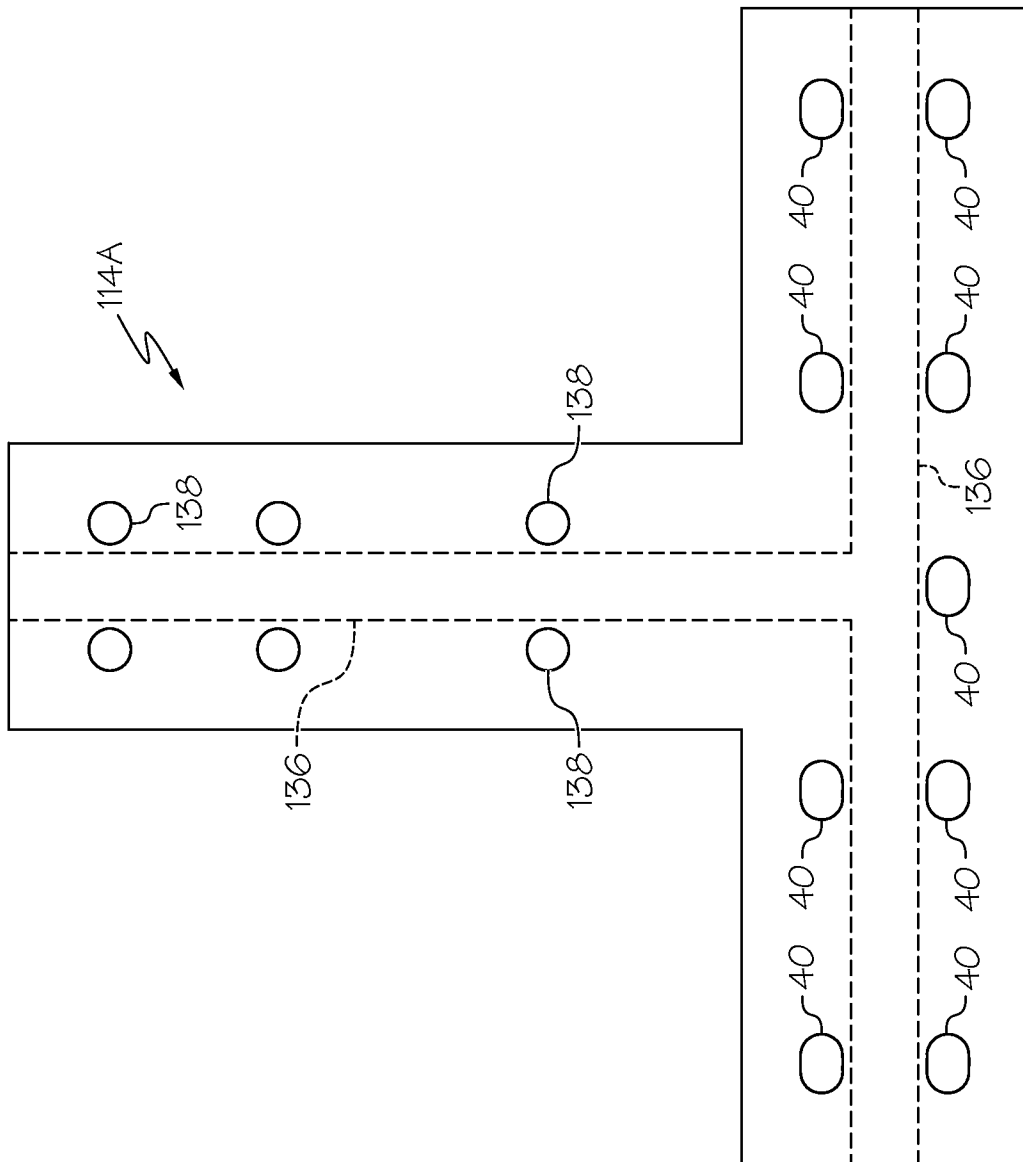

FIG. 20

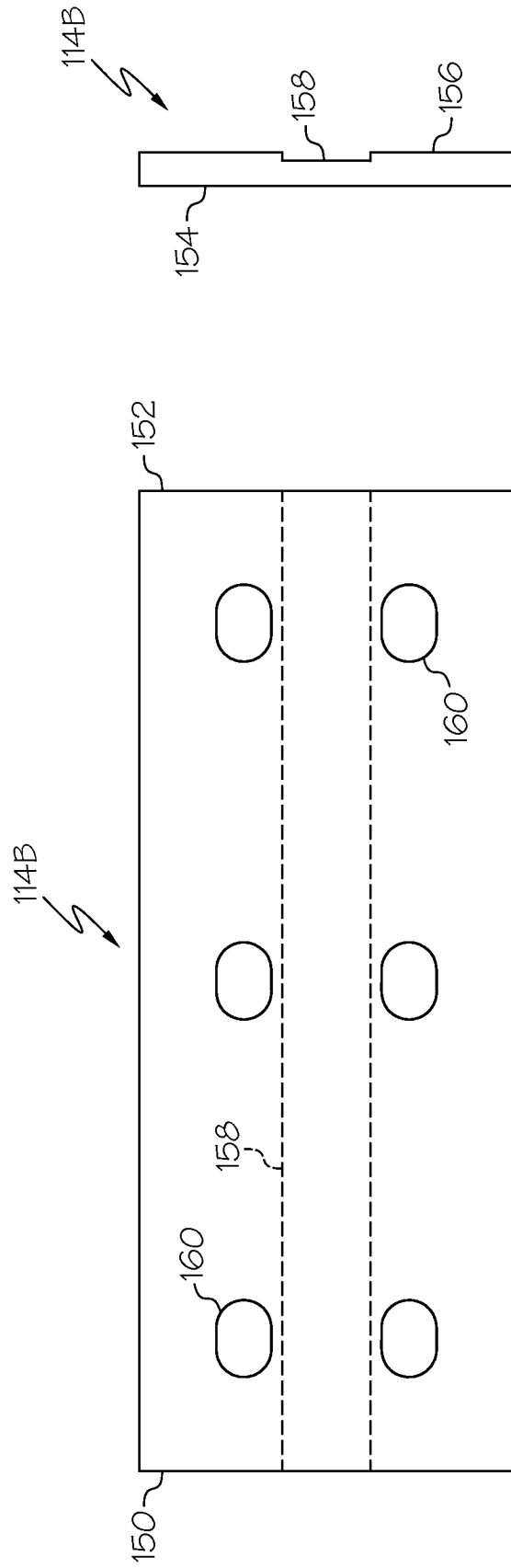

FIG. 23

FIG. 22

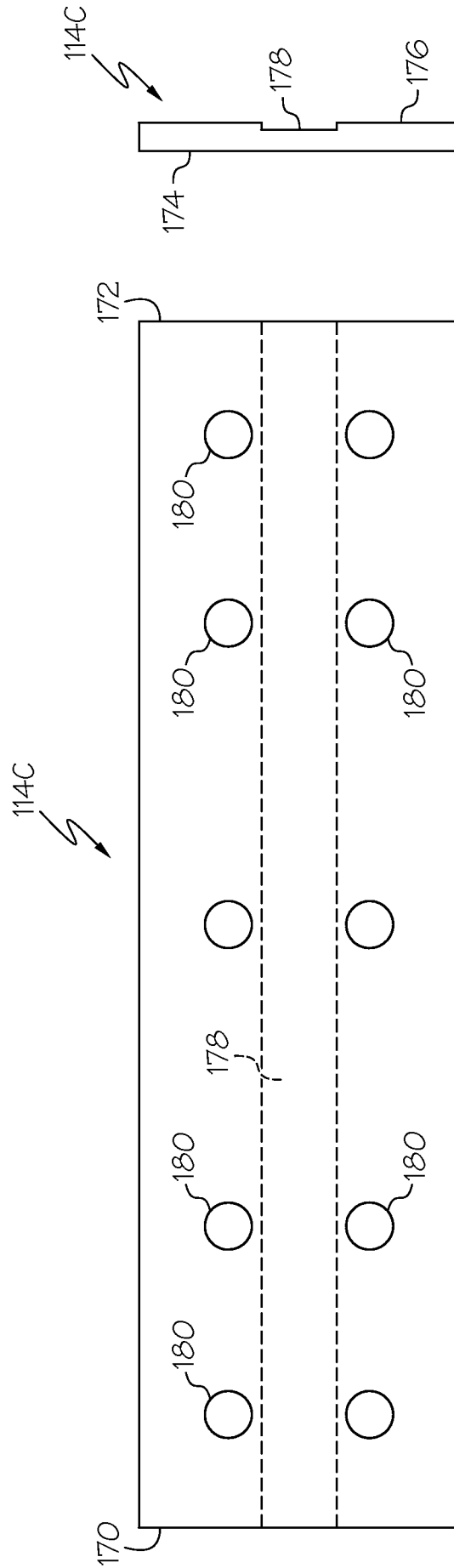

FIG. 25

FIG. 24

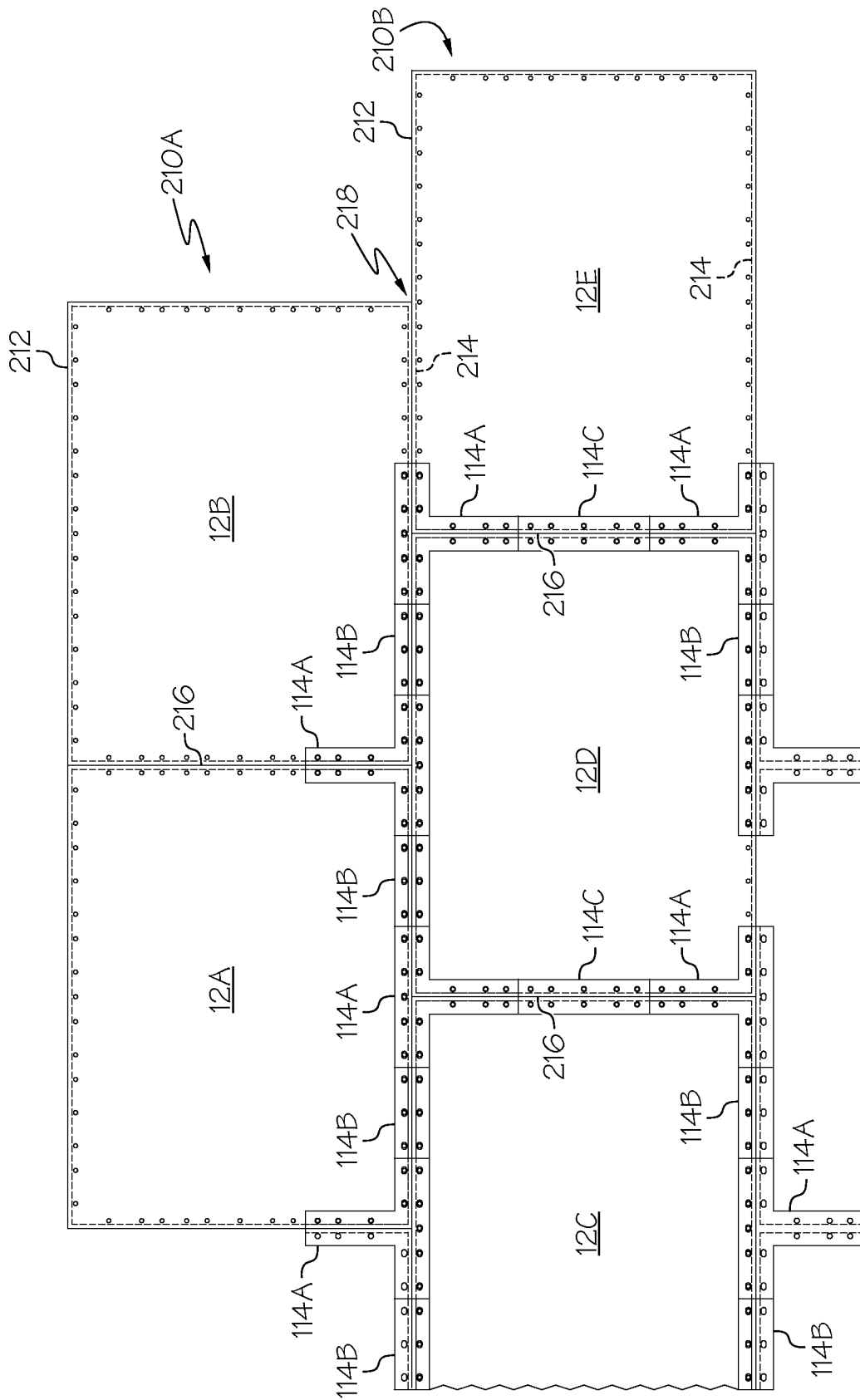

FIG. 26

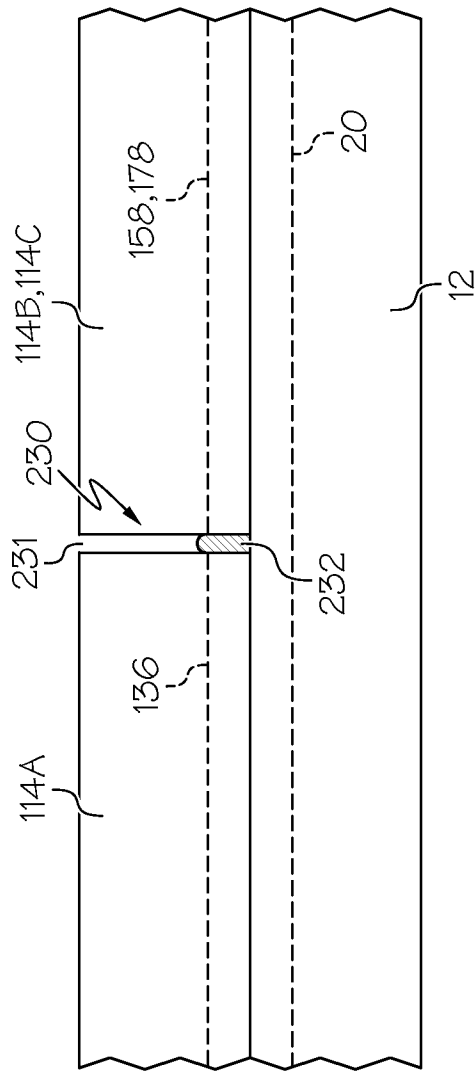

FIG. 27

INTERNATIONAL SEARCH REPORT

International application No.
PCT/US2013/060106

A. CLASSIFICATION OF SUBJECT MATTER
 IPC(8) - E21D 11/15 (2014.01)
 USPC - 405/152
 According to International Patent Classification (IPC) or to both national classification and IPC

B. FIELDS SEARCHED
 Minimum documentation searched (classification system followed by classification symbols)
 IPC(8) - E21D 5/00, 11/00, 11/14, 11/15, 11/38 (2014.01)
 USPC - 405/150.1, 151, 152, 153

Documentation searched other than minimum documentation to the extent that such documents are included in the fields searched
 CPC - E21D 9/00, 11/00, 11/15, 11/38, 11/385 (2013.01)

Electronic data base consulted during the international search (name of data base and, where practicable, search terms used)
 PatBase, Google Patents, Engineering Village, Google, Google Scholar, YouTube.com

C. DOCUMENTS CONSIDERED TO BE RELEVANT

Category*	Citation of document, with indication, where appropriate, of the relevant passages	Relevant to claim No.
A	US 2011/0008108 A1 (CLEVENGER) 13 January 2011 (13.01.2011) entire document	1-21
A	US 5,131,789 A (RATY) 21 July 1992 (21.07.1992) entire document	1-21
A	US 2011/0129300 A1 (DIMILLO) 02 June 2011 (02.06.2011) entire document	1-21
A	US 3,707,846 A (LEBLOND et al) 02 January 1973 (02.01.1973) entire document	1-21
A	US 2011/0188939 A1 (SANDERS) 04 August 2011 (04.08.2011) entire document	1-21

Further documents are listed in the continuation of Box C.

* Special categories of cited documents:

"A" document defining the general state of the art which is not considered to be of particular relevance	"T" later document published after the international filing date or priority date and not in conflict with the application but cited to understand the principle or theory underlying the invention
"E" earlier application or patent but published on or after the international filing date	"X" document of particular relevance; the claimed invention cannot be considered novel or cannot be considered to involve an inventive step when the document is taken alone
"L" document which may throw doubts on priority claim(s) or which is cited to establish the publication date of another citation or other special reason (as specified)	"Y" document of particular relevance; the claimed invention cannot be considered to involve an inventive step when the document is combined with one or more other such documents, such combination being obvious to a person skilled in the art
"O" document referring to an oral disclosure, use, exhibition or other means	"&" document member of the same patent family
"P" document published prior to the international filing date but later than the priority date claimed	

Date of the actual completion of the international search 29 January 2014	Date of mailing of the international search report 19 FEB 2014
--	--

Name and mailing address of the ISA/US Mail Stop PCT, Attn: ISA/US, Commissioner for Patents P.O. Box 1450, Alexandria, Virginia 22313-1450 Facsimile No. 571-273-3201	Authorized officer: Blaine R. Copenheaver PCT Helpdesk: 571-272-4300 PCT OSP: 571-272-7774
---	---