



US00D854592S

(12) **United States Design Patent**
Matsuda

(10) **Patent No.:** **US D854,592 S**

(45) **Date of Patent:** **** Jul. 23, 2019**

(54) **CUTTING TOOL**

(71) Applicant: **SUMITOMO ELECTRIC**
HARDMETAL CORP., Itami-shi (JP)

(72) Inventor: **Naoki Matsuda**, Sorachi-gun (JP)

(73) Assignee: **SUMITOMO ELECTRIC**
HARDMETAL CORP., Itami-shi (JP)

(**) Term: **15 Years**

(21) Appl. No.: **29/603,808**

(22) Filed: **May 12, 2017**

(30) **Foreign Application Priority Data**

Nov. 15, 2016 (JP) 2016-024841
Nov. 15, 2016 (JP) 2016-024842

(51) **LOC (11) Cl.** **15-09**

(52) **U.S. Cl.**
USPC **D15/139**

(58) **Field of Classification Search**
USPC D8/6, 20, 51, 70.1, 98-104, 105-107;
D15/127, 129, 138, 141, 139
CPC Y10T 407/23; Y10T 407/1924; Y10T
407/245; Y10T 408/9098; B23B 27/141;
B23B 27/1614; B23B 2200/049; B23B
2200/323; B23B 2200/3681; B23C
2200/0411; B23C 2200/125; B23C 5/109;
B23C 5/202; B23C 5/207
See application file for complete search history.

(56) **References Cited**

U.S. PATENT DOCUMENTS

D367,866 S * 3/1996 Pantzar D15/139
D744,557 S * 12/2015 Koike D15/139
D772,963 S * 11/2016 Nam D15/139
D795,318 S * 8/2017 Yoshida D15/139
D804,552 S * 12/2017 Lee D15/139
D805,564 S * 12/2017 Lee D15/139

D818,016 S * 5/2018 Yoshida D15/139
D822,080 S * 7/2018 Oh D15/139
D828,414 S * 9/2018 Takahashi D15/139

(Continued)

OTHER PUBLICATIONS

Iscars Helimill. Hardmetal.ie. [Online] [Published Oct. 19, 2015][Accessed Oct. 5, 2018].<URL http://www.hardmetal.ie/iscars-helimill-range-gets-triangular-inserts-with-3-helical-cutting-edges/> (Year: 2015).*

(Continued)

Primary Examiner — Rosemary K Tarcza
Assistant Examiner — Nathaniel D. Buckner
(74) *Attorney, Agent, or Firm* — Baker Botts L.L.P.;
Michael A. Satori

(57) **CLAIM**

The ornamental design for a cutting tool, as shown and described.

DESCRIPTION

FIG. 1 is a front view of a cutting tool showing my new design;
FIG. 2 is a rear view thereof;
FIG. 3 is a top view thereof;
FIG. 4 is a bottom view thereof;
FIG. 5 is a right side view thereof;
FIG. 6 is a left side view thereof;
FIG. 7 is a cross sectional view taken along line 7-7 of FIG. 1;
FIG. 8 is a cross sectional view taken along line 8-8 of FIG. 1;
FIG. 9 is a front perspective view thereof;
FIG. 10 is a rear perspective view thereof; and,
FIG. 11 is a front perspective view thereof, shown in an environment of use.
The broken lines shown in the referential views represent portions that form no part of the claimed design.

1 Claim, 6 Drawing Sheets

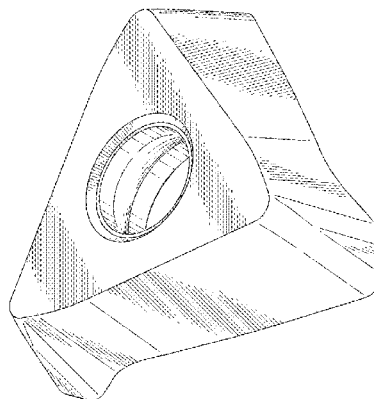
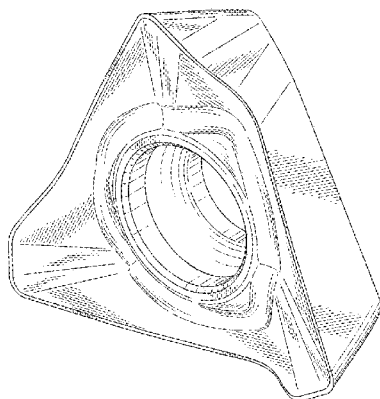

(56)

References Cited

U.S. PATENT DOCUMENTS

2007/0041798 A1* 2/2007 Nasu B23B 27/141
407/114
2009/0290945 A1* 11/2009 Carl B23B 27/1614
407/113
2015/0202697 A1* 7/2015 Shiota B23C 5/109
407/42
2015/0246398 A1* 9/2015 Kawasaki B23B 51/048
408/231

OTHER PUBLICATIONS

Document No. HA29000418, A design of an insert for milling tools on p. 4 of the catalog "Tool Engineer, vol. 15, Nov. 1, 2016," TAIGA Publishing Co., Ltd., Japan Patent Office, Design Department. [Cited and provided on p. 2 of the Notices of Grounds of Rejection in counterpart JP Application Nos. 2016-024841 and 2016-024842, dated May 29, 2017.]

* cited by examiner

FIG.1

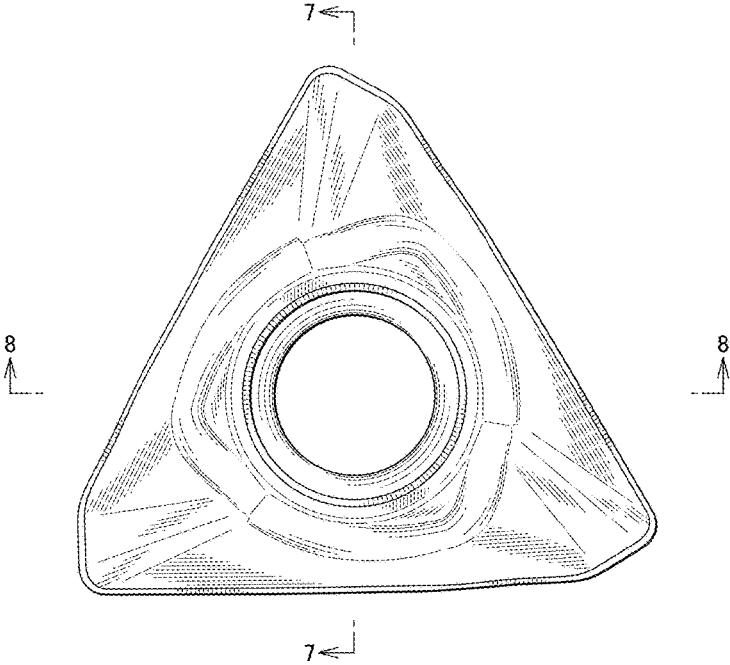

FIG.2

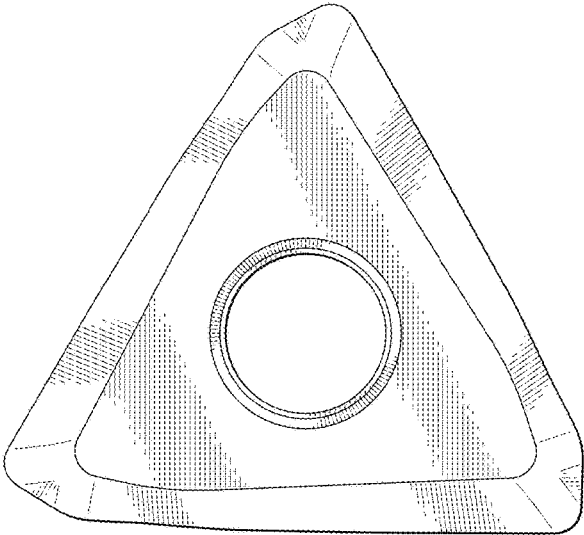

FIG.3

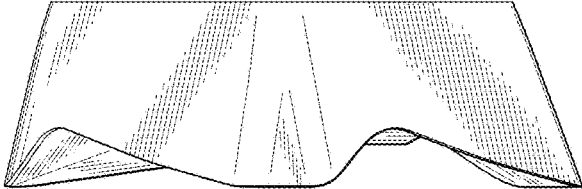

FIG.4

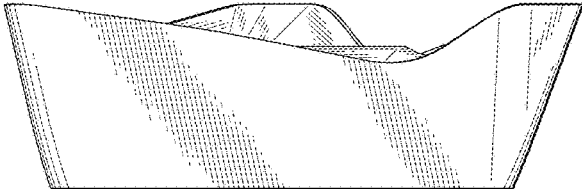

FIG.5

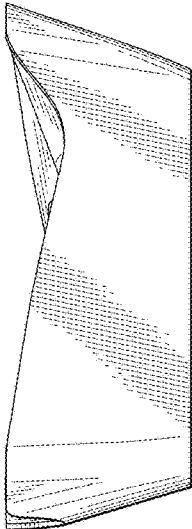

FIG.6

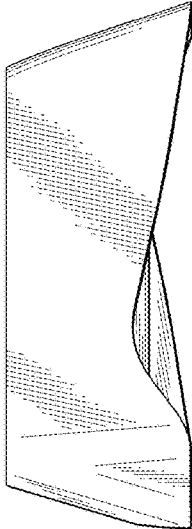

FIG.7

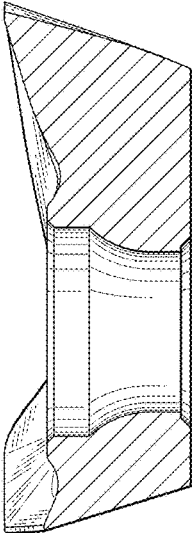

FIG.8

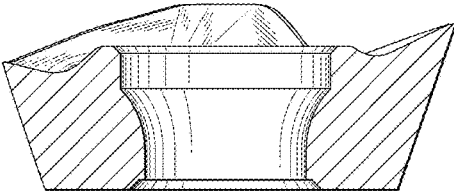

FIG.9

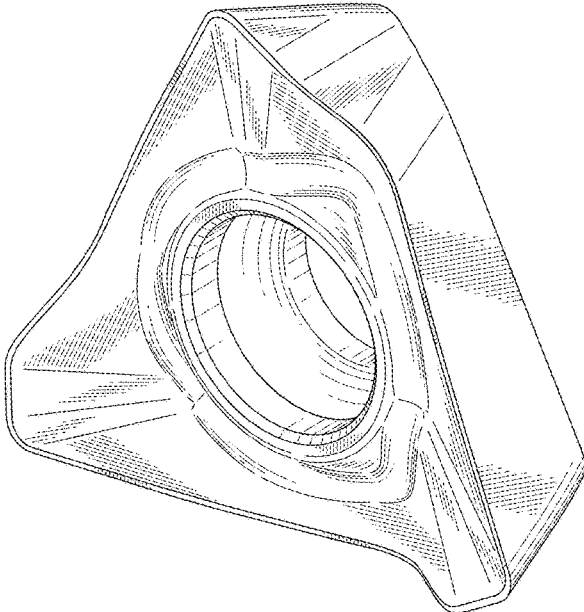

FIG.10

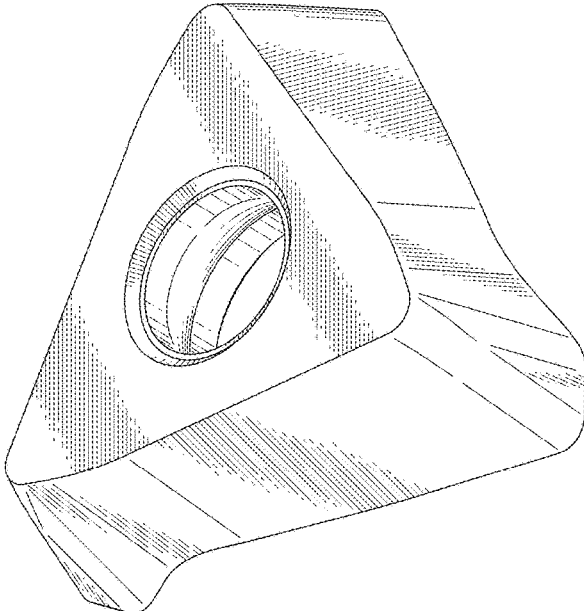

FIG.11

