



US 20090235941A1

(19) **United States**

(12) **Patent Application Publication**
Chida et al.

(10) **Pub. No.: US 2009/0235941 A1**

(43) **Pub. Date: Sep. 24, 2009**

(54) **FLAVOR BEAD AND CIGARETTE FILTER**

(30) **Foreign Application Priority Data**

(76) Inventors: **Masahiro Chida**, Tokyo (JP);
Yasuhiro Nakagawa, Tokyo (JP)

Dec. 13, 2006 (JP) 2006-336180

Mar. 22, 2007 (JP) 2007-075371

Correspondence Address:

BIRCH STEWART KOLASCH & BIRCH
PO BOX 747
FALLS CHURCH, VA 22040-0747 (US)

Publication Classification

(51) **Int. Cl.**
A24B 15/30 (2006.01)

(52) **U.S. Cl.** 131/275

(57) **ABSTRACT**

(21) Appl. No.: **12/476,596**

(22) Filed: **Jun. 2, 2009**

Related U.S. Application Data

(63) Continuation of application No. PCT/JP2007/073866,
filed on Dec. 11, 2007.

A flavor bead includes a particulate carrier, a glucan film supported by the particulate carrier, and a flavorant. The flavorant is supported by the flavor bead such that release of flavor from the flavorant is suppressed by the glucan film, but the flavor is released by the glucan film being at least partially dissolved when the glucan film contacts with tobacco mainstream smoke.

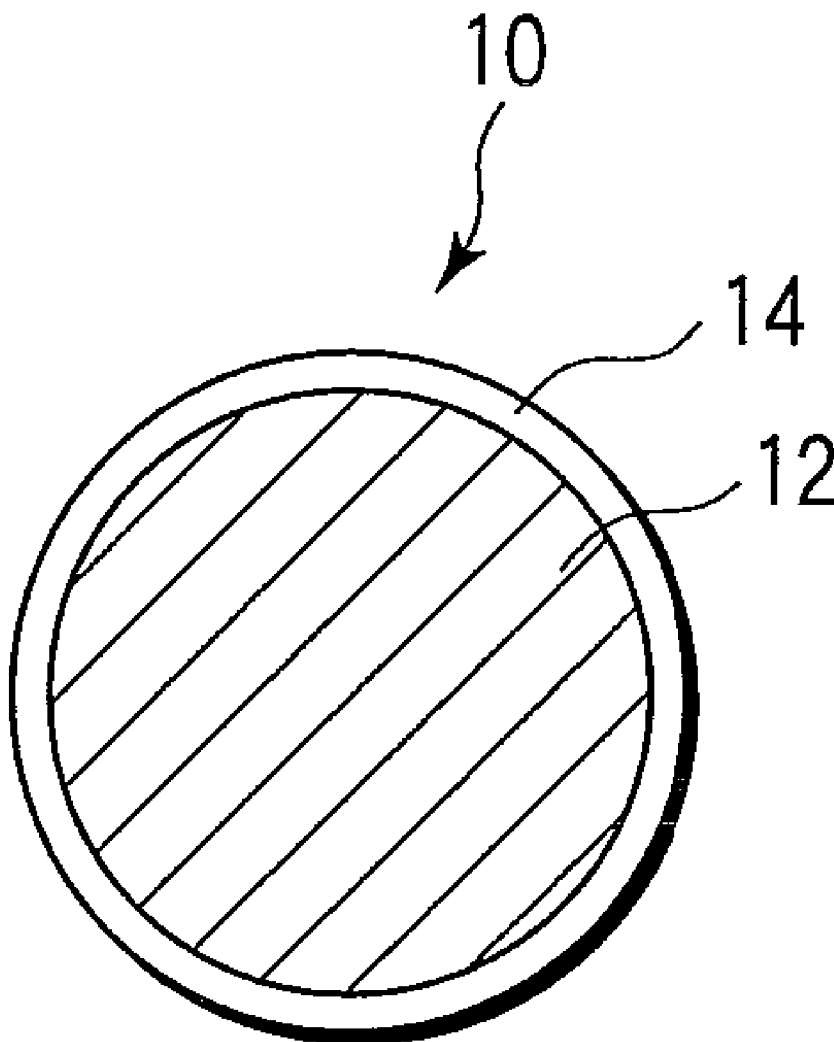

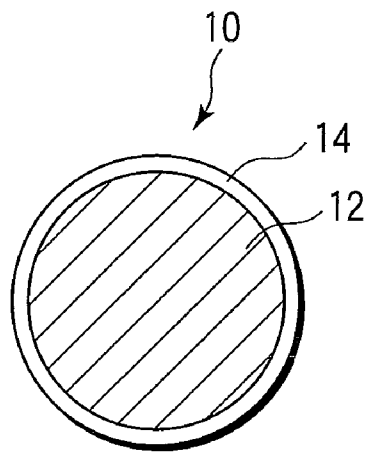

FIG. 1

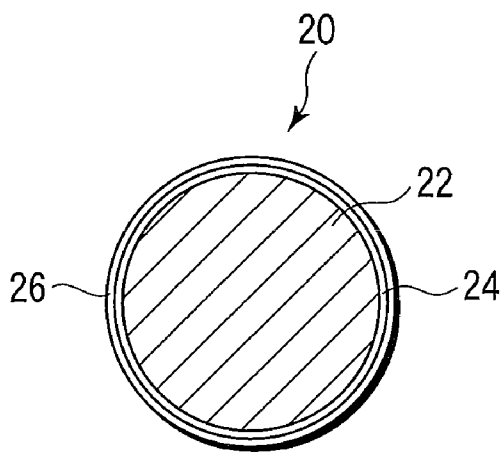

FIG. 2

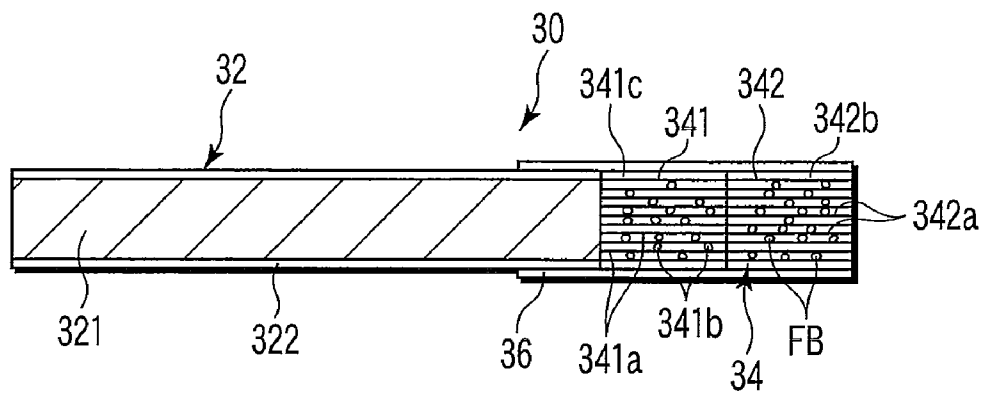

FIG. 3

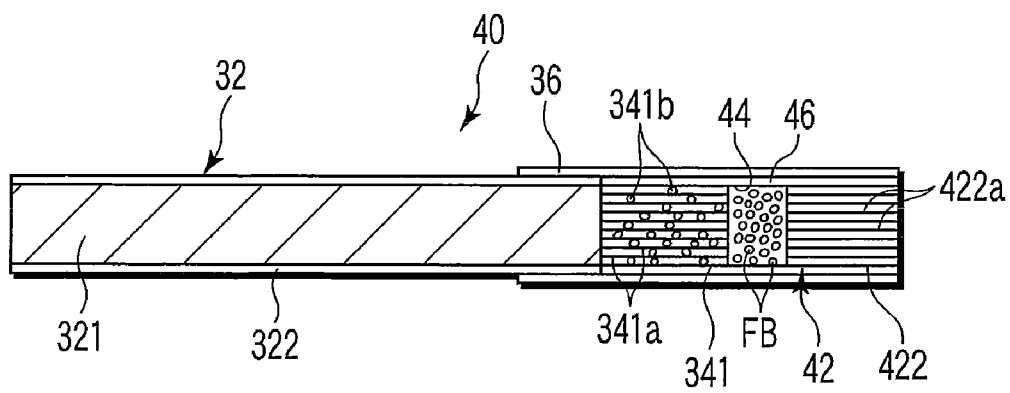

FIG. 4

FLAVOR BEAD AND CIGARETTE FILTER**CROSS REFERENCE TO RELATED APPLICATIONS**

[0001] This is a Continuation Application of PCT Application No. PCT/JP2007/073866, filed Dec. 11, 2007, which was published under PCT Article 21(2) in Japanese.

[0002] This application is based upon and claims the benefit of priority from prior Japanese Patent Applications No. 2006-336180, filed Dec. 13, 2006; and No. 2007-075371, filed Mar. 22, 2007, the entire contents of both of which are incorporated herein by reference.

BACKGROUND OF THE INVENTION

[0003] 1. Field of the Invention

[0004] The present invention relates to a flavor bead and a cigarette filter containing the same.

[0005] 2. Description of the Related Art

[0006] Flavorants added to cut tobacco include a primary flavorant as a casing sauce, and a secondary flavorant as a top flavor. The components of the secondary flavorant are relatively highly volatile, and are susceptible to pyrolysis. Therefore, the secondary flavorant contained in a cigarette evaporates during storage, which results in a decrease of the flavor during smoking. In addition, in a cigarette having a charcoal filter, the secondary flavorant migrates to and is adsorbed on the charcoal filter, which results in a further decrease of the flavor. The charcoal filter having the second flavorant adsorbed has decreased capability to remove the components of tobacco mainstream smoke.

[0007] Japanese Patent No. 2709077 discloses microcapsulating a secondary flavorant with a natural polysaccharide, and adding the microcapsules to a tobacco filter by a so-called cavity filling process. Since the flavorant is encapsulated in the microcapsules composed of the natural polysaccharide, it will not cause the migration or evaporation of the flavorant during storage, and thus will not deteriorate the capability of the charcoal filter to remove the components of tobacco mainstream smoke.

[0008] However, in the microcapsules, the flavor can be tasted only by crushing or grating them by fingers (application of external force) when smoking. The application of external force is bothersome. In addition, the flavor released by the application of external force will not uniformly spread over the filter, which results in erratic taste during smoking.

BRIEF SUMMARY OF THE INVENTION

[0009] Accordingly, the present invention is intended to provide a flavor bead and a cigarette filter which can suppress the evaporation and migration of a flavorant during non-smoking stages, and allow for stable tasting of the flavor during smoking stages without requiring the application of external force.

[0010] According to one aspect of the present invention, there is provided a flavor bead comprising a particulate carrier, a glucan film supported by the particulate carrier, and a flavorant, wherein the flavorant is supported by the flavor bead such that release of flavor from the flavorant is suppressed by the glucan film, but the flavor is released by the glucan film being at least partially dissolved when the glucan film contacts with tobacco mainstream smoke.

[0011] According to another aspect of the present invention, there is provided a cigarette filter including the flavor beads of the present invention.

BRIEF DESCRIPTION OF THE SEVERAL VIEWS OF THE DRAWING

[0012] FIG. 1 is an enlarged schematic cross sectional view of a flavor bead according to one embodiment of the present invention.

[0013] FIG. 2 is an enlarged schematic cross sectional view of a flavor bead according to another embodiment of the present invention.

[0014] FIG. 3 is a longitudinal cross sectional view of a cigarette provided with a filter according to one embodiment of the present invention.

[0015] FIG. 4 is a longitudinal schematic cross sectional view of a cigarette provided with a filter according to another embodiment of the present invention.

DETAILED DESCRIPTION OF THE INVENTION

[0016] Various embodiments of the present invention will be described below with reference to the drawings. Similar elements are designated by the same reference numerals throughout the drawings.

[0017] A flavor bead according to the present invention includes a particulate carrier, a glucan film supported by the particulate carrier, and a flavorant. The flavorant is supported by the flavor bead such that release of flavor from the flavorant is suppressed by the glucan film, but the flavor is released by the glucan film being at least partially dissolved when the glucan film contacts with tobacco mainstream smoke.

[0018] According to a first embodiment of the present invention, the glucan film contains the flavorant, and directly covers the surface of the particulate carrier. The flavor bead according to the first embodiment includes the particulate carrier, and the glucan film covering the surface of the particulate carrier and holding the flavorant.

[0019] According to a second embodiment of the present invention, the flavorant is a solid flavorant which directly covers the surface of the particulate carrier, and the glucan film covers the solid flavorant film. The flavor beads according to the second embodiment each include the particulate carrier, the menthol film covering the surface of the carrier, and the glucan film covering the surface of the menthol film.

[0020] The particulate carrier used in the present invention may be composed of particles of calcium carbonate, activated carbon, sugar crystals (for example, granulated sugar), or coffee beans. As the particulate carrier, particles having an average particle size of 75 μm to 2000 μm , e.g., 75 μm to 350 μm may be suitably used.

[0021] The glucan film is composed of, for example, pululan, maltodextrin or hydroxypropyl cellulose, and is water-soluble.

[0022] The flavorant may be one for food or tobacco use. Examples of such flavorant include lavender, cinnamon, cardamom, celery, clove, cascarilla, nutmeg, sandalwood, bergamot, geranium, honey essence, rose oil, vanilla, lemon, orange, mint, cinnamon, caraway, cognac, jasmine, chamomile, menthol, cassia, ylang ylang, sage, spearmint, fennel, pimento, ginger, anise, coriander, and coffee essential oils.

[0023] FIG. 1 is an enlarged schematic cross sectional view of a flavor bead 10 according to the first embodiment of the present invention. The flavor bead 10 includes a particulate

carrier (core) **12**, whose surface is covered by a glucan film **14**. The glucan film **14** contains the flavorant.

[0024] The glucan film **14** containing the flavorant may be formed from an aqueous solution or dispersion of the flavorant and glucan. In the aqueous solution or dispersion, the flavorant is preferably used in an amount corresponding to 20% or less (but more than 0%) of the weight of the glucan. The glucan film **14** is not particularly limited in its thickness. However, in view of releaseability of the flavor during smoking, the glucan film is preferably formed with glucan in an amount corresponding to 0.25% to 5% of the weight of the finished flavor bead.

[0025] The flavor bead according to the first embodiment may be produced, for example, by the following method. Namely, the particulate carriers composed of calcium carbonate or the like are charged into a fluidized-bed granulation drier, and an aqueous glucan solution or dispersion containing the flavorant is continuously or intermittently sprayed onto the surface of the particulate carriers while blowing, e.g., warm air at 80° C. or lower into the granulation drier, followed by drying. In this case, the carriers are immediately cooled depending on the type of the flavorant or the composition of the glucan solution. In this manner, a glucan film holding the flavorant is formed on the surface of the particulate carrier.

[0026] In the flavor bead according to the first embodiment, since the flavorant is contained within the glucan film, which has a low gas permeability, the evaporation and degradation of the flavorant during storage can be suppressed. Only after contact with tobacco mainstream smoke during smoking, the glucan film is partially dissolved mainly by highly polar components (for example, water) in the tobacco mainstream smoke, and releases the flavorant component which disperses into the mainstream smoke, thus allowing stable tasting of the flavor of the flavorant. The flavor bead of the present invention does not require the application of external force to taste the flavor as done in the case of microcapsules.

[0027] FIG. 2 is an enlarged schematic cross sectional view of a flavor bead **20** according to the second embodiment of the present invention. In the flavor bead **20**, the entire surface of a particulate carrier (core) **22** is covered by a film **24** of a solid flavorant such as menthol, and the entire surface of the solid flavorant film **24** is covered by a glucan film **26**.

[0028] As described later, the solid flavorant film **24** may be formed by finely pulverizing crystals of the solid flavorant such as menthol, mixing the resultant solid flavorant fine particles with the particulate carrier **12**, thereby adhering the solid flavorant fine particles to the particulate carrier **22**, melting the solid flavorant fine particles on the particulate carrier **22** by heating, and then recrystallizing the solid flavorant by cooling. In order to prevent the solid flavorant such as menthol from growing into columnar crystals during cooling, it is preferred that a crystal growth inhibitor such as a fatty acid, glycerol or propylene glycol be added to the solid flavorant. The crystal growth inhibitor may be used in an amount corresponding to 0.1 to 1.0% of the weight of the solid flavorant such as menthol. The solid flavorant film **14** may contain a flavorant other than the solid flavorant.

[0029] The solid flavorant film **24** is not particularly limited in its thickness. However, the solid flavorant film **24** is preferably formed with the solid flavorant in an amount corresponding to 1 to 20% of the weight of the finished flavor bead.

[0030] The glucan film **26** may be formed from an aqueous solution or dispersion of glucan. The glucan film **26** is not

particularly limited in its thickness. However, in view of holdability of the flavor of the solid flavorant at non-smoking stages and of releaseability of menthol during smoking, the glucan film **26** is preferably formed with glucan in an amount corresponding to 0.25% to 5% of the weight of the finished flavor bead.

[0031] The flavor bead according to the second embodiment may be produced by, for example, the following method. Namely, the particulate carriers and fine particles of the solid flavorant crystals, and as necessary, the crystal growth inhibitor and other flavorant are mixed and heated in a ribbon mixer. During the early stages of the mixing, the fine particles of the solid flavorant crystals adhere to the surfaces of the particulate carriers, and the fine particles of the solid flavorant crystals begin melting when the heating temperature reaches the melting point of the solid flavorant (for example, about 42° C. for menthol). Stirring and mixing are further continued thereby uniformly applying the molten solid flavorant to the surfaces of the particulate carriers. After the mixing under heating, the particulate carriers are immediately cooled by, for example, cooling the can body of the ribbon mixer, or blowing cold air into the ribbon mixer. The molten solid flavorant is recrystallized by the cooling treatment to cover the surfaces of the particulate carriers as a film. The particulate carriers covered with the solid flavorant films are charged into a fluidized-bed granulation drier, and an aqueous solution or dispersion of glucan is intermittently sprayed onto the particulate carriers while blowing, for example, warm air at 40° C. or lower into the granulation drier, followed by cooling. In this manner, a glucan film is formed on the surface of the solid flavorant film formed on the surface of the particulate carrier.

[0032] Alternatively, the flavor bead according to the second embodiment may also be produced by forming a solid flavorant film on the surfaces of the particulate carriers as described above, and spraying an aqueous solution or dispersion of glucan onto the particulate carriers having the solid flavorant films in a ribbon mixer or a rolling granulator, thereby covering the solid flavorant film with the glucan film, followed by cooling.

[0033] In the flavor bead according to the second embodiment, since the solid flavorant film formed on the surface of the particulate carrier is covered by the glucan film, which has a low gas permeability, menthol is prevented from evaporating or adhering to charcoal during storage under ordinary conditions. When the glucan film contacts with the hydrophilic components such as water contained in mainstream smoke emitted during smoking of the cigarette, the glucan film is partially deformed and dissolved, whereby the flavor is released from the underlying solid flavorant film and can be tasted. The flavor bead of the present invention does not require the application of external force to taste the flavor as done in the case of microcapsules.

[0034] A cigarette filter according to the present invention contains the flavor beads of the present invention.

[0035] A cigarette provided the filter of the present invention will be described below with reference to FIGS. 3 and 4. In FIGS. 3 and 4, similar elements are designated by the same reference numerals.

[0036] FIG. 3 is a schematic cross sectional view of a cigarette (filter-tipped cigarette) **30** provided with a cigarette filter according to one embodiment of the present invention. The filter-tipped cigarette **30** includes a cigarette portion **32** composed of a tobacco filler **321** such as cut tobacco wrapped with

a cigarette paper 322. The cigarette portion 32 is similar to that included in an ordinary cigarette.

[0037] A filter portion 34 is attached to one end of the cigarette portion 32. The filter portion 34 is composed of a charcoal filter section 341 provided directly adjacent to one end of the cigarette portion 32, and another filter section 342 containing the flavor beads provided at the downstream end of the charcoal filter section, viewed in the flow direction of mainstream smoke.

[0038] The charcoal filter section 341 is formed by wrapping, e.g., cellulose acetate fibers 341a, in which charcoal particles 341b are dispersed, with a filter wrapping paper 341c. The charcoal filter section 341 is similar to that included in an ordinary charcoal filter.

[0039] The filter section 342 containing the flavor beads is formed by wrapping, e.g., cellulose acetate fibers 342a, in which flavor beads FB of the present invention are dispersed, with a filter wrapping paper 342b.

[0040] The filter portion 34 composed of the filter sections 321 and 322 is attached to the cigarette portion 32 with a tipping paper 36.

[0041] FIG. 4 is a schematic cross sectional view of a cigarette (filter-tipped cigarette) 40 provided with a cigarette filter according to another embodiment of the present invention. In the filter-tipped cigarette 40, a filter portion 42 attached to the cigarette portion 32 with the tipping paper 36 is composed of a charcoal filter section 341 which is directly attached to one end of the cigarette portion 32, and a plain filter section 422 which is provided spaced apart from the charcoal filter section 341. The filter portion 42 is entirely wrapped with a filter wrapping paper 46. The plain filter section 422 is composed of, for example, tow of cellulose acetate fibers 422a. The flavor beads (FB) of the present invention are filled in a cavity 44 between the charcoal filter section 341 and the plain filter section 422.

[0042] The present invention will be further described below with reference to specific Examples, but the present invention should not be limited to these Examples.

Example 1

[0043] 2% by weight of a coffee oil was added to a previously prepared aqueous dispersion of pullulan containing 10% by weight of pullulan. The mixture was vigorously stirred in an emulsifier (emulsifier rotation speed of 2500 rpm), thus preparing a flavorant dispersion. On the other hand, 100 g of calcium carbonate particles having an average particle size of 250 μm were charged into a fluidized-bed granulation drier, and immediately the flavorant dispersion was intermittently sprayed onto the particles (repeated cycles each consisting of spraying for 1 minute and cessation for 30 minutes), while blowing warm air at 75° C. into the drier at a flow rate of 0.6 m/second, thereby spraying 10 g in total of the flavorant dispersion onto the surfaces of calcium carbonate particles, followed by drying. Thereafter, the inside of the fluidized bed was immediately cooled to room temperature, thus obtaining desired flavor beads.

Example 2

[0044] 100 g of calcium carbonate particles having an average particle size of 250 μm were charged into a fluidized-bed granulation drier, and an aqueous flavorant mixture solution containing 1% by weight of a tobacco flavorant and 9% by weight of pullulan, added with vanillin, was continually

sprayed onto the particles, while blowing warm air at 30° C. into the drier at a flow rate of 1.0 m/second, thereby spraying 5 g of the aqueous mixture solution onto the surfaces of the calcium carbonate particles, followed by drying. Thereafter, the temperature of the warm air was immediately decreased to room temperature, and the particles were cooled at a flow rate of 0.4 m/second, thus obtaining desired flavor beads.

Example 3

[0045] 1% by weight of coffee oil and 0.5% by weight of lecithin were added to a previously prepared aqueous dispersion of pullulan containing 10% by weight of pullulan. The mixture was vigorously stirred in an emulsifier (emulsifier rotation speed of 7500 rpm, 15 minutes), thus preparing a flavorant dispersion. On the other hand, 300 g of ground coffee bean particles having a particle size of 250 μm to 1.4 mm were charged into a rotating fluidized-bed granulation drier (SFC-MINI, manufactured by Freund Corporation), and the perforated disc at the bottom and the mixer blades to prevent lumping were rotated at about 500 rpm and about 400 rpm, respectively, while blowing warm air at 75° C. into the drier at a flow rate of 0.6 m/second, thereby forming a fluidized bed of the ground coffee particles. The flavorant dispersion kept at 40° C. was continuously sprayed onto the fluidized bed, thereby spraying 90 g in total of the flavorant dispersion on the surface of the ground coffee particles, followed by drying. Thereafter, the temperature of the warm air was immediately decreased to room temperature, and the particles were cooled at a flow rate of 0.4 m/second, thus obtaining desired flavor beads.

Example 4

[0046] Filter-tipped cigarettes as shown in FIG. 3 were made using the flavor beads obtained in Examples 1 to 3, respectively. In each case, the amount of the flavor beads added to the filter section 342 was 100 mg at maximum for 10 mm of the filter length. These cigarettes did not emit the flavor of the flavorant during storage. However, the flavor could be stably tasted when these cigarettes were smoked.

Example 5

[0047] 90 g of calcium carbonate particles having an average particle size of about 200 μm , 10 g of menthol fine powder, which had been obtained by pulverizing menthol crystals, and 0.5 g of glycerol were charged into a ribbon mixer. The contents were heated to 40° C. while stirring, and further mixed for 5 minutes. The menthol was completely molten, and allowed to adhere to and coat the calcium carbonate particles. Subsequently, cold air at 15° C. was blown into the ribbon mixer to cool the particles. Thus, the calcium carbonate particles whose surfaces were each coated with menthol crystal film were obtained. The calcium carbonate particles having the menthol films were charged into a fluidized-bed granulator, and immediately a 5% by weight aqueous solution of pullulan was intermittently sprayed on the particles while blowing warm air at 40° C. into the granulator at a flow rate of 1.0 m/second, thereby spraying 15 g in total of the pullulan aqueous solution onto the calcium carbonate

particles. Thereafter, the particles were cooled to 25° C., thus obtaining desired menthol-flavor beads.

Example 6

[0048] The filter-tipped cigarettes as shown in FIG. 3 were made using the menthol-flavor beads obtained in Example 5. The amount of the menthol-flavor beads added to the filter section 342 was 3 mg in terms of menthol per cigarette. The cigarettes did not emit the flavor of menthol under ordinary storage conditions. However, the menthol flavor could be stably tasted when these cigarettes were smoked.

What is claimed is:

1. A flavor bead comprising a particulate carrier, a glucan film supported by the particulate carrier, and a flavorant, wherein the flavorant is supported by the flavor bead such that release of flavor from the flavorant is suppressed by the glucan film, but the flavor is released by the glucan film being at least partially dissolved when the glucan film contacts with tobacco mainstream smoke.

2. The flavor bead according to claim 1, wherein the particulate carrier is selected from the group consisting of calcium carbonate particle, activated carbon particle, sugar crystal particle and coffee bean particle.

3. The flavor bead according to claim 1, wherein the glucan film is composed of pullulan.

4. The flavor bead according to claim 1, wherein the flavorant is selected from lavender, cinnamon, cardamom, cel-

ery, clove, cascarilla, nutmeg, sandalwood, bergamot, geranium, honey essence, rose oil, vanilla, lemon, orange, mint, cinnamon, caraway, cognac, jasmine, chamomile, menthol, cassia, ylang ylang, sage, spearmint, fennel, pimento, ginger, anise, coriander, and coffee essential oils.

5. The flavor bead according to claim 1, wherein the glucan film is formed with glucan in an amount corresponding to 0.25 to 5% of the total weight of the flavor bead.

6. The flavor bead according to claim 1, wherein the glucan film contains the flavorant, and directly covers the surface of the particulate carrier.

7. The flavor bead according to claim 6, wherein the flavorant is present in an amount corresponding to 20% or less of the weight of glucan.

8. The flavor bead according to claim 1, wherein the flavorant is a solid flavorant, which forms a film directly covering the surface of the particulate carrier, and the glucan film covers the film of the solid flavorant.

9. The flavor bead according to claim 8, wherein the solid flavorant comprises menthol.

10. The flavor bead according to claim 8, wherein the solid flavorant film is formed with the solid flavorant in an amount corresponding to 1 to 20% by weight of the total weight of the flavor bead.

11. A cigarette filter which contains a flavor bead according to claim 1.

* * * * *