



(43) International Publication Date
9 August 2012 (09.08.2012)

(51) International Patent Classification:
C10G 19/00 (2006.01) C09K 3/00 (2006.01)

(21) International Application Number:
PCT/US2012/023238

(22) International Filing Date:
31 January 2012 (31.01.2012)

(25) Filing Language: English

(26) Publication Language: English

(30) Priority Data:
13/017,861 31 January 2011 (31.01.2011) US

(71) Applicant (for all designated States except US): MERI-
CHEM COMPANY [US/US]; 5455 Old Spanish Trail,
Houston, TX 77023 (US).

(72) Inventors; and
(75) Inventors/Applicants (for US only): ZHANG, Tiejun [US/US]; 4320 Jonathan Street, Bellaire, TX 77401 (US). HARDY, K., Michael [US/US]; 4011 Appalachian Trail, Humble, TX 77345 (US). TURNER, V., Keith [US/US]; 9907 Green Meadow, Laporte, TX 77571 (US). BINCAZ, Ignacio, C. [AR/US]; 8909 Sungate Drive, Pearland, TX 77584 (US). VARADI, Tom [US/US]; 5350 Paisley Lane, Houston, TX 77096 (US).

(74) Agent: FRISCHKORN, David, M.; McDonnell Boehnen Hulbert & Berghoff LLP, 300 South Wacker Drive, Suite 3100, Chicago, IL 60606 (US).

(81) Designated States (unless otherwise indicated, for every kind of national protection available): AE, AG, AL, AM, AO, AT, AU, AZ, BA, BB, BG, BH, BR, BW, BY, BZ, CA, CH, CL, CN, CO, CR, CU, CZ, DE, DK, DM, DO, DZ, EC, EE, EG, ES, FI, GB, GD, GE, GH, GM, GT, HN, HR, HU, ID, IL, IN, IS, JP, KE, KG, KM, KN, KP, KR, KZ, LA, LC, LK, LR, LS, LT, LU, LY, MA, MD, ME, MG, MK, MN, MW, MX, MY, MZ, NA, NG, NI, NO, NZ, OM, PE, PG, PH, PL, PT, QA, RO, RS, RU, RW, SC, SD, SE, SG, SK, SL, SM, ST, SV, SY, TH, TJ, TM, TN, TR, TT, TZ, UA, UG, US, UZ, VC, VN, ZA, ZM, ZW.

[Continued on next page]

(54) Title: HYDROCARBON TREATMENT PROCESS

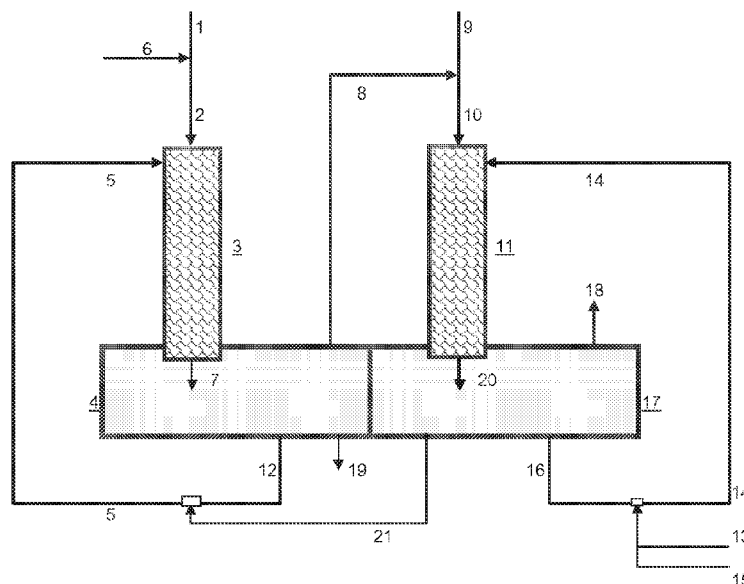

FIG. 1

(57) Abstract: In a catalytic treatment process, mercaptans in sour hydrocarbon are oxidized to disulfide oils using an aqueous treatment solution containing a chelated polyvalent metal catalyst, alkali metal hydroxide, and the alkali metal salt of at least one alcohol in a non-dispersive mixing apparatus wherein an upgraded hydrocarbon containing the disulfide oils is produced.

WO 2012/106290 A2

(84) Designated States (*unless otherwise indicated, for every kind of regional protection available*): ARIPO (BW, GH, GM, KE, LR, LS, MW, MZ, NA, RW, SD, SL, SZ, TZ, UG, ZM, ZW), Eurasian (AM, AZ, BY, KG, KZ, MD, RU, TJ, TM), European (AL, AT, BE, BG, CH, CY, CZ, DE, DK, EE, ES, FI, FR, GB, GR, HR, HU, IE, IS, IT, LT, LU, LV, MC, MK, MT, NL, NO, PL, PT, RO, RS,

SE, SI, SK, SM, TR), OAPI (BF, BJ, CF, CG, CI, CM, GA, GN, GQ, GW, ML, MR, NE, SN, TD, TG).

Published:

— *without international search report and to be republished upon receipt of that report (Rule 48.2(g))*

SPECIFICATION

TITLE

HYDROCARBON TREATMENT PROCESS

CROSS REFERENCE TO RELATED APPLICATIONS

[0001] The present application claims priority to U.S. Patent Application No. 13/017,861 filed January 31, 2011, the entire contents of which are incorporated herein by reference.

FIELD OF INVENTION

[0002] The invention relates to a method for treating liquid hydrocarbons in order to convert acidic impurities, such as mercaptans, to less odorous sulfur compounds. More specifically these impurities are oxidized to disulfide oils by contacting the hydrocarbon in the presence of oxygen with an aqueous treatment solution comprising a polyvalent chelated metal catalyst, an alcohol and an alkali metal hydroxide. An especially preferred treatment solution also includes a carboxylic acid.

BACKGROUND

[0003] The treatment of liquid hydrocarbons containing undesirable acidic species such as mercaptans is known and can be performed using either an extraction or a conversion process. The conversion processes are known as "sweetening" processes where an aqueous solution containing a mixture of an alkali metal hydroxide, such as sodium hydroxide, and a chelated metal catalyst is contacted with a hydrocarbon stream in the presence of an oxygen containing gas. An oxidation reaction occurs that converts the mercaptans to disulfide oils, which remain in the hydrocarbon phase during a subsequent step to separate the hydrocarbon from the aqueous solution. These sweetening processes work effectively on light hydrocarbon feeds with light mercaptan impurities.

[0004] The extraction processes, such as described in U.S. Patent Nos. 6,860,999; 6,960,291; 7,014,751; and 7,029,573, requires liquid-liquid mass transfer of the mercaptans from the hydrocarbon to an aqueous solution under anaerobic conditions, i.e., in the substantial absence of added oxygen. Such processes were especially effectively for removal of high molecular weight mercaptans (C₄ and higher) that are typically contained in heavier liquid hydrocarbon feeds. The aqueous solution preferably has two phases where

alkylphenols, such as cresols (in the form of the alkali metal salt), are combined with a polyvalent metal catalyst, and an alkali metal hydroxide in an aqueous extractant phase and a denser aqueous bottom phase that is substantially immiscible in the extractant. The alkylphenols were used to enhance the extraction of the heavier mercaptans. The metal catalyst is included in the solution to minimize entrainment of the aqueous solution in the treated hydrocarbon, particularly at the higher viscosities encountered at higher alkali metal hydroxide concentration. During mixing with a “sour” liquid hydrocarbon feed, the mercaptans are physically extracted (not converted) into the aqueous extractant phase, and after separation an upgraded hydrocarbon product is obtained that is substantially lower than the feed in mercaptan content. The extractant phase aqueous solution is then sent to an oxidation process where an oxygen containing gas is added and the metal catalyst present in the solution converts the mercaptans to disulfides. These alkylphenol based extraction processes are more complicated and difficult to operate principally because of the need to use a two-phase aqueous extraction solution, or a single phase compositionally located at the phase boundary between the one and two-phase regions.

[0005] There remains a need, therefore, for new hydrocarbon treatment processes that minimize operational difficulty and minimize the need for secondary processes to treat sulfur contaminants.

SUMMARY

[0006] Our invention is directed to an improved liquid hydrocarbon treatment process that combines the best of a conventional sweetening process with that of the more complicated extraction processes. Our process converts (as opposed to extracts) mercaptans including higher molecular weight mercaptans (C₄ and higher) to disulfide oils using an aqueous treatment solution and an oxidation reaction. The disulfide oils remain in the separated hydrocarbon product stream removed from the process. More specifically, our invention involves a process comprising a method for treating a hydrocarbon containing mercaptans where the liquid hydrocarbons containing mercaptans are combined with an oxygen containing gas to form a feed stream. That feed is contacted with an aqueous treatment solution comprising water, alkali metal hydroxide, a polyvalent chelated metal catalyst, and at least one alcohol, preferably having atmospheric boiling points of 100°C to 210°C, in a contactor vessel, where the catalyst and oxygen are used to convert the mercaptans via an oxidation reaction to disulfide oils. The contacting step forms a product

admixture that is directed to at least one separation zone, where an upgraded hydrocarbon stream containing the disulfide oils is separated from the admixture. The aqueous treatment solution is recirculated to treat more sour hydrocarbon, when necessary, after being replenished with make-up catalyst and/or other ingredients of the treatment solution.

[0007] In another embodiment, our invention involves a two-stage method for treating a hydrocarbon containing mercaptans, comprising, mixing a liquid hydrocarbon with air to form a first feed, then contacting the first feed in a first stage contactor with an aqueous treatment solution comprising water, alkali metal hydroxide, a chelated polyvalent metal catalyst, and at least one alcohol, preferably having atmospheric boiling points of 100°C to 210°C. The presence of the oxygen from the air and the catalyst oxidize most of the mercaptans in the first feed to disulfide oils to form a first admixture. This admixture is then settled in a first separation zone, where an upgraded hydrocarbon stream is separated that contains the disulfide oils from the settled first admixture. The separated upgraded hydrocarbon stream is then mixed with additional air to form a second feed. This second feed is further contacted in a second stage contactor with a second stream of the aqueous treatment solution to oxidize any remaining mercaptans to disulfide oils to form a second admixture. The second admixture is settled in a second separation zone, where a second upgraded hydrocarbon stream containing the disulfide oils is separated and removed from the process as a product stream. Similar steps may be repeated for the third and fourth stages, if needed.

[0008] Preferably, the contacting steps are performed using a contactor that reduces aqueous phase entrainment. Such contactors are configured to cause little or no agitation. One such contacting method employs a mass transfer apparatus comprising substantially continuous elongate fibers mounted in a shroud. The fibers are preferentially wetted by the aqueous treatment solution, and consequently present a large surface area to the hydrocarbon without substantial dispersion of the aqueous phase in the hydrocarbon.

[0009] The catalyst composition of our invention is preferably a liquid chelated polyvalent metal catalyst solution. Polyvalent catalysts include, but are not limited to, metal phthalocyanines, wherein the metal cation is selected from the group consisting of manganese (Mn), iron (Fe), cobalt (Co), nickel (Ni), copper (Cu), zinc (Zn), ruthenium (Ru), rodium (Rh), palladium (Pd), silver (Ag) etc. Catalyst concentration is from about 10 to about 10,000 ppm, preferably from about 20 to about 4000 ppm. The particular catalyst selected

may be included during preparation of the treatment solution and/or later added to the solution at the place of its use.

[0010] The aqueous treatment solution of this invention also includes one or more alcohols that have atmospheric boiling points of from 80°C to 225°C. These alcohols include, but are not limited to, methanol, ethanol, 1-propanol, 2-propanol, 2-methyl-1-propanol, 2-methyl-2-butanol, cyclohexanol, phenol, cresols, xylenols, hydroquinone, resorcinol, catechol, benzyl alcohol, ethylene glycol, propylene glycol. When mixed with an alkali metal hydroxide, an alkali metal salt of the alcohol is formed, preferably in a concentration of from about 5 to about 40 wt%, most preferably from about 10 to about 35 wt%. One type of preferred alcohol is an aromatic alcohol, which are compounds represented by a general formula of aryl-OH. The aryl can be phenyl, thiophenyl, indolyl, tolyl, xylyl, and alike. Preferred aromatic alcohols include phenol, cresols, xylenols, methylethyl phenols, trimethyl phenols, naphthols, alkylnaphthols, thiophenols, alkylthiophenols, and similar phenolics. Non-aromatic alcohols can be primary, secondary or tertiary alcohols, including methanol, ethanol, n-propanol, iso-propanol, cyclohexanol, 2-methyl-1-propanol, 2-methyl-2-butanol. A mixture of different alcohols can also be used. The preferred alcohols have an atmospheric boiling point of from about 100°C to about 210°C. The preferred alkali metal salts of alcohol include, but are not limited to, potassium cyclohexoxide, potassium isopropoxide, dipotassium propylene glycoxide, potassium cresylates and mixtures thereof.

[0011] In a most preferred treatment solution formulation, one or more carboxylic acids are included. Such acids include, but are not limited to, fatty acids, naphthenic acids, amino acids, keto acids, alpha hydroxy acids, dicarboxylic acids, and tricarboxylic acids. These acids also react with the alkali metal hydroxides to produce their alkali metal salts in concentrations from about 0 to about 40 wt%, preferably from about 5 to about 25 wt%. In general, the carboxylic acids can include alkanolic acids and naphthenic acids, where the alkanolic acids are represented by R-COOH, where R is a hydrogen or an alkyl group ranging from CH₃- (i.e. acetic acid) to CH₃(CH₂)₁₈- (i.e. arachidic acid). Naphthenic acids are a mixture of multiple cyclopentyl and cyclohexyl carboxylic acids with their main fractions preferably having a carbon backbone of 9 to 20 carbons. A mixture of multiple carboxylic acid compounds can also be used as part of the treatment solution.

[0012] The aqueous treatment solution of this invention contains an alkali metal hydroxide selected from lithium hydroxide (LiOH), sodium hydroxide (NaOH), potassium hydroxide (KOH), rubidium hydroxide (RbOH), and cesium hydroxide (CsOH). The alkali

metal hydroxide is present at a concentration that is more than sufficient to ensure all alcohols and carboxylic acids to form their corresponding alkali metal salts. Sodium hydroxide and especially potassium hydroxide are preferred.

[0013] Contacting of hydrocarbon feed with the aqueous treatment solution can be accomplished by any liquid-liquid mixing device, such as packed tower, bubble tray, stirred vessel, plug flow reactor, etc. Preferably, the contacting is performed using a contactor that achieves rapid liquid-liquid mass transfer without causing difficulties in obtaining quick and clean phase separation between the hydrocarbon and the aqueous treatment solution. Such contactors are configured to cause little or no agitation and reduce entrainment of aqueous solution in the hydrocarbon. One such contacting method employs a mass transfer apparatus comprising substantially continuous elongated fibers mounted in a shroud. The fibers are preferentially wetted by the aqueous treatment solution to form a thin film on the surface of fibers, and consequently present a large surface area to the hydrocarbon without substantial dispersion of the aqueous phase in the hydrocarbon. The rapid liquid-liquid mass transfer is enabled by both the large surface area and the functionality of the aqueous solution, which in turn enables the mercaptans to be transferred from the hydrocarbon to contacting with the thin film of the aqueous treatment solution. As mentioned earlier, two or more stages of contacting with an aqueous treatment solution may be adopted to achieve a greater extent of treating efficiency.

[0014] Any number of hydrocarbon feeds with boiling point up to about 350°C can be treated in our process using our aqueous treatment solution, including, but not limited to, kerosene, jet fuel, diesel, light and heavy naphtha. Other feedstocks may include straight run or cracked or selectively hydrotreated, LPG, naphtha, crude, crude condensates, and the like materials. Still another possible feedstock that can be used in the process of our invention would include crude oil, ranging from raw crude oil (i.e., untreated and straight out of ground) to partially or fully treated crudes that have been desalted and/or dewatered and/or de-odorized and mixtures of these. These so-called pipeline-ready crudes or refinery ready crude oil at the end of pipeline transportation can be used in our process as the liquid hydrocarbon feed. By the method of our invention, mercaptans in crude oil with 95 wt% boiling points of up to 600°C are converted into disulfide oils, prior to any fractionation.

[0015] These and other embodiments will become more apparent from the detail description of the preferred embodiment contained below.

BRIEF DESCRIPTION OF THE FIGURES

[0016] Figure 1 schematically illustrates a process flow diagram for one possible embodiment of this invention.

DETAILED DESCRIPTION

[0017] As mentioned, our invention involves treating a sour liquid hydrocarbon stream containing mercaptans by an oxidation process where the hydrocarbons are contacted with an oxygen containing gas and mixed with an aqueous treatment solution in a contactor to convert the mercaptans to disulfide oils, which remain in the hydrocarbon. An upgraded hydrocarbon stream (containing the disulfide oils) is separated from the aqueous treatment solution and removed from the process. In another embodiment, as disclosed more fully below, the process includes at least two stages of contacting, oxidation and separation.

[0018] The hydrocarbons treated in our process are liquid with a boiling point up to about 350°C and contain acidic species such as mercaptans. Representative hydrocarbons include straight run or cracked or selectively hydrotreated, one or more of natural gas condensates, liquid petroleum gas (LPG), butanes, butenes, gasoline streams, jet fuels, kerosenes, diesels, naphthas and the like. An example hydrocarbon is a cracked naphtha, such as FCC naphtha or coker naphtha, boiling in the range of about 35°C to about 230°C. Such hydrocarbon streams can typically contain one or more mercaptan compounds, such as methyl mercaptan, ethyl mercaptan, n-propyl mercaptan, isopropyl mercaptan, n-butyl mercaptan, thiophenol and higher molecular weight mercaptans. The mercaptan compound is frequently represented by the symbol RSH, where R is normal or branched alkyl, or aryl. The mercaptan sulfur is present in the hydrocarbons in an amount ranging from about 20 ppm to about 4000 ppm by weight, depending on the liquid hydrocarbon stream to be treated. The mercaptans range in molecular weight upwards from about C₄ or C₅, and may be present as straight chain, branched, or both. Specific types of mercaptans which may be converted to disulfide material by the oxidation process of this invention will include methyl mercaptan, ethyl mercaptan, propyl mercaptan, butyl mercaptan, pentyl mercaptan, hexyl mercaptan, heptyl mercaptan, octyl mercaptan, nonyl mercaptan, decyl mercaptan, undecyl mercaptan, dodecyl mercaptan, tridecyl mercaptan, tetradecyl mercaptan, pentadecyl mercaptan, hexadecyl mercaptan, heptadecyl mercaptan, octadecyl mercaptan, nonadecyl mercaptan, various mercaptobenzothiazoles, hydroxy mercaptans such as mercaptoethanol, cysteine,

aromatic mercaptans such as thiophenol, methyl-substituted thiophenol isomers, ethyl-substituted thiophenol isomers, propyl-substituted thiophenol isomers, etc.

[0019] In some cases, the hydrocarbons to be treated in our process have been hydrotreated to remove undesirable sulfur species and other heteroatoms from cracked naphtha. Unfortunately, hydrogen sulfide formed during hydrotreating reacts with olefins to form mercaptans, which are referred to as reversion or recombinant mercaptans to distinguish them from the mercaptans present in the cracked naphtha conducted to the hydrotreater. Such reversion mercaptans generally have a molecular weight ranging from about 90 to about 160 g/mole, and generally exceed the molecular weight of the mercaptans formed during heavy oil, gas oil, and resid cracking or coking, as these typically range in molecular weight from 48 to about 76 g/mole. The higher molecular weight of the reversion mercaptans and the branched nature of their hydrocarbon component make them more difficult to remove from the naphtha using conventional caustic extraction.

[0020] Our improved oxidation process using an aqueous treatment solution containing at least one alcohol and an alkali metal hydroxide can treat a hydrotreated naphtha boiling in the range of about 55°C to about 180°C and containing reversion mercaptan sulfur in an amount ranging from about 10 to about 100 wppm, based on the weight of the hydrotreated naphtha. Likewise, our process can treat a selectively hydrotreated hydrocarbon, i.e., one that is more than 80 wt. % (more preferably 90 wt. % and still more preferably 95 wt. %) desulfurized compared to the hydrotreater feed but with more than 30% (more preferably 50% and still more preferably 60%) of the olefins retained based on the amount of olefin in the hydrotreater feed.

[0021] Unlike prior known processes that use a two-phase treatment solution in the absence of oxygen, our process uses an aqueous treatment solution in conjunction with an added oxygen-containing gas that causes the mercaptans in the hydrocarbon feed to oxidize to disulfide oils, which remain in the hydrocarbon phase. The treatment solution can be prepared by adding metal phthalocyanine catalyst to an aqueous solution of alkali metal hydroxide and at least one alcohol. Another preferred treatment solution further contains at least one carboxylic acid, such as naphthenic or ethylhexanoic acid.

[0022] Figure 1 included herein schematically illustrates only one of the possible process flow schemes useful for performing the process of converting sulfur compounds found in a hydrocarbon stream taught by the invention. The process of our invention will be described in detail in conjunction with a description of the illustrated flow scheme. Before turning to the figure in detail, however, it should be understood that while the particular

arrangement of unit operations shown in the figure may be used to covert sulfur containing impurities to less obnoxious sulfur compounds, those skilled in the art will readily appreciate how to modify the flow schemes to permit the catalytic oxidation of sulfur compounds in liquid hydrocarbon feed streams.

[0023] Figure 1 shows a two-stage process where a liquid hydrocarbon feed containing mercaptans 1 is mixed with an oxygen containing gas stream 6, such as air. This mix 2 is then fed to contactor 3, where the air/hydrocarbon mix is contacted with stream 5, which contains an aqueous treatment solution of this invention. The contacting between the treatment solution and the hydrocarbon is liquid-liquid and can be accomplished in conventional contacting equipment, such as packed tower, bubble tray, stirred vessel, fiber contacting, rotating disc contactor or other contacting apparatus. As illustrated, a FIBER FILM® contactor 3, sold by the Merichem Company, is preferred. Such contactors are characterized by large surface areas provided by a mass of hanging thin ribbons of metal or other materials contained in a vertical shroud that allows mass transfer in a non-dispersive manner. These type of contactors are described in U.S. Pat. Nos. 3,997,829; 3,992,156; and 4,753,722. While contacting temperature and pressure may range from about 0°C to about 150°C and from 0 psig to about 500 psig, preferably the contacting occurs at a temperature in the range of about 25°C to about 100°C and a pressure in the range of about 0 psig to about 300 psig. When the hydrocarbon feed has a low atmospheric boiling point, higher pressures during contacting may be desirable to ensure that the contacting with the hydrocarbon occurs in the liquid phase.

[0024] During the contacting step the mercaptans are oxidized to disulfide oils that ultimately remain in the hydrocarbon phase. The admixture of hydrocarbon and treatment solution 7 exits the bottom of contactor 3 and is directed to a first separation zone 4 where the liquid hydrocarbon containing the disulfide oils is allowed to separate from the aqueous treatment solution via gravity settling. The separated upgraded liquid hydrocarbon is removed via line 8 and then combined with a second air stream 9 to form stream 10 that enters a second FIBER FILM® contactor 11. The air/hydrocarbon mix in stream 10 is combined with a second stream of treatment solution 14. Treatment solution streams 5 and 14 comprise recycled treatment solutions removed from separation zones 4 and 17 and make-up fresh treatment solution 13 and catalyst 15. A portion of the treatment solution is removed from the first separation zone 4 as stream 19 for disposal and from the second separation zone 17 as stream 21 to be mixed with stream 12. Any remaining mercaptans in the hydrocarbon are further oxidized in the second contactor 11 to disulfide oils. Admixture 20 is directed

from contactor 11 into separation zone 17 where a product hydrocarbon stream 18 containing the disulfide oils is removed from the process.

[0025] The foregoing description of the specific embodiments will so fully reveal the general nature of the invention that others can, by applying current knowledge, readily modify and/or adapt for various application such specific embodiments without departing from the generic concept, and therefore such adaptations and modifications are intended to be comprehended within the meaning and range of equivalents of the disclosed embodiments. It is to be understood that the phraseology or terminology herein is for the purpose of description and not of limitation.

[0026] The various aspects of the present invention will be more fully understood and appreciated by reference to the following examples. These examples not only demonstrate the interrelationship between the aqueous treatment solution of our invention used in the process taught by the invention and certain process variables, but also the significantly improved effectiveness of the present invention in reducing mercaptan sulfur compound concentrations in contaminated feed streams, as compared to prior art processes.

EXAMPLES

[0027] Four sets of comparison experiments are provided to demonstrate the enhanced treating efficiency of the aqueous treatment solution of our invention. In the first set, conventional caustic solutions are used to treat a sour jet fuel for sweetening. In the second set, one embodiment of our treatment solution is shown to substantially improve the treating efficiency. In the third set, five different compositions of our treatment solution are used to treat the sour jet fuel to show that the treating efficiency is further substantially improved by including a carboxylic acid.

[0028] The treating (i.e. sweetening) efficiency of a treating solution was experimentally determined in a laboratory bench-top batch reactor. A sour jet fuel feed having boiling point of 123°C to 343°C was obtained from a refinery plant. To each volume of an aqueous treating solution in a batch reactor, five volumes of this sour hydrocarbon were charged and the contents were mixed. The reactor content was kept at 38°C in the presence of oxygen that exceeded the stoichiometric requirement for full oxidation of mercaptans into disulfide oil. After a designated length of reaction time, the hydrocarbon phase was separated from the aqueous phase and analyzed to determine its mercaptan concentration. The mercaptan concentration as a function of reaction time was correlated with a kinetic rate equation to determine oxidation rate constant.

[0029] The performance advantage of the test treatment solutions is represented by an enhancement factor, E , that is substantially greater 1. The enhancement factor is defined as the ratio of the rate constant obtained with a treatment solution of our invention to the rate constant obtained with conventional 15 wt% NaOH under identical conditions. In other words, the enhancement factor represents the extent of improvement in treating efficiency relative to 15 wt% NaOH.

Examples 1- 3

[0030] In commercially practiced sweetening technologies, sodium hydroxide solution are conventionally used as the aqueous treating solution. Potassium hydroxide solution is rarely used for this purpose. Nevertheless, three caustic solutions were prepared to contain 15 wt% NaOH, 22 wt% KOH and 35 wt% KOH, respectively. Each solution was added with the same concentration of a cobalt phthalocyanine catalyst and tested to treat a sample of sour kerosene containing 38 ppm weight of mercaptan sulfur. The results of enhancement factors, E , are listed in Table 1. The cobalt phthalocyanine catalyst is commercially marketed by Merichem.

[0031] By definition, the 15 wt% NaOH solution has an enhancement factor, E , of 1.0. Table 1 illustrates that the 22 wt% KOH treatment solution did not change the enhancement factor and offers essentially the same treating efficiency as the 15 wt% NaOH solution. Increasing the caustic strength to 35 wt% KOH yielded a slight improvement of the enhancement factor to 3.5, indicating that a more concentrated KOH solution does, to some extent, enhance the treating efficiency as compared to 15 wt% NaOH.

Table 1

Example	Aqueous Solution	Enhancement Factor, E
Example 1	15 wt% NaOH	1.0 *
Example 2	22 wt% KOH	1.0 **
Example 3	35 wt% KOH	3.5 **

* By definition; ** Relative to 15 wt% NaOH.

Example 4

[0032] This example shows the advantage of an aqueous solution of this invention that contains a polyvalent catalyst, an aromatic alcohol, and an alkali metal hydroxide. 125.2 grams of 45% potassium hydroxide, 36.8 grams of cresol, and 37.2 grams of water were mixed thoroughly. The resulting solution contained 24.9 wt% potassium cresylate and 18.6

wt% free potassium hydroxide. To this aqueous solution was added 0.80 gram of cobalt phthalocyanine catalyst.

[0033] The treatment solution as prepared above was tested to treat a sample of sour jet fuel containing about 38 ppm weight of mercaptan sulfur and enhancement factors were calculated and reported in Table 2.

Table 2

Example	Enhancement Factor, <i>E</i>
Example 14	15.3

[0034] Table 2 shows that the aqueous treatment solution of our invention provides an enhancement factor of 15.3. In other words, the sweetening of the jet fuel is 15 times faster when it is treated with the aqueous solution of this invention as compared to 15 wt% NaOH.

Examples 5-9

[0035] These examples show that the effectiveness of the treatment solutions of this invention is further substantially improved by including a carboxylic acid in the presence of an alcohol. Naphthenic acid and ethylhexanoic acid are examples of carboxylic acids. Cyclohexanol, iso propanol, propylene glycol and alkylphenol are examples of such alcohols.

[0036] Example 5 – 125.2 grams of 45% potassium hydroxide, 34.2 grams of cyclohexanol, 34.2 grams of naphthenic acid, and 5.6 grams of water were mixed thoroughly. The resulting solution contained 23.6 wt% potassium cyclohexoxide, 13.5 wt% free potassium hydroxide, and 20.6 wt% potassium naphthenate. To this solution was added 0.80 gram of cobalt phthalocyanine catalyst.

[0037] Example 6 – 125.2 grams of 45% potassium hydroxide, 20.4 grams of iso-propanol, 34.2 grams of naphthenic acid, and 19.3 grams of water were mixed thoroughly. The resulting solution contained 16.7 wt% potassium iso-propoxide, 13.5 wt% free potassium hydroxide, and 20.6 wt% potassium naphthenate. 0.80 gram of cobalt phthalocyanine catalyst was added to the solution.

[0038] Example 7 – 125.2 grams of 45% potassium hydroxide, 26.0 grams of propylene glycol, 34.2 grams of naphthenic acid, and 13.9 grams of water were mixed thoroughly. The resulting solution contained 25.9 wt% dipotassium propylene glycoxide, 13.5 wt% free potassium hydroxide, and 20.6 wt% potassium naphthenate. 0.80 gram of cobalt phthalocyanine catalyst was added to the solution.

[0039] Example 8 – 125.2 grams of 45% potassium hydroxide, 36.8 grams of a mixed cresylic acid that contained 23 wt% phenol, 49 wt% cresols, 17 wt% xylenols, 7 wt% ethylphenols and 3 wt% trimethylphenol, 34.2 grams of naphthenic acid, and 3.0 grams of water were mixed thoroughly. The resulting solution contained 24.9 wt% potassium cresylates, 13.5 wt% free potassium hydroxide, and 20.6 wt% potassium naphthenate. 0.80 gram of cobalt phthalocyanine catalyst was added to the solution.

[0040] Example 9 – 125.2 grams of 45% potassium hydroxide, 36.8 grams of cresol, 26.4 grams of ethylhexanoic acid, and 10.8 grams of water were mixed thoroughly. The resulting solution contained 24.9 wt% potassium cresylate, 13.5 wt% free potassium hydroxide, and 16.7 wt% potassium ethylhexanoate. 0.80 gram of cobalt phthalocyanine catalyst was added to the solution.

[0041] The aqueous treatment solutions of Examples 5 to 9 were individually tested with a sample of sour jet fuel containing about 38 ppm weight of mercaptan sulfur. The results of enhancement factors are listed in Table 3. As Table 3 clearly shows, the aqueous treatment solutions of our invention provides enhancement factors of from 33.6 to 75.7. In other words, as compared to 15 wt% NaOH, the sweetening of the jet fuel is 34 to 76 faster when it is treated with the treatment solutions of our invention as compared to 15 wt% NaOH.

Table 3

Example	Enhancement Factor, <i>E</i>
Example 5	51.1
Example 6	42.0
Example 7	71.5
Example 8	75.7
Example 9	33.6

Examples 10 - 11

[0042] The essential role of alcohol and alkali metal hydroxide in the aqueous treatment solutions of this invention is shown in Examples 10 to 11.

[0043] Example 10 – 117.3 grams of 30% ammonium hydroxide, 36.8 grams of cresol, 34.2 grams of naphthenic acid, and 10.9 grams of water were mixed thoroughly. The resulting solution contained 21.3 wt% ammonium cresylate, 8.4 wt% free ammonium hydroxide, and 18.7 wt% ammonium naphthenate. 0.80 gram of cobalt phthalocyanine catalyst was added to the solution.

[0044] Example 11 – 125.2 grams of 45% potassium hydroxide, 34.2 grams of naphthenic acid, and 39.8 grams of water were mixed thoroughly. The resulting solution contained 23.0 wt% free potassium hydroxide and 20.6 wt% potassium naphthenate. 0.80 gram of cobalt phthalocyanine catalyst was added to the solution.

[0045] The solutions of Examples 10 to 11 were individually tested to treat a sample of sour jet fuel containing about 38 ppm weight of mercaptan sulfur. The results of enhancement factors are listed in Table 4. Table 4 illustrates that a substitution of alkali metal hydroxide with ammonium hydroxide (Example 10) or the absence of alcohol (Example 11) results in a great loss of treating efficiency, with enhancement factors dropped to 0.7 and 5.1, respectively. This is in sharp contrast to enhancement factors of 33.6 to 75.7 for the aqueous treatment solutions of this invention as presented in Table 3.

Table 4

Example	Enhancement Factor, <i>E</i>
Example 10	0.7
Example 11	5.1

Example 12

[0046] This example demonstrates the execution of treating a sour jet fuel using an aqueous solution of this invention in a pilot scale FIBER FILM® Contactor in comparison to conventional 15 wt% NaOH solution. FIBER FILM® Contactor is a proprietary non-dispersive liquid-liquid mass transfer device invented and commercialized by Merichem as indicated by multiple US patents. The sour jet fuel contained 26 ppm weight of mercaptan sulfur. When conventional 15 wt% NaOH was used, the jet fuel was treated to 18 ppm weight of mercaptan sulfur or a 31% reduction. In contrast, when an aqueous treatment solution of this invention was used, the jet fuel was treated to 2 ppm weight of mercaptan sulfur or a 92% reduction.

[0047] The means, materials, and steps for carrying out various disclosed functions may take a variety of alternative forms without departing from the invention. Thus, the expressions "means to . . ." and "means for . . .", or any method step language as may be found in the specification above or the claims below, followed by a functional statement, are intended to define and cover whatever structural, physical, chemical or electrical element or structure, or whatever method step, which may now or in the future exist which carries out the recited function, whether or not precisely equivalent to the embodiment or embodiments disclosed in the specification above, i.e., other means or steps for carrying out the same

function can be used; and it is intended that such expressions be given their broadest interpretation within the terms of the following claims.

CLAIMS

1. A method for treating a hydrocarbon containing mercaptans, comprising,
 - (a) contacting a crude oil feed containing mercaptans in the presence of oxygen in a contactor with a treatment solution comprising water, alkali metal hydroxide, a chelated polyvalent metal catalyst, and at least one alcohol present as its alkali metal salt;
 - (b) oxidizing the mercaptans to disulfide oil in the contactor; and
 - (c) recovering the crude oil and disulfide oil as an upgraded crude oil product.
2. The method of claim 1 wherein the alcohol used to form its alkali metal salt has an atmospheric boiling point of from 80°C to 225°C.
3. The method of claim 1 wherein the alcohol is present in the solution at a concentration in the range from about 5 to about 40 wt% as its alkali metal salt.
4. The method of claim 1 wherein the alkali metal salt of the alcohol is selected from the group consisting of potassium cyclohexoxide, potassium iso-propoxide, dipotassium propylene glycoxide, potassium alkylphenolates and mixtures thereof.
5. The method of claim 1 wherein the chelated polyvalent metal catalyst is cobalt phthalocyanine.
6. The method of claim 1 wherein the chelated polyvalent metal catalyst is iron phthalocyanine.
7. The method of claim 1 wherein the feed is mixed with an oxygen source prior to contact with the treatment solution;
8. The method of claim 1 wherein the oxygen is present at a level that is approximately equal to or exceeds the stoichiometric requirement for full oxidation of mercaptans into disulfide oil.

9. The method of claim 1 wherein the oxygen is present as an oxygen containing gas that contains 1 to 100 % oxygen by volume.

10. The method of claim 9 wherein the oxygen gas is air.

11. The method of claim 1 wherein the upgraded crude oil product is contacted in a second stage contactor in the presence of oxygen with a solution of water, alkali metal hydroxide, a chelated polyvalent metal catalyst, and at least one alcohol present as its alkali metal salt; and then a second stream of an crude oil hydrocarbon is separated from the second stage contactor.

12. The method of claim 1 wherein the contacting of the feed with the treatment solution forms an admixture that flows over and along fibers.

13. The method of claim 12 wherein the admixture co-currently flows over fibers.

14. The method of claim 12 wherein the fibers are selected from the group consisting of metallic fibers, polymeric fibers, carbonaceous fibers, and mixtures thereof.

15. The method of claim 11 wherein the fibers are selected from the group of porous fibers, non-porous fibers, and mixtures thereof.

16. The method of claim 1 wherein the crude oil has 95 wt.% boiling points of up to 600°C.

17. The method of claim 1 wherein the catalyst is present in the treatment solution in an amount ranging from about 10 to about 10,000 wppm, based upon the weight of the treatment solution.

18. The method of claim 1 wherein the treatment solution contains about 5 wt. % to about 40 wt. % dissolved alkali metal salts of alcohols, about 10 to about 10,000 wppm dissolved catalyst, about 5 wt. % to about 40 wt. % dissolved alkali metal hydroxide, and water as balance.

19. The method of claim 1 wherein the alcohols are selected from the group consisting of cyclohexanol, iso-propoanol, alkylphenols, propylene glycol, and mixtures thereof.
20. The method of claim 1 wherein the separated stream of upgraded crude oil containing disulfide oil is contacted with an aqueous stream containing an alkyl metal hydroxide.
21. The method of claim 1 wherein the treatment solution comprises at least one carboxylic acid.
22. The method of claim 21 wherein the carboxylic acids are present in the treatment solution in the range from about 0.5 wt.% to about 40 wt.% as their alkali metal salts.
23. The method of claim 21 wherein the carboxylic acids are naphthenic acids containing a mixture of multiple cyclopentyl and cyclohexyl carboxylic acids with their main fractions preferably having a carbon backbone of 9 to 20 carbons.
24. The method of claim 21 wherein the carboxylic acid is ethylhexanoic acid.
25. The method of claim 1 wherein the oxidized mercaptans, crude oil and treatment solution is directed to a separation zone and allowed to separate to obtain the upgraded crude oil product and to recover the treatment solution.
26. An aqueous solution composition for treating a crude oil containing mercaptans comprising water, alkali metal hydroxide, an chelated polyvalent metal catalyst, at least one carboxylic acid present as an alkali metal salt, and at least one alcohol present as an alkali metal salt.
27. The composition of claim 26 wherein the alkali metal hydroxide is selected from the group consisting of sodium hydroxide, potassium hydroxide, and mixtures thereof.

28. The composition of claim 26 wherein the alcohols have atmospheric boiling point from 100°C to 210°C.
29. The composition of claim 26 wherein the alcohol is selected from the group consisting of cyclohexanol, iso-propanol, propylene glycol, alkylphenols, and mixtures thereof.
30. The composition of claim 29 wherein the alkylphenols are selected from the group consisting of phenol, cresols, xylenols, trimethylphenol, and mixtures thereof.
31. The composition of claim 26 wherein the carboxylic acids are selected from the group consisting of naphthenic acids, ethylhexanoic acid, and mixtures thereof.
32. The composition of claim 26 wherein the chelated polyvalent metal catalyst is selected from the group consisting of cobalt phthalocyanine, iron phthalocyanine, and mixtures thereof.
33. A two-stage method for treating a hydrocarbon containing mercaptans comprising,
- (a) contacting a first feed containing crude oil and mercaptans in the presence of oxygen in a contactor with a treatment solution comprising water, alkali metal hydroxide, a chelated polyvalent metal catalyst, and at least one alcohol present as its alkali metal salt;
 - (b) oxidizing the mercaptans to disulfide oil in the contactor;
- recovering the crude oil and disulfide oil as a first upgraded crude oil product from a first separation zone;
- (d) mixing the recovered first upgraded crude oil product with oxygen to form a second feed;
 - (e) contacting the second feed with treatment solution in a second stage contactor to oxidize any remaining mercaptans to disulfide oils; and
 - (f) recovering the crude oil and disulfide oil as a second upgraded crude oil product from a second separation zone.
34. The method of claim 33 wherein, during the contacting of steps (a) and (e) the feeds and treatment solutions are applied to and flow over and along fibers.

35. The method of claim 33 wherein the crude oil has 95 wt.% boiling points of up to 600°C.

36. The method of claim 33 wherein the second upgraded crude oil product is contacted with an aqueous stream containing an alkyl metal hydroxide.

37. The method of claim 33 wherein the oxygen is obtained from air or oxygen-enriched air.

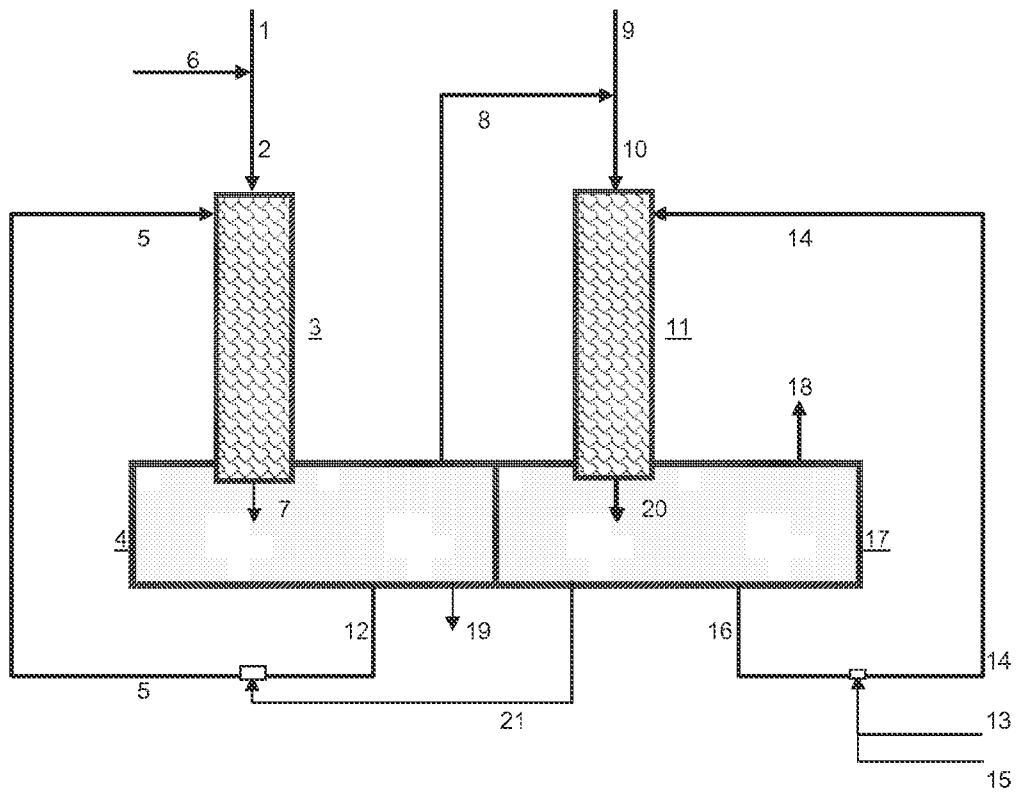

FIG. 1