

(19) World Intellectual Property Organization  
International Bureau



(43) International Publication Date  
19 April 2012 (19.04.2012)

PCT

(10) International Publication Number  
**WO 2012/050614 A1**

(51) International Patent Classification:  
*H01Q 1/00* (2006.01)

(21) International Application Number:  
PCT/US2011/001755

(22) International Filing Date:  
14 October 2011 (14.10.2011)

(25) Filing Language: English

(26) Publication Language: English

(30) Priority Data:  
61/455,171 15 October 2010 (15.10.2010) US

(71) Applicant (for all designated States except US):  
**SEARETE LLC** [US/US]; 11235 SE 6th Street, Suite 200, Bellevue, Washington 98004 (US).

(72) Inventor; and

(75) Inventor/Applicant (for US only): **KUNDTZ, Nathan** [US/US]; 10041 NE 130th Lane, Kirkland, Washington 98034 (US).

(74) Agents: **STEWART, John C.** et al.; 11235 SE 6th Street, Suite 200, Bellevue, Washington 98004 (US).

(81) Designated States (unless otherwise indicated, for every kind of national protection available): AE, AG, AL, AM, AO, AT, AU, AZ, BA, BB, BG, BH, BR, BW, BY, BZ,

CA, CH, CL, CN, CO, CR, CU, CZ, DE, DK, DM, DO, DZ, EC, EE, EG, ES, FI, GB, GD, GE, GH, GM, GT, HN, HR, HU, ID, IL, IN, IS, JP, KE, KG, KM, KN, KP, KR, KZ, LA, LC, LK, LR, LS, LT, LU, LY, MA, MD, ME, MG, MK, MN, MW, MX, MY, MZ, NA, NG, NI, NO, NZ, OM, PE, PG, PH, PL, PT, QA, RO, RS, RU, RW, SC, SD, SE, SG, SK, SL, SM, ST, SV, SY, TH, TJ, TM, TN, TR, TT, TZ, UA, UG, US, UZ, VC, VN, ZA, ZM, ZW.

(84) Designated States (unless otherwise indicated, for every kind of regional protection available): ARIPO (BW, GH, GM, KE, LR, LS, MW, MZ, NA, RW, SD, SL, SZ, TZ, UG, ZM, ZW), Eurasian (AM, AZ, BY, KG, KZ, MD, RU, TJ, TM), European (AL, AT, BE, BG, CH, CY, CZ, DE, DK, EE, ES, FI, FR, GB, GR, HR, HU, IE, IS, IT, LT, LU, LV, MC, MK, MT, NL, NO, PL, PT, RO, RS, SE, SI, SK, SM, TR), OAPI (BF, BJ, CF, CG, CI, CM, GA, GN, GQ, GW, ML, MR, NE, SN, TD, TG).

Published:

- with international search report (Art. 21(3))
- before the expiration of the time limit for amending the claims and to be republished in the event of receipt of amendments (Rule 48.2(h))

(54) Title: SURFACE SCATTERING ANTENNAS

FIG. 1

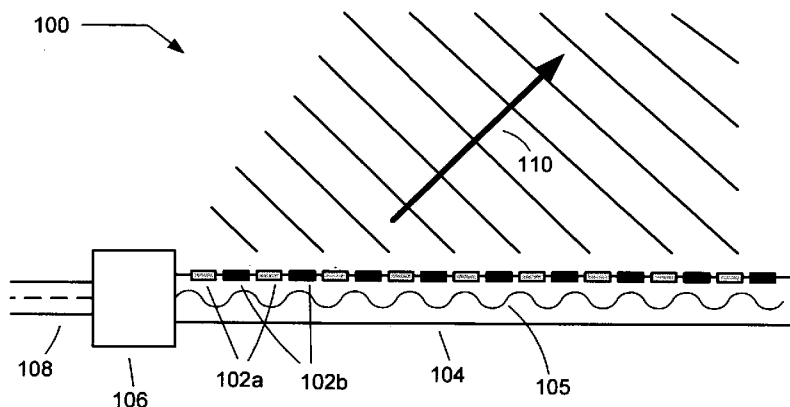

(57) Abstract: Surface scattering antennas provide adjustable radiation fields by adjustably coupling scattering elements along a wave-propagating structure. In some approaches, the scattering elements are complementary metamaterial elements. In some approaches, the scattering elements are made adjustable by disposing an electrically adjustable material, such as a liquid crystal, in proximity to the scattering elements. Methods and systems provide control and adjustment of surface scattering antennas for various applications.

WO 2012/050614 A1

## Surface Scattering Antennas

### CROSS-REFERENCE TO RELATED APPLICATIONS

The present application is related to and claims the benefit of the earliest  
5 available effective filing date(s) from the following listed application(s) (the “Related  
Applications”) (e.g., claims earliest available priority dates for other than provisional  
patent applications or claims benefits under 35 USC § 119(e) for provisional patent  
applications, for any and all parent, grandparent, great-grandparent, etc. applications  
of the Related Application(s)). All subject matter of the Related Applications and of  
10 any and all parent, grandparent, great-grandparent, etc. applications of the Related  
Applications, including any priority claims, is incorporated herein by reference to the  
extent such subject matter is not inconsistent herewith.

#### Related Applications:

For purposes of the USPTO extra-statutory requirements, the present  
15 application constitutes a continuation-in-part of United States Patent  
Application No. **61/455,171**, entitled **SURFACE SCATTERING  
ANTENNAS**, naming **NATHAN KUNDTZ ET AL.** as inventors, filed **15,  
OCTOBER, 2010**, which is currently co-pending or is an application of  
which a currently co-pending application is entitled to the benefit of the filing  
20 date.

The United States Patent Office (USPTO) has published a notice to the effect  
that the USPTO’s computer programs require that patent applicants reference both a  
serial number and indicate whether an application is a continuation, continuation-in-  
part, or divisional of a parent application. Stephen G. Kunin, *Benefit of Prior-Filed*  
25 *Application*, USPTO Official Gazette March 18, 2003. The present Applicant Entity  
(hereinafter “Applicant”) has provided above a specific reference to the application(s)  
*from which priority is being claimed* as recited by statute. Applicant understands that

the statute is unambiguous in its specific reference language and does not require either a serial number or any characterization, such as “continuation” or “continuation-in-part,” for claiming priority to U.S. patent applications. Notwithstanding the foregoing, Applicant understands that the USPTO’s computer programs have certain data entry requirements, and hence Applicant has provided designation(s) of a relationship between the present application and its parent application(s) as set forth above, but expressly points out that such designation(s) are not to be construed in any way as any type of commentary and/or admission as to whether or not the present application contains any new matter in addition to the matter of its parent application(s).

## **BRIEF DESCRIPTION OF THE FIGURES**

**FIG. 1** is a schematic depiction of a surface scattering antenna.

**FIGS. 2A** and **2B** respectively depict an exemplary adjustment pattern and corresponding beam pattern for a surface scattering antenna.

**FIGS. 3A** and **3B** respectively depict another exemplary adjustment pattern and corresponding beam pattern for a surface scattering antenna.

**FIGS. 4A** and **4B** respectively depict another exemplary adjustment pattern and corresponding field pattern for a surface scattering antenna.

**FIGS. 5** and **6** depict a unit cell of a surface scattering antenna.

**FIG. 7** depicts examples of metamaterial elements.

**FIG. 8** depicts a microstrip embodiment of a surface scattering antenna.

**FIG. 9** depicts a coplanar waveguide embodiment of a surface scattering antenna.

**FIGS. 10** and **11** depict a closed waveguide embodiments of a surface scattering antenna.

**FIG. 12** depicts a surface scattering antenna with direct addressing of the scattering elements.

**FIG. 13** depicts a surface scattering antenna with matrix addressing of the scattering elements.

**FIG. 14** depicts a system block diagram.

**FIGS. 15 and 16** depict flow diagrams.

## **DETAILED DESCRIPTION**

In the following detailed description, reference is made to the accompanying drawings, which form a part hereof. In the drawings, similar symbols typically  
5 identify similar components, unless context dictates otherwise. The illustrative embodiments described in the detailed description, drawings, and claims are not meant to be limiting. Other embodiments may be utilized, and other changes may be made, without departing from the spirit or scope of the subject matter presented here.

A schematic illustration of a surface scattering antenna is depicted in **FIG. 1**.  
10 The surface scattering antenna **100** includes a plurality of scattering elements **102a**, **102b** that are distributed along a wave-propagating structure **104**. The wave propagating structure **104** may be a microstrip, a coplanar waveguide, a parallel plate waveguide, a dielectric slab, a closed or tubular waveguide, or any other structure capable of supporting the propagation of a guided wave or surface wave **105** along or  
15 within the structure. The wavy line **105** is a symbolic depiction of the guided wave or surface wave, and this symbolic depiction is not intended to indicate an actual wavelength or amplitude of the guided wave or surface wave; moreover, while the wavy line **105** is depicted as within the wave-propagating structure **104** (e.g. as for a guided wave in a metallic waveguide), for a surface wave the wave may be  
20 substantially localized outside the wave-propagating structure (e.g. as for a TM mode on a single wire transmission line or a “spoof plasmon” on an artificial impedance surface). The scattering elements **102a**, **102b** may include metamaterial elements that are embedded within, positioned on a surface of, or positioned within an evanescent proximity of, the wave-propagation structure **104**; for example, the scattering  
25 elements can include complementary metamaterial elements such as those presented in D. R. Smith et al, “Metamaterials for surfaces and waveguides,” U.S. Patent Application Publication No. 2010/0156573, which is herein incorporated by reference.

The surface scattering antenna also includes at least one feed connector **106**  
30 that is configured to couple the wave-propagation structure **104** to a feed structure

108. The feed structure **108** (schematically depicted as a coaxial cable) may be a transmission line, a waveguide, or any other structure capable of providing an electromagnetic signal that may be launched, via the feed connector **106**, into a guided wave or surface wave **105** of the wave-propagating structure **104**. The feed  
5 connector **106** may be, for example, a coaxial-to-microstrip connector (e.g. an SMA-to-PCB adapter), a coaxial-to-waveguide connector, a mode-matched transition section, etc.. While **FIG. 1** depicts the feed connector in an “end-launch” configuration, whereby the guided wave or surface wave **105** may be launched from a peripheral region of the wave-propagating structure (e.g. from an end of a microstrip  
10 or from an edge of a parallel plate waveguide), in other embodiments the feed structure may be attached to a non-peripheral portion of the wave-propagating structure, whereby the guided wave or surface wave **105** may be launched from that non-peripheral portion of the wave-propagating structure (e.g. from a midpoint of a microstrip or through a hole drilled in a top or bottom plate of a parallel plate  
15 waveguide); and yet other embodiments may provide a plurality of feed connectors attached to the wave-propagating structure at a plurality of locations (peripheral and/or non-peripheral).

The scattering elements **102a**, **102b** are adjustable scattering elements having electromagnetic properties that are adjustable in response to one or more external  
20 inputs. Various embodiments of adjustable scattering elements are described, for example, in D. R. Smith et al, previously cited, and further in this disclosure. Adjustable scattering elements can include elements that are adjustable in response to voltage inputs (e.g. bias voltages for active elements (such as varactors, transistors, diodes) or for elements that incorporate tunable dielectric materials (such as  
25 ferroelectrics)), current inputs (e.g. direct injection of charge carriers into active elements), optical inputs (e.g. illumination of a photoactive material), field inputs (e.g. magnetic fields for elements that include nonlinear magnetic materials), mechanical inputs (e.g. MEMS, actuators, hydraulics), etc. In the schematic example of **FIG. 1**, scattering elements that have been adjusted to a first state having first  
30 electromagnetic properties are depicted as the first elements **102a**, while scattering elements that have been adjusted to a second state having second electromagnetic

properties are depicted as the second elements **102b**. The depiction of scattering elements having first and second states corresponding to first and second electromagnetic properties is not intended to be limiting: embodiments may provide scattering elements that are discretely adjustable to select from a discrete plurality of states corresponding to a discrete plurality of different electromagnetic properties, or  
5 continuously adjustable to select from a continuum of states corresponding to a continuum of different electromagnetic properties. Moreover, the particular pattern of adjustment that is depicted in **FIG. 1** (i.e. the alternating arrangement of elements **102a** and **102b**) is only an exemplary configuration and is not intended to be limiting.

10 In the example of **FIG. 1**, the scattering elements **102a**, **102b** have first and second couplings to the guided wave or surface wave **105** that are functions of the first and second electromagnetic properties, respectively. For example, the first and second couplings may be first and second polarizabilities of the scattering elements at the frequency or frequency band of the guided wave or surface wave. In one  
15 approach the first coupling is a substantially nonzero coupling whereas the second coupling is a substantially zero coupling. In another approach both couplings are substantially nonzero but the first coupling is substantially greater than (or less than) than the second coupling. On account of the first and second couplings, the first and second scattering elements **102a**, **102b** are responsive to the guided wave or surface  
20 wave **105** to produce a plurality of scattered electromagnetic waves having amplitudes that are functions of (e.g. are proportional to) the respective first and second couplings. A superposition of the scattered electromagnetic waves comprises an electromagnetic wave that is depicted, in this example, as a plane wave **110** that radiates from the surface scattering antenna **100**.

25 The emergence of the plane wave may be understood by regarding the particular pattern of adjustment of the scattering elements (e.g. an alternating arrangement of the first and second scattering elements in **FIG. 1**) as a pattern that defines a grating that scatters the guided wave or surface wave **105** to produce the plane wave **110**. Because this pattern is adjustable, some embodiments of the surface  
30 scattering antenna may provide adjustable gratings or, more generally, holograms, where the pattern of adjustment of the scattering elements may be selected according

to principles of holography. Suppose, for example, that the guided wave or surface wave may be represented by a complex scalar input wave  $\Psi_{in}$  that is a function of position along the wave-propagating structure **104**, and it is desired that the surface scattering antenna produce an output wave that may be represented by another

5 complex scalar wave  $\Psi_{out}$ . Then a pattern of adjustment of the scattering elements may be selected that corresponds to an interference pattern of the input and output waves along the wave-propagating structure. For example, the scattering elements may be adjusted to provide couplings to the guided wave or surface wave that are functions of (e.g. are proportional to, or step-functions of) an interference term given

10 by  $\text{Re}[\Psi_{out} \Psi_{in}^*]$ . In this way, embodiments of the surface scattering antenna may be adjusted to provide arbitrary antenna radiation patterns by identifying an output wave  $\Psi_{out}$  corresponding to a selected beam pattern, and then adjusting the scattering elements accordingly as above. Embodiments of the surface scattering antenna may therefore be adjusted to provide, for example, a selected beam direction (e.g. beam

15 steering), a selected beam width or shape (e.g. a fan or pencil beam having a broad or narrow beamwidth), a selected arrangement of nulls (e.g. null steering), a selected arrangement of multiple beams, a selected polarization state (e.g. linear, circular, or elliptical polarization), a selected overall phase, or any combination thereof. Alternatively or additionally, embodiments of the surface scattering antenna may be

20 adjusted to provide a selected near field radiation profile, e.g. to provide near-field focusing and/or near-field nulls.

Because the spatial resolution of the interference pattern is limited by the spatial resolution of the scattering elements, the scattering elements may be arranged along the wave-propagating structure with inter-element spacings that are much less

25 than a free-space wavelength corresponding to an operating frequency of the device (for example, less than one-fourth of one-fifth of this free-space wavelength). In some approaches, the operating frequency is a microwave frequency, selected from frequency bands such as Ka, Ku, and Q, corresponding to centimeter-scale free-space wavelengths. This length scale admits the fabrication of scattering elements using

30 conventional printed circuit board technologies, as described below.

In some approaches, the surface scattering antenna includes a substantially one-dimensional wave-propagating structure **104** having a substantially one-dimensional arrangement of scattering elements, and the pattern of adjustment of this one-dimensional arrangement may provide, for example, a selected antenna radiation profile as a function of zenith angle (i.e. relative to a zenith direction that is parallel to the one-dimensional wave-propagating structure). In other approaches, the surface scattering antenna includes a substantially two-dimensional wave-propagating structure **104** having a substantially two-dimensional arrangement of scattering elements, and the pattern of adjustment of this two-dimensional arrangement may provide, for example, a selected antenna radiation profile as a function of both zenith and azimuth angles (i.e. relative to a zenith direction that is perpendicular to the two-dimensional wave-propagating structure). Exemplary adjustment patterns and beam patterns for a surface scattering antenna that includes a two-dimensional array of scattering elements distributed on a planar rectangular wave-propagating structure are depicted in **FIGS. 2A – 4B**. In these exemplary embodiments, the planar rectangular wave-propagating structure includes a monopole antenna feed that is positioned at the geometric center of the structure. **FIG. 2A** presents an adjustment pattern that corresponds to a narrow beam having a selected zenith and azimuth as depicted by the beam pattern diagram of **FIG. 2B**. **FIG. 3A** presents an adjustment pattern that corresponds to a dual-beam far field pattern as depicted by the beam pattern diagram of **FIG. 3B**. **FIG. 4A** presents an adjustment pattern that provides near-field focusing as depicted by the field intensity map of **FIG. 4B** (which depicts the field intensity along a plane perpendicular to and bisecting the long dimension of the rectangular wave-propagating structure).

In some approaches, the wave-propagating structure is a modular wave-propagating structure and a plurality of modular wave-propagating structures may be assembled to compose a modular surface scattering antenna. For example, a plurality of substantially one-dimensional wave-propagating structures may be arranged, for example, in an interdigital fashion to produce an effective two-dimensional arrangement of scattering elements. The interdigital arrangement may comprise, for example, a series of adjacent linear structures (i.e. a set of parallel straight lines) or a



series of adjacent curved structures (i.e. a set of successively offset curves such as sinusoids) that substantially fills a two-dimensional surface area. As another example, a plurality of substantially two-dimensional wave-propagating structures (each of which may itself comprise a series of one-dimensional structures, as above) may be assembled to produce a larger aperture having a larger number of scattering elements; and/or the plurality of substantially two-dimensional wave-propagating structures may be assembled as a three-dimensional structure (e.g. forming an A-frame structure, a pyramidal structure, or other multi-faceted structure). In these modular assemblies, each of the plurality of modular wave-propagating structures may have its own feed connector(s) **106**, and/or the modular wave-propagating structures may be configured to couple a guided wave or surface wave of a first modular wave-propagating structure into a guided wave or surface wave of a second modular wave-propagating structure by virtue of a connection between the two structures.

In some applications of the modular approach, the number of modules to be assembled may be selected to achieve an aperture size providing a desired telecommunications data capacity and/or quality of service, and/or a three-dimensional arrangement of the modules may be selected to reduce potential scan loss. Thus, for example, the modular assembly could comprise several modules mounted at various locations/orientations flush to the surface of a vehicle such as an aircraft, spacecraft, watercraft, ground vehicle, etc. (the modules need not be contiguous). In these and other approaches, the wave-propagating structure may have a substantially non-linear or substantially non-planar shape whereby to conform to a particular geometry, therefore providing a conformal surface scattering antenna (conforming, for example, to the curved surface of a vehicle).

More generally, a surface scattering antenna is a reconfigurable antenna that may be reconfigured by selecting a pattern of adjustment of the scattering elements so that a corresponding scattering of the guided wave or surface wave produces a desired output wave. Suppose, for example, that the surface scattering antenna includes a plurality of scattering elements distributed at positions  $\{\mathbf{r}_j\}$  along a wave-propagating structure **104** as in **FIG. 1** (or along multiple wave-propagating structures, for a

modular embodiment) and having a respective plurality of adjustable couplings  $\{\alpha_j\}$  to the guided wave or surface wave **105**. The guided wave or surface wave **105**, as it propagates along or within the (one or more) wave-propagating structure(s), presents a wave amplitude  $A_j$  and phase  $\varphi_j$  to the  $j$ th scattering element; subsequently, an  
 5 output wave is generated as a superposition of waves scattered from the plurality of scattering elements:

$$\mathbf{E}(\theta, \phi) = \sum_j \mathbf{R}_j(\theta, \phi) \alpha_j A_j e^{i\varphi_j} e^{i(\mathbf{k}(\theta, \phi) \cdot \mathbf{r}_j)}, \quad (1)$$

where  $\mathbf{E}(\theta, \phi)$  represents the electric field component of the output wave on a far-field radiation sphere,  $\mathbf{R}_j(\theta, \phi)$  represents a (normalized) electric field pattern for the  
 10 scattered wave that is generated by the  $j$ th scattering element in response to an excitation caused by the coupling  $\alpha_j$ , and  $\mathbf{k}(\theta, \phi)$  represents a wave vector of magnitude  $\omega/c$  that is perpendicular to the radiation sphere at  $(\theta, \phi)$ . Thus, embodiments of the surface scattering antenna may provide a reconfigurable antenna that is adjustable to produce a desired output wave  $\mathbf{E}(\theta, \phi)$  by adjusting the plurality  
 15 of couplings  $\{\alpha_j\}$  in accordance with equation (1).

The wave amplitude  $A_j$  and phase  $\varphi_j$  of the guided wave or surface wave are functions of the propagation characteristics of the wave-propagating structure **104**. These propagation characteristics may include, for example, an effective refractive index and/or an effective wave impedance, and these effective electromagnetic  
 20 properties may be at least partially determined by the arrangement and adjustment of the scattering elements along the wave-propagating structure. In other words, the wave-propagating structure, in combination with the adjustable scattering elements, may provide an adjustable effective medium for propagation of the guided wave or surface wave, e.g. as described in D. R. Smith et al, previously cited. Therefore,  
 25 although the wave amplitude  $A_j$  and phase  $\varphi_j$  of the guided wave or surface wave may depend upon the adjustable scattering element couplings  $\{\alpha_j\}$  (i.e.

$A_i = A_i(\{\alpha_j\})$ ,  $\varphi_i = \varphi_i(\{\alpha_j\})$ ), in some embodiments these dependencies may be

substantially predicted according to an effective medium description of the wave-propagating structure.

In some approaches, the reconfigurable antenna is adjustable to provide a desired polarization state of the output wave  $\mathbf{E}(\theta, \phi)$ . Suppose, for example, that first and second subsets  $LP^{(1)}$  and  $LP^{(2)}$  of the scattering elements provide (normalized) electric field patterns  $\mathbf{R}^{(1)}(\theta, \phi)$  and  $\mathbf{R}^{(2)}(\theta, \phi)$ , respectively, that are substantially linearly polarized and substantially orthogonal (for example, the first and second subjects may be scattering elements that are perpendicularly oriented on a surface of the wave-propagating structure **104**). Then the antenna output wave  $\mathbf{E}(\theta, \phi)$  may be expressed as a sum of two linearly polarized components:

$$\mathbf{E}(\theta, \phi) = \mathbf{E}^{(1)}(\theta, \phi) + \mathbf{E}^{(2)}(\theta, \phi) = \Lambda^{(1)}\mathbf{R}^{(1)}(\theta, \phi) + \Lambda^{(2)}\mathbf{R}^{(2)}(\theta, \phi), \quad (2)$$

where

$$\Lambda^{(1,2)}(\theta, \phi) = \sum_{j \in LP^{(1,2)}} \alpha_j A_j e^{i\phi_j} e^{i(\mathbf{k}(\theta, \phi) \cdot \mathbf{r}_j)} \quad (3)$$

are the complex amplitudes of the two linearly polarized components. Accordingly, the polarization of the output wave  $\mathbf{E}(\theta, \phi)$  may be controlled by adjusting the plurality of couplings  $\{\alpha_j\}$  in accordance with equations (2)-(3), e.g. to provide an output wave with any desired polarization (e.g. linear, circular, or elliptical).

Alternatively or additionally, for embodiments in which the wave-propagating structure has a plurality of feeds (e.g. one feed for each “finger” of an interdigital arrangement of one-dimensional wave-propagating structures, as discussed above), a desired output wave  $\mathbf{E}(\theta, \phi)$  may be controlled by adjusting gains of individual amplifiers for the plurality of feeds. Adjusting a gain for a particular feed line would correspond to multiplying the  $A_j$ 's by a gain factor  $G$  for those elements  $j$  that are fed by the particular feed line. Especially, for approaches in which a first wave-propagating structure having a first feed (or a first set of such structures/feeds) is coupled to elements that are selected from  $LP^{(1)}$  and a second wave-propagating structure having a second feed (or a second set of such structures/feeds) is coupled to elements that are selected from  $LP^{(2)}$ , depolarization loss (e.g., as a beam is scanned

off-broadside) may be compensated by adjusting the relative gain(s) between the first feed(s) and the second feed(s).

As mentioned previously in the context of **FIG. 1**, in some approaches the surface scattering antenna **100** includes a wave-propagating structure **104** that may be implemented as a microstrip or a parallel plate waveguide (or a plurality of such elements); and in these approaches, the scattering elements may include complementary metamaterial elements such as those presented in D.R. Smith et al, previously cited. Turning now to **FIG. 5**, an exemplary unit cell **500** of a microstrip or parallel-plate waveguide is depicted that includes a lower conductor or ground plane **502** (made of copper or similar material), a dielectric substrate **504** (made of Duriod, FR4, or similar material), and an upper conductor **506** (made of copper or similar material) that embeds a complementary metamaterial element **510**, in this case a complementary electric LC (CELC) metamaterial element that is defined by a shaped aperture **512** that has been etched or patterned in the upper conductor (e.g. by a PCB process).

A CELC element such as that depicted in **FIG. 5** is substantially responsive to a magnetic field that is applied parallel to the plane of the CELC element and perpendicular to the CELC gap complement, i.e. in the  $\hat{x}$  direction for the orientation of **FIG. 5** (cf. T. H. Hand et al, "Characterization of complementary electric field coupled resonant surfaces," *Applied Physics Letters* **93**, 212504(2008), herein incorporated by reference). Therefore, a magnetic field component of a guided wave that propagates in the microstrip or parallel plate waveguide (being an instantiation of the guided wave or surface wave **105** of **FIG. 1**) can induce a magnetic excitation of the element **510** that may be substantially characterized as a magnetic dipole excitation oriented in  $\hat{x}$  direction, thus producing a scattered electromagnetic wave that is substantially a magnetic dipole radiation field.

Noting that the shaped aperture **512** also defines a conductor island **514** which is electrically disconnected from the upper conductor **506**, in some approaches the scattering element can be made adjustable by providing an adjustable material within and/or proximate to the shaped aperture **512** and subsequently applying a bias voltage between the conductor island **514** and the upper conductor **506**. For example, as

shown in **FIG. 5**, the unit cell may be immersed in a layer of liquid crystal material **520**. Liquid crystals have a permittivity that is a function of orientation of the molecules comprising the liquid crystal; and that orientation may be controlled by applying a bias voltage (equivalently, a bias electric field) across the liquid crystal; accordingly, liquid crystals can provide a voltage-tunable permittivity for adjustment of the electromagnetic properties of the scattering element.

The liquid crystal material **520** may be retained in proximity to the scattering elements by, for example, providing a liquid crystal containment structure on the upper surface of the wave-propagating structure. An exemplary configuration of a liquid crystal containment structure is shown in **FIG. 5**, which depicts a liquid crystal containment structure that includes a covering portion **532** and, optionally, one or more support portions or spacers **534** that provide a separation between the upper conductor **506** and the covering portion **532**. In some approaches, the liquid crystal containment structure is a machined or injection-molded plastic part having a flat surface that may be joined to the upper surface of the wave-propagating structure, the flat surface including one or more indentations (e.g. grooves or recesses) that may be overlaid on the scattering elements; and these indentations may be filled with liquid crystal by, for example, a vacuum injection process. In other approaches, the support portions **534** are spherical spacers (e.g. spherical resin particles); or walls or pillars that are formed by a photolithographic process (e.g. as described in Sato et al, "Method for manufacturing liquid crystal device with spacers formed by photolithography," U.S. Patent No. 4,874,461, herein incorporated by reference); the covering portion **532** is then affixed to the support portions **534**, followed by installation (e.g. by vacuum injection) of the liquid crystal.

For a nematic phase liquid crystal, wherein the molecular orientation may be characterized by a director field, the material may provide a larger permittivity  $\epsilon_{\parallel}$  for an electric field component that is parallel to the director and a smaller permittivity  $\epsilon_{\perp}$  for an electric field component that is perpendicular to the director. Applying a bias voltage introduces bias electric field lines that span the shaped aperture and the director tends to align parallel to these electric field lines (with the degree of alignment increasing with bias voltage). Because these bias electric field lines are

substantially parallel to the electric field lines that are produced during a scattering excitation of the scattering element, the permittivity that is seen by the biased scattering element correspondingly tends towards  $\epsilon_0$  (i.e. with increasing bias voltage). On the other hand, the permittivity that is seen by the unbiased scattering element may depend on the unbiased configuration of the liquid crystal. When the unbiased liquid crystal is maximally disordered (i.e. with randomly oriented micro-domains), the unbiased scattering element may see an averaged permittivity  $\epsilon_{ave} \approx (\epsilon_0 + \epsilon_{\perp}) / 2$ . When the unbiased liquid crystal is maximally aligned perpendicular to the bias electric field lines (i.e. prior to the application of the bias electric field), the unbiased scattering element may see a permittivity as small as  $\epsilon_{\perp}$ . Accordingly, for embodiments where it is desired to achieve a greater range of tuning of the permittivity that is seen by the scattering element (corresponding to a greater range of tuning of an effective capacitance of the scattering element and therefore a greater range of tuning of a resonant frequency of the scattering element), the unit cell 500 may include positionally-dependent alignment layer(s) disposed at the top and/or bottom surface of the liquid crystal layer 510, the positionally-dependent alignment layer(s) being configured to align the liquid crystal director in a direction substantially perpendicular to the bias electric field lines that correspond an applied bias voltage. The alignment layer(s) may include, for example, polyimide layer(s) that are rubbed or otherwise patterned (e.g. by machining or photolithography) to introduce microscopic grooves that run parallel to the channels of the shaped aperture 512.

Alternatively or additionally, the unit cell may provide a first biasing that aligns the liquid crystal substantially perpendicular to the channels of the shaped aperture 512 (e.g. by introducing a bias voltage between the upper conductor 506 and the conductor island 514, as described above), and a second biasing that aligns the liquid crystal substantially parallel to the channels of the shaped aperture 512 (e.g. by introducing electrodes positioned above the upper conductor 506 at the four corners of the units cell, and applying opposite voltages to the electrodes at adjacent corners); tuning of the scattering element may then be accomplished by, for example,

alternating between the first biasing and the second biasing, or adjusting the relative strengths of the first and second biasings.

In some approaches, a sacrificial layer may be used to enhance the effect of the liquid crystal tuning by admitting a greater volume of liquid crystal within a vicinity of the shaped aperture **512**. An illustration of this approach is depicted in **FIG. 6**, which shows the unit cell **500** of **FIG. 5** in profile, with the addition of a sacrificial layer **600** (e.g. a polyimide layer) that is deposited between the dielectric substrate **504** and the upper conductor **506**. Subsequent to etching of the upper conductor **506** to define the shaped aperture **512**, a further selective etching of the sacrificial layer **600** produces cavities **602** that may then be filled with the liquid crystal **520**. In some approaches another masking layer is used (instead of or in addition to making by the upper conductor **506**) to define the pattern of selective etching of the sacrificial layer **600**.

Exemplary liquid crystals that may be deployed in various embodiments include 4-Cyano-4'-pentylbiphenyl, high birefringence eutectic LC mixtures such as LCMS-107 (LC Matter) or GT3-23001 (Merck). Some approaches may utilize dual-frequency liquid crystals. In dual-frequency liquid crystals, the director aligns substantially parallel to an applied bias field at a lower frequencies, but substantially perpendicular to an applied bias field at higher frequencies. Accordingly, for approaches that deploy these dual-frequency liquid crystals, tuning of the scattering elements may be accomplished by adjusting the frequency of the applied bias voltage signals. Other approaches may deploy polymer network liquid crystals (PNLCs) or polymer dispersed liquid crystals (PDLCs), which generally provide much shorter relaxation/switching times for the liquid crystal. An example of the former is a thermal or UV cured mixture of a polymer (such as BPA-dimethacrylate) in a nematic LC host (such as LCMS-107); cf. Y.H. Fan et al, "Fast-response and scattering-free polymer network liquid crystals for infrared light modulators," *Applied Physics Letters* **84**, 1233-35 (2004), herein incorporated by reference. An example of the latter is a porous polymer material (such as a PTFE membrane) impregnated with a nematic LC (such as LCMS-107); cf. T. Kuki et al, "Microwave variable delay line using a membrane impregnated with liquid crystal," *Microwave Symposium Digest*,

*2002 IEEE MTT-S International*, vol.1, pp.363-366 (2002), herein incorporated by reference.

Turning now to approaches for providing a bias voltage between the conductor island **514** and the upper conductor **506**, it is first noted that the upper conductor **506** extends contiguously from one unit cell to the next, so an electrical connection to the upper conductor of every unit cell may be made by a single connection to the upper conductor of the microstrip or parallel-plate waveguide of which unit cell **500** is a constituent. As for the conductor island **514**, **FIG. 5** shows an example of how a bias voltage line **530** may be attached to the conductor island. In this example, the bias voltage line **530** is attached at the center of the conductor island and extends away from the conductor island along an plane of symmetry of the scattering element; by virtue of this positioning along a plane of symmetry, electric fields that are experienced by the bias voltage line during a scattering excitation of the scattering element are substantially perpendicular to the bias voltage line and therefore do not excite currents in the bias voltage line that could disrupt or alter the scattering properties of the scattering element. The bias voltage line **530** may be installed in the unit cell by, for example, depositing an insulating layer (e.g. polyimide), etching the insulating layer at the center of the conductor island **514**, and then using a lift-off process to pattern a conducting film (e.g. a Cr/Au bilayer) that defines the bias voltage line **530**.

**FIGS. 7A-7H** depict a variety of CELC elements that may be used in accordance with various embodiments of a surface scattering antenna. These are schematic depictions of exemplary elements, not drawn to scale, and intended to be merely representative of a broad variety of possible CELC elements suitable for various embodiments. **FIG. 7A** corresponds to the element used in **FIG. 5**. **FIG. 7B** depicts an alternative CELC element that is topologically equivalent to that of **7A**, but which uses an undulating perimeter to increase the lengths of the arms of the element, thereby increasing the capacitance of the element. **FIGS. 7C** and **7D** depict a pair of element types that may be utilized to provide polarization control. When these orthogonal elements are excited by a guided wave or surface wave having a magnetic field oriented in the  $\hat{y}$  direction, this applied magnetic field produces magnetic



excitations that may be substantially characterized as magnetic dipole excitations, oriented at  $+45^\circ$  or  $-45^\circ$  relative to the  $\hat{x}$  direction for the element of **7C** or **7D**, respectively. **FIGS. 7E** and **7F** depict variants of such orthogonal CELC elements in the which the arms of the CELC element are also slanted at a  $\pm 45^\circ$  angle. These  
5 slanted designs potentially provide a purer magnetic dipole response, because all of the regions of the CELC element that give rise to the dipolar response are either oriented orthogonal to the exciting field (and therefore not excited) or at a  $45^\circ$  angle with respect to that field. Finally, **FIGS. 7E** and **7F** depict similarly slanted variants of the undulated CELC element of **FIG. 7B**.

10 While **FIG. 5** presents an example of a metamaterial element **510** that is patterned on the upper conductor **506** of a wave-propagating structure such as a microstrip, in another approach, as depicted in **FIG. 8**, the metamaterial elements are not positioned on the microstrip itself; rather, they are positioned within an evanescent proximity of (i.e. within the fringing fields of) a microstrip. Thus, **FIG. 8**  
15 depicts a microstrip configuration having a ground plane **802**, a dielectric substrate **804**, and an upper conductor **806**, with conducting strips **808** positioned along either side of the microstrip. These conducting strips **808** embed complementary metamaterial elements **810** defined by shaped apertures **812**. In this example, the complementary metamaterial elements are undulating-perimeter CELC elements such  
20 as that shown in **FIG. 7B**. As shown in **FIG. 8**, a via **840** can be used to connect a bias voltage line **830** to the conducting island **814** of each metamaterial element. As a result, this configuration can be readily implemented using a two-layer PCB process (two conducting layers with an intervening dielectric), with layer 1 providing the microstrip signal trace and metamaterial elements, and layer 2 providing the  
25 microstrip ground plane and biasing traces. The dielectric and conducting layers may be high efficiency materials such as copper-clad Rogers 5880. As before, tuning may be accomplished by disposing a layer of liquid crystal (not shown) above the metamaterial elements **810**.

In yet another approach, as depicted in **FIGS. 9A** and **9B**, the wave-  
30 propagating structure is a coplanar waveguide (CPW), and the metamaterial elements are positioned within an evanescent proximity of (i.e. within the fringing fields of) the

coplanar waveguide. Thus, **FIGS. 9A** and **9B** depict a coplanar waveguide configuration having a lower ground plane **902**, central ground planes **906** on either side of a CPW signal trace **907**, and an upper ground plane **910** that embeds complementary metamaterial elements **920** (only one is shown, but the approach positions a series of such elements along the length of the CPW). These successive conducting layers are separated by dielectric layers **904**, **908**. The coplanar waveguide may be bounded by colonnades of vias **930** that can serve to cut off higher order modes of the CPW and/or reduce crosstalk with adjacent CPWs (not shown). The CPW strip width **909** can be varied along the length of the CPW to control the couplings to the metamaterial elements **920**, e.g. to enhance aperture efficiency and/or control aperture tapering of the beam profile. The CPW gap width **911** can be adjusted to control the line impedance. As shown in **FIG. 9B**, a third dielectric layer **912** and a through-via **940** can be used to connect a bias voltage line **950** to the conducting island **922** of each metamaterial element and to a biasing pad **952** situated on the underside of the structure. Channels **924** in the third dielectric layer **912** admit the disposal of the liquid crystal (not shown) within the vicinities of the shaped apertures of the conducting element. This configuration can be implemented using a four-layer PCB process (four conducting layers with three intervening dielectric layers). These PCBs may be manufactured using lamination stages along with through, blind and buried via formation as well as electroplating and electroless plating techniques.

In still another approach, depicted in **FIGS. 10** and **11**, the wave-propagating structure is a closed, or tubular, waveguide, and the metamaterial elements are positioned along the surface of the closed waveguide. Thus, **FIG. 10** depicts a closed, or tubular, waveguide with a rectangular cross section defined by a trough **1002** and a conducting surface **1004** that embeds the metamaterial element **1010**. As the cutaway shows, a via **1020** through a dielectric layer **1022** can be used to connect a bias voltage line **1030** to the conducting island **1012** of the metamaterial element. The trough **1002** can be implemented as a piece of metal that is milled or cast to provide the “floor and walls” of the closed waveguide, and the waveguide “ceiling” can be implemented as a two-layer printed circuit board, with the top layer providing

the biasing traces **1030** and the bottom layer providing the metamaterial elements **1010**. The waveguide may be loaded with a dielectric **1040** (such as PTFE) having a smaller trough **1050** that can be filled with liquid crystal to admit tuning of the metamaterial elements.

5           In an alternative closed waveguide embodiment as depicted in **FIG. 11**, a closed waveguide with a rectangular cross section is defined by a trough **1102** and conducting surface **1104**. As the unit cell cutaway shows, the conductor surface **1104** has an iris **1106** that admits coupling between a guided wave and the resonator element **1110**. In this example, the complementary metamaterial element is an  
10 undulating-perimeter CELC element such as that shown in **FIG. 7B**. While the figure depicts a rectangular coupling iris, other shapes can be used, and the dimensions of the irises may be varied along the length of the waveguide to control the couplings to the scattering elements (e.g. to enhance aperture efficiency and/or control aperture tapering of the beam profile). A pair of vias **1120** through the dielectric layer **1122**  
15 can be used together with a short routing line **1125** to connect a bias voltage line **1130** to the conducting island **1112** of the metamaterial element. The trough **1102** can be implemented as a piece of metal that is milled or cast to provide the “floor and walls” of the closed waveguide, and the waveguide “ceiling” can be implemented as a two-layer printed circuit board, with the top layer providing the metamaterial elements  
20 **1110** (and biasing traces **1130**), and the bottom layer providing the irises **1106** (and biasing routings **1125**). The metamaterial element **1110** may be optionally bounded by colonnades of vias **1150** extending through the dielectric layer **1122** to reduce coupling or crosstalk between adjacent unit cells. As before, tuning may be accomplished by disposing a layer of liquid crystal (not shown) above the  
25 metamaterial elements **1110**.

While the waveguide embodiments of **FIGS. 10** and **11** provide waveguides having a simple rectangular cross section, in some approaches the waveguide may include one or more ridges (as in a double-ridged waveguide). Ridged waveguides can provide greater bandwidth than simple rectangular waveguides and the ridge  
30 geometries (widths/heights) can be varied along the length of the waveguide to control the couplings to the scattering elements (e.g. to enhance aperture efficiency

and/or control aperture tapering of the beam profile) and/or to provide a smooth impedance transition (e.g. from an SMA connector feed).

In various approaches, the bias voltage lines may be directly addressed, e.g. by extending a bias voltage line for each scattering element to a pad structure for connection to antenna control circuitry, or matrix addressed, e.g. by providing each scattering element with a voltage bias circuit that is addressable by row and column. **FIG. 12** depicts a example of a configuration that provides direct addressing for an arrangement of scattering elements **1200** on the surface of a microstrip **1202**, in which a plurality of bias voltage lines **1204** are run along the length of the microstrip to deliver individual bias voltages to the scattering elements (alternatively, the bias voltage lines **1204** could be run perpendicular to the microstrip and extended to pads or vias along the length of the microstrip). (The figure also shows an example of how the scattering elements may be arranged having perpendicular orientations, e.g. to provide polarization control; in this arrangement, a guided wave that propagates along the microstrip has a magnetic field that is substantially oriented in the  $\hat{y}$  direction and may therefore be coupled to both orientations of the scattering elements, which produce magnetic excitations that may be substantially characterized as magnetic dipole excitations oriented at  $\pm 45^\circ$  relative to the  $\hat{x}$  direction). **FIG. 13** depicts an example of a configuration that provides matrix addressing for an arrangement of scattering elements **1300** (e.g. on the surface of a parallel-plate waveguide), where each scattering element is connected by a bias voltage line **1302** to a biasing circuit **1304** addressable by row inputs **1306** and column inputs **1308** (note that each row input and/or column input may include one or more signals, e.g. each row or column may be addressed by a single wire or a set of parallel wires dedicated to that row or column). Each biasing circuit may contain, for example, a switching device (e.g. a transistor), a storage device (e.g. a capacitor), and/or additional circuitry such as logic/multiplexing circuitry, digital-to-analog conversion circuitry, etc. This circuitry may be readily fabricated using monolithic integration, e.g. using a thin-film transistor (TFT) process, or as a hybrid assembly of integrated circuits that are mounted on the wave-propagating structure, e.g. using surface mount technology (SMT). In some approaches, the bias voltages may be adjusted by adjusting the

amplitude of an AC bias signal. In other approaches, the bias voltages may be adjusted by applying pulse width modulation to an AC signal.

With reference now to **FIG. 14**, an illustrative embodiment is depicted as a system block diagram. The system **1400** include a communications unit **1410**  
5 coupled by one or more feeds **1412** to an antenna unit **1420**. The communications unit **1410** might include, for example, a mobile broadband satellite transceiver, or a transmitter, receiver, or transceiver module for a radio or microwave communications system, and may incorporate data multiplexing/demultiplexing circuitry, encoder/decoder circuitry, modulator/demodulator circuitry, frequency  
10 upconverters/downconverters, filters, amplifiers, diplexes, etc. The antenna unit includes at least one surface scattering antenna, which may configured to transmit, receive, or both; and in some approaches the antenna unit **1420** may comprise multiple surface scattering antennas, e.g. first and second surface scattering antennas respectively configured to transmit and receive. For embodiments having a surface  
15 scattering antenna with multiple feeds, the communications unit may include MIMO circuitry. The system **1400** also includes an antenna controller **1430** configured to provide control input(s) **1432** that determine the configuration of the antenna. For example, the control inputs(s) may include inputs for each of the scattering elements (e.g. for a direct addressing configuration such as depicted in **FIG. 12**), row and  
20 column inputs (e.g. for a matrix addressing configuration such as that depicted in **FIG. 13**), adjustable gains for the antenna feeds, etc.

In some approaches, the antenna controller **1430** includes circuitry configured to provide control input(s) **1432** that correspond to a selected or desired antenna radiation pattern. For example, the antenna controller **1430** may store a set of  
25 configurations of the surface scattering antenna, e.g. as a lookup table that maps a set of desired antenna radiation patterns (corresponding to various beam directions, beams widths, polarization states, etc. as discussed earlier in this disclosure) to a corresponding set of values for the control input(s) **1432**. This lookup table may be previously computed, e.g. by performing full-wave simulations of the antenna for a  
30 range of values of the control input(s) or by placing the antenna in a test environment and measuring the antenna radiation patterns corresponding to a range of values of

the control input(s). In some approaches the antenna controller may be configured to use this lookup table to calculate the control input(s) according to a regression analysis; for example, by interpolating values for the control input(s) between two antenna radiation patterns that are stored in the lookup table (e.g. to allow continuous beam steering when the lookup table only includes discrete increments of a beam steering angle). The antenna controller **1430** may alternatively be configured to dynamically calculate the control input(s) **1432** corresponding to a selected or desired antenna radiation pattern, e.g. by computing a holographic pattern corresponding to an interference term  $\text{Re}[\Psi_{\text{out}} \Psi_{\text{in}}^*]$  (as discussed earlier in this disclosure), or by computing the couplings  $\{\alpha_j\}$  (corresponding to values of the control input(s)) that provide the selected or desired antenna radiation pattern in accordance with equation (1) presented earlier in this disclosure.

In some approaches the antenna unit **1420** optionally includes a sensor unit **1422** having sensor components that detect environmental conditions of the antenna (such as its position, orientation, temperature, mechanical deformation, etc.). The sensor components can include one or more GPS devices, gyroscopes, thermometers, strain gauges, etc., and the sensor unit may be coupled to the antenna controller to provide sensor data **1424** so that the control input(s) **1432** may be adjusted to compensate for translation or rotation of the antenna (e.g. if it is mounted on a mobile platform such as an aircraft) or for temperature drift, mechanical deformation, etc.

In some approaches the communications unit may provide feedback signal(s) **1434** to the antenna controller for feedback adjustment of the control input(s). For example, the communications unit may provide a bit error rate signal and the antenna controller may include feedback circuitry (e.g. DSP circuitry) that adjusts the antenna configuration to reduce the channel noise. Alternatively or additionally, for pointing or steering applications the communications unit may provide a beacon signal (e.g. from a satellite beacon) and the antenna controller may include feedback circuitry (e.g. pointing lock DSP circuitry for a mobile broadband satellite transceiver).

An illustrative embodiment is depicted as a process flow diagram in **FIG. 15**. Flow **1500** includes operation **1510**—selecting a first antenna radiation pattern for a surface scattering antenna that is adjustable responsive to one or more control inputs.

For example, an antenna radiation pattern may be selected that directs a primary beam of the radiation pattern at the location of a telecommunications satellite, a telecommunications base station, or a telecommunications mobile platform. Alternatively or additionally, an antenna radiation pattern may be selected to place

5 nulls of the radiation pattern at desired locations, e.g. for secure communications or to remove a noise source. Alternatively or additionally, an antenna radiation pattern may be selected to provide a desired polarization state, such as circular polarization (e.g. for Ka-band satellite communications) or linear polarization (e.g. for Ku-band satellite communications). Flow **1500** includes operation **1520**—determining first

10 values of the one or more control inputs corresponding to the first selected antenna radiation pattern. For example, in the system of **FIG. 14**, the antenna controller **1430** can include circuitry configured to determine values of the control inputs by using a lookup table, or by computing a hologram corresponding to the desired antenna radiation pattern. Flow **1500** optionally includes operation **1530**— providing the first

15 values of the one or more control inputs for the surface scattering antenna. For example, the antenna controller **1430** can apply bias voltages to the various scattering elements, and/or the antenna controller **1430** can adjust the gains of antenna feeds. Flow **1500** optionally includes operation **1540**—selecting a second antenna radiation pattern different from the first antenna radiation pattern. Again this can include

20 selecting, for example, a second beam direction or a second placement of nulls. In one application of this approach, a satellite communications terminal can switch between multiple satellites, e.g. to optimize capacity during peak loads, to switch to another satellite that may have entered service, or to switch from a primary satellite that has failed or is off-line. Flow **1500** optionally includes operation **1550**—

25 determining second values of the one or more control inputs corresponding to the second selected antenna radiation pattern. Again this can include, for example, using a lookup table or computing a holographic pattern. Flow **1500** optionally includes operation **1560**—providing the second values of the one or more control inputs for the surface scattering antenna. Again this can include, for example, applying bias

30 voltages and/or adjusting feed gains.

Another illustrative embodiment is depicted as a process flow diagram in **FIG. 16**. Flow **1600** includes operation **1610**—identifying a first target for a first surface scattering antenna, the first surface scattering antenna having a first adjustable radiation pattern responsive to one or more first control inputs. This first target could be, for example, a telecommunications satellite, a telecommunications base station, or a telecommunications mobile platform. Flow **1600** includes operation **1620**—repeatedly adjusting the one or more first control inputs to provide a substantially continuous variation of the first adjustable radiation pattern responsive to a first relative motion between the first target and the first surface scattering antenna. For example, in the system of **FIG. 14**, the antenna controller **1430** can include circuitry configured to steer a radiation pattern of the surface scattering antenna, e.g. to track the motion of a non-geostationary satellite, to maintain pointing lock with a geostationary satellite from a mobile platform (such as an airplane or other vehicle), or to maintain pointing lock when both the target and the antenna are moving. Flow **1600** optionally includes operation **1630**—identifying a second target for a second surface scattering antenna, the second surface scattering antenna having a second adjustable radiation pattern responsive to one or more second control inputs; and flow **1600** optionally includes operation **1640**—repeatedly adjusting the one or more second control inputs to provide a substantially continuous variation of the second adjustable radiation pattern responsive to a relative motion between the second target and the second surface scattering antenna. For example, some applications may deploy both a primary antenna unit, tracking a first object (such as a first non-geostationary satellite), and a secondary or auxiliary antenna unit, tracking a second object (such as a second non-geostationary satellite). In some approaches the auxiliary antenna unit may include a smaller-aperture antenna (tx and/or rx) used primarily used to track the location of the secondary object (and optionally to secure a link to the secondary object at a reduced quality-of-service (QoS)). Flow **1600** optionally includes operation **1650**— adjusting the one or more first control inputs to place the second target substantially within the primary beam of the first adjustable radiation pattern. For example, in an application in which the first and second antennas are components of a satellite communications terminal that interacts with a



constellation of non-geostationary satellites, the first or primary antenna may track a first member of the satellite constellation until the first member approaches the horizon (or the first antenna suffers appreciable scan loss), at which time a “handoff” is accomplished by switching the first antenna to track the second member of the satellite constellation (which was being tracked by the second or auxiliary antenna). Flow 1600 optionally includes operation 1660— identifying a new target for a second surface scattering antenna different from the first and second targets; and flow 1600 optionally includes operation 1670— adjusting the one or more second control inputs to place the new target substantially within the primary beam of the second adjustable radiation pattern. For example, after the “handoff,” the secondary or auxiliary antenna can initiate a link with a third member of the satellite constellation (e.g. as it rises above the horizon).

The foregoing detailed description has set forth various embodiments of the devices and/or processes via the use of block diagrams, flowcharts, and/or examples. Insofar as such block diagrams, flowcharts, and/or examples contain one or more functions and/or operations, it will be understood by those within the art that each function and/or operation within such block diagrams, flowcharts, or examples can be implemented, individually and/or collectively, by a wide range of hardware, software, firmware, or virtually any combination thereof. In one embodiment, several portions of the subject matter described herein may be implemented via Application Specific Integrated Circuits (ASICs), Field Programmable Gate Arrays (FPGAs), digital signal processors (DSPs), or other integrated formats. However, those skilled in the art will recognize that some aspects of the embodiments disclosed herein, in whole or in part, can be equivalently implemented in integrated circuits, as one or more computer programs running on one or more computers (e.g., as one or more programs running on one or more computer systems), as one or more programs running on one or more processors (e.g., as one or more programs running on one or more microprocessors), as firmware, or as virtually any combination thereof, and that designing the circuitry and/or writing the code for the software and or firmware would be well within the skill of one of skill in the art in light of this disclosure. In addition, those skilled in the art will appreciate that the mechanisms of the subject matter described herein are

capable of being distributed as a program product in a variety of forms, and that an illustrative embodiment of the subject matter described herein applies regardless of the particular type of signal bearing medium used to actually carry out the distribution. Examples of a signal bearing medium include, but are not limited to, the following: a recordable type medium such as a floppy disk, a hard disk drive, a Compact Disc (CD), a Digital Video Disk (DVD), a digital tape, a computer memory, etc.; and a transmission type medium such as a digital and/or an analog communication medium (e.g., a fiber optic cable, a waveguide, a wired communications link, a wireless communication link, etc.).

10 In a general sense, those skilled in the art will recognize that the various aspects described herein which can be implemented, individually and/or collectively, by a wide range of hardware, software, firmware, or any combination thereof can be viewed as being composed of various types of "electrical circuitry." Consequently, as used herein "electrical circuitry" includes, but is not limited to, electrical circuitry having at least one discrete electrical circuit, electrical circuitry having at least one integrated circuit, electrical circuitry having at least one application specific integrated circuit, electrical circuitry forming a general purpose computing device configured by a computer program (e.g., a general purpose computer configured by a computer program which at least partially carries out processes and/or devices described herein, or a microprocessor configured by a computer program which at least partially carries out processes and/or devices described herein), electrical circuitry forming a memory device (e.g., forms of random access memory), and/or electrical circuitry forming a communications device (e.g., a modem, communications switch, or optical-electrical equipment). Those having skill in the art will recognize that the subject matter described herein may be implemented in an analog or digital fashion or some combination thereof.

All of the above U.S. patents, U.S. patent application publications, U.S. patent applications, foreign patents, foreign patent applications and non-patent publications referred to in this specification and/or listed in any Application Data Sheet, are incorporated herein by reference, to the extent not inconsistent herewith.

One skilled in the art will recognize that the herein described components (e.g., steps), devices, and objects and the discussion accompanying them are used as examples for the sake of conceptual clarity and that various configuration modifications are within the skill of those in the art. Consequently, as used herein, the specific exemplars set forth and the accompanying discussion are intended to be representative of their more general classes. In general, use of any specific exemplar herein is also intended to be representative of its class, and the non-inclusion of such specific components (e.g., steps), devices, and objects herein should not be taken as indicating that limitation is desired.

10 With respect to the use of substantially any plural and/or singular terms herein, those having skill in the art can translate from the plural to the singular and/or from the singular to the plural as is appropriate to the context and/or application. The various singular/plural permutations are not expressly set forth herein for sake of clarity.

15 While particular aspects of the present subject matter described herein have been shown and described, it will be apparent to those skilled in the art that, based upon the teachings herein, changes and modifications may be made without departing from the subject matter described herein and its broader aspects and, therefore, the appended claims are to encompass within their scope all such changes and  
20 modifications as are within the true spirit and scope of the subject matter described herein. Furthermore, it is to be understood that the invention is defined by the appended claims. It will be understood by those within the art that, in general, terms used herein, and especially in the appended claims (e.g., bodies of the appended claims) are generally intended as "open" terms (e.g., the term "including" should be  
25 interpreted as "including but not limited to," the term "having" should be interpreted as "having at least," the term "includes" should be interpreted as "includes but is not limited to," etc.). It will be further understood by those within the art that if a specific number of an introduced claim recitation is intended, such an intent will be explicitly recited in the claim, and in the absence of such recitation no such intent is  
30 present. For example, as an aid to understanding, the following appended claims may contain usage of the introductory phrases "at least one" and "one or more" to

introduce claim recitations. However, the use of such phrases should not be construed to imply that the introduction of a claim recitation by the indefinite articles "a" or "an" limits any particular claim containing such introduced claim recitation to inventions containing only one such recitation, even when the same claim includes the introductory phrases "one or more" or "at least one" and indefinite articles such as "a" or "an" (e.g., "a" and/or "an" should typically be interpreted to mean "at least one" or "one or more"); the same holds true for the use of definite articles used to introduce claim recitations. In addition, even if a specific number of an introduced claim recitation *is* explicitly recited, those skilled in the art will recognize that such recitation should typically be interpreted to mean *at least* the recited number (e.g., the bare recitation of "two recitations," without other modifiers, typically means *at least* two recitations, or *two or more* recitations). Furthermore, in those instances where a convention analogous to "at least one of A, B, and C, etc." is used, in general such a construction is intended in the sense one having skill in the art would understand the convention (e.g., "a system having at least one of A, B, and C" would include but not be limited to systems that have A alone, B alone, C alone, A and B together, A and C together, B and C together, and/or A, B, and C together, etc.). In those instances where a convention analogous to "at least one of A, B, or C, etc." is used, in general such a construction is intended in the sense one having skill in the art would understand the convention (e.g., "a system having at least one of A, B, or C" would include but not be limited to systems that have A alone, B alone, C alone, A and B together, A and C together, B and C together, and/or A, B, and C together, etc.). It will be further understood by those within the art that virtually any disjunctive word and/or phrase presenting two or more alternative terms, whether in the description, claims, or drawings, should be understood to contemplate the possibilities of including one of the terms, either of the terms, or both terms. For example, the phrase "A or B" will be understood to include the possibilities of "A" or "B" or "A and B."

With respect to the appended claims, those skilled in the art will appreciate that recited operations therein may generally be performed in any order. Examples of such alternate orderings may include overlapping, interleaved, interrupted, reordered, incremental, preparatory, supplemental, simultaneous, reverse, or other variant

orderings, unless context dictates otherwise. With respect to context, even terms like “responsive to,” “related to,” or other past-tense adjectives are generally not intended to exclude such variants, unless context dictates otherwise.

5 While various aspects and embodiments have been disclosed herein, other aspects and embodiments will be apparent to those skilled in the art. The various aspects and embodiments disclosed herein are for purposes of illustration and are not intended to be limiting, with the true scope and spirit being indicated by the following claims.

What is claimed is:

## CLAIMS

1. An antenna, comprising:  
a wave-propagating structure; and  
a plurality of scattering elements distributed along the wave-propagating structure with inter-element spacings substantially less than a free-space wavelength corresponding to an operating frequency of the antenna, where the plurality of scattering elements have a plurality of adjustable individual electromagnetic responses to a guided wave or surface wave mode of the wave-propagating structure, and the plurality of adjustable individual electromagnetic responses provide an adjustable radiation field of the antenna.
2. The antenna of claim 1, wherein the plurality of scattering elements is a plurality of substantially identical scattering elements.
3. The antenna of claim 1, wherein the plurality of adjustable individual electromagnetic responses provides an effective medium response for the guided wave or surface wave mode of the wave-propagating structure.
4. The antenna of claim 1, wherein the plurality of adjustable individual electromagnetic responses is a plurality of magnetic dipole radiation fields.
5. The antenna of claim 1, wherein the operating frequency is a microwave frequency.
6. The antenna of claim 5, wherein the microwave frequency is a Ka band frequency.
7. The antenna of claim 5, wherein the microwave frequency is a Ku band frequency.
8. The antenna of claim 5, wherein the microwave frequency is a Q band frequency.

9. The system of claim 1, wherein the inter-element spacing is less than one-fourth of the free space wavelength.
10. The system of claim 1, wherein the inter-element spacing is less than one-fifth of the free space wavelength.
11. The antenna of claim 1, wherein the wave-propagating structure includes one or more conducting surfaces and the plurality of scattering elements corresponds to a plurality of apertures within the one or more conducting surfaces.
12. The antenna of claim 11, wherein the wave-propagating structure is a substantially two-dimensional wave-propagating structure.
13. The antenna of claim 12, wherein the substantially two-dimensional wave-propagating structure is a parallel plate waveguide, and the one or more conducting surfaces are an upper conductor of the parallel plate waveguide.
14. The antenna of claim 11, wherein the wave-propagating structure includes one or more substantially one-dimensional wave-propagating structures.
15. The antenna of claim 14, wherein the one or more substantially one-dimensional wave-propagating structures are a plurality of substantially one-dimensional wave-propagating structures composing a substantially two-dimensional antenna area.
16. The antenna of claim 14, wherein the one or more substantially one-dimensional wave-propagating structures include one or more microstrips.
17. The antenna of claim 16, wherein the one or more conducting surfaces are one or more respective upper conductors of the one or more microstrips.
18. The antenna of claim 16, wherein the one or more conducting surfaces are one or more conducting strips positioned parallel to one or more upper conductors of the one or more microstrips.

19. The antenna of claim 14, wherein the one or more substantially one-dimensional wave-propagating structures include one or more coplanar waveguides.
20. The antenna of claim 19, wherein the one or more conducting surfaces are positioned above the one or more coplanar waveguides.
21. The antenna of claim 14, wherein the one or more substantially one-dimensional wave-propagating structures include one or more closed waveguides.
22. The antenna of claim 21, wherein the one or more closed waveguides include one or more rectangular waveguides.
23. The antenna of claim 22, wherein the one or more rectangular waveguides includes one or more double-ridged rectangular waveguides.
24. The antenna of claim 21, wherein the one or more conducting surfaces are one or more respective upper surfaces of the one or more closed waveguides.
25. The antenna of claim 21, wherein the one or more conducting surfaces are positioned above one or more respective upper surfaces of the one or more closed waveguides, and the one or more respective upper surfaces include a plurality of irises adjacent to the plurality of apertures within the one or more conducting surfaces
26. The antenna of claim 11, wherein the plurality of apertures defines a respective plurality of conducting islands that are electrically disconnected from the one or more conducting surfaces, and the antenna further comprises:  
a plurality of bias voltage lines configured to provide respective bias voltages  
between the one or more conducting surfaces and the respective plurality  
of conducting islands; and  
an electrically adjustable material disposed at least partially within respective  
vicinities of the plurality of apertures.
27. The antenna of claim 26, wherein the electrically adjustable material is a liquid crystal material.



28. The antenna of claim 27, wherein the liquid crystal material is a nematic liquid crystal.
29. The antenna of claim 27, wherein the liquid crystal material is a dual-frequency liquid crystal.
30. The antenna of claim 27, wherein the liquid crystal material is a polymer network liquid crystal.
31. The antenna of claim 27, wherein the liquid crystal material is a polymer dispersed liquid crystal.
32. The antenna of claim 11, wherein the plurality of apertures defines a respective plurality of conducting islands that are electrically disconnected from the one or more conducting surfaces, the plurality of apertures are arranged in rows and columns, and the antenna further comprises:
  - a plurality of biasing circuits configured to provide respective bias voltages between the one or more conducting surfaces and the respective plurality of conducting islands;
  - a set of row control lines each addressing a row of the plurality of biasing circuits;
  - a set of column control lines each addressing a column of the plurality of biasing circuits; and
  - an electrically adjustable material disposed at least partially within respective vicinities of the plurality of apertures.
33. The antenna of claim 32, wherein the plurality of biasing circuits are arranged in rows and columns respectively adjacent to the plurality of apertures.
34. The antenna of claim 11, wherein the plurality of apertures defines a plurality of complementary metamaterial elements having a plurality of magnetic dipole responses to a magnetic field of the guided wave or surface wave.
35. The antenna of claim 34, wherein the plurality of complementary metamaterial elements is a plurality of complementary electric LC metamaterial elements.

36. The antenna of claim 34, wherein the plurality of magnetic dipole responses is a plurality of in-plane magnetic dipole responses oriented parallel to the one or more conducting surfaces.
37. The antenna of claim 36, wherein the plurality of in-plane magnetic dipole responses includes a first plurality of in-plane magnetic dipole responses oriented in a first direction parallel to the one or more conducting surfaces and a second plurality of in-plane magnetic dipole responses oriented in a second direction perpendicular to the first direction and parallel to the one or more conducting surfaces
38. A method, comprising:  
propagating a first guided wave or surface wave to deliver a first plurality of relative phases to a respective plurality of locations;  
coupling to the first guided wave or surface wave at a first set of locations selected from the respective plurality of locations to produce a first plurality of electromagnetic oscillations at the first set of locations, the first plurality of electromagnetic oscillations producing a first radiation field;  
propagating a second guided wave or surface wave to deliver a second plurality of relative phases to the respective plurality of locations, where the second plurality of relative phases is substantially equal to the first plurality of relative phases; and  
coupling to the second guided wave or surface wave at a second set of locations selected from the respective plurality of locations to produce a second plurality of electromagnetic oscillations at the second set of locations, the second plurality of electromagnetic oscillations producing a second radiation field different from the first radiation field.
39. The method of claim 38, wherein:  
the first guided wave or surface wave and the first radiation field define a first interference pattern, and the first set of locations selected from the

respective plurality of locations corresponds to a set of locations within constructive interference regions of the first interference pattern; and the second guided wave or surface wave and the second radiation field define a second interference pattern different from the first interference pattern, and the second set of locations selected from the respective plurality of locations corresponds to a set of locations within constructive interference regions of the second interference pattern.

40. A method, comprising:  
receiving a first free-space wave at a plurality of locations;  
coupling to the first free-space wave at a first set of locations selected from the plurality of locations to produce a first plurality of electromagnetic oscillations at the first set of locations, the first plurality of electromagnetic oscillations producing a first guided wave or surface wave having a first plurality of relative phases at the plurality of locations;  
receiving a second free-space wave different from the first free-space wave at the plurality of locations;  
coupling to the second free-space wave at a second set of locations selected from the plurality of locations to produce a second plurality of electromagnetic oscillations at the second set of locations, the second plurality of electromagnetic oscillations producing a second guided wave or surface wave having a second plurality of relative phases at the plurality of locations, where the second plurality of relative phases is substantially equal to the first plurality of relative phases.
41. The method of claim 40, wherein:  
the first guided wave or surface wave and the first free-space wave define a first interference pattern, and the first set of locations selected from the respective plurality of locations corresponds to a set of locations within constructive interference regions of the first interference pattern; and  
the second guided wave or surface wave and the second free-space wave define a second interference pattern different from the first interference pattern,

and the second set of locations selected from the respective plurality of locations corresponds to a set of locations within constructive interference regions of the second interference pattern.

42. A method, comprising:  
selecting a first antenna radiation pattern; and  
for a surface scattering antenna that is adjustable responsive to one or more control inputs, determining first values of the one or more control inputs corresponding to the first selected antenna radiation pattern.
43. The method of claim 42, wherein the surface scattering antenna has a plurality of scattering elements with respective adjustable physical parameters that are functions of the one or more control inputs.
44. The method of claim 43, wherein the determining of the first values of the one or more control inputs includes:  
determining respective first values of the respective adjustable physical parameters to provide the first selected antenna radiation pattern; and  
determining the first values of the one or more control inputs corresponding to the determined respective first values of the respective adjustable physical parameters.
45. The method of claim 43, wherein the respective adjustable physical parameters are respective adjustable resonance frequencies of the plurality of scattering elements.
46. The method of claim 43, wherein the one or more control inputs include a plurality of respective bias voltages for the plurality of scattering elements.
47. The method of claim 43, wherein the plurality of scattering elements are addressable by row and column, and the one or more control inputs includes a set of row inputs and a set of column inputs.

48. The method of claim 43, wherein the plurality of scattering elements are fed by a set of feed lines having adjustable gains, and the one or more control inputs include the adjustable gains.
49. The method of claim 43, further comprising:  
providing the first values of the one or more control inputs for the surface scattering antenna.
50. The method of claim 42, wherein the selecting of the first antenna radiation pattern includes a selecting of an antenna beam direction.
51. The method of claim 50, wherein the antenna beam direction corresponds to a direction of a telecommunications satellite.
52. The method of claim 50, wherein the antenna beam direction corresponds to a direction of a telecommunications base station.
53. The method of claim 50, wherein the antenna beam direction corresponds to a direction of a telecommunications mobile platform.
54. The method of claim 42, wherein the selecting of the first antenna radiation pattern includes a selecting of one or more null directions
55. The method of claim 42, wherein the selecting of the first antenna radiation pattern includes a selecting of an antenna beam width.
56. The method of claim 42, wherein the selecting of the first antenna radiation pattern includes a selecting of an arrangement of multiple beams.
57. The method of claim 42, wherein the selecting of the first antenna radiation pattern includes a selecting of an overall phase.
58. The method of claim 42, wherein the selecting of the first antenna radiation pattern includes a selecting of a polarization state.

59. The method of claim 58, wherein the selected polarization state is a circular polarization state.
60. The method of claim 58, wherein the selected polarization state is a linear polarization state.
61. The method of claim 42, further comprising:  
selecting a second antenna radiation pattern different from the first antenna radiation pattern; and  
determining second values of the one or more control inputs corresponding to the second selected antenna radiation pattern.
62. The method of claim 61, further comprising:  
providing the second values of the one or more control inputs for the surface scattering antenna.
63. The method of claim 61, wherein the selecting of the first antenna radiation pattern includes a selecting of a first antenna beam direction, and the selecting of the second antenna radiation pattern includes a selecting of a second antenna beam direction different from the first antenna beam direction.
64. The method of claim 63, wherein the first selected antenna radiation pattern provides a first polarization state corresponding to the first antenna beam direction, the second selected antenna radiation pattern provides a second polarization state corresponding to the second antenna beam direction, and the first polarization state is substantially equal to the second polarization state.
65. The method of claim 64, wherein the first and second polarization states are circular polarization states.
66. The method of claim 64, wherein the first and second polarization states are linear polarization states.
67. The method of claim 63, wherein the first and second antenna beam directions correspond to directions of first and second telecommunications satellites.

68. The method of claim 63, wherein the first and second antenna beam directions correspond to directions of first and second objects selected from a plurality of objects including telecommunications satellites, telecommunications base stations, or telecommunications mobile platforms.
69. A method, comprising:  
identifying a first target for a first surface scattering antenna, the first surface scattering antenna having a first adjustable radiation pattern responsive to one or more first control inputs; and  
repeatedly adjusting the one or more first control inputs to provide a substantially continuous variation of the first adjustable radiation pattern responsive to a first relative motion between the first target and the first surface scattering antenna.
70. The method of claim 69, wherein the first relative motion is a translation of the first target.
71. The method of claim 69, wherein the first relative motion is a translation or rotation of the first surface scattering antenna.
72. The method of claim 69, wherein the first relative motion is a combination of a translation of the first target and a translation or rotation of the first surface antenna.
73. The method of claim 69, wherein the substantially continuous variation of the first adjustable radiation pattern is selected to keep the first target substantially within a primary beam of the first adjustable radiation pattern.
74. The method of claim 69, wherein the substantially continuous variation of the first adjustable radiation pattern is selected to keep the first target substantially at a null of the first adjustable radiation pattern.

75. The method of claim 69, wherein the substantially continuous variation of the first adjustable radiation pattern is selected to provide a substantially constant polarization state at a location of the first target.
76. The method of claim 75, wherein the substantially constant polarization state is a circular polarization state.
77. The method of claim 75, wherein the substantially constant polarization state is a linear polarization state.
78. The method of claim 69, wherein the first target is a telecommunications satellite.
79. The method of claim 69, wherein the first target is a telecommunications base station.
80. The method of claim 69, wherein the first target is a telecommunications mobile platform.
81. The method of claim 69, further comprising:
  - identifying a second target for a second surface scattering antenna, the second surface scattering antenna having a second adjustable radiation pattern responsive to one or more second control inputs; and
  - repeatedly adjusting the one or more second control inputs to provide a substantially continuous variation of the second adjustable radiation pattern responsive to a relative motion between the second target and the second surface scattering antenna.
82. The method of claim 81, wherein the first and second targets are members of a constellation of telecommunications satellites.
83. The method of claim 81, wherein the first relative motion is a translation of the first target, and the second relative motion is a translation of the second target.
84. The method of claim 81, wherein:



- the first relative motion is a combination of a translation of the first target and a translation or rotation of the first surface antenna;
- the second relative motion is a combination of a translation of the second target and a translation or rotation of the second surface antenna; and
- the translation or rotation of the first surface antenna is equal to the translation or rotation of the second surface antenna.
85. The method of claim 81, wherein the substantially continuous variation of the first adjustable radiation pattern is selected to keep the first target substantially within a primary beam of the first adjustable radiation pattern, and the substantially continuous variation of the second adjustable radiation pattern is selected to keep the second target substantially within a primary beam of the second adjustable radiation pattern.
86. The method of claim 85, further comprising:  
adjusting the one or more first control inputs to place the second target substantially within the primary beam of the first adjustable radiation pattern.
87. The method of claim 86, further comprising:  
identifying a new target for a second surface scattering antenna different from the first and second targets; and  
adjusting the one or more second control inputs to place the new target substantially within the primary beam of the second adjustable radiation pattern.
88. A system, comprising:  
a surface scattering antenna that is adjustable responsive to one or more control inputs;  
antenna control circuitry configured to provide the one or more control inputs;  
and  
communications circuitry coupled to a feed structure of the surface scattering antenna.

89. The system of claim 88, wherein the surface scattering antenna has a plurality of scattering elements with respective adjustable physical parameters that are functions of the one or more control inputs.
90. The system of claim 89, wherein the one or more control inputs include a plurality of respective bias voltages for the plurality of scattering elements.
91. The system of claim 89, wherein the plurality of scattering elements are addressable by row and column, and the one or more control inputs includes a set of row inputs and a set of column inputs.
92. The system of claim 89, wherein the feed structure includes a plurality of feeds having a respective plurality of amplifiers, and the one or more control inputs include adjustable gains of the respective plurality of amplifiers.
93. The system of claim 88, wherein the antenna control circuitry includes:  
a storage medium that includes a lookup table mapping a set of antenna radiation pattern parameters to a corresponding set of values for the one or more control inputs.
94. The system of claim 93, wherein the set of antenna radiation pattern parameters includes a set of antenna beam directions.
95. The system of claim 93, wherein the set of antenna radiation pattern parameters includes a set of antenna null directions.
96. The system of claim 93, wherein the set of antenna radiation pattern parameters includes a set of antenna beam widths.
97. The system of claim 93, wherein the set of antenna radiation pattern parameters includes a set of polarization states.
98. The system of claim 88, wherein the antenna control circuitry includes:

processor circuitry configured to calculate a set of values for the one or more control inputs corresponding to a desired antenna radiation pattern parameter.

99. The system of claim 98, wherein the processor circuitry is configured to calculate the set of values for the for the one or more control inputs by computing a holographic pattern corresponding to the desired antenna radiation pattern parameter.
100. The system of claim 88, further comprising:  
a sensor unit configured to detect an environmental condition of the surface scattering antenna.
101. The system of claim 100, wherein the sensor unit includes one or more sensors selected from GPS sensors, thermometers, gyroscopes, accelerometers, and strain gauges.
102. The system of claim 100, wherein the environmental condition includes a position, an orientation, a temperature, or a mechanical deformation of the surface scattering antenna.
103. The system of claim 100, wherein the sensor unit is configured to provide environmental condition data to the antenna control circuitry, and the antenna control circuitry includes:  
circuitry configured to adjust the one or more control inputs to compensate for changes in the environmental condition of the surface scattering antenna.

1/16  
FIG. 1

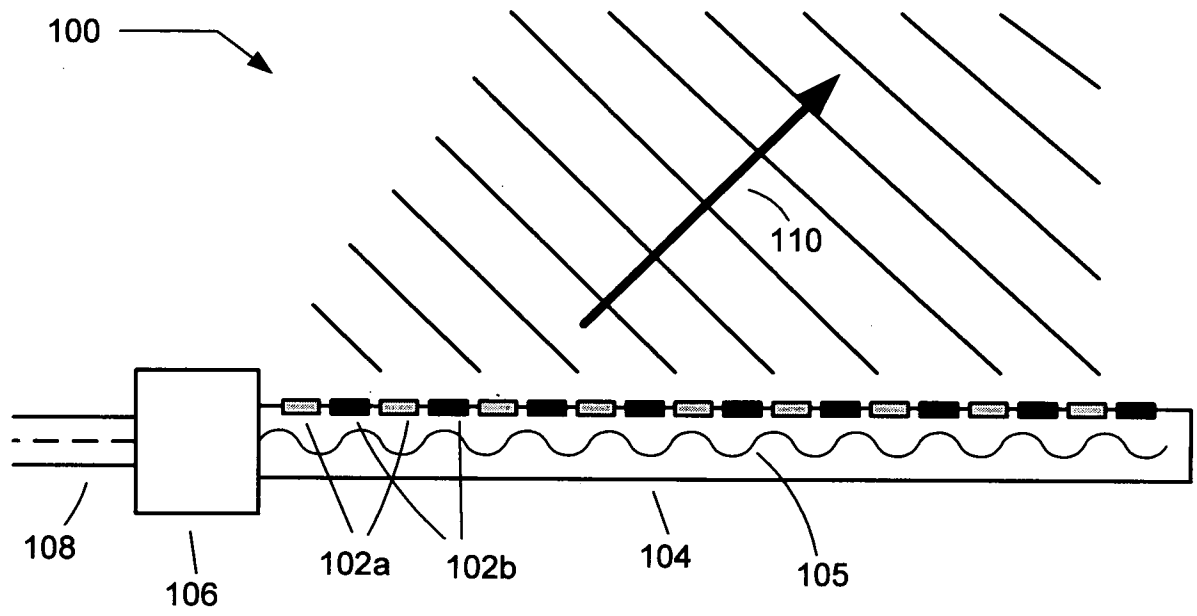

2/16  
FIG. 2A

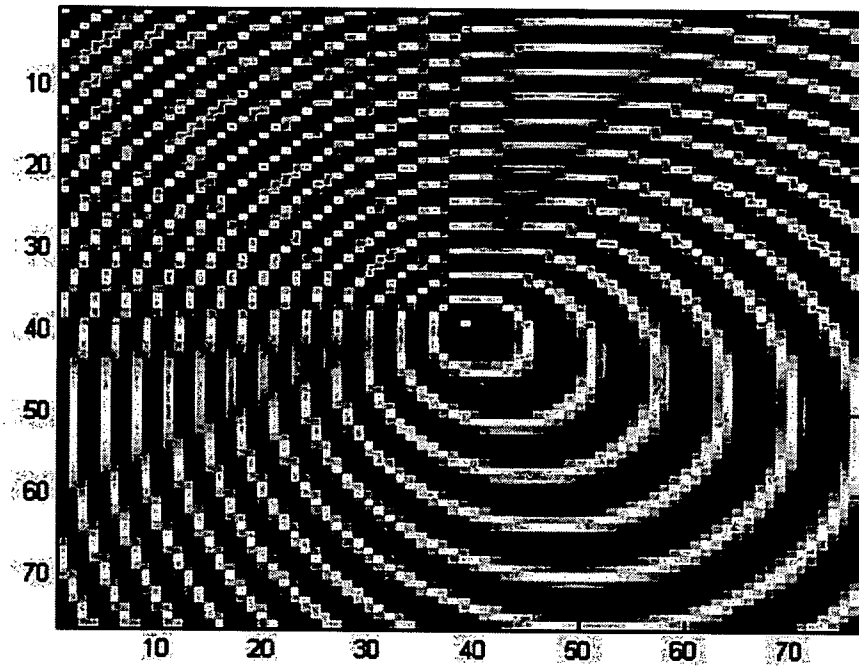
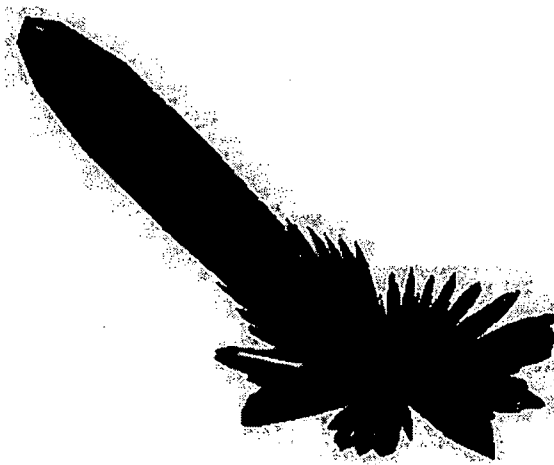

FIG. 2B



3/16  
FIG. 3A

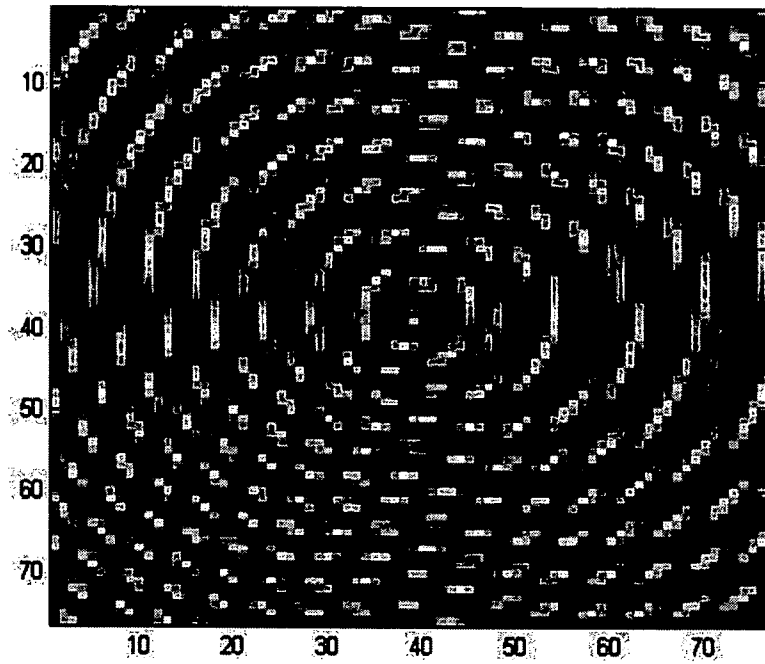
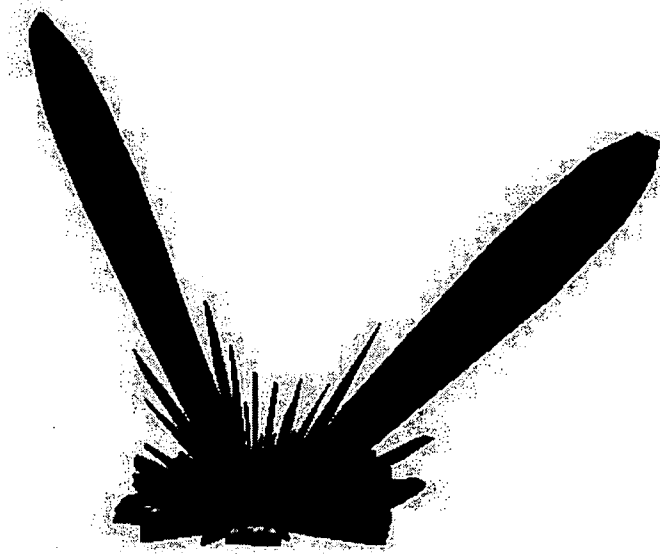

FIG. 3B



4/16  
FIG. 4A

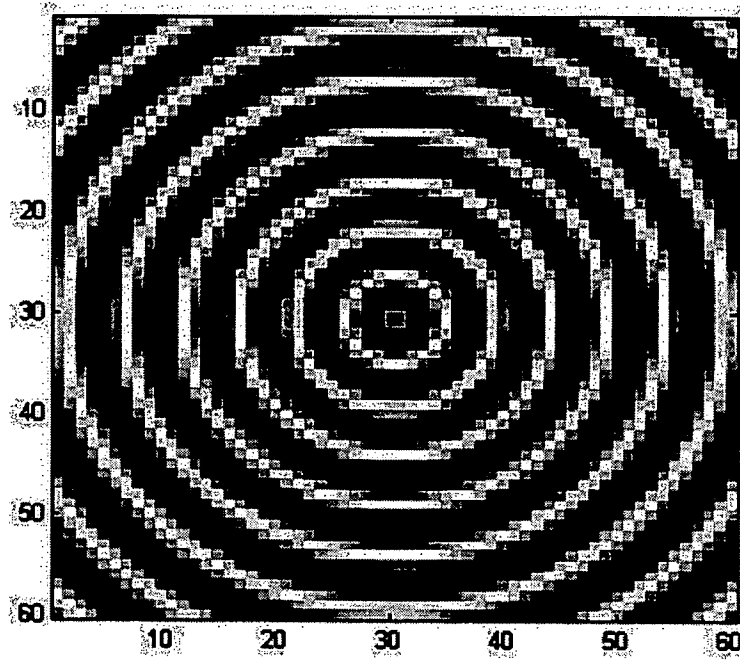
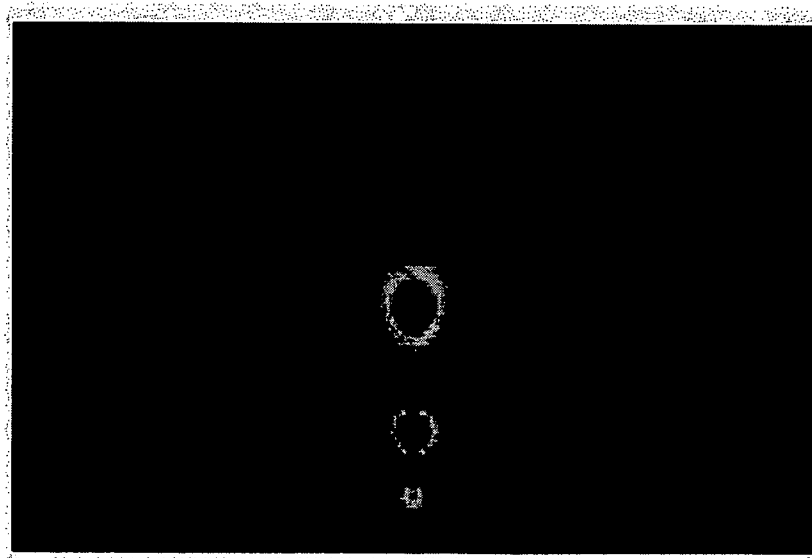
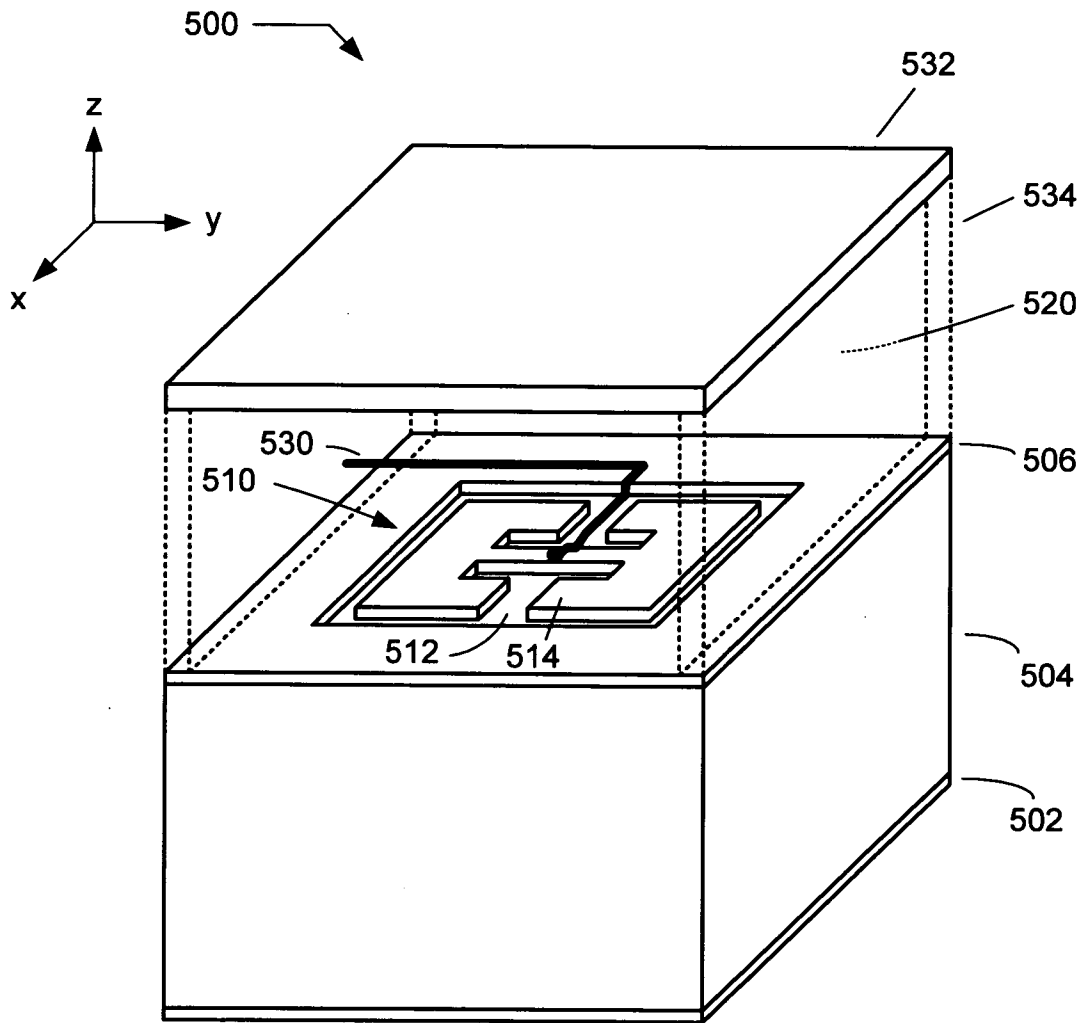

FIG. 4B



5/16  
FIG. 5





6/16  
FIG. 6

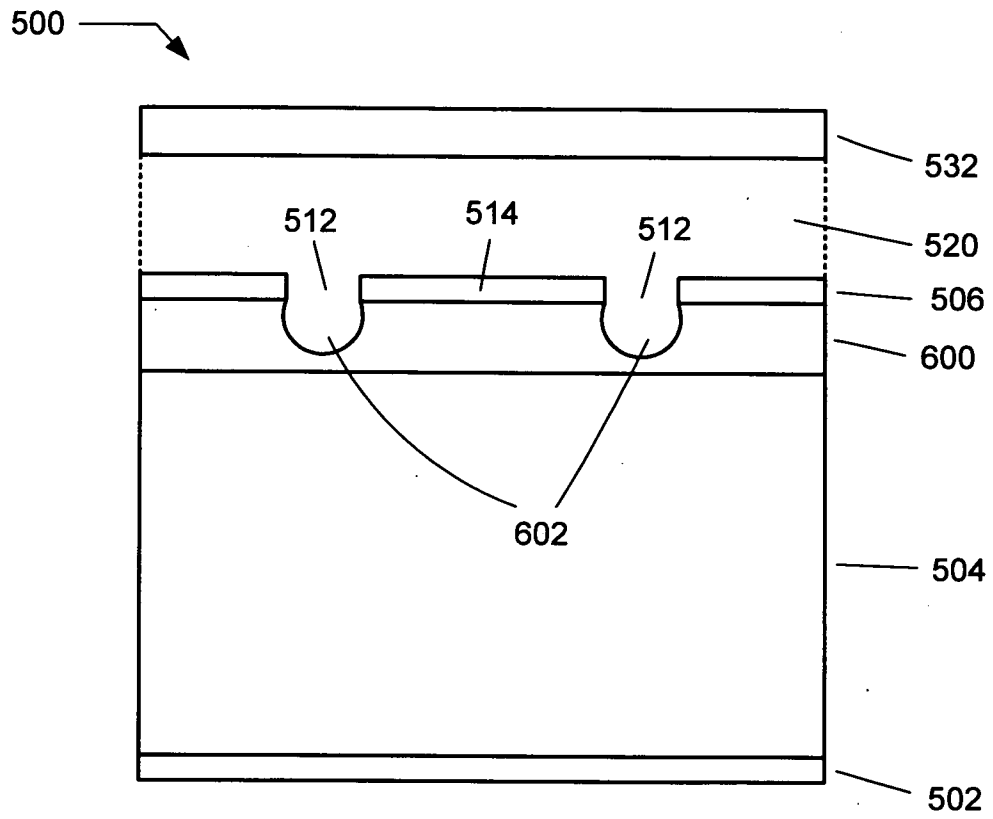

7/16

FIG. 7A

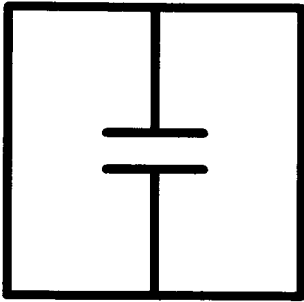

FIG. 7B

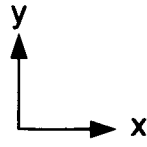
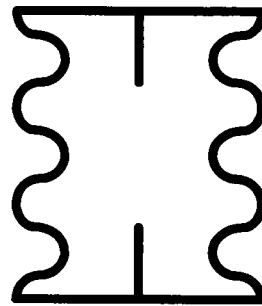

FIG. 7C

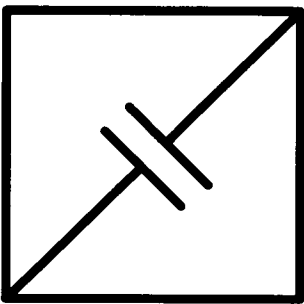

FIG. 7D

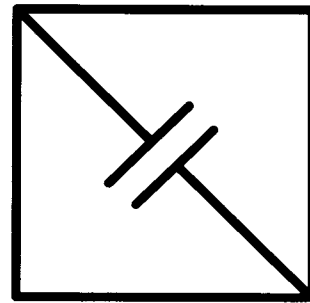

FIG. 7E

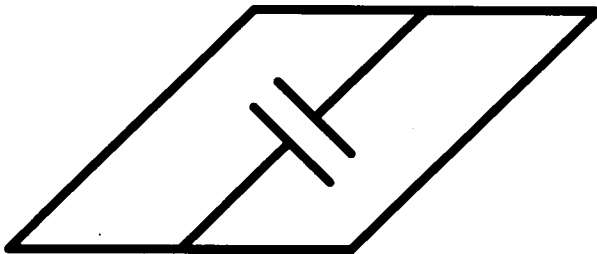

FIG. 7F

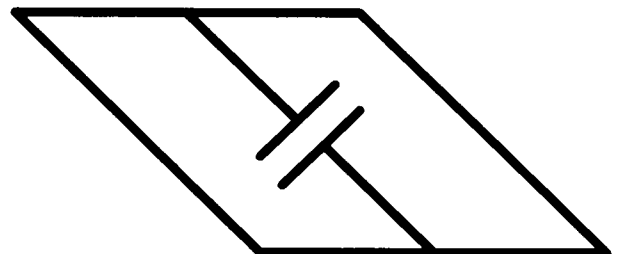

FIG. 7G

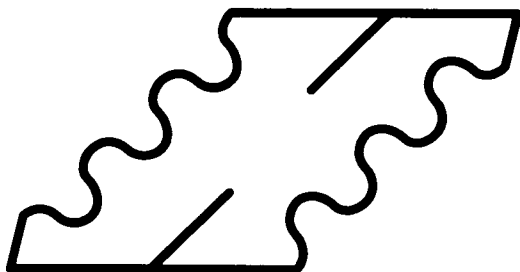
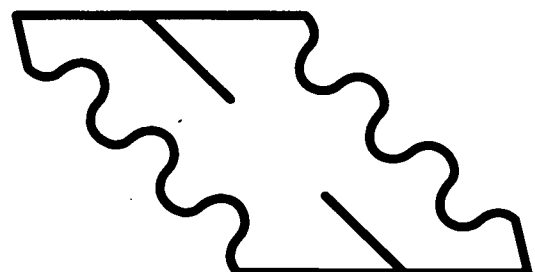
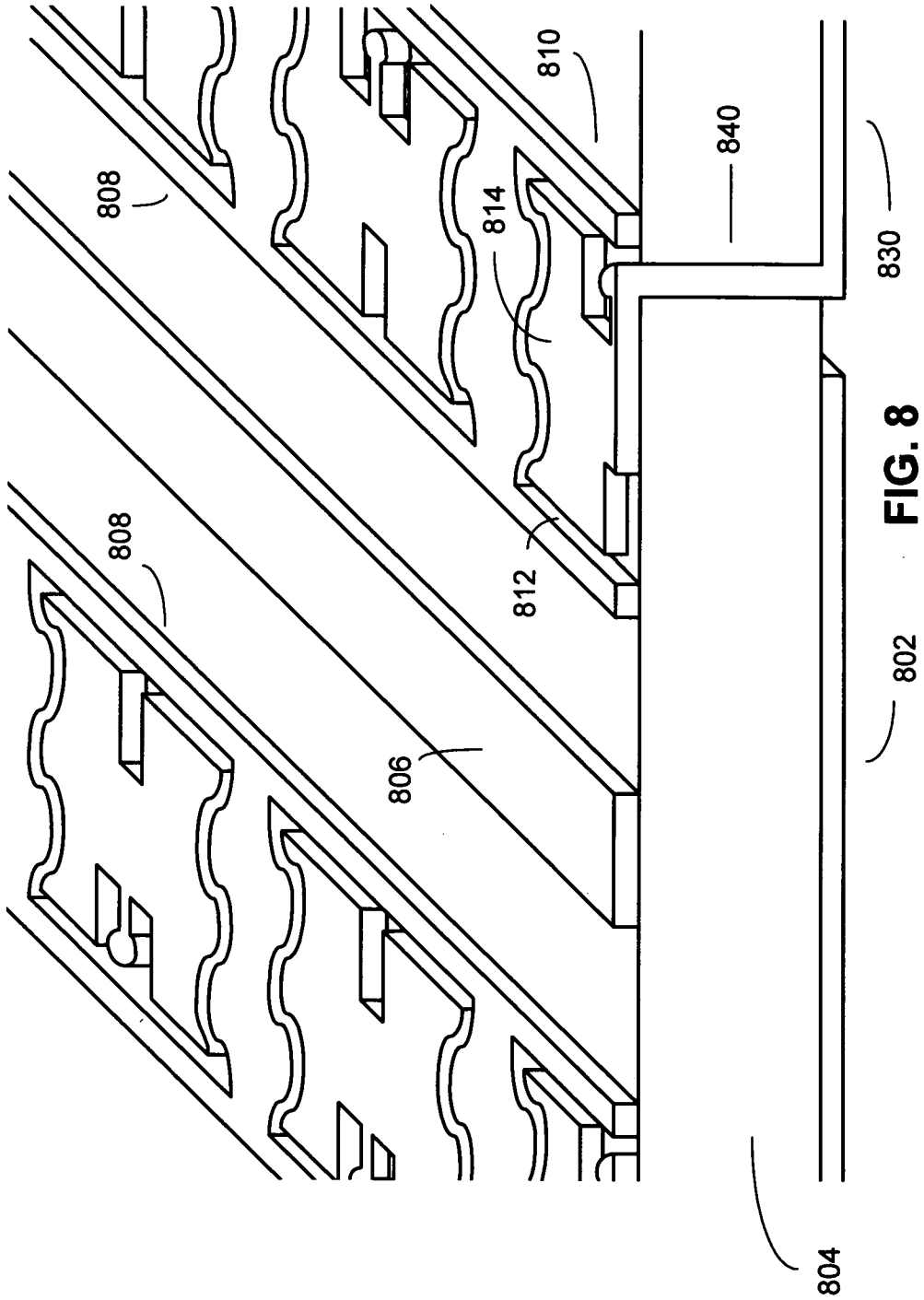

FIG. 7H



8/16



9/16  
FIG. 9A

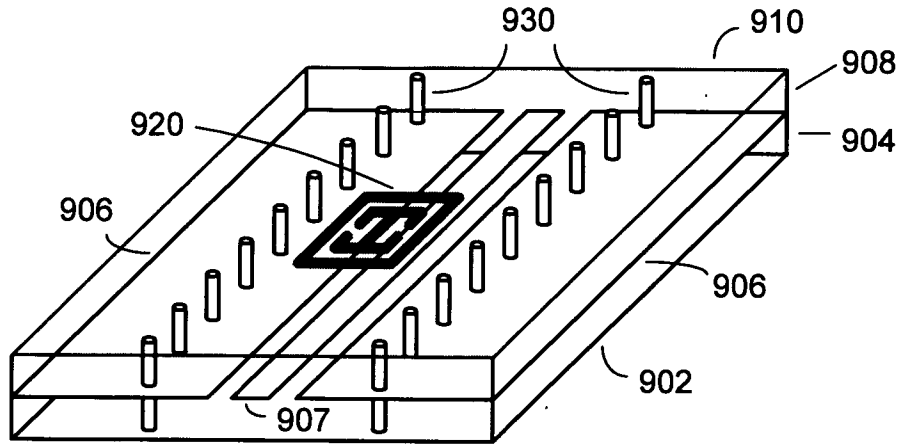
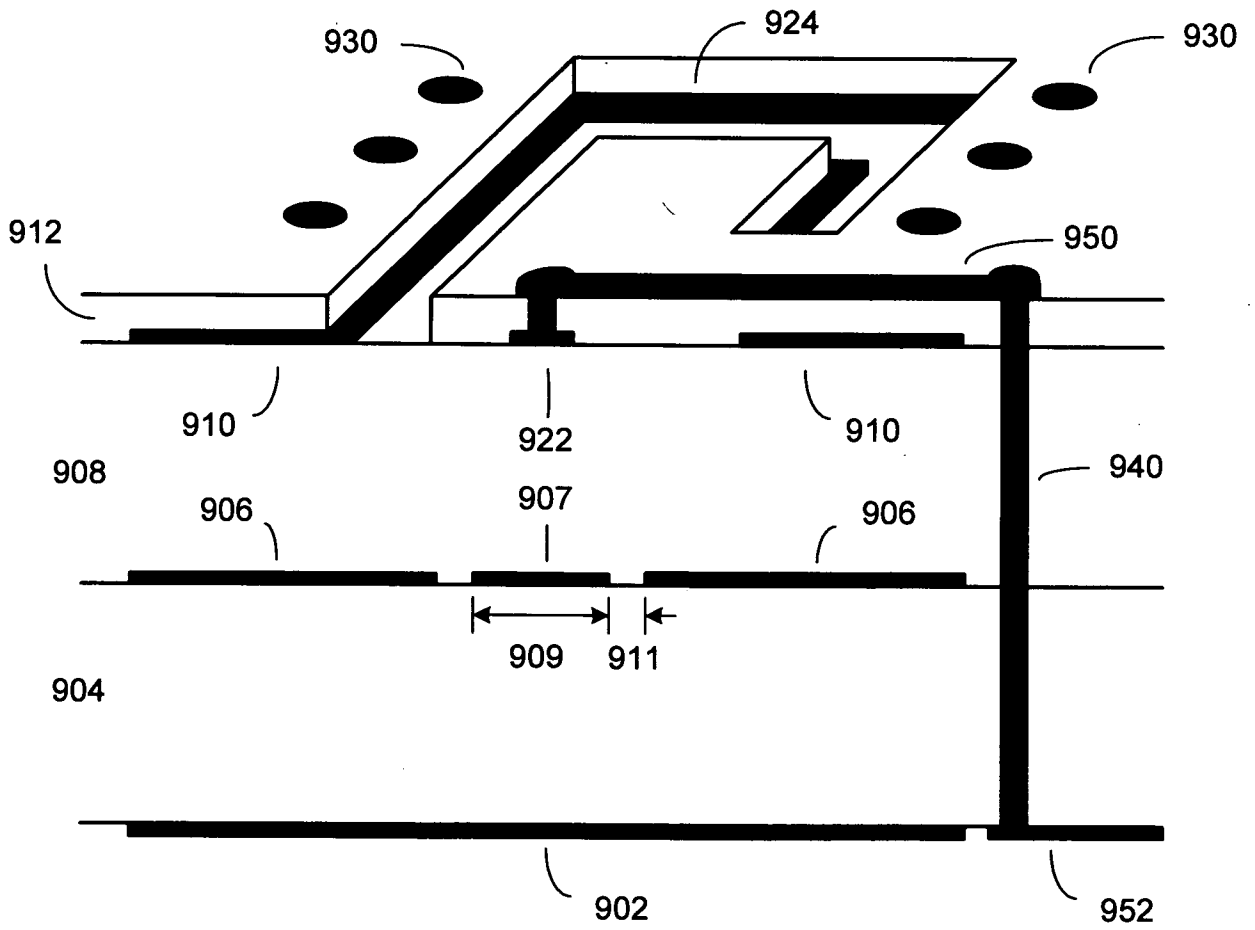
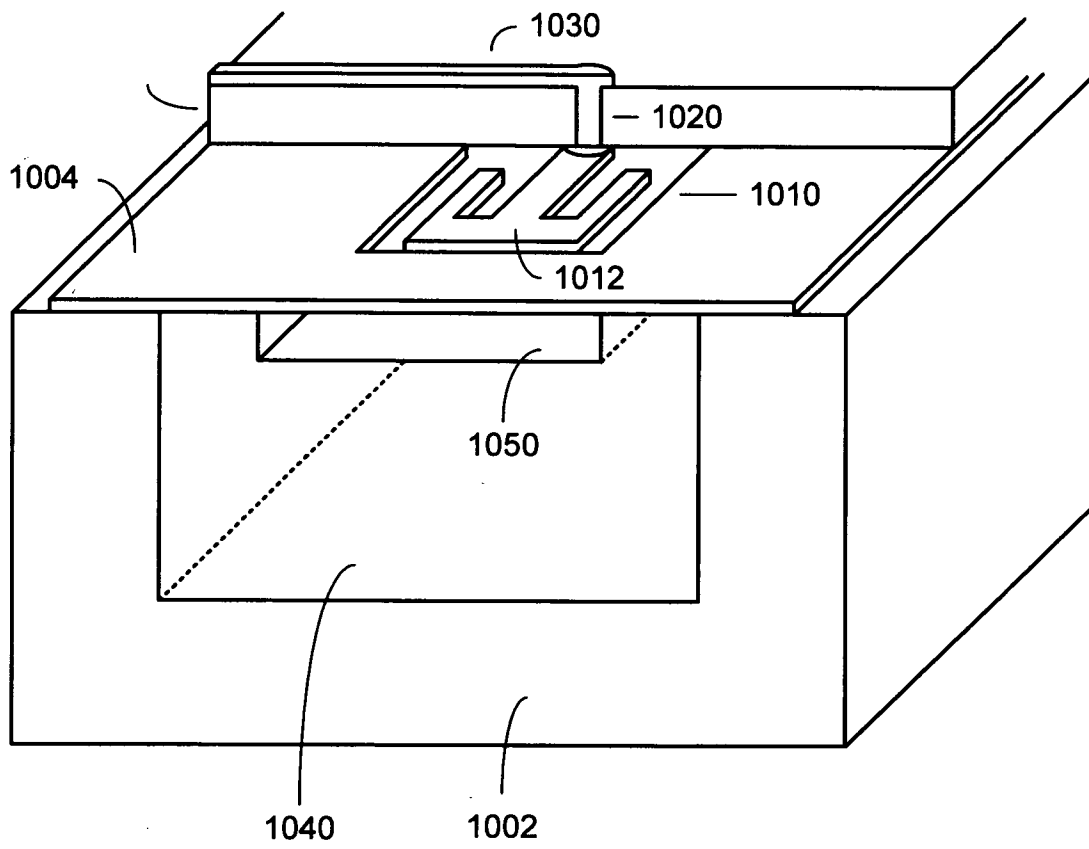

FIG. 9B



10/16  
FIG. 10



11/16  
FIG. 11

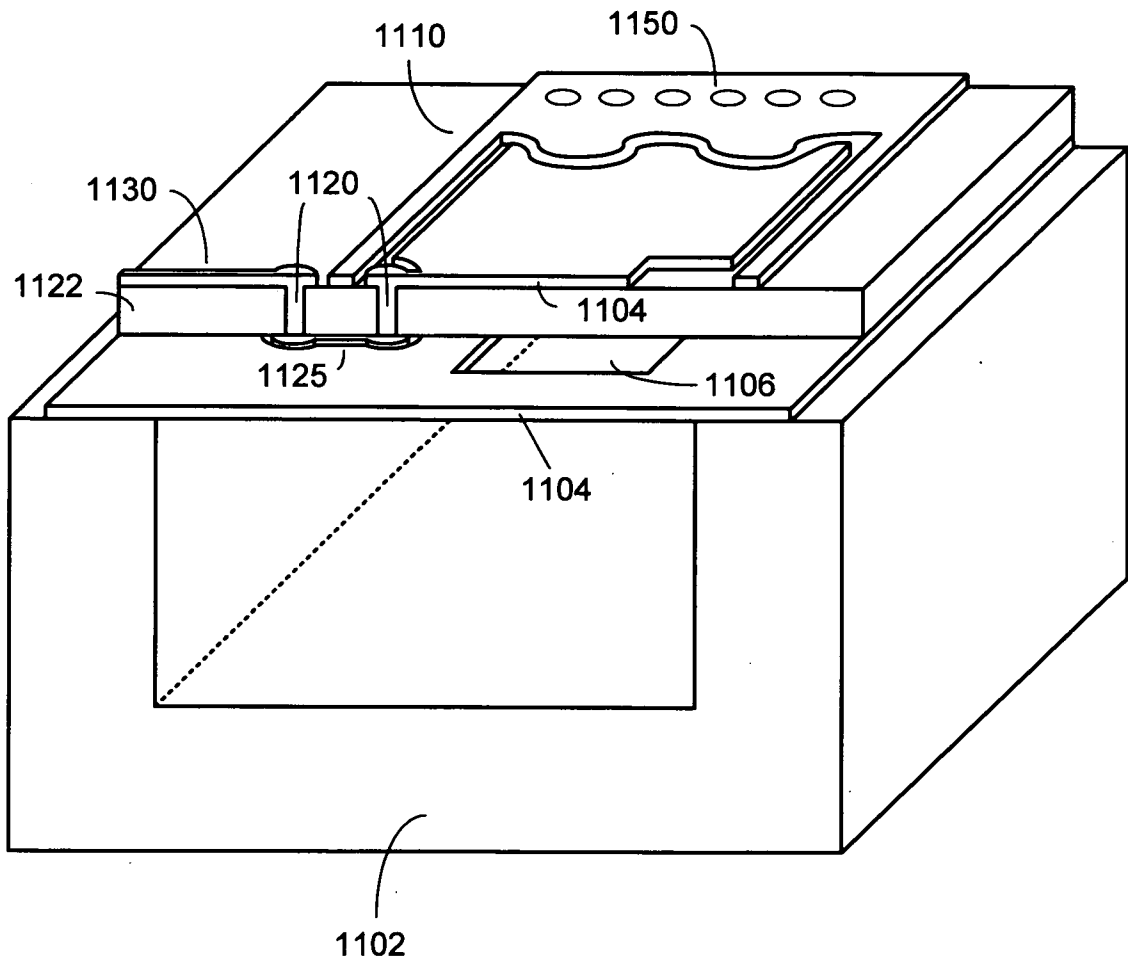

12/16  
FIG. 12

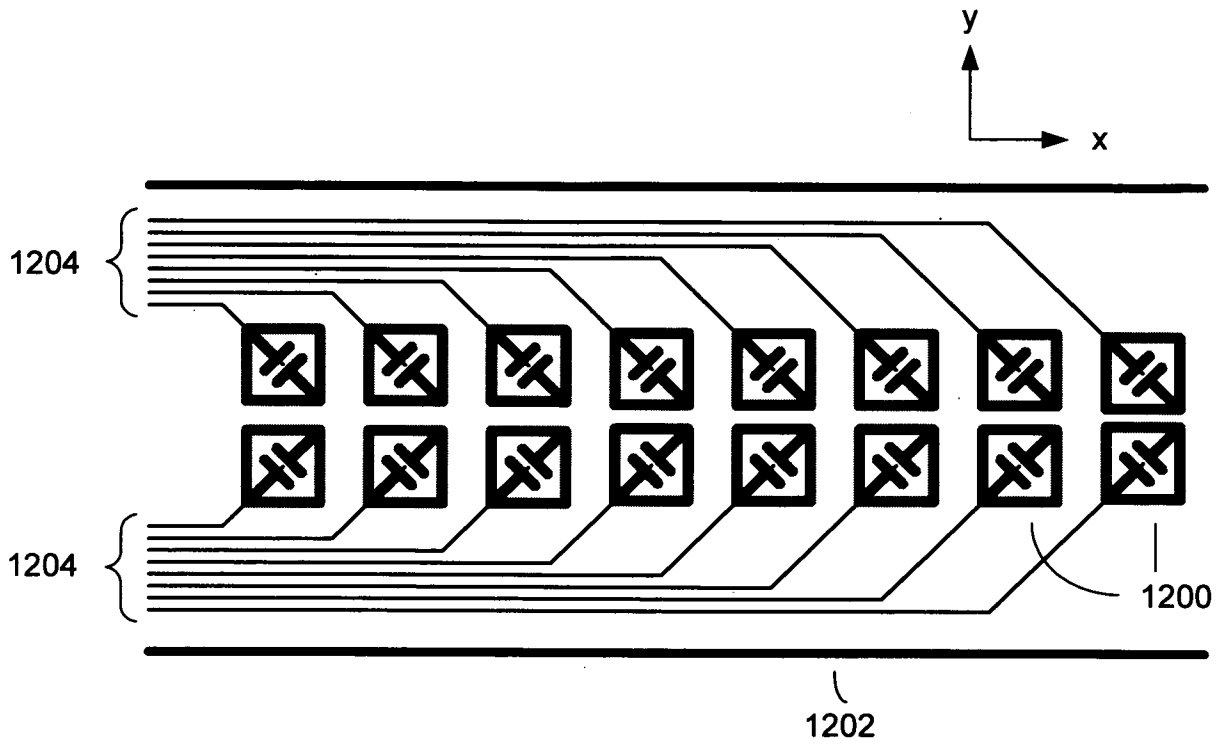

13/16  
FIG. 13

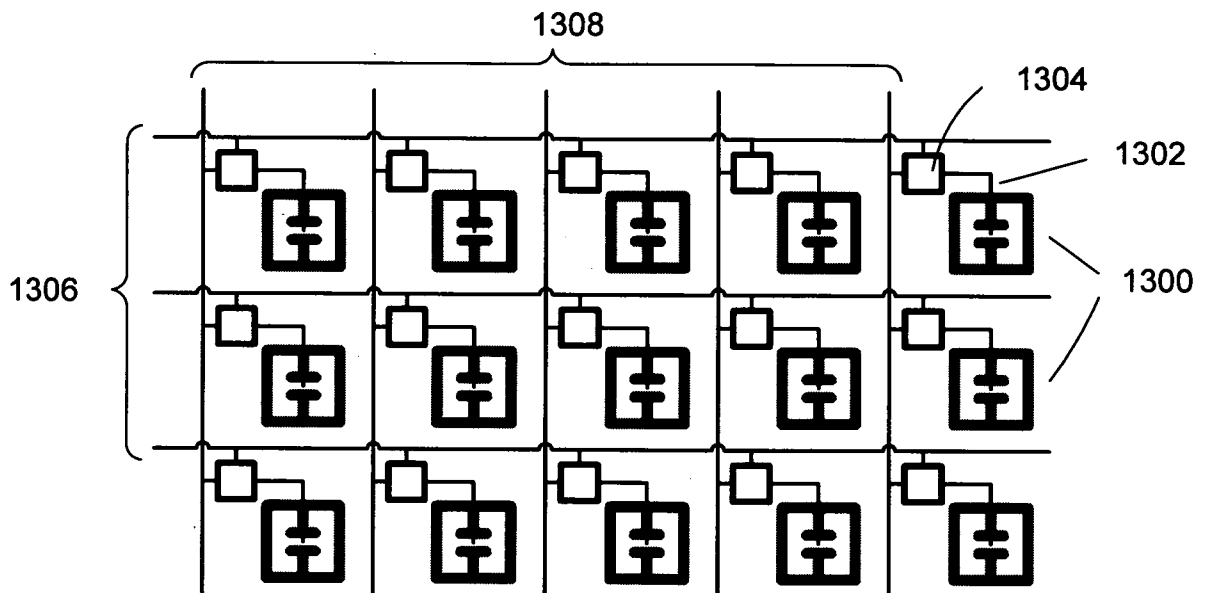



14/16  
FIG. 14

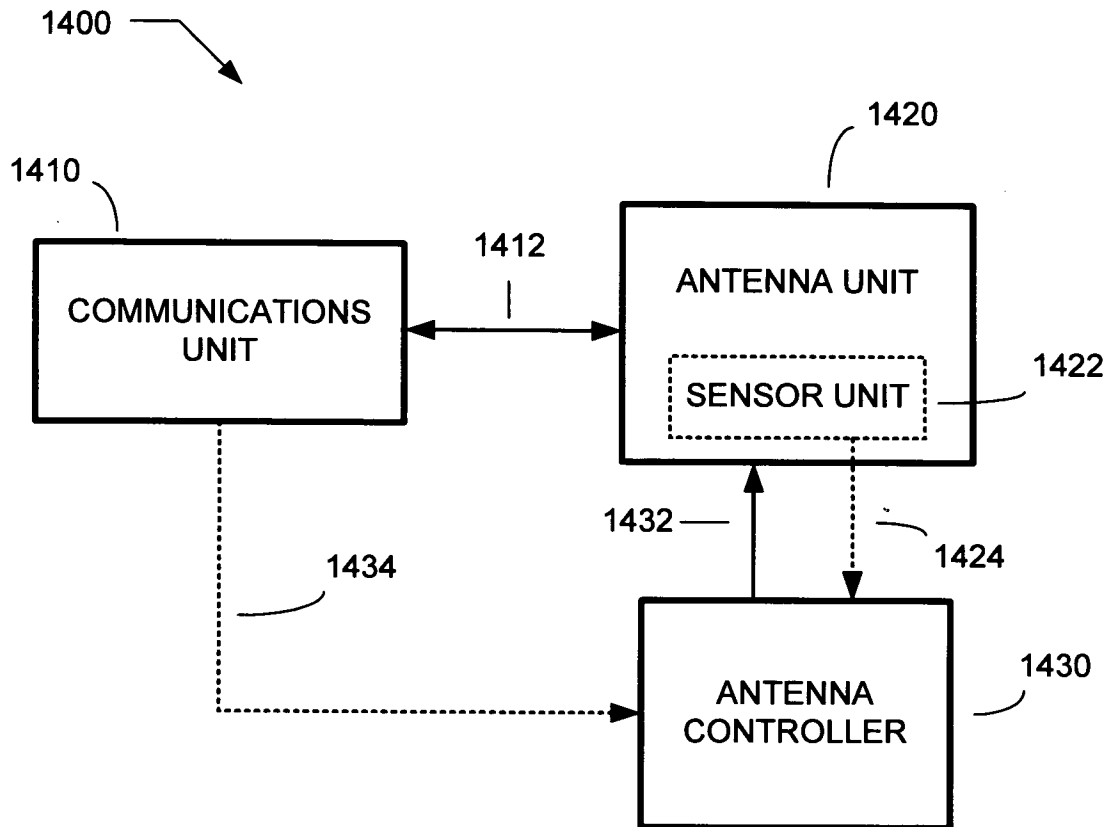

15/16  
**FIG. 15**

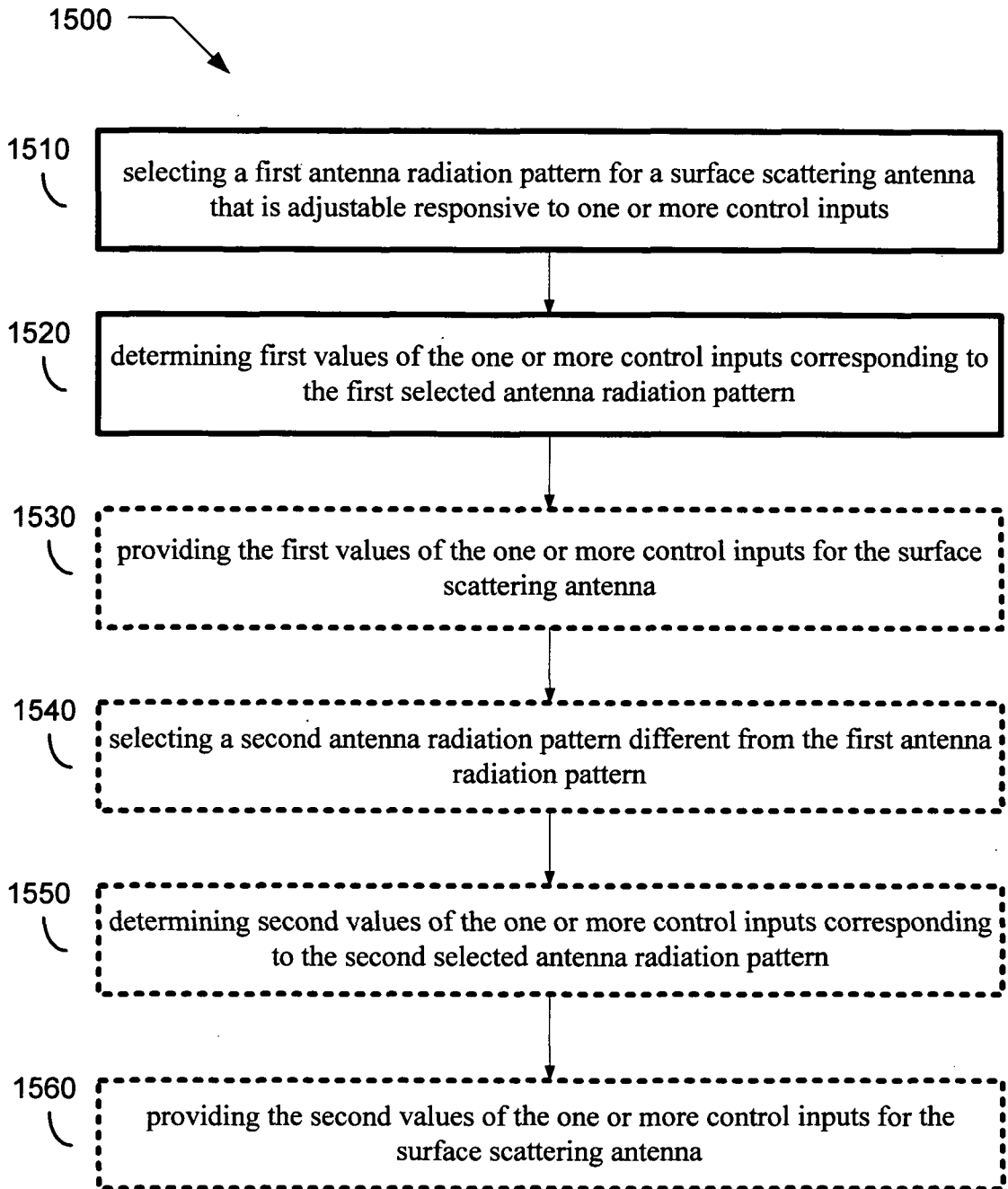

16/16  
FIG. 16

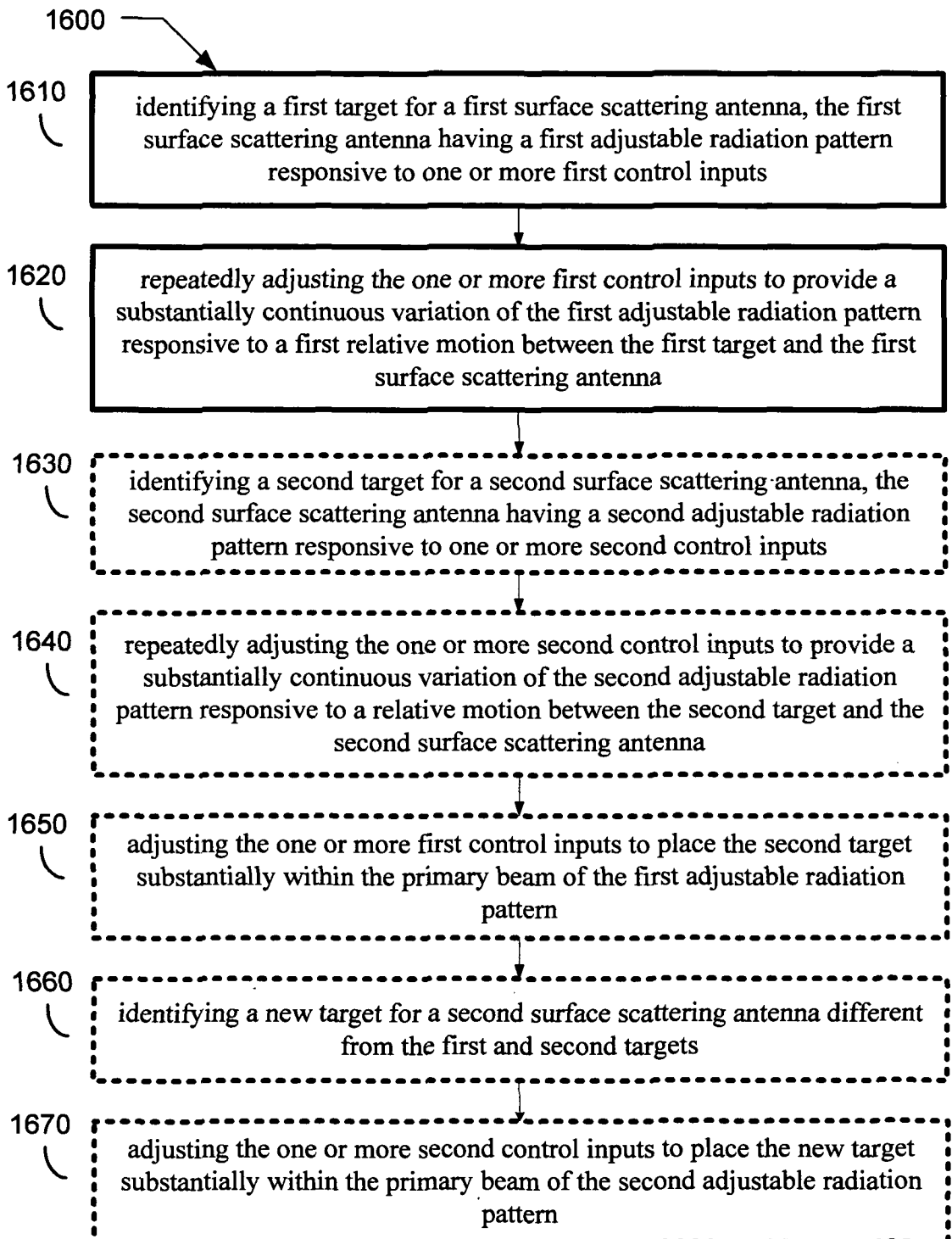

**INTERNATIONAL SEARCH REPORT**

International application No.  
PCT/US2011/001755

**A. CLASSIFICATION OF SUBJECT MATTER**  
IPC(8) - H01Q 1/00 (2012.01)  
USPC - 343/700R  
According to International Patent Classification (IPC) or to both national classification and IPC

**B. FIELDS SEARCHED**  
Minimum documentation searched (classification system followed by classification symbols)  
IPC(8) - H01Q 1/36, 38, 3/00, 26, 44, 46, 9/00, 04, 13/20, 15/00, 21/06, 23/00, 25/00 (2012.01)  
USPC - 343/700R, 700MS, 705, 709, 745, 750-751, 754, 756-757

Documentation searched other than minimum documentation to the extent that such documents are included in the fields searched

Electronic data base consulted during the international search (name of data base and, where practicable, search terms used)  
PatBase, Google Patent, Google Scholar

**C. DOCUMENTS CONSIDERED TO BE RELEVANT**

Category*	Citation of document, with indication, where appropriate, of the relevant passages	Relevant to claim No.
X	US 2004/0227668 A1 (SIEVENPIPER) 18 November 2004 (18.11.2004) entire document	1-3, 5, 9-13, 42-50, 55-58, 60-64, 66, 88-91
---		
Y		4, 6-8, 14-37, 51-54, 59, 65, 67-87, 92-103
Y	US 2008/0224707 A1 (WISLER et al) 18 September 2008 (18.09.2008) entire document	4, 36-37
Y	US 7,307,596 B1 (WEST) 11 December 2007 (11.12.2007) entire document	6-8, 21-25
Y	US 4,291,312 A (KALO) 22 September 1981 (22.08.1981) entire document	14-25
Y	US 4,978,934 A (SAAD) 18 December 1990 (18.12.1990) entire document	23
Y	US 6,552,696 B1 (SIEVENPIPER et al) 22 April 2003 (22.04.2003) entire document	26-33
Y	US 2010/0156573 A1 (SMITH et al) 24 June 2010 (24.06.2010) entire document	34-37
Y	US 6,061,023 A (DANIEL et al) 09 May 2000 (09.05.2000) entire document	51-54, 67-68, 74, 95
Y	US 2008/0180339 A1 (YAGI) 31 July 2008 (31.07.2008) entire document	59, 65
Y	US 6,075,483 A (GROSS) 13 June 2000 (13.06.2000) entire document	69-87
Y	US 4,920,350 A (MCGUIRE et al) 24 April 1990 (24.04.1990) entire document	71-72, 84

Further documents are listed in the continuation of Box C.

\* Special categories of cited documents:

"A" document defining the general state of the art which is not considered to be of particular relevance	"T" later document published after the international filing date or priority date and not in conflict with the application but cited to understand the principle or theory underlying the invention
"E" earlier application or patent but published on or after the international filing date	"X" document of particular relevance; the claimed invention cannot be considered novel or cannot be considered to involve an inventive step when the document is taken alone
"L" document which may throw doubts on priority claim(s) or which is cited to establish the publication date of another citation or other special reason (as specified)	"Y" document of particular relevance; the claimed invention cannot be considered to involve an inventive step when the document is combined with one or more other such documents, such combination being obvious to a person skilled in the art
"O" document referring to an oral disclosure, use, exhibition or other means	"&" document member of the same patent family
"P" document published prior to the international filing date but later than the priority date claimed	

Date of the actual completion of the international search 15 March 2012	Date of mailing of the international search report <b>22 MAR 2012</b>
--	--

Name and mailing address of the ISA/US Mail Stop PCT, Attn: ISA/US, Commissioner for Patents P.O. Box 1450, Alexandria, Virginia 22313-1450 Facsimile No. 571-273-3201	Authorized officer: Blaine R. Copenheaver PCT Helpdesk: 571-272-4300 PCT OSP: 571-272-7774
---	---

## INTERNATIONAL SEARCH REPORT

International application No.  
PCT/US2011/001755

C (Continuation). DOCUMENTS CONSIDERED TO BE RELEVANT		
Category*	Citation of document, with indication, where appropriate, of the relevant passages	Relevant to claim No.
Y	US 3,001,193 A (MARIE) 19 September 1961 (19.09.1961) entire document	76
Y	US 2006/0116097 A1 (THOMPSON) 01 June 2006 (01.06.2006) entire document	92
Y	US 4,489,325 A (BAUCK et al) 18 December 1984 (18.12.1984) entire document	93-97
Y	US 6,469,672 B1 (MARTI-CANALES et al) 22 October 2002 (22.10.2002) entire document	98-99
Y	WO 2009/103042 A2 (HUANG et al) 20 August 2009 (20.08.2009) entire document	100-103

INTERNATIONAL SEARCH REPORT

International application No.

PCT/US2011/001755

**Box No. II Observations where certain claims were found unsearchable (Continuation of item 2 of first sheet)**

This international search report has not been established in respect of certain claims under Article 17(2)(a) for the following reasons:

- 1.  Claims Nos.:  
because they relate to subject matter not required to be searched by this Authority, namely:
  
- 2.  Claims Nos.:  
because they relate to parts of the international application that do not comply with the prescribed requirements to such an extent that no meaningful international search can be carried out, specifically:
  
- 3.  Claims Nos.:  
because they are dependent claims and are not drafted in accordance with the second and third sentences of Rule 6.4(a).

**Box No. III Observations where unity of invention is lacking (Continuation of item 3 of first sheet)**

This International Searching Authority found multiple inventions in this international application, as follows:

See extra sheet.

- 1.  As all required additional search fees were timely paid by the applicant, this international search report covers all searchable claims.
- 2.  As all searchable claims could be searched without effort justifying additional fees, this Authority did not invite payment of additional fees.
- 3.  As only some of the required additional search fees were timely paid by the applicant, this international search report covers only those claims for which fees were paid, specifically claims Nos.:
  
- 4.  No required additional search fees were timely paid by the applicant. Consequently, this international search report is restricted to the invention first mentioned in the claims; it is covered by claims Nos.:  
1-37, 42-103

**Remark on Protest**

- The additional search fees were accompanied by the applicant's protest and, where applicable, the payment of a protest fee.
- The additional search fees were accompanied by the applicant's protest but the applicable protest fee was not paid within the time limit specified in the invitation.
- No protest accompanied the payment of additional search fees.

Continuation of Box III.

This application contains the following inventions or groups of inventions which are not so linked as to form a single general inventive concept under PCT Rule 13.1. In order for all inventions to be examined, the appropriate additional examination fees must be paid.

Group I, claims 1-37, 42-103, drawn to an antenna having a wave propagating structure; a plurality of scattering elements along the wave propagating structure having inter-element spacings less than a free-space wavelength of the operating frequency of the antenna, the scattering elements have adjustable individual electromagnetic responses to a guided or surface wave mode of the wave propagating structure which provide an adjustable radiation field of the antenna; selecting/identifying a radiation pattern; determining values for control inputs corresponding to the scattering elements which correspond to a selected antenna radiation pattern; adjusting the control inputs to provide a continuous variation of the adjustable radiation pattern responsive to a motion between the target and surface scattering antenna; circuitry to provide the control inputs; and communications circuitry coupled to a feed structure of the surface scattering antenna.

Group II, claims 38-41, drawn to receiving first and second free-space waves at a plurality of locations; coupling the first and second waves to first and second sets of locations selected from the plurality of locations respectively, to produce first and second pluralities of electromagnetic oscillations at the first and second sets of locations respectively, the oscillations producing first and second guided or surface waves having first and second pluralities of relative phases respectively, that are equal to one another.

The inventions listed as Groups I-II do not relate to a single general inventive concept under PCT Rule 13.1 because, under PCT Rule 13.2, they lack the same or corresponding special technical features for the following reasons: the special technical feature of the Group I invention: surface scattering antenna having circuitry to provide control inputs which control the produced radiation pattern of the antenna by adjusting electromagnetic responses of scattering elements; and continuously varying the control inputs to adjust the radiation pattern in response to motion between a target and the surface scattering antenna as claimed therein is not present in the invention of Group II. The special technical feature of the Group II invention: coupling first and second waves to first and second sets of locations selected from the plurality of locations respectively, to produce first and second pluralities of electromagnetic oscillations at the first and second sets of locations respectively, the oscillations producing first and second guided or surface waves having first and second pluralities of relative phases respectively, that are equal to one another as claimed therein is not present in the invention of Groups I.

Groups I and II lack unity of invention because even though the inventions of these groups require the technical feature of a means for receiving a free-space wave at a plurality of locations and oscillations within the device having a plurality of phases, this technical feature is not a special technical feature as it does not make a contribution over the prior art in view of US 2004/0227668 A1 (SIEVENPIPER) 18 November 2004 (18.11.2004) figures 1a-1b, 6, paragraphs 25, 27, 45-47 and 51.

Since none of the special technical features of the Group I or II inventions are found in more than one of the inventions, unity of invention is lacking.