

(19) World Intellectual Property  
Organization  
International Bureau



(43) International Publication Date  
30 June 2005 (30.06.2005)

PCT

(10) International Publication Number  
**WO 2005/059473 A3**

- (51) International Patent Classification<sup>7</sup>: **G01C 15/00**
- (21) International Application Number: PCT/EP2004/014365
- (22) International Filing Date: 16 December 2004 (16.12.2004)
- (25) Filing Language: English
- (26) Publication Language: English
- (30) Priority Data: 103 59 415.9 16 December 2003 (16.12.2003) DE
- (71) Applicant (for all designated States except US): **TRIMBLE JENA GMBH** [DE/DE]; Carl-Zeiss-Promenade 10, 07745 Jena (DE).
- (72) Inventor; and
- (75) Inventor/Applicant (for US only): **VOGEL, Michael** [DE/DE]; Dorfstrasse 29, 07629 Schleifreisen (DE).
- (74) Agents: **FRANK, Dierk** et al.; Geyer, Fehners & Partner, Perhamerstrasse 31, 80687 München (DE).
- (81) Designated States (unless otherwise indicated, for every kind of national protection available): AE, AG, AL, AM, AT, AU, AZ, BA, BB, BG, BR, BW, BY, BZ, CA, CH, CN, CO, CR, CU, CZ, DE, DK, DM, DZ, EC, EE, EG, ES, FI, GB, GD, GE, GH, GM, HR, HU, ID, IL, IN, IS, JP, KE, KG, KP, KR, KZ, LC, LK, LR, LS, LT, LU, LV, MA, MD, MG, MK, MN, MW, MX, MZ, NA, NI, NO, NZ, OM, PG, PH, PL, PT, RO, RU, SC, SD, SE, SG, SK, SL, SM, SY, TJ, TM, TN, TR, TT, TZ, UA, UG, US, UZ, VC, VN, YU, ZA, ZM, ZW.
- (84) Designated States (unless otherwise indicated, for every kind of regional protection available): ARIPO (BW, GH, GM, KE, LS, MW, MZ, NA, SD, SL, SZ, TZ, UG, ZM, ZW), Eurasian (AM, AZ, BY, KG, KZ, MD, RU, TJ, TM), European (AT, BE, BG, CH, CY, CZ, DE, DK, EE, ES, FI, FR, GB, GR, HU, IE, IS, IT, LT, LU, MC, NL, PL, PT, RO,

[Continued on next page]

(54) Title: CALIBRATION OF A SURVEYING INSTRUMENT

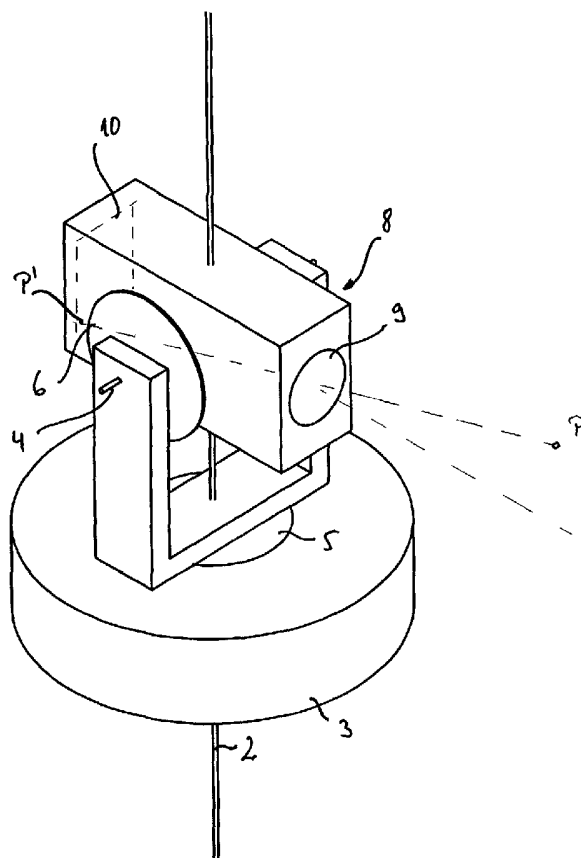

(57) Abstract: A method for calibrating a surveying instrument is disclosed the survey instrument comprising a base element (3) and a camera with an image sensor (10), the camera being rotatable about a vertical axis (2) fixed with respect to said base element and being rotatable about a tilting axis (4), the tilting axis being rotated about the vertical axis with rotation of the camera about the vertical axis, In the method, data associated with calibration points (P) and images (P1) of the calibration points on the image sensor captured in different faces are used, the data for each of said calibration points comprising distance data and the data for each of the images of each said calibration point comprising image position data and orientation data. Further, on the basis of the distance data for each of the calibration points and the image position and orientation data for each of the images of the calibration points the surveying instrument is calibrated simultaneously taking into account at least one optical property of camera and at least one of the relative orientation of the vertical axis and the tilting axis and the orientation of the camera relative to one of the base element, the vertical axis and the tilting axis.

WO 2005/059473 A3



SE, SI, SK, TR), OAPI (BF, BJ, CF, CG, CI, CM, GA, GN,  
GQ, GW, ML, MR, NE, SN, TD, TG).

**(88) Date of publication of the international search report:**  
1 December 2005

**Published:**

— with international search report

*For two-letter codes and other abbreviations, refer to the "Guidance Notes on Codes and Abbreviations" appearing at the beginning of each regular issue of the PCT Gazette.*

# INTERNATIONAL SEARCH REPORT

International Application No  
PCT/EP2004/014365

**A. CLASSIFICATION OF SUBJECT MATTER**  
IPC 7 G01C15/00

According to International Patent Classification (IPC) or to both national classification and IPC

**B. FIELDS SEARCHED**

Minimum documentation searched (classification system followed by classification symbols)  
IPC 7 G01C

Documentation searched other than minimum documentation to the extent that such documents are included in the fields searched

Electronic data base consulted during the international search (name of data base and, where practical, search terms used)  
EPO-Internal, WPI Data, IBM-TDB, INSPEC, PAJ

**C. DOCUMENTS CONSIDERED TO BE RELEVANT**

Category °	Citation of document, with indication, where appropriate, of the relevant passages	Relevant to claim No.
A	Y. D. HUANG: "Calibration of the Wild P32 Camera using the Camera-ON-Theodolite method" PHOTOGRAMMETRIC RECORD, vol. 16, no. 91, April 1998 (1998-04), pages 97-104, XP009044993 cited in the application	1,2,20, 23,24
X	page 98, last paragraph - page 101, paragraph 3; figures 1,2; table II -----	27
A	Y. D. HUANG; I. HARLEY: "CCD camera calibration without a control field" INTERNATIONAL ARCHIVES OF PHOTOGRAMMETRY AND REMOTE SENSING, vol. 28, no. 5, August 1990 (1990-08), pages 1028-1034, XP009045166	1,2,20, 23,24
X	sections 2.1, 2.2 and 4.1; figures ----- -/--	27

Further documents are listed in the continuation of box C.

Patent family members are listed in annex.

° Special categories of cited documents :

- "A" document defining the general state of the art which is not considered to be of particular relevance
- "E" earlier document but published on or after the international filing date
- "L" document which may throw doubts on priority claim(s) or which is cited to establish the publication date of another citation or other special reason (as specified)
- "O" document referring to an oral disclosure, use, exhibition or other means
- "P" document published prior to the international filing date but later than the priority date claimed

- "T" later document published after the international filing date or priority date and not in conflict with the application but cited to understand the principle or theory underlying the invention
- "X" document of particular relevance; the claimed invention cannot be considered novel or cannot be considered to involve an inventive step when the document is taken alone
- "Y" document of particular relevance; the claimed invention cannot be considered to involve an inventive step when the document is combined with one or more other such documents, such combination being obvious to a person skilled in the art.
- "&" document member of the same patent family

Date of the actual completion of the international search

4 April 2005

Date of mailing of the international search report

22 07 2005

Name and mailing address of the ISA

European Patent Office, P.B. 5818 Patentlaan 2  
NL - 2280 HV Rijswijk  
Tel. (+31-70) 340-2040, Tx. 31 651 epo nl,  
Fax: (+31-70) 340-3016

Authorized officer

Jakob, C

INTERNATIONAL SEARCH REPORT

International Application No  
PCT/EP2004/014365

C.(Continuation) DOCUMENTS CONSIDERED TO BE RELEVANT		
Category °	Citation of document, with indication, where appropriate, of the relevant passages	Relevant to claim No.
A	Z. ZHANG, S. ZHENG, Z. ZHAN: "Photo Total Station System an Integration of Metric Digital Camera and Total Station" PROCEEDINGS OF 6TH CONFERENCE ON OPTICAL 3-D MEASUREMENT TECHNIQUES, 22-25 SEPTEMBER 2003, ZURICH, vol. I, September 2003 (2003-09), pages 176-182, XP009045199	1,2,20, 23,24
X	sections 2 and 3 on pages 177-179 -----	27

INTERNATIONAL SEARCH REPORT

International application No.  
PCT/EP2004/014365

**Box II Observations where certain claims were found unsearchable (Continuation of item 2 of first sheet)**

This International Search Report has not been established in respect of certain claims under Article 17(2)(a) for the following reasons:

1.  Claims Nos.:  
because they relate to subject matter not required to be searched by this Authority, namely:
  
2.  Claims Nos.:  
because they relate to parts of the International Application that do not comply with the prescribed requirements to such an extent that no meaningful International Search can be carried out, specifically:
  
3.  Claims Nos.:  
because they are dependent claims and are not drafted in accordance with the second and third sentences of Rule 6.4(a).

**Box III Observations where unity of invention is lacking (Continuation of item 3 of first sheet)**

This International Searching Authority found multiple inventions in this international application, as follows:

see additional sheet

1.  As all required additional search fees were timely paid by the applicant, this International Search Report covers all searchable claims.
  
2.  As all searchable claims could be searched without effort justifying an additional fee, this Authority did not invite payment of any additional fee.
  
3.  As only some of the required additional search fees were timely paid by the applicant, this International Search Report covers only those claims for which fees were paid, specifically claims Nos.:
  
4.  No required additional search fees were timely paid by the applicant. Consequently, this International Search Report is restricted to the invention first mentioned in the claims; it is covered by claims Nos.:

1-27

**Remark on Protest**

- The additional search fees were accompanied by the applicant's protest.
- No protest accompanied the payment of additional search fees.

FURTHER INFORMATION CONTINUED FROM PCT/ISA/ 210

This International Searching Authority found multiple (groups of) inventions in this international application, as follows:

1. claims: 1-27

calibrating a surveying instrument having a camera with an image sensor,  
the camera being rotatable about a vertical and a tilting axis,  
using calibration point distance data, calibration images captured in different faces and associated data and taking into account an optical property of the camera.

---

2. claim: 28

a surveying instrument having a camera with an image sensor, and a display for displaying images and a mark indicating a sighting axis defined by the projection center and the intersection point of the tilting axis and the vertical axis.

---

3. claims: 29, 30

calculating a direction from the coordinate system of a surveying instrument having a camera rotatable about a vertical and a tilting axis to an object point by using a direction obtained with a camera model and a transformation model and the distance of the object point to the instrument coordinate system.

---