



(19) **United States**

(12) **Patent Application Publication**

Tessier et al.

(10) **Pub. No.: US 2005/0194456 A1**

(43) **Pub. Date:**

**Sep. 8, 2005**

(54) **WIRELESS CONTROLLER WITH GATEWAY**

(76) Inventors: **Patrick C. Tessier**, Oakdale, MN (US);  
**Jeffrey S. Hartzler**, Minnetonka, MN (US)

Correspondence Address:  
**Honeywell International, Inc.**  
**Patent Services Group**  
**101 Columbia Road**  
**Morristown, NJ 07962 (US)**

(21) Appl. No.: **10/792,027**

(22) Filed: **Mar. 2, 2004**

**Publication Classification**

(51) **Int. Cl.<sup>7</sup> ..... G05D 23/00**

(52) **U.S. Cl. .... 236/51**

(57) **ABSTRACT**

Remote control of energy consumption is realized using a readily installable, flexible approach. According to an

example embodiment of the present invention, a remote source communicates with a wireless controller for executing energy usage control. The remote source sends signals to the wireless controller via a gateway located near or, in one implementation, forming part of the wireless controller. In response to the signals, the wireless controller sets control settings for operating one or more of a variety of equipment types, such as a furnace, air conditioner, water heater or heat pump. With this approach, wired connections from the gateway to energy-consuming equipment do not necessarily need to be made in order to effect remote energy-consumption control. For instance, when used in connection with a controller wired to the energy-consuming equipment, the gateway need only communicate wirelessly with the controller and does not necessarily need to be coupled to the energy-consuming equipment. In addition, access to the energy-consuming equipment for establishing remote energy control is not necessary; rather, the remote energy control can be effected by accessing user-friendly locations, such as those where thermostats and other controllers are typically located.

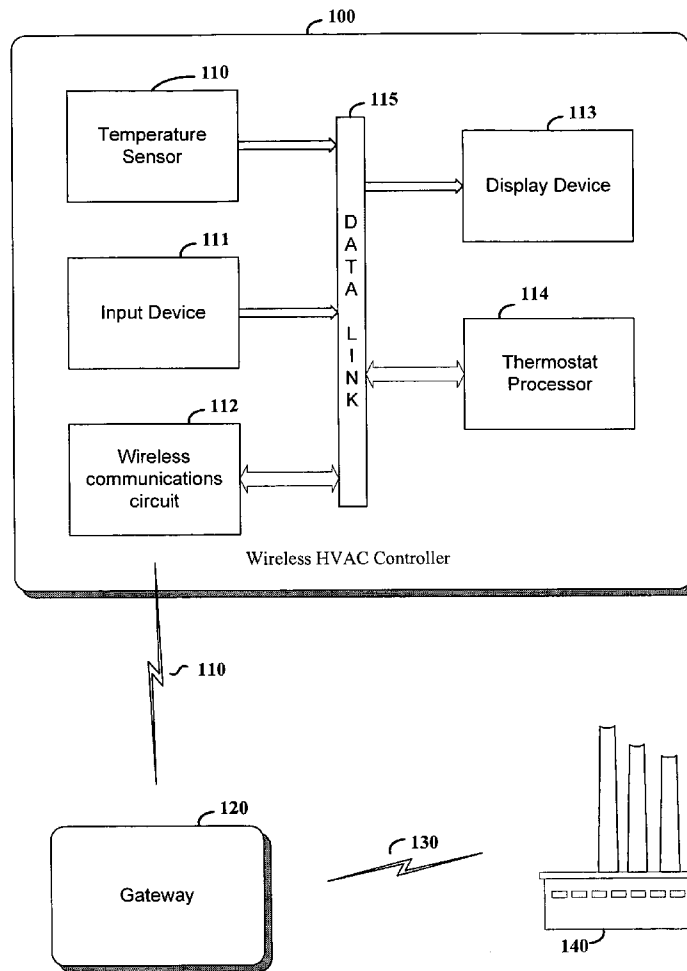

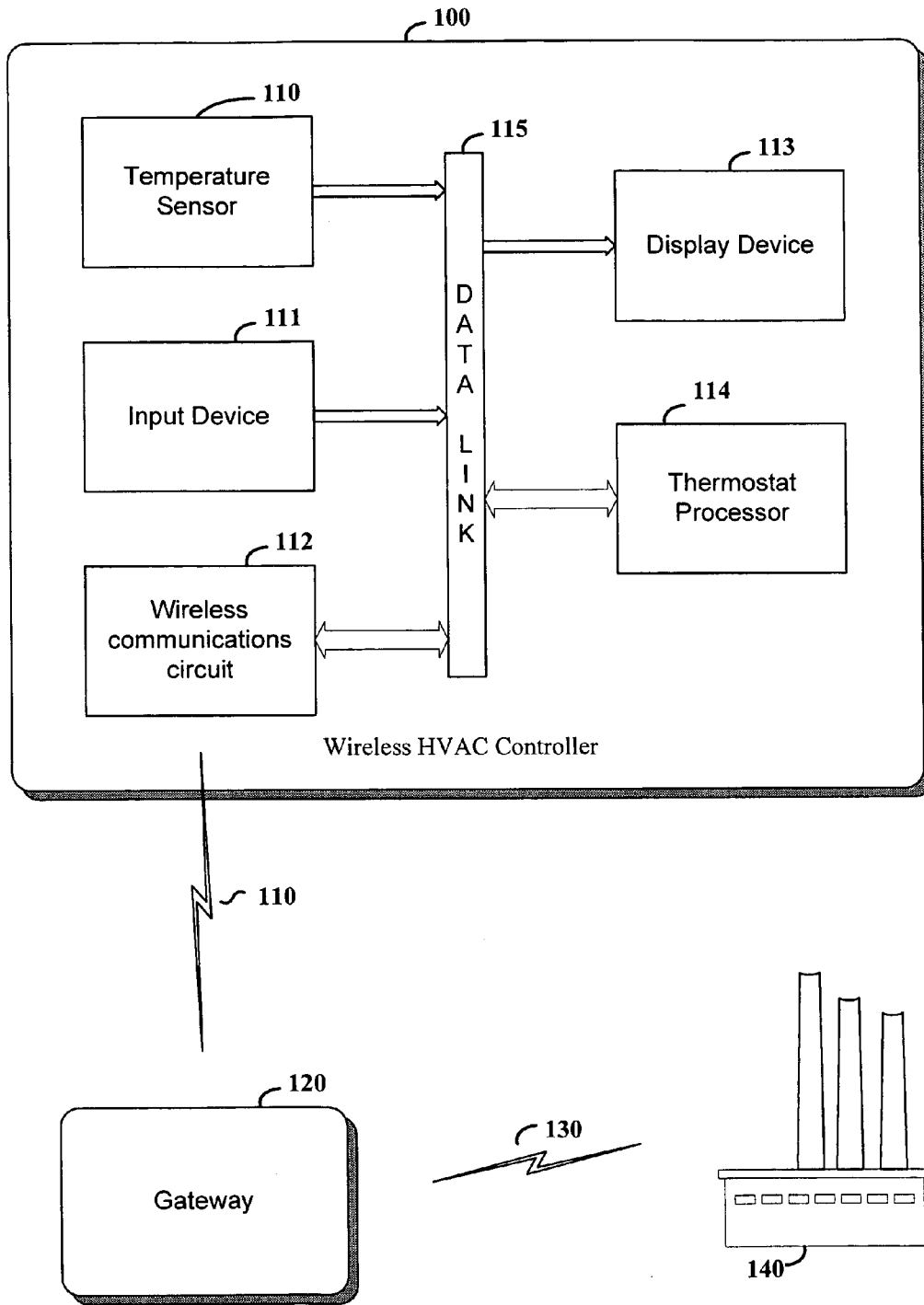

FIG. 1

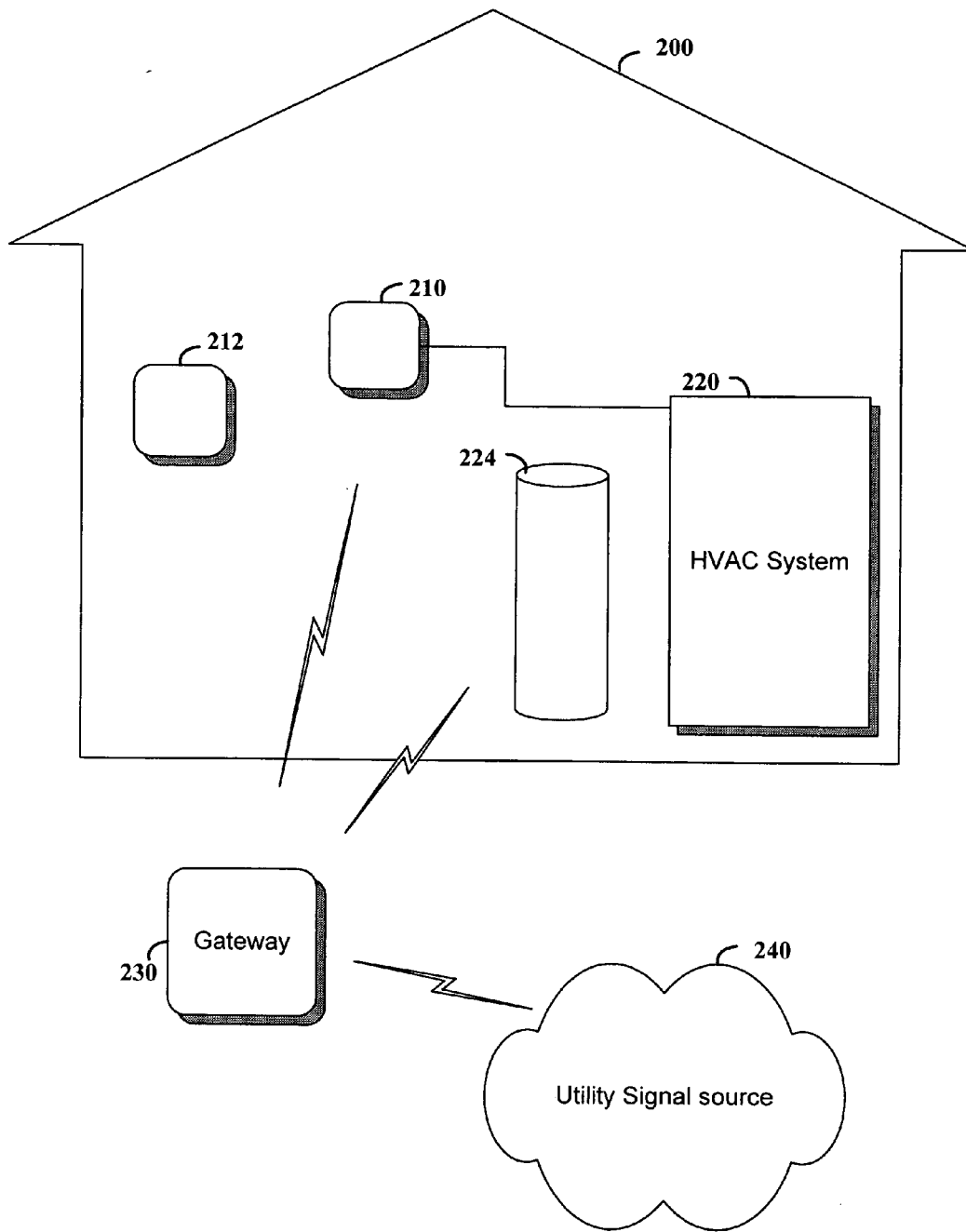

FIG. 2

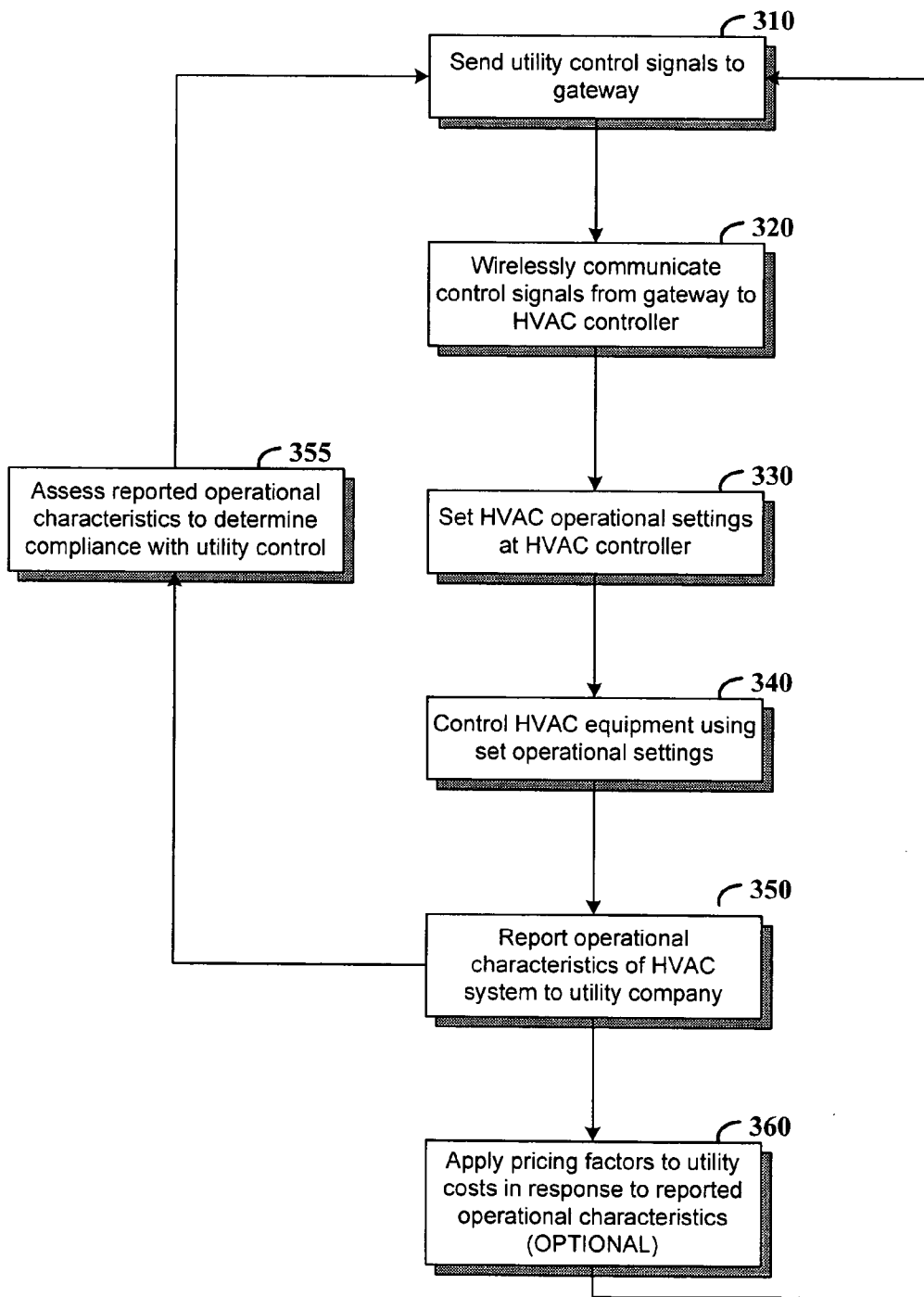
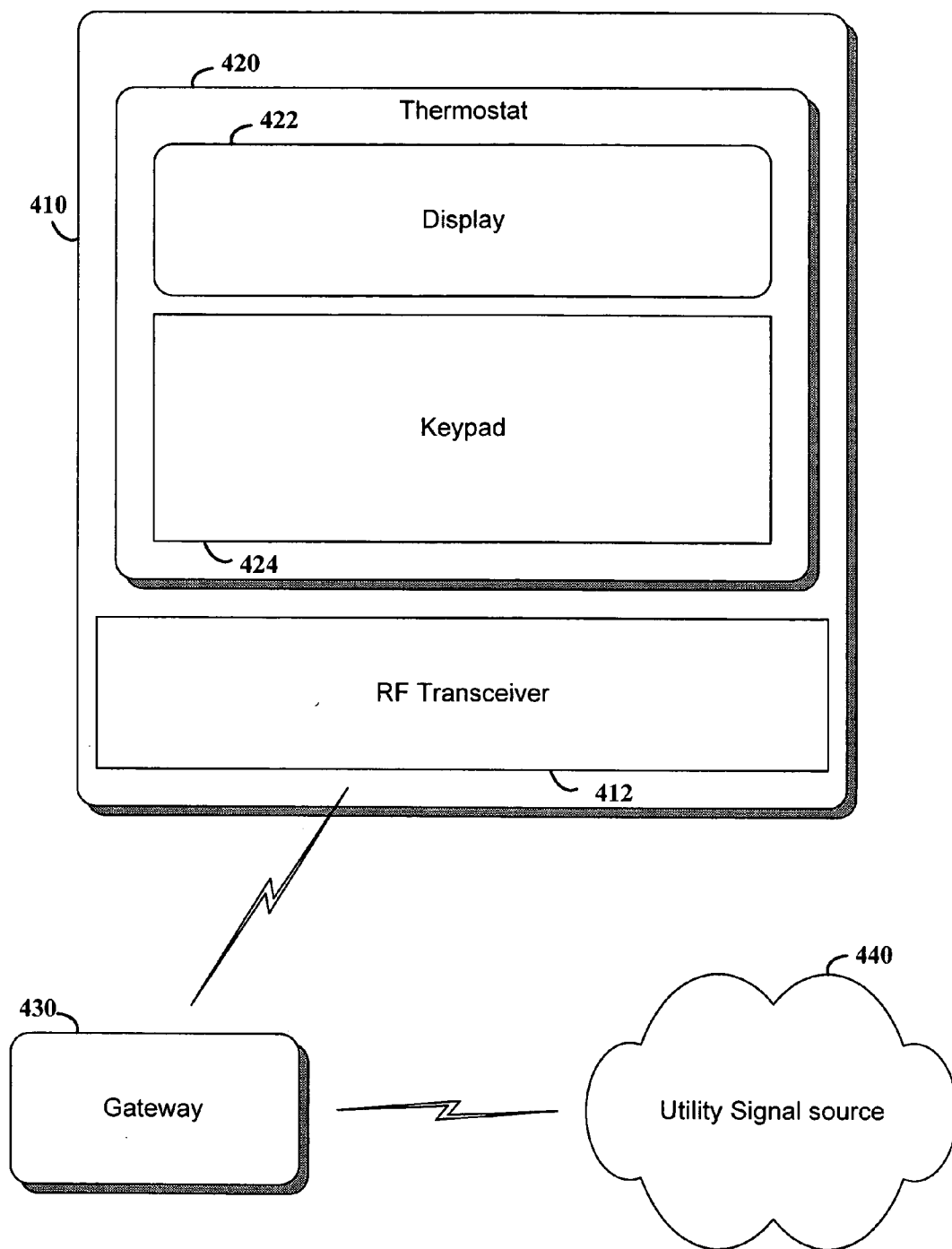
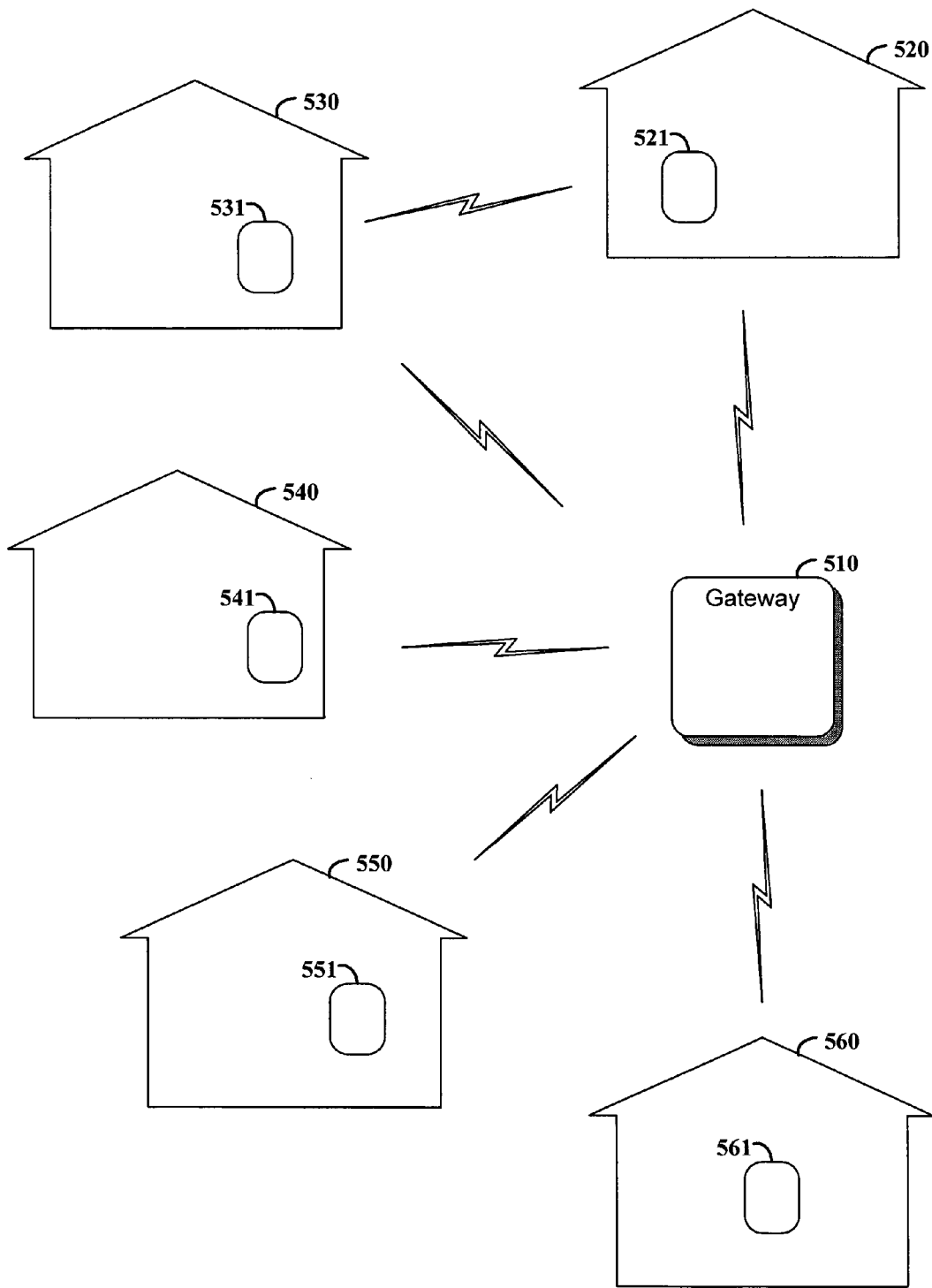

FIG. 3



**FIG. 4**



**FIG. 5**

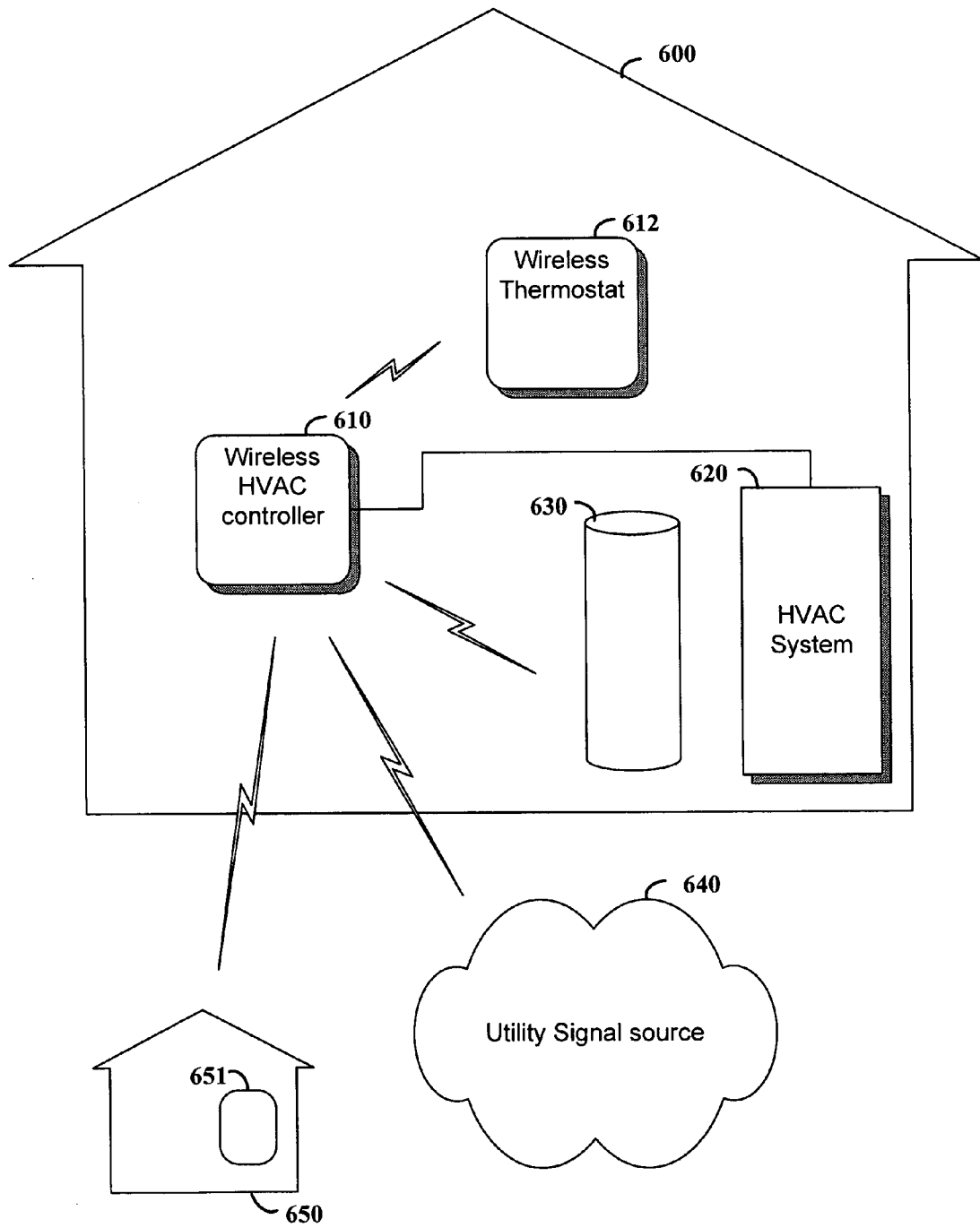
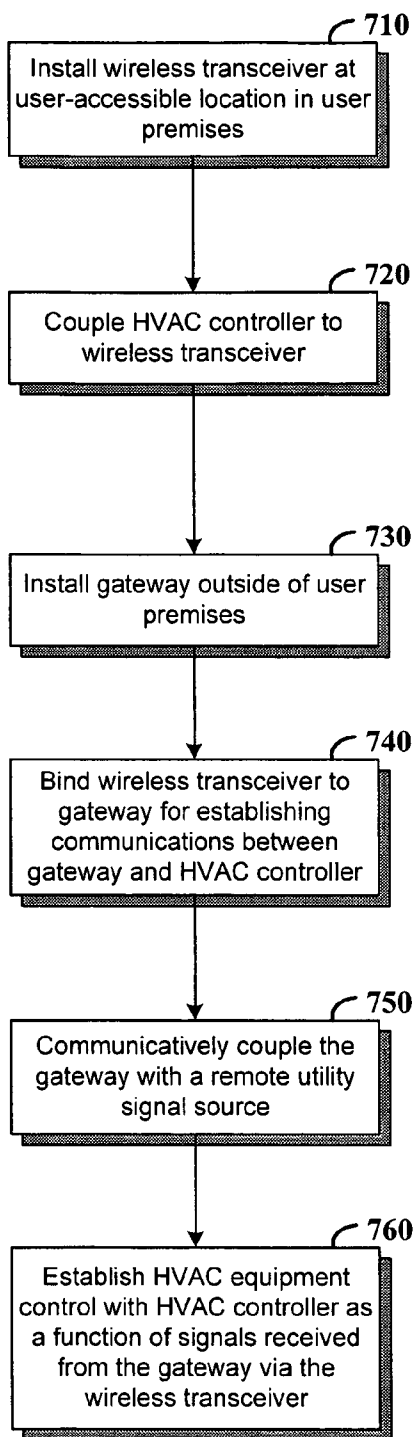

FIG. 6



**FIG. 7**



## WIRELESS CONTROLLER WITH GATEWAY

### FIELD OF THE INVENTION

[0001] This invention relates in general to utility consumption control, and more particularly to a controller with a local gateway for executing remote utility consumption control.

### BACKGROUND OF THE INVENTION

[0002] Electronic controllers such as thermostats and fan controls are used to control a variety of heating, ventilating and air conditioning (HVAC) equipment as well as other fuel and power consumption equipment. Furnaces, heat pumps, gas burners, water heaters, electric radiators, water radiators, air conditioners, chillers, fans, blowers and humidity controllers are example types of equipment for which electronic controllers are used. These equipment types are often grouped into the category called "HVAC." Controllers for these equipment types are often located in user-accessible locations that are remote from the controlled equipment. For instance, thermostats are commonly placed on interior walls of a dwelling and located remotely from controlled HVAC equipment that is located, for example, in a utility room or a basement. Typical controllers accept user inputs received via keypads or other input devices and use the inputs to generate control outputs for controlling HVAC equipment and other equipment types. Often, the controller also includes and/or is coupled to a temperature sensor and accepts temperature set point inputs. Control signals are sent to HVAC equipment as a function of the set point inputs and an output from the temperature sensor. For instance, when in a furnace system is in heating mode, a signal calling for heat is sent to the furnace in response to sensing that a temperature that is lower than a set point.

[0003] Residential and industrial HVAC type applications rely upon utility providers to supply the electricity and/or fuel required for operation of HVAC equipment. One challenge confronting such utility providers today is the great variance in total demand on a network between peak and off-peak times during the day. Peak demand periods are intervals of very high demand on power generating equipment or on fuel supply where load shedding may be necessary to maintain proper service to the network. These periods occur, for example, during hot summer days occasioned by the wide spread simultaneous usage of electrical air conditioning devices or during the coldest winter months in areas where a strong heating load is required.

[0004] Another characteristic of utility supply and usage (e.g., electric and/or fuel usage) is the variance in cost of the utility being supplied under different conditions. For instance the cost of providing a utility can increase during peak supply times due to a variety of conditions. The efficiency of power generation or fuel supply equipment, limitations in a utility distribution network, economical cost/demand relationships and other factors all affect utility costs. In this regard, certain customers are amenable to relinquishing the control of their utility requirements as a function of cost, and certain utilities preferably charge for services as a function of the time at which usage occurs.

[0005] Several basic strategies and devices have been utilized for controlling HVAC equipment in order to limit the peak power demand on the power and fuel generating

capacity of utility companies. One such approach involves sending signals from a utility to disconnect or interrupt the use of certain selected HVAC loads (e.g., air conditioning compressors) when demand has reached a certain point. Another approach involves assuming control of a setpoint function of a thermostat associated with HVAC equipment. The overriding control functions cause the setpoint to change to use less power or fuel at times of high demand or high unit cost.

[0006] Such approaches can be implemented for reducing power or fuel consumption during peak demand times or other times when the reduction in utility usage is desirable, such as during periods when the power and/or fuel cost per unit is high. However, typical energy-reduction implementations involve the installation of control equipment at the HVAC equipment, such as by directly coupling a controller to a furnace. This installation of control equipment has often required that skilled technicians physically install the control equipment at its location, which also often required that the technician have access to customer environment (e.g., access to a customer's home). In addition, typically installations of this type often require a significant amount of technician time, which can be expensive.

[0007] Accordingly, the above-discussed issues have been challenging to the implementation of a variety of devices and systems involving climate control and particularly involving the control of HVAC and other equipment in response to price and/or demand conditions.

### SUMMARY OF THE INVENTION

[0008] To address the issues described above and others that will become apparent upon reading and understanding the present specification, the present invention discloses a system, apparatus and method for addressing challenges related to equipment control and related controller installation.

[0009] In accordance with one example embodiment of the invention, a wireless communications device is configured and arranged to control energy-consuming equipment in response to both local control inputs and wireless control inputs received from a gateway. The local control inputs are received, e.g., at the wireless communications device using an input device such as a keypad as is typically used for thermostats. The wireless control inputs originate from a location remote from the gateway, such as a utility provider that configures the control information as a function of one or more of a variety of characteristics or an end-user sending control inputs via the gateway to remotely control the energy-consuming equipment. With this approach, the control of local energy-consuming devices can be effected without necessarily coupling a controller directly to the energy-consuming devices and, in some instances, without necessarily accessing premises at which the energy is consumed. For instance, by wirelessly communicating between a utility gateway and a thermostat wired to an HVAC system, the gateway does not necessarily have to directly couple to the HVAC system.

[0010] In a more particular example embodiment of the present invention, the wireless communications device includes a thermostat and circuitry for providing control signals to HVAC equipment using, for example, conventional wired connections commonly used in thermostat

applications. The thermostat includes a keypad type device for receiving user inputs at the thermostat for use in controlling the climate in an environment. A wireless transceiver at the wireless communications device communicates with the gateway for passing signals between the gateway and the thermostat, with signals received from the gateway being used to control the HVAC equipment. As with the example embodiment discussed above, this approach facilitates the control of HVAC equipment with control signals sent via the gateway and without necessarily coupling the gateway directly to the HVAC equipment.

#### BRIEF DESCRIPTION OF THE DRAWINGS

[0011] Various example embodiments of the invention are described in connection with the embodiments illustrated in the following diagrams.

[0012] **FIG. 1** is an HVAC controller adapted to wirelessly communicate with a gateway for controlling HVAC equipment, according to an example embodiment of the present invention;

[0013] **FIG. 2** is system showing a user dwelling with an HVAC system and controller responsive to a utility gateway, according to another example embodiment of the present invention;

[0014] **FIG. 3** is a flow diagram for controlling an HVAC system with signals sent via a gateway, according to another example embodiment of the present invention;

[0015] **FIG. 4** is a radio frequency (RF) thermostat base arrangement adapted to couple to a thermostat and to wirelessly communicate with a gateway for passing signals between the gateway and the thermostat, according to another example embodiment of the present invention;

[0016] **FIG. 5** shows a system including a gateway adapted to communicatively couple to a plurality of thermostats located in different environments and to pass signals between a utility signal source and the plurality of thermostats, according to another example embodiment of the present invention;

[0017] **FIG. 6** is an HVAC system controller configured and arranged to wirelessly communicate directly with a utility provider, according to another example embodiment of the present invention; and

[0018] **FIG. 7** is a flow diagram for an installation approach involving remote utility control, according to another example embodiment of the present invention.

#### DETAILED DESCRIPTION OF THE INVENTION

[0019] In the following description, reference is made to the accompanying drawings which form a part hereof, and in which is shown by way of illustration particular embodiments in which the invention may be practiced. It is to be understood that other embodiments may be utilized, as structural and operational changes may be made without departing from the scope of the present invention.

[0020] According to an example embodiment of the present invention, a system controller installed, e.g., at a user-accessible controller location wirelessly communicates with a utility gateway for receiving control signals facilitat-

ing external utility control of an electrical and/or fuel-consuming system. The gateway responds to input received from a utility company source by wirelessly sending a control-type signal to the system controller. The system controller responds to the control-type signal by controlling the operation of equipment such as a furnace, air conditioner or water heater, for instance by altering power and/or fuel consumption thereof. With this approach, utility companies can effect control of a local system, such as a residential or commercial HVAC system, without necessarily having to communicate directly with equipment that uses electricity or fuel supplied by the utility company. In addition, this control approach is effected via a system controller, removing any necessity to access the equipment being controlled for installation purposes or to install an interface controller at the equipment being controlled.

[0021] The gateway communicates with the utility company using one or more of a variety of types of communications and communications systems. For instance, signals sent to the gateway via telephone lines, wireless telephony systems, paging systems, power lines and the Internet can all be used by the gateway to generate a wireless control-type signal. The gateway responds to signals received from the utility company, for example, by either directly relaying the signal or processing the signal to create another type of signal that is sent to the system controller. The gateway also communicates information received from the system controller to the utility company, for example to allow the utility company to monitor the implementation of utility inputs.

[0022] In some instances, different types of communications are used for different types of signals communicated via the gateway. For example, a simple paging signal may be broadcast to a plurality of gateways to initiate an energy-reducing event, with each gateway correspondingly communicating to system controllers using a local radio frequency (RF) signal. Outputs from system controllers communicated by their associated gateways to the utility company may also use more than one communication type, for example with an RF signal between the system controllers and a gateway, and a corresponding wired communication between the gateway and the utility company.

[0023] The system controller is communicatively coupled to the equipment being controlled using one or more types of communications links, such as those typically implemented with conventional controllers. For instance, the system controller may include a wall-mounted thermostat wired to a furnace and/or air conditioner and adapted to receive user inputs (i.e., temperature set points) for controlling the system. The wall-mounted thermostat may include, for example, an all-in-one unit with the thermostat being adapted to wirelessly communicate with the gateway, or a thermostat connected to a base having wireless capabilities, for example, as discussed further in connection with **FIG. 4**.

[0024] The system controller also sends wireless signals including information about the equipment being controlled to the gateway. For instance, operational characteristics of an HVAC system can be sent to the gateway and relayed to the utility company to ensure that users do not circumvent the utility company's control effected via the gateway. Such circumvention may be used, in the absence of such monitoring, to override a reduction in energy consumption mandated by the utility company. In addition, information for

statistical monitoring of operational characteristics such as temperature set point and others can be sent to the gateway and relayed to the utility company. When time of usage is related to pricing, information regarding the time of consumption can also be sent to the gateway and relayed to the utility company for use in pricing the consumption. These and other informative signals are used for a variety of applications and control implementations involving the wireless gateway and system controller arrangement.

[0025] FIG. 1 shows an HVAC controller 100 that communicates with a gateway 120 via a wireless link 110 to control an HVAC system, according to another example embodiment of the present invention. The HVAC controller 100 is located in a user-accessible position, typically within a dwelling or other environment in which an HVAC system operates. For instance, the HVAC controller 100 can be used to replace a conventional wall-mounted thermostat. In this regard, the HVAC controller 100 can be powered either by wiring to a power supply (e.g., as would be done with a conventional thermostat) or with a battery. When used in place of a conventional wired thermostat, communications between the HVAC controller 100 and an HVAC system use the conventional thermostat wiring that couples the HVAC controller to an internal control circuit for the HVAC system (e.g., a printed circuit board enclosed in a furnace). The gateway 120 communicates with a utility company 140 via a communications link 130 (e.g., telephone line, power line or wireless link) for receiving control signals from and for sending information to the utility company.

[0026] The HVAC controller 100 includes a wireless communications circuit 112, such as an RF transceiver adapted to communicate between coupled a data link 115 (e.g., local bus) and the gateway 120. The communications circuit 112 is matched with a similar communications circuit at the gateway 120 (e.g., with both employing matched RF transceivers). When the HVAC controller 100 is battery powered, the wireless communications circuit 112 is optionally adapted to enter a low-power mode when not communicating. A thermostat processor 114 (e.g., a microcontroller) processes information received via the data link 115 from an input device 111, temperature sensor 110 and the wireless communications circuit 112. Information including HVAC control information is displayed at a display device 113 as a function of the thermostat processor 114. The thermostat processor 114 further sends information via the data link 115 to the wireless communications circuit 112 for communicating to the utility company 140 (via communications links 110 and 130 and gateway 120). Communications from the HVAC controller 100 to the gateway 120 may include information regarding characteristics of user intervention, such as inputs to the HVAC controller to override energy-saving events, selections made at the HVAC controller and others.

[0027] The thermostat processor 114 typically responds to user inputs (e.g., temperature set points and other HVAC control selections received at the input device 111) and to temperature signals received from the temperature sensor 110 by sending a control signal to an HVAC system. User inputs including configuration information can be stored and used by the thermostat processor to automatically respond to utility control signals, for example by comparing the utility control signals to stored inputs relating to participation in an energy-saving event. Under high demand, during a price-

controlled event or in other instances warranting external utility control, the utility company 140 sends utility control signals to the HVAC controller 100. In response, the thermostat processor 114 sends control signals to the HVAC system as a function of the utility control signals and/or other programmed settings or inputs. For instance, in response to high electrical usage conditions, the utility company 140 may send a utility control signal to the HVAC controller 100 that instructs the HVAC controller to reduce power usage. In response to the utility control signal, the thermostat processor 114 adjusts control settings for controlling the HVAC system to reduce energy load. This adjustment may include one or more of a variety of responses, such as altering a temperature set point input received via the input device 111 or cycling the HVAC equipment to reduce its operating time. In addition, adjusting control settings for the HVAC system may also include using other data, such as user input data, price tier data or time of day data, when determining or identifying a particular control setting. Depending upon the implementation, circuit configuration and available utility company programs for customer participation, various levels of user control and HVAC controller operation are executed in this manner.

[0028] When the high utility demand conditions have passed, control of the HVAC system is released back to the HVAC controller 110. In one implementation, the utility company 140 sends a signal to the HVAC controller 110 to release control of the HVAC system back to the control established by user inputs at input device 111. In another implementation, the utility control signal sent to the HVAC controller 100 includes timing information that sets an interval during which the utility control is to take place. When the timing interval has passed, control is automatically released to the HVAC controller 110.

[0029] In some implementations, the wireless communications circuit 112 has a unique identity used in the transmission of signals to the gateway 120 for identifying the wireless communications circuit (and, correspondingly, the HVAC controller 100 and system that it controls). For instance, the gateway 120 may bind to the HVAC controller 100 by polling for the unique identity of the wireless communications circuit 112 during an initialization event where the unique identity is sent to the gateway. During subsequent communications, the gateway 120 uses the unique identity to direct signals to the HVAC controller 100; if the unique identity is not referenced in a particular signal, the wireless communications circuit 112 can ignore the signal. The unique identity can also be used by the gateway 120 to identify a particular HVAC controller 100 sending a signal, for example, when reporting information to the utility company 140. Optionally, the gateway 120 assigns an identifier to each wireless communications circuit to which it binds (e.g., after an initialization event as discussed above) and subsequently uses the assigned identifier to exclusively communicate with the wireless communications circuit. The use of such a unique identity and/or assigned identifier facilitates accurate communications in an arrangement with more than one wireless device, such as more than one HVAC controller 100.

[0030] In another implementation, the HVAC controller 100 is adapted to respond to pre-heating or pre-cooling control signals sent by the utility company 140 in advance of a high-demand event. The HVAC controller 100 pre-heats

or pre-cools an environment to reduce the effect of the high-demand event in response to the control signals. For instance, when the HVAC controller **100** is controlling heating equipment (e.g., a furnace, electric heater or water heater), the utility company **140** sends a pre-heating signal to the HVAC controller prior to a high fuel or electrical demand event. In response, the HVAC controller **100** increases the amount of heat supplied to increase the temperature in the environment that the HVAC controller serves. When the high-demand event occurs, the utility company **140** sends a signal to the HVAC controller **100** to reduce the heating load exerted on the utility company. Since the environment has been pre-heated, the drop in temperature in the environment relative to a temperature set point is reduced.

[0031] In another implementation, the HVAC controller **100** is adapted to display information at the display device **113** to inform users of an energy-saving event. In response, users can selectively chose to participate in the energy saving event via the input device **111**, with the selection being wirelessly communicated to the gateway **120** via the wireless communications link **110**. The utility company **140** is notified of the participation and responds by sending a signal to the HVAC controller **100** via the gateway **120** to reduce power consumption during the energy saving event.

[0032] In another implementation, the HVAC controller **100** is adapted to display pricing tiers for energy usage. For example, the utility company **140** may provide price-per-unit information to the HVAC controller **100** for different times and/or amounts of usage. The price tier information is displayed at the display device **113** and users can respond via the input device **111** by selecting a price tier to participate in. Alternatively (or in addition), price tier acceptance information is stored at the HVAC controller **100** and, in response to price tier information provided by the utility company **140**, the stored price tier acceptance information is used to automatically accept and participate in the price tier. With these approaches, users can selectively participate in energy-saving events offered by the utility company **140**.

[0033] FIG. 2 shows a user dwelling **200** (e.g., a house) having an HVAC system **220** and a water heater **224** both controlled with signals sent by a wireless gateway **230**, according to another example embodiment of the present invention. The gateway **230** communicates with a utility (or other) signal source **240**, such as a radio frequency (RF) broadcast tower, the Internet or a telephone line for sending and receiving signals as described in connection with the gateway **120** of FIG. 1. A wireless thermostat **210**, similar to the wireless HVAC controller **100** of FIG. 1, receives wireless information from the gateway **230** for controlling the HVAC system **220**. For example, during a high-demand period, signals sent from the utility signal source **240** to the gateway **230** to reduce energy consumption (power and/or fuel) at the HVAC system **220** are passed to the wireless thermostat **210**. In response, the wireless thermostat **210** uses inputs received from the gateway **230** to override inputs received from users at the wireless thermostat for controlling the operation of the HVAC system **220**. The wireless thermostat **210** also communicates characteristics of the HVAC system **220** to the gateway **230**, for example to facilitate the monitoring of user inputs at the wireless thermostat or operational characteristics of the HVAC system **220**.

[0034] The water heater **224** is communicatively coupled to the gateway **230** via either a wired or wireless connection and thereby receives control signals from the utility signal source **240**. In one implementation, the water heater **224** includes a wireless controller similar to the controller **100** shown in FIG. 1 and communicates wirelessly with the gateway **230**. In response to wireless signals received from the gateway **230** and to user inputs received at the controller at the water heater **224**, the controller adjusts the operation of the water heater. The adjustment may, for example, include lowering a temperature setting during an energy-saving event or raising a temperature setting to pre-heat the water prior to an energy-saving event. User selections made at the water heater **224** and/or operational characteristics thereof are optionally sent to the utility signal source **240** via the gateway **230** for monitoring purposes.

[0035] In a more particular implementation, the dwelling **200** includes two or more wireless thermostats including wireless thermostats **210** and **212**, each adapted to wirelessly communicate with the gateway **230**. Each wireless thermostat is selectively controlled by signals received from the gateway **230** as a function of programming at the gateway. For example, the gateway **230** can be programmed to control both wireless thermostats **210** and **212** similarly, with wireless signals sent from the gateway being received by both thermostats.

[0036] Alternately, the wireless thermostats **210** and **212** can be programmed differently for different control approaches. For instance, when a user has different heating or cooling zones in the dwelling **200**, he or she may be more amenable to having certain zones controlled by signals received via the gateway **230**. Heating or cooling zones for which the maintenance of predefined temperatures is not as important, such as a basement or garage, may be prime candidates for facilitating energy reduction. In this regard, thermostats that control the temperature in these zones are used to reduce the energy consumption of the HVAC system **220** by adjusting temperature set points in these zones accordingly.

[0037] In another example embodiment of the present invention, a gateway facilitates remote control of energy consuming equipment in an environment by users of the environment. Referring to FIG. 2 by way of example, a user owner of the dwelling **200** sends control signals from the signal source **240** to the gateway **230** (e.g., with the signal source **240** including a user access source, such as the Internet, via which the user enters control signals). The gateway **230** sends wireless information to the wireless thermostat **210**, which controls the HVAC system **220** in response thereto. With this approach, users can remotely control HVAC equipment or other equipment via the gateway, either in addition to or separate from any utility-based control.

[0038] FIG. 3 shows a flow diagram of an approach for controlling an HVAC system with remote utility signals sent through a wireless gateway, according to another example embodiment of the present invention. The approach shown in FIG. 3 may be implemented, for example, with other embodiments discussed herein such as the controller shown in FIG. 1 and/or the approach shown in FIG. 2. At block **310**, utility control signals are sent to a local gateway located within wireless transmission range of a wireless controller

for HVAC equipment. At block **320**, the gateway wirelessly communicates control signals to a wireless HVAC controller, for example, by directly relaying control signals received at block **310** or by processing the control signals to generate new control signals for the wireless HVAC controller.

[**0039**] At block **330**, HVAC operational settings are set at the HVAC controller in response to the control signals, which are selected to achieve one or more of a variety of control characteristics. For instance, during peak load times, control signals sent from the utility company can be selected to set the HVAC controller to override and/or work with user inputs and to operate the HVAC system in a reduced consumption mode. Once the peak load time has passed, control signals indicating so and sent from the utility company are used to set the HVAC controller to control the HVAC system as a function of user inputs received at the HVAC controller. At block **340**, these operational settings set in response to the control signals at the HVAC controller are used to control HVAC equipment, for example, by supplying control inputs to the equipment from the HVAC controller. With this approach, the HVAC equipment is remotely controlled from a utility company without necessarily accessing the HVAC equipment, facilitating installation of the on-site control capability with the HVAC equipment.

[**0040**] After the HVAC operational settings are set at the HVAC controller, the HVAC controller sends actual operational characteristics to the utility company via the gateway at block **350** to assess the control of the HVAC equipment. The reported operational characteristics are assessed by the utility company at block **355** and used to send additional utility control signals to the gateway at block **310**. A variety of characteristics can be sent to the utility company at block **350** and assessed at block **355**. For example, user selections made at the HVAC controller can be reported back to the utility company to enable active control and participation in energy savings events. Utility control signals sent at block **310** can then be tailored to these user selections. As another example, actual operating conditions of the HVAC equipment as detected at the HVAC controller (e.g., actual runtime characteristics) can be sent to the utility company for monitoring purposes to ensure that users do not circumvent utility control. Other characteristics, such as the actual temperature of the environment at which the HVAC controller resides, can also be reported, assessed and used to send control signals to the gateway. By controlling the HVAC system via the HVAC controller, these and other parameters available at the controller but not typically available at the equipment itself can now be assessed at the utility company. Alternatively, these actual operating conditions can be used for statistical purposes, such as for energy planning and scheduling.

[**0041**] In another implementation, pricing factors are applied to utility costs in response to the reported operational characteristics at block **360**. The pricing factors may include, for example, a time-of-day usage factor or energy saving event factor, wherein costs for the particular utility being used (e.g., electricity or fuel) are assigned as a function of these factors. For instance, if peak load times for electrical power happen during mid-afternoon on hot summer days, the utility company may wish to charge a premium for providing cooling energy during these peak periods. In this regard, operational characteristics of the HVAC system

that are reported at block **350** via the gateway are used to assign a price to a portion of the energy use that falls during this peak period. Characteristics of these pricing factors are optionally reported back to the HVAC controller via the gateway and displayed for viewing by users. This approach is readily implemented, for example, with the approaches discussed above wherein users can selectively participate in energy-saving events and/or make other selections sent from the HVAC controller to the utility company via the gateway.

[**0042**] FIG. 4 is an RF thermostat base arrangement **410** coupled to a thermostat **420** and adapted to pass signals between the gateway and the thermostat, according to another example embodiment of the present invention. The base arrangement **410** includes an RF transceiver **412** and a built-in antenna that wirelessly communicate with the gateway **430**, which in turn communicates with a utility signal source **440**. The thermostat **420** includes a keypad **424** and a display **422** respectively adapted for receiving inputs and for displaying data. The base arrangement **410** couples to the thermostat **420** to apply control inputs thereto and to receive reporting characteristics and/or user selections therefrom. Keypad inputs may include, for example, typical thermostat-type inputs such as temperature set points for time of day and/or day of week, fan control inputs, immediate temperature control inputs and others. In addition, the keypad inputs may include user selections to be communicated to the utility signal source **440**.

[**0043**] Inputs received via the RF transceiver **412** can be used to override user inputs received at the keypad **424** in response to an energy saving event communicated by the utility signal source **440**. For instance, when the thermostat **420** is programmed to be responsive to the utility signal source for reducing energy usage, inputs received at the keypad **424** for establishing temperature set points are overridden to enable the energy saving event to control the thermostat. In addition, the keypad **424** is optionally adapted to enable users to opt out of an energy saving event, which returns control of the thermostat **420** to the user via the keypad **424**. In this instance, the decision to opt out of the event is communicated to the gateway **430**, which sends a corresponding signal to the utility signal source **440** to inform the utility company of the decision. Similarly, the thermostat **420** is optionally programmed to automatically accept or opt out of participation in energy-saving events as a function of characteristics at the thermostat. For instance, the thermostat **420** can be programmed to decline participation in an energy saving event as a function of temperature sensed at the thermostat (e.g., to prevent freezing or overheating).

[**0044**] FIG. 5 shows a utility control system including a gateway **510** adapted to pass signals between a utility signal source and a plurality of thermostats, according to another example embodiment of the present invention. The gateway **510** is located within wireless range of wireless thermostats for each of locations **520**, **530**, **540**, **550** and **560** (e.g., homes, commercial buildings). For example, when used in residential neighborhoods, the gateway **510** can be located on a telephone pole, on the outside of one of a home or other useful location. In response to signals received from a local utility company, the gateway **510** sends a wireless communication to each of the wireless thermostats **521**, **531**, **541**, **551** and **561**. The wireless thermostats respond to the signals from the gateway **510** by controlling HVAC equipment

accordingly, for example as a function of programmed settings at the wireless thermostats or other conditions relative to participation of the locations in utility-based energy consumption control. The wireless thermostats **521-561** also send wireless information to the gateway **510**, which can be used for identifying and monitoring the thermostats as discussed above.

[0045] Communications between the gateway **510** and each wireless thermostat may, for example, use a binding process for establishing proper communications therebetween and for identifying a particular wireless thermostat for sending and/or receiving signals. Such a binding process may involve assigning identifiers to each of the wireless thermostats **521-561**, with the gateway **510** using the individual identifiers, or a range identifier values assigned to the thermostats, for identifying signals from the wireless thermostats. For general information regarding wireless communications and for specific information regarding binding approaches that may be used in connection with one or more example embodiments discussed herein, reference may be made to U.S. patent application Ser. No. \_\_\_\_\_ (HONY.015PA), entitled "Wireless Association Approach and Arrangement Therefor" filed concurrently herewith and fully incorporated herein by reference.

[0046] In one implementation, the gateway **510** sends a single RF signal that is received by each of the wireless thermostats **521-561** in response to signals received from a utility company. The wireless thermostats respond to the RF signal by controlling energy consumption at their respective locations as a function of programming at the particular wireless thermostats. For instance, when a signal received at the gateway **510** from a utility company calls for reduced consumption, the gateway responds by sending a request to reduce consumption to all of the wireless thermostats **521-561**. Each wireless thermostat responds in one or more of a variety of manners, for example, by changing temperature set points to reduce power consumption, by cycling HVAC equipment or by ignoring the gateway if a non-participation mode is set. Operational characteristics of the wireless thermostats and corresponding HVAC systems that each wireless thermostat controls are then sent to the gateway **510** for communication to the utility company. With this approach, individual signals need not necessarily be tailored for each wireless thermostat to which the gateway **510** is communicating. However, feedback from each wireless thermostat in response to the signals can still be individually obtained and identified.

[0047] In another implementation, the gateway **510** is programmed to tailor signals for one or more of the wireless thermostats **521-561**. For example, the signals for a particular wireless thermostat can be tailored to match a particular energy savings plan subscribed to by the location controlled with the wireless thermostat. Using wireless thermostat **521** as an example, user selections made at the wireless thermostat are sent to the gateway **510** and stored for use in establishing utility control, using binding or another approach to control communications between the wireless thermostat and the gateway. These user selections may include, for example, types of energy savings events to participate in, levels of participation (e.g., how much of a reduction in energy usage or how many degrees in temperature set points change when requested) and others. When the gateway **510** receives signals from a utility company, the

signals are processed as a function of the selections stored at the gateway for the wireless thermostat **521**. A signal is then generated for and sent to the wireless thermostat **521** as a function of both the utility company signals and the stored selections. This approach is also applicable, for example, to the use of multiple wireless thermostats in a single environment using an approach similar to that discussed in connection with **FIG. 2** above, with each thermostat having signals tailored specifically for it. In this regard, individual thermostats in a single environment can be selectively controlled.

[0048] In another example embodiment, the wireless thermostat **531** is configured and arranged to relay information between the gateway **510** and other HVAC controllers. For instance, when the gateway **510** receives a signal from a utility company for controlling energy, the signal is passed to the wireless thermostat **531** and correspondingly relayed to the wireless thermostat **521**. Any response of the wireless thermostat **521** is sent to the wireless thermostat **531** and relayed to the gateway **510**. With this approach, utility company based energy control can be effected using fewer gateways, effectively using a relay approach to extend the range of the gateway **510**.

[0049] In another example embodiment, the wireless thermostat **531** includes the gateway **510** and is adapted to communicate directly to a utility signal source. In addition to controlling HVAC equipment in the location **530**, the wireless thermostat **531** also functions as the gateway **510** for the wireless thermostats in locations **520, 540, 550** and **560** (and others within range of the gateway). With this approach, the installation of utility control systems can be simplified. For instance, when installing such a system in a neighborhood including locations **520-560**, a first location subscribing to utility energy control can be fitted with a combined wireless thermostat and gateway. Using location **530** as an example with wireless thermostat **531** including a gateway, subsequent installations in the neighborhood that are within communication range of location **530** are then communicatively coupled to the wireless thermostat **531**. Utility energy control of subsequent installations in locations **520, 540, 550** and **560** is correspondingly effected using the wireless thermostat **531** as a gateway, similar to the approach discussed above using gateway **510** for these locations.

[0050] **FIG. 6** shows a wireless HVAC controller **610** configured and arranged to wirelessly communicate with a utility provider via a utility signal source **640** for controlling equipment at user location **600**, according to another example embodiment of the present invention. The wireless system controller **610** may, for example, be used in connection with the example embodiment discussed in connection with **FIG. 5** wherein the wireless thermostat **531** includes the gateway **510**. The wireless HVAC controller **610** includes a wireless transceiver for communicating with the utility signal source **640** and with additional wireless HVAC controllers including wireless thermostats **612** and **651**, respectively at user locations **600** and **650**. Using binding or another approach, each wireless HVAC controller to be controlled with the wireless HVAC controller **610** is identified for establishing specific communications and reporting characteristics for each wireless HVAC controller back to the utility company. The wireless HVAC controller **610** controls an HVAC system **620** using wired or wireless

connections, for example, as with a conventional thermostat and/or in a manner similar to that discussed in connection with FIG. 1 above.

[0051] A plurality of energy-consuming devices can be controlled with the wireless HVAC controller 610. For instance, a water heater 630 is optionally controlled using the wireless HVAC controller 610 as a gateway, with control signals received from the utility signal source 640 being used to control the water heater. The wireless HVAC controller 610 is coupled to the water heater 630 using a wired or wireless link. In one implementation, the wireless HVAC controller 610 acts effectively as a gateway for communicating with the water heater 630, as discussed above in connection with FIG. 2 and the gateway 230. In another implementation, the wireless HVAC controller 610 also controls the water heater 630, for example in response to user set points input at the wireless HVAC controller.

[0052] FIG. 7 shows an approach for installing and operating an HVAC control system, according to another example embodiment of the present invention. The approach shown in FIG. 7 may be implemented, for example, to install control systems and to facilitate control approaches discussed herein. At block 710, a wireless transceiver is installed at a user-accessible location at a user premises, such as at a wall-mounted thermostat location. At block 720, an HVAC controller such as a thermostat is coupled to the wireless transceiver. A gateway is installed outside of the user premises at block 730, for example on the exterior of a home or on a local utility pole. At block 740, the wireless transceiver is bound to the gateway for establishing communications between the gateway and the HVAC controller. At block 750, the gateway is communicatively coupled with a remote utility signal source, for example simply by powering the gateway and/or by initiating a binding or other recognition-type process. HVAC equipment control is established at block 760 with the HVAC controller as a function of signals received from the gateway via the wireless transceiver. For instance, temperature set points controlled at block 760 can be used to control the corresponding operation of the HVAC equipment via existing wiring to which the HVAC controller is coupled (e.g., at block 720). With this approach, utility-based control of HVAC equipment can be effected using an installation process that is relatively short and does not necessarily require access to HVAC equipment.

[0053] The foregoing description of various example embodiments of the invention has been presented for the purposes of illustration and description. It is not intended to be exhaustive or to limit the invention to the precise form disclosed. Many modifications and variations are possible in light of the above teaching. For example, a wireless controller for a multitude of energy-consuming appliances can be used in place of the controllers described herein (e.g., in place of the HVAC controllers). It is intended that the scope of the invention be limited not with this detailed description, but rather by the claims appended hereto.

What is claimed is:

1. For use with a gateway communicatively coupled to a remote signal source, a local system controller comprising:
  - a user input device;
  - a wireless communication circuit configured and arranged to receive input signals sent from the gateway in

response to the remote signal source and to send signals including information about the local system to the gateway; and

- a control circuit coupled to the user input device and the wireless communication circuit and configured and arranged to communicate control signals to a local system for controlling energy consumption thereof in response to user inputs received via the user input device and to input signals received via the wireless communication circuit.
2. The controller of claim 1, further comprising a thermostat with a temperature sensor, wherein the user input device is configured and arranged to receive thermostat inputs and wherein the control circuit is configured and arranged to control the local system as a function of the thermostat inputs, the temperature sensor and the input signals.
3. The controller of claim 2, further comprising a base including the wireless communication circuit and an antenna for communicating with the gateway, wherein the thermostat includes the user input device and the control circuit and is further configured and arranged to control the wireless communication circuit.
4. The controller of claim 3, wherein the base and thermostat are configured and arranged to replace a conventional thermostat arrangement for an HVAC system and to communicate the control signals to the HVAC system via electrical wires adapted to couple the conventional thermostat to an internal controller for the HVAC system.
5. The controller of claim 1, further configured and arranged to bind to a particular gateway and to respond to input signals from the particular gateway as a function of the binding.
6. The controller of claim 5, further configured and arranged to respond to input signals received only from the particular gateway.
7. The controller of claim 5, wherein the wireless communication circuit is configured and arranged to pass input signals received from the particular gateway to the control circuit as a function of the binding.
8. The controller of claim 5, wherein the control circuit is configured and arranged to respond to input signals received from the particular gateway as a function of the binding.
9. The controller of claim 5, wherein the wireless communication circuit has a unique identification and is configured and arranged to transmit the unique identification to the particular gateway to bind to the particular gateway.
10. The controller of claim 9, wherein the control circuit is configured and arranged to: receive a binding response from the gateway including the unique identification and a control identification, store the control identification and respond to input signals from the gateway that include the control identification.
11. The controller of claim 1, wherein the control circuit is configured and arranged to respond to utility input signals from the gateway indicating a high energy demand period by reducing energy consumption of the local system during the high energy demand period.
12. The controller of claim 1, wherein the control circuit is configured and arranged to control the local system as a function of utility inputs indicating utility pricing information received by the wireless communications circuit from the gateway.

**13.** The controller of claim 12, wherein the control circuit is configured and arranged to automatically set the local system's energy use as a function of utility rate tier information received from the gateway.

**14.** The controller of claim 1, wherein the control circuit is configured and arranged to display utility rate tier information received from the gateway for users at the controller and to control the local system in response to user input selections related to the rate tier information.

**15.** The controller of claim 1, wherein the control circuit and the wireless communication circuit are configured and arranged to send compliance information to the gateway indicative of a condition of compliance of the local system with the input signals.

**16.** The controller of claim 15, wherein the control circuit and the wireless communication circuit are configured and arranged to send acceptance information to the gateway indicative of a condition of a user's acceptance of an invitation to participate in an energy-saving event advertised via the input signals.

**17.** The controller of claim 16, wherein the user input device is configured and arranged to receive user inputs indicating the condition of the user's acceptance.

**18.** The controller of claim 15, wherein the control circuit is configured and arranged to compare the input signals to stored configuration information input via the user input device and to automatically participate in energy-saving events identified via the input signals as a function of the comparison.

**19.** The controller of claim 18, wherein the control circuit is configured and arranged to override the automatic participation in an energy-saving event in response to overriding inputs received via the user input device and to communicate the override condition to the gateway via the wireless communication circuit.

**20.** An HVAC control system comprising:

a wireless HVAC controller arrangement including a user input device, a wireless transceiver and a thermostat; and

a wireless gateway configured and arranged to wirelessly communicate control inputs to the HVAC controller via the wireless transceiver in response to remote control signals received from a remote source, the wireless HVAC controller arrangement being configured and arranged to control HVAC equipment as a function of the remote control signals and user inputs received via the user input device and to report characteristics of the operation of the HVAC equipment to the remote source via the wireless gateway.

**21.** The HVAC control system of claim 20, wherein the wireless HVAC controller arrangement is configured and arranged to receive user inputs for controlling the HVAC equipment and to override the user inputs as a function of the remote control signals received via the wireless gateway.

**22.** The HVAC control system of claim 20, wherein the wireless HVAC controller arrangement is configured and arranged to receive user inputs for overriding the remote control signals received via the gateway and to communicate the overriding condition to the remote source via the gateway.

**23.** The HVAC control system of claim 20, wherein the wireless HVAC controller arrangement comprises:

a base including the wireless transceiver and an antenna for wirelessly communicating with the gateway; and

a thermostat enclosure including the thermostat and the user input device and configured and arranged to physically and electrically couple to the base for communicating with and controlling the wireless transceiver.

**24.** The HVAC control system of claim 20, further comprising a plurality of wireless HVAC controller arrangements, each including a user input device, a wireless transceiver and a thermostat and each being configured and arranged to respond to remote control signals received from the wireless gateway.

**25.** The HVAC control system of claim 24, wherein the gateway is configured and arranged to individually bind to each of the plurality of wireless HVAC controller arrangements for selectively communicating therewith and wherein each of the HVAC controller arrangements is configured and arranged to process signals as a function of the individual binding.

**26.** The HVAC control system of claim 25, wherein the gateway is configured and arranged to assign an identifier to each of the plurality of wireless HVAC controller arrangements to bind thereto, the assigned identifiers being in a range of identifier values, and wherein the gateway identifies a wireless signal as a signal coming from one of the plurality of wireless HVAC controller arrangements by determining that an identifier associated with the wireless signal is in the range of identifier values.

**27.** The HVAC control system of claim 20, further comprising a plurality of wireless HVAC controller arrangements adapted to control environmental conditions in different zones supplied by the HVAC equipment, each including a user input device, a wireless transceiver and a thermostat and each being configured and arranged to respond to remote control signals received from the wireless gateway.

**28.** The HVAC control system of claim 20, further comprising a second wireless HVAC controller arrangement adapted to control additional HVAC equipment in response to user inputs and remote control signals, said wireless transceiver being configured and arranged to relay remote control signals received from the remote source to the second wireless HVAC controller arrangement and to relay operational characteristics of the additional HVAC equipment from the second wireless HVAC controller arrangement to the remote source via the gateway.

**29.** The HVAC control system of claim 20, wherein the wireless gateway is configured and arranged to receive remote control inputs from a user via the remote source, the remote control inputs including user inputs for the HVAC equipment, the HVAC controller arrangement being configured and arranged to control the HVAC equipment as a function of user inputs received with the remote control inputs and overriding user inputs received via the user input device.

**30.** The HVAC control system of claim 20, wherein the wireless gateway is configured and arranged to receive remote control inputs from a utility company via the remote source, the remote control inputs including utility control inputs for the HVAC equipment, the HVAC controller arrangement being configured and arranged to control the HVAC equipment as a function of the utility control inputs.

**31.** For use with a gateway communicatively coupled to a remote signal source, a local system controller comprising:



means for receiving user input;

wireless means for receiving input signals sent from the gateway in response to the remote signal source and for sending signals including information about the local system to the gateway; and

control means, coupled to the user input device and the wireless communication circuit, for communicating control signals to a local system for controlling energy consumption thereof in response to user inputs received via the user input device and to input signals received via the wireless communication circuit.

**32.** An HVAC controller comprising:

a thermostat;

a temperature sensor;

a user interface including an input device and a display;

a transceiver configured and arranged to wirelessly communicate with a utility company source for receiving utility control signals; and

a control circuit configured and arranged to control an HVAC system as a function of the utility control signals, the temperature sensor and user inputs received via the user interface, and further to communicate characteristics of the HVAC system operation to the utility company via the transceiver.

**33.** The HVAC controller of claim 32, wherein the control circuit and the transceiver are further configured and arranged to pass wireless communications signals as a gateway between the utility company source and at least one other HVAC controller for sending utility control signals to the at least one other HVAC controller for controlling another HVAC system and for reporting HVAC operational characteristics associated with the at least one other HVAC controller to the utility company source.

**34.** A method for controlling an HVAC system from a remote location, the method comprising:

sending a utility control signal to a local gateway;

in response to the utility control signal, sending a wireless signal from the local gateway to an HVAC controller coupled to control the HVAC system in response to user inputs and the utility control signal;

in response to the wireless signal, setting an operational characteristic of the HVAC system using the HVAC controller; and

reporting actual operational characteristics of the HVAC system with the HVAC controller by sending wireless signals to the remote location via the gateway.

**35.** The method of claim 34, further comprising:

using a communications identifier associated with signals sent by the gateway to the HVAC controller to identify the HVAC controller as the intended recipient of the signals.

**36.** The method of claim 35, further comprising:

polling the HVAC controller with the gateway;

in response to the polling, sending a unique identifier from the HVAC controller to the gateway, the unique identifier being unique to the HVAC controller;

sending the communications identifier to the HVAC controller using the unique identifier and storing the communications identifier at the HVAC controller; and

wherein using a communications identifier includes comparing the stored communications identifier with a communications identifier associated with signals from the gateway to identify the HVAC controller as the intended recipient of the signals.

**37.** A method for installing and operating a system for controlling HVAC equipment in response to utility control signals, the method comprising:

installing a wireless HVAC controller at a user-accessible location remote from the HVAC equipment, the wireless HVAC controller being adapted to receive control inputs for controlling the HVAC system and to control the HVAC system in response to the control inputs, the control inputs including local user inputs and remote utility control signals wirelessly received from a utility company; and

sending wireless utility control signals from the utility company to the wireless HVAC controller and controlling the HVAC system with the wireless utility control signals.

**38.** The method of claim 37, further comprising installing a gateway configured and arranged to send the wireless utility control signals to the wireless HVAC controller in response to signals sent from a utility company to the gateway.

**39.** The method of claim 38, further comprising communicatively binding the gateway to the wireless HVAC controller by establishing a unique communications identifier that indicates that a particular signal is intended for the wireless HVAC controller and including the unique communications identifier with the wireless utility control signals sent to the wireless HVAC controller.

\* \* \* \* \*