

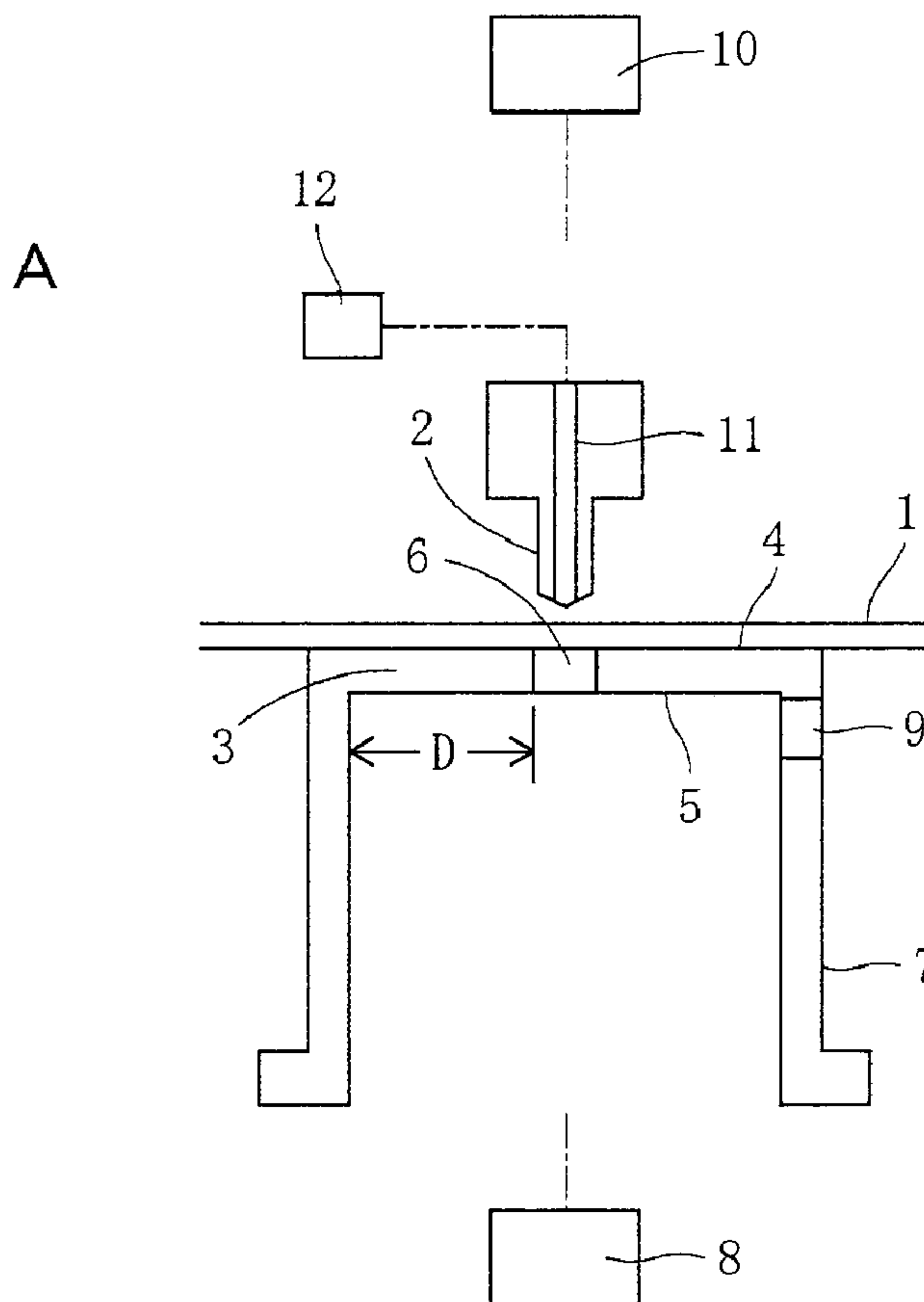

(22) **Date de dépôt/Filing Date:** 2016/01/05
 (41) **Mise à la disp. pub./Open to Public Insp.:** 2017/02/05
 (45) **Date de délivrance/Issue Date:** 2018/01/02
 (30) **Priorité/Priority:** 2015/08/05 (JP2015-155249)

(51) **Cl.Int./Int.Cl. B31B 50/14** (2017.01)
 (72) **Inventeur/Inventor:**
 OHNISHI, HIDEO, JP
 (73) **Propriétaire/Owner:**
 TOTANI CORPORATION, JP
 (74) **Agent:** FETHERSTONHAUGH & CO.

(54) **Titre : APPAREIL DE PERFORATION DE PELLICULE PLASTIQUE**
 (54) **Title: PLASTIC FILM PUNCHING APPARATUS**



(57) **Abrégé/Abstract:**

A plastic film punching apparatus is improved to make a waste 13 removed reliably. In the apparatus, a plastic film 1 is sandwiched between and punched by male and female blades 2 and 3. The female blade 3 has opposite surfaces which are first and second



(57) Abrégé(suite)/Abstract(continued):

surfaces 4 and 5. The plastic film 1 generates a waste 13 which is pushed by the male blade 2 to protrude from the second surface 5. A vacuum source 8 and an opening 9 cooperate with each other to suck air through the opening 9 and generate airflow 14 within the tubular cover 7, the waste 13 being removed by the airflow 14.

Abstract

A plastic film punching apparatus is improved to make a waste 13 removed reliably. In the apparatus, a plastic film 1 is sandwiched between and punched by male and female blades 2 and 3. The female blade 3 has opposite surfaces which are first and second surfaces 4 and 5. The plastic film 1 generates a waste 13 which is pushed by the male blade 2 to protrude from the second surface 5. A vacuum source 8 and an opening 9 cooperate with each other to suck air through the opening 9 and generate airflow 14 within the tubular cover 7, the waste 13 being removed by the airflow 14.

Plastic Film Punching Apparatus

Technical Field

The invention relates to a plastic film punching apparatus.

Background

For example, a plastic film punching apparatus is incorporated into a machine successively making plastic bags of plastic film, in which an aperture is formed in a plastic film.

Japanese Laid-Open Utility Model Publication No. H06-5,898 discloses the apparatus including a female blade, a through hole being formed in the female blade. A male blade is moved toward the female blade to be inserted into the through hole so that a plastic film is sandwiched between and punched by the male and female blades, the aperture being formed in the plastic film.

In this case, the plastic film generates a waste when being punched, the male blade and the waste being inserted into the through hole, so that the waste must be adhered to the male blade. In this connection, in the apparatus, an air passage is formed in the male blade to eject air to the waste from the air passage, the waste being removed by the ejected air.

However, the waste is not always peeled off the male blade and removed by the ejected air when ejecting the air to the waste. Accordingly, the waste may be then withdrawn by the male blade pulled out of the through hole, to be mixed into the plastic film.

The through hole is thought to be a cause. The waste must be held in the through hole to be restricted from movement when ejecting the air to the waste. The waste would therefore be difficult to be peeled off the male blade.

By the way, Japanese Patent No. 3,655,627 discloses a machine for successively making plastic bags of plastic film, in which plastic films are fed longitudinally thereof and intermittently. The machine includes a heat seal

apparatus and a cutter by which the plastic films are heat sealed with each other and cross cut when the plastic films are stopped temporarily whenever being fed intermittently, to successively make the plastic bags. The same is true of the plastic film punching apparatus incorporated into the machine. The plastic film is punched by the apparatus when the plastic film is stopped temporarily whenever being fed intermittently.

It is therefore an object of the invention to provide a plastic film punching apparatus in which the waste is removed reliably.

Summary of the Invention

According to the invention, the apparatus includes a female blade having opposite surfaces which are first and second surfaces. A male blade is opposed to the female blade at the first surface. A through hole is formed in the female blade for insertion of the male blade. A tubular cover is formed on the female blade at the second surface and about the through hole, the tubular cover being larger than the through hole. A vacuum source is connected to the tubular cover to make the tubular cover evacuated. An opening is formed in the tubular cover for suction of air at a position predetermined peripherally of the tubular cover. The apparatus further includes a drive by which the male blade is moved toward the female blade to be inserted into the through hole so that a plastic film is sandwiched between and punched by the male and female blades. The plastic film generates a waste which is inserted into the through hole. The waste is pushed by the male blade to protrude from the second surface. The vacuum source and the opening cooperate with each other to suck air through the opening and generate airflow within the tubular cover, the waste being removed by the airflow.

In a preferred embodiment, the male blade has a width, the opening having a width corresponding to or larger than the width of the male blade.

The male blade goes through the female blade to protrude from the

second surface. The waste protrudes from the second surface along with the male blade.

The opening is formed adjacent the second surface to generate the airflow adjacent the second surface.

The male blade is pronged to have two edges, the edges being spaced from each other in a direction of width of the male blade. The vacuum source and the opening generate the airflow in a direction of thickness of the male blade so that the air flows between the edges and between the male blade and the waste, resulting in the waste being peeled off the male blade reliably.

The vacuum source comprises a dust collector for collecting the wastes.

In addition, an air passage is formed in the male blade. An air supply is connected to the air passage to eject air to the waste from the air passage, assisting the airflow to make the waste removed.

According to an embodiment, there is provided a plastic film punching apparatus comprising: a female blade having opposite surfaces which are first and second surfaces; a male blade opposed to the female blade at the first surface; a through hole formed in the female blade for insertion of the male blade; a tubular cover formed on the female blade at the second surface and about the through hole, the tubular cover being larger than the through hole; a vacuum source connected to the tubular cover to make the tubular cover evacuated; an opening formed in the tubular cover for suction of air at a position predetermined peripherally of the tubular cover; and a drive by which the male blade is moved toward the female blade to be inserted into the through hole so that a plastic film is sandwiched between and punched by the male and female blades, the plastic film generating a waste which is inserted into the through hole, the waste being pushed by the male blade to protrude from the second surface, the vacuum source and the opening cooperating with each other to suck air through the opening and generate airflow within the tubular cover,

the waste being removed by the airflow, wherein the male blade is pronged to have two edges, the edges being spaced from each other in a direction of width of the male blade, the vacuum source and the opening generating the airflow in a direction of thickness of the male blade so that the air flows between the edges and between the male blade and the waste, resulting in the waste being peeled off the male blade reliably.

Brief Description of the Drawings

Fig. 1 is a longitudinal sectional view (A) of a preferred embodiment of the invention and a longitudinal sectional view (B) of the plastic film of (A) when being punched.

Fig. 2 is a cross sectional view (A) of the tubular cover of Fig. 1 and a cross sectional view (B) of another embodiment.

Fig. 3 is an elevational view (A) of the male blade of Fig. 1, a side view (B) of the male blade of (A) and a bottom view (C) of the male blade of (A).

Fig. 4 is an explanatory view (A) of the opening of Fig. 1 and an explanatory view (B) of another embodiment.

Fig. 5 is an elevational view (A) of another embodiment, a side view (B) of the male blade of (A) and a bottom view (C) of the male blade of (A).

Fig. 6 is a longitudinal sectional view (A) of another embodiment, a longitudinal sectional view (B) of another embodiment, a longitudinal sectional view (C) of another embodiment and a longitudinal sectional view (D) of another

embodiment.

Best Mode to Carry Out the Invention.

Turning now to the drawings, Fig. 1 illustrates a plastic film punching apparatus according to the invention. The apparatus is incorporated into a machine successively making plastic bags of plastic film, in which a plastic film 1 is punched by the apparatus. The apparatus includes male and female blades 2 and 3, the female blade 3 having opposite surfaces which are first and second surfaces 4 and 5. The male blade 2 is opposed to the female blade 3 at the first surface 4. A through hole 6 is formed in the female blade 3 for insertion of the male blade 2. A tubular cover 7 is formed on the female blade 3 at the second surface 5 and about the through hole 6, the tubular cover 7 being larger than the through hole 6. The tubular cover 7 is spaced from the through hole 6 at a distance D which is larger than the through hole 6.

In the embodiment, the female blade 3 has a disc shape while the tubular cover 7 is cylindrical. The tubular cover 7 extends vertically to have a top end which is closed by the female blade 3. The female blade 3 is formed integrally with the tubular cover 7. The through hole 6 is concentric with the tubular cover 7. The male blade 2 is disposed upwardly of the through hole 6. The tubular cover 7 may have an angled shape or another shape.

A vacuum source 8 is connected to the tubular cover 7 to make the tubular cover 7 evacuated. An opening 9 is formed in the tubular cover 7 for suction of air at a position predetermined peripherally of the tubular cover 7. In the embodiment, the vacuum source 8 comprises a dust collector while the opening 9 is formed adjacent the second surface 5.

The apparatus further includes a drive 10 by which the male blade 2 is moved toward the female blade 3 to be inserted into the through hole 6, the drive 10 comprising an actuator such as an air cylinder or motor. The drive 10 is connected to the male blade 2.

In addition, an air passage 11 is formed in the male blade 2. An air supply 12 is connected to the air passage 11, the air supply 12 comprising a compressor.

The apparatus is incorporated into the machine in which plastic films 1 are fed longitudinally thereof and intermittently, as in the case of the machine of Japanese Patent No. 3,655,627. The machine includes a heat seal apparatus and a cutter by which the plastic films 1 are heat sealed with each other and cross cut when the plastic films 1 are stopped temporarily whenever being fed intermittently, to successively make the plastic bags. In addition, one of the plastic films 1 is directed between the male and female blades 2 and 3. The male blade 2 is moved toward the female blade 3 to be inserted into the through hole 6 so that the plastic film 1 is sandwiched between and punched by the male and female blades 2 and 3 when the plastic film 1 is stopped temporarily whenever being fed intermittently.

The plastic film 1 generates a waste 13 when being punched, the male blade 2 and the waste 13 being inserted into the through hole 6. The waste 13 is pushed by the male blade 2 to protrude from the second surface 5. The vacuum source 8 and the opening 9 cooperate with each other to suck air through the opening 9 and generate airflow 14 within the tubular cover 7, the waste 13 being removed by the airflow 14.

The male blade 2 has a width (W1), as shown in Fig. 3, the opening 9 having a width (W2) corresponding to or larger than the width (W1) of the male blade 2, as shown in Fig. 4. The width (W2) is the size of the opening 9 in a direction of width of the male blade 2. In the embodiment, the male blade 2 is testudinal to have the width (W1) of 4 mm, the male blade 2 having a thickness (T) of 2 mm. The through hole 6 is also testudinal to have a size corresponding to that of the male blade 2. The opening 9 is circular to have the width (W2) which is a diameter (Fig. 4A). The opening 9 may be ellipse to have the width

(W2) which is a length of long axis (Fig. 4B).

The male blade 2 goes through the female blade 3 to protrude from the second surface 5. The waste 13 protrudes from the second surface 5 along with the male blade 2. The waste 13 can therefore protrude reliably.

In addition, in the apparatus, the male blade 2 is pronged to have two edges 15, the edges 15 being spaced from each other in the direction of width of the male blade 2. The vacuum source 8 and the opening 9 generate the airflow 14 in a direction of thickness of the male blade 2 so that the air flows between the edges 15 and between the male blade 2 and the waste 13, resulting in the waste 13 being peeled off the male blade 2 reliably.

The vacuum source 8 comprises the dust collector, as described previously, for collecting the wastes 13. The waste 13 can therefore be peeled off the male blade 2 to be removed by the airflow 14 and directed into the dust collector for collection.

It should therefore be understood that in the apparatus, the male blade 2 and the waste 13 are inserted into the through hole 6 so that the waste 13 protrudes from the second surface 5. The waste 13 is then removed by the airflow 14 not in the through hole 6 but within the tubular cover 7, without being held in the through hole 6 to be restricted from movement. The tubular cover 7 is larger than the through hole 6 which has a size corresponding to that of the waste 13. Accordingly, it is inconceivable that the waste 13 is held in the tubular cover 7 to be restricted from movement. The waste 13 is therefore peeled off the male blade 2 to be removed by the airflow 14 reliably.

The opening 9 is formed adjacent the second surface 5, as described previously, to generate the airflow 14 adjacent the second surface 5. The waste 13 is therefore more likely to be peeled off the male blade 2.

In the embodiment, the opening 9 is formed in the tubular cover 7 radially thereof, as shown in Fig. 2 (Fig. 2A). The opening 9 may be formed in the

tubular cover 7 tangentially thereof (Fig. 2B).

The apparatus is incorporated into the machine successively making plastic bags of plastic film, as described previously. In this connection, it should be understood that the machine has a problem that the waste 13 may be withdrawn by the male blade 2 pulled out of the through hole 6, to be mixed into the plastic film 1, if being not peeped off the male blade 2 for removal. In particular, the problem must be serious when the plastic bag is filled with food after making it.

Under the circumstances, the inventor has studied and tested about the relationship between the waste 13 to be removed and the size of the opening 9.

In this connection, it should be understood that in the apparatus of Fig. 1, the vacuum source 8 comprises the dust collector, the dust collector and the opening 9 cooperating with each other to suck the air through the opening 9. In this case, it is natural that the less the opening 9, the higher the speed of the air is obtained with the less the quantity of the air. By contraries, the larger the opening 9, the larger the quantity of the air is obtained with the lower the speed of the air. According to a test, the suction of the air has been accomplished through the opening 9 at a speed of 47.8 m/sec and a quantity of 9 l/min when the dust collector is operated to generate a negative pressure of 2.6 kPa and the opening 9 is circular to have a diameter of 2 mm. The suction of the air has been accomplished through the opening 9 at a speed of 41.1 m/sec and a quantity of 31 l/min when the opening 9 has a diameter of 4 mm. The suction of the air has been accomplished through the opening 9 at a speed of 27.1 m/sec and a quantity of 46 l/min when the opening 9 has a diameter of 6 mm.

It should also be understood that the speed and quantity of the air affect the waste 13 to be removed. In addition, in the test, the same male blade 2 has been used as the embodiment of Fig. 3, so that the air flows between the edges 15 and between the male blade 2 and the waste 13. The male blade 2 has the

width (W1) of 4 mm.

Furthermore, in the test, first, the inventor has tried to make the plastic film 1 punched by the male and female blades 2 and 3, 6,000 times, with no opening 9 formed in the tubular cover 7. In this case, the waste 13 would fall in the machine at a position downstream of the male blade 2 when being not peeled off the male blade 2 for removal. In fact, the waste 13 has fallen, nine times. The plastic film 1 has then been punched by the male blade 2, 6,000 times, with the opening 9 formed in the tubular cover 7, the opening 9 being circular to have a diameter of 2mm. In this case, the waste 13 has fallen, five times.

On the other hand, in the test, the waste 13 has fallen, one time, when the plastic film 1 is punched by the male blade 2, 6,000 times, with the opening 9 having a diameter of 4 mm. No waste 13 has fallen, when the plastic film 1 is punched by the male blade 2, 6,000 times, with the opening 9 having a diameter of 6 mm. No waste 13 has then fallen, when the plastic film 1 is punched again, 6,000 times, just to be sure.

Consequently, it has been known that the opening 9 is ineffective to make the waste 13 removed when having the diameter of 2 mm, due to the shortage of air in quantity, in spite of high speed. It has also been known that the opening 9 is effective to make the waste 13 removed when having the diameter of 4 mm, because of the waste 13 very rarely falling, and when having the diameter of 6 mm, because of no waste 13 falling. In the test, the male blade 2 has the width (W1) of 4mm, as described previously.

It should therefore be recognized that the test has indicated the importance of the width (W2) of the opening 9 relative to the width (W1) of the male blade 2. The width (W2) is the diameter of the opening 9 which is circular, as also described previously. The width (W2) may be the length of long axis of the opening 9 which is ellipse. As a result, a conclusion has been obtained that the waste 13 is removed reliably when the width (W2) corresponds to or larger

than the width (W1), in the apparatus of Fig. 1.

The male blade 2 and the through hole 6 may be circular, as shown in Fig. 5. In the embodiment of Fig. 5, the male blade 2 is pronged to have two edges 15 so that the air flows between the edges 15 and between the male blade 2 and the waste 13. The male blade 2 has a width (W1), the opening 9 having a width (W2) corresponding to or larger than the width (W1) of the male blade 2.

The male blade 2 may have a diamond shape or another shape.

In addition, the air supply 12 is connected to the air passage 11, as described previously, to eject air to the waste 13 from the air passage 11, assisting the airflow 14 to make the waste 13 removed.

The opening 9 may be inclined appropriately, as shown in Fig. 6 (Fig. 6A). The opening 9 may be enlarged in a direction in which the air flows (Fig. 6B). By contraries, the opening 9 may be contracted in the direction (Fig. 6C). In this case, the opening 9 should have a width (W2) corresponding to or larger than the width (W1) of the male blade 2 at the inner surface of the tubular cover 7. The opening 9 may have an orifice shape (Fig. 6D).

CLAIMS:

1. A plastic film punching apparatus comprising:
 - a female blade having opposite surfaces which are first and second surfaces;
 - a male blade opposed to the female blade at the first surface;
 - a through hole formed in the female blade for insertion of the male blade;
 - a tubular cover formed on the female blade at the second surface and about the through hole, the tubular cover being larger than the through hole;
 - a vacuum source connected to the tubular cover to make the tubular cover evacuated;
 - an opening formed in the tubular cover for suction of air at a position predetermined peripherally of the tubular cover; and
 - a drive by which the male blade is moved toward the female blade to be inserted into the through hole so that a plastic film is sandwiched between and punched by the male and female blades, the plastic film generating a waste which is inserted into the through hole, the waste being pushed by the male blade to protrude from the second surface, the vacuum source and the opening cooperating with each other to suck air through the opening and generate airflow within the tubular cover, the waste being removed by the airflow, wherein the male blade is pronged to have two edges, the edges being spaced from each other in a direction of width of the male blade, the vacuum source and the opening generating the airflow in a direction of thickness of the male blade so that the air flows between the edges and between the male blade and the waste, resulting in the waste being peeled off the male blade reliably.
2. The apparatus as set forth in claim 1 wherein the male blade has a width, the opening having a width corresponding to or larger than the width of the male blade.
3. The apparatus as set forth in claim 2 wherein the male blade goes through

the female blade to protrude from the second surface, the waste protruding from the second surface along with the male blade.

4. The apparatus as set forth in claim 2 wherein the opening is formed adjacent the second surface to generate the airflow adjacent the second surface.

5. The apparatus as set forth in claim 1 wherein the vacuum source comprises a dust collector for collecting the wastes.

6. The apparatus as set forth in claim 1 further comprising:
an air passage formed in the male blade; and
an air supply connected to the air passage to eject air to the waste from the air passage, assisting the airflow to make the waste removed.

Fig. 1

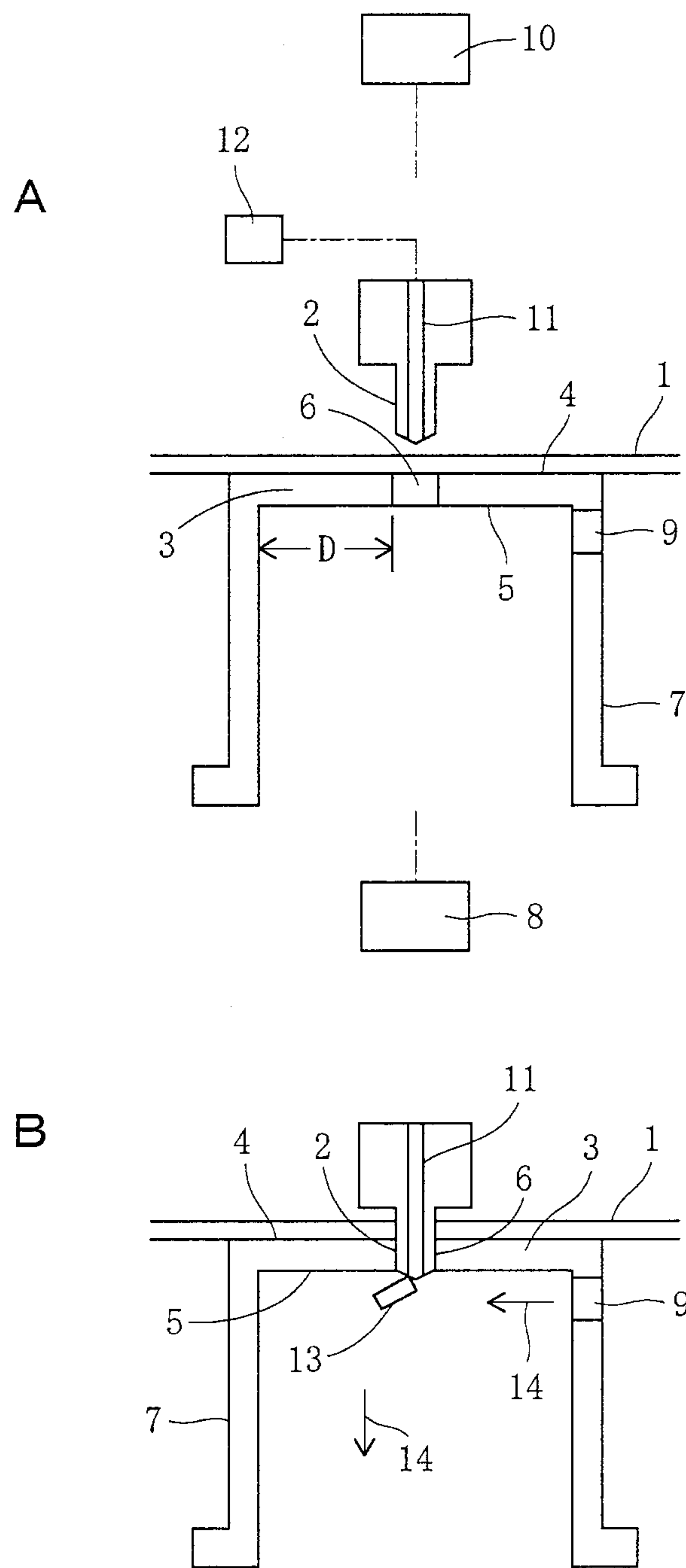

Fig. 2

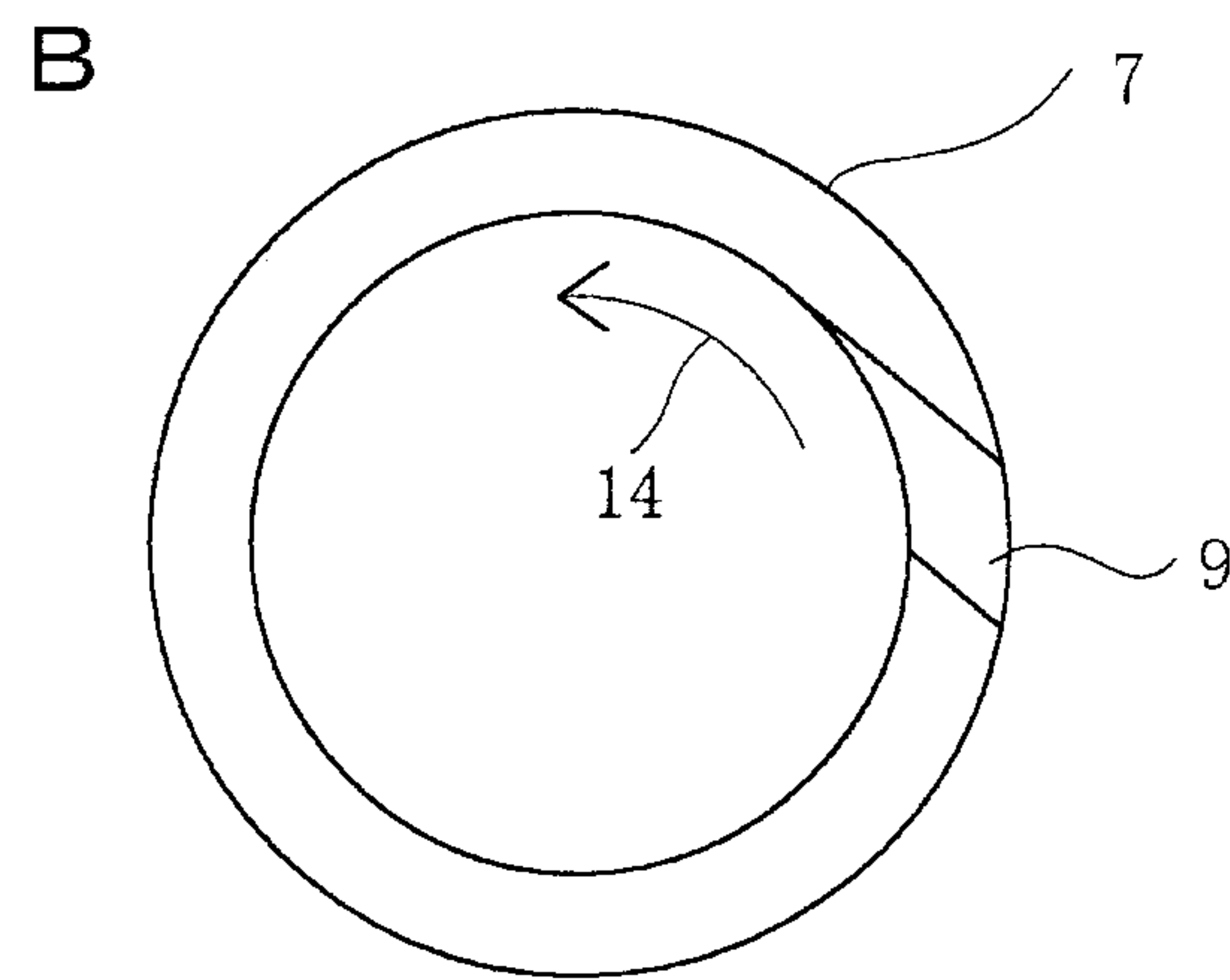
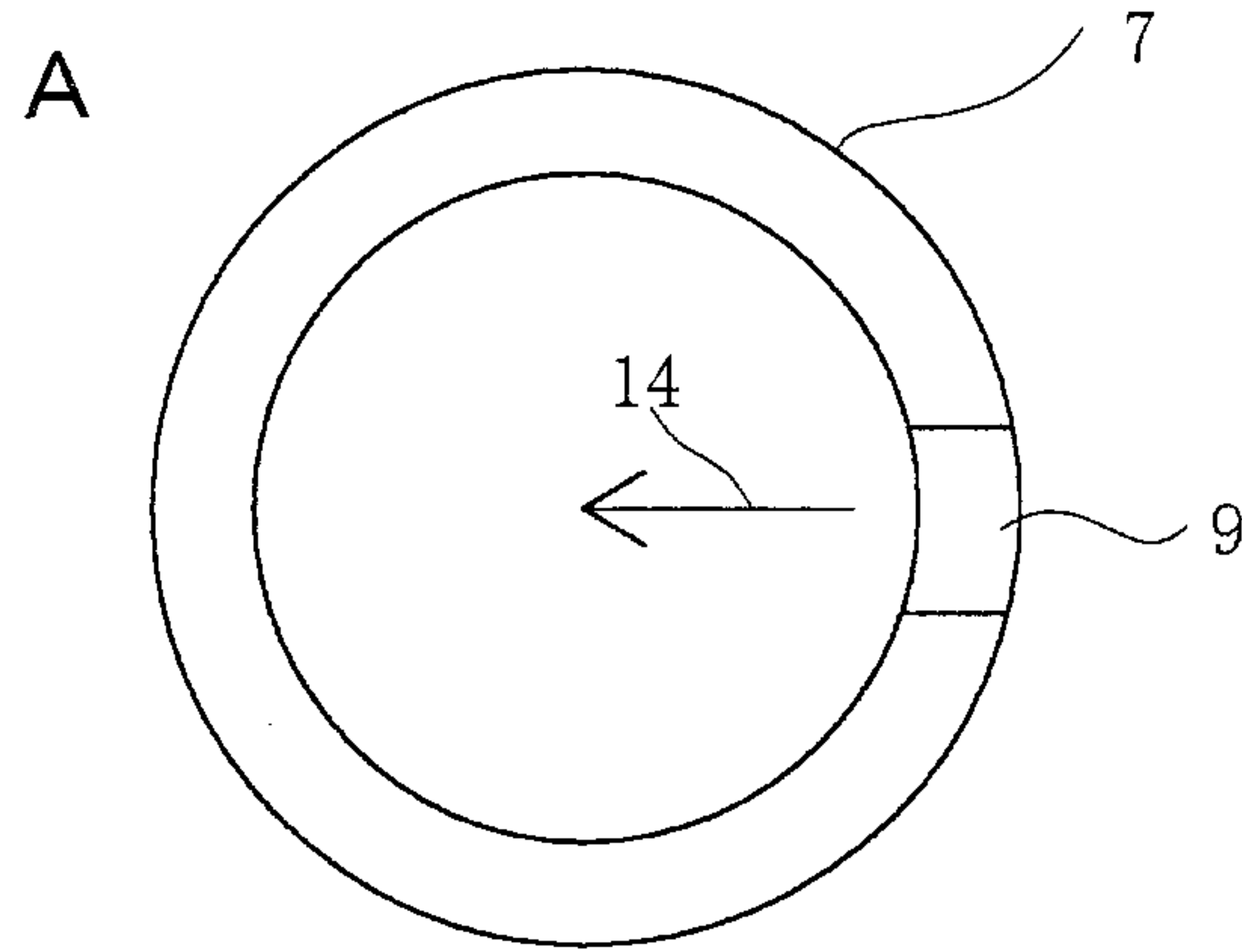

Fig. 3

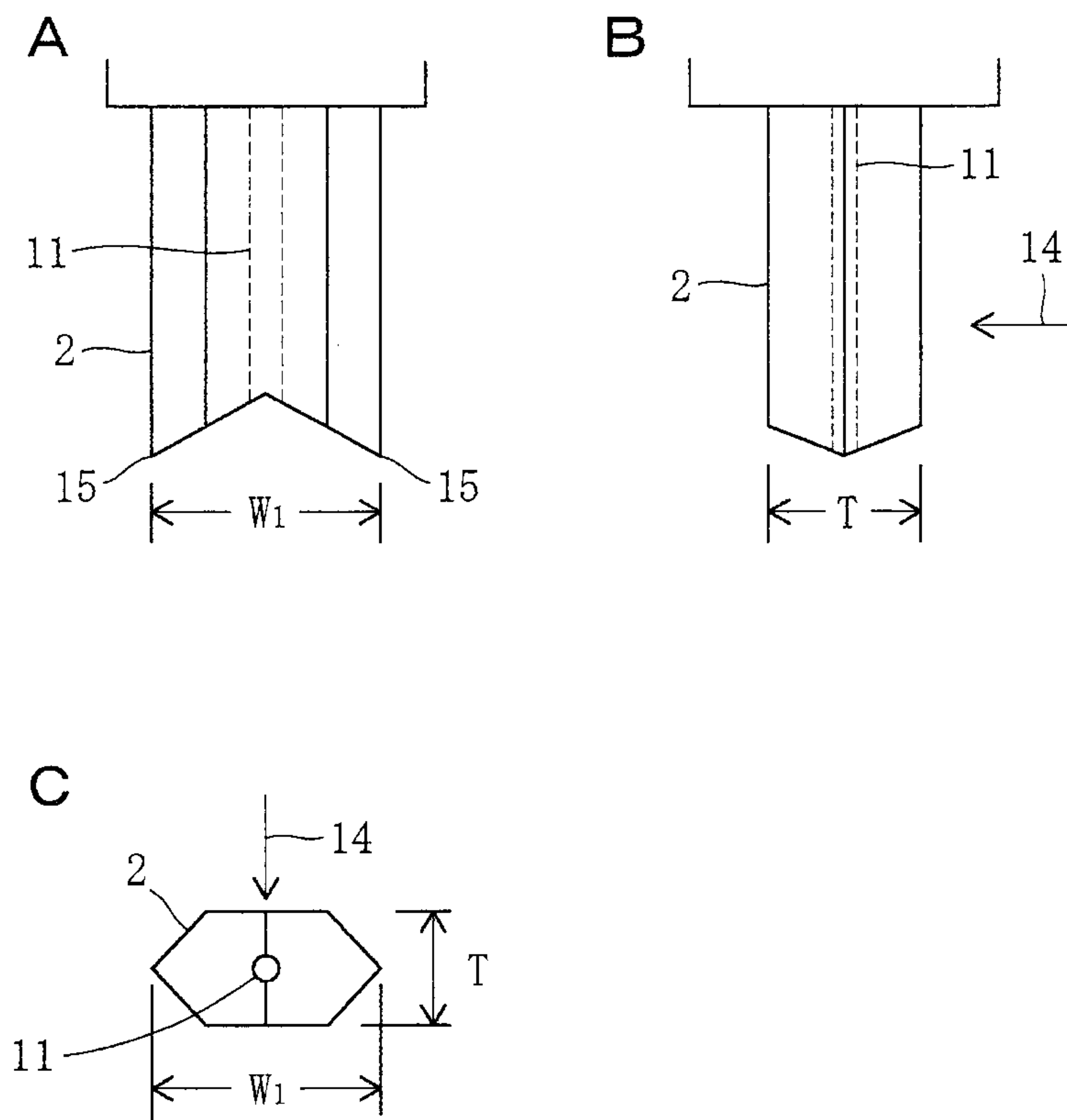

Fig. 4

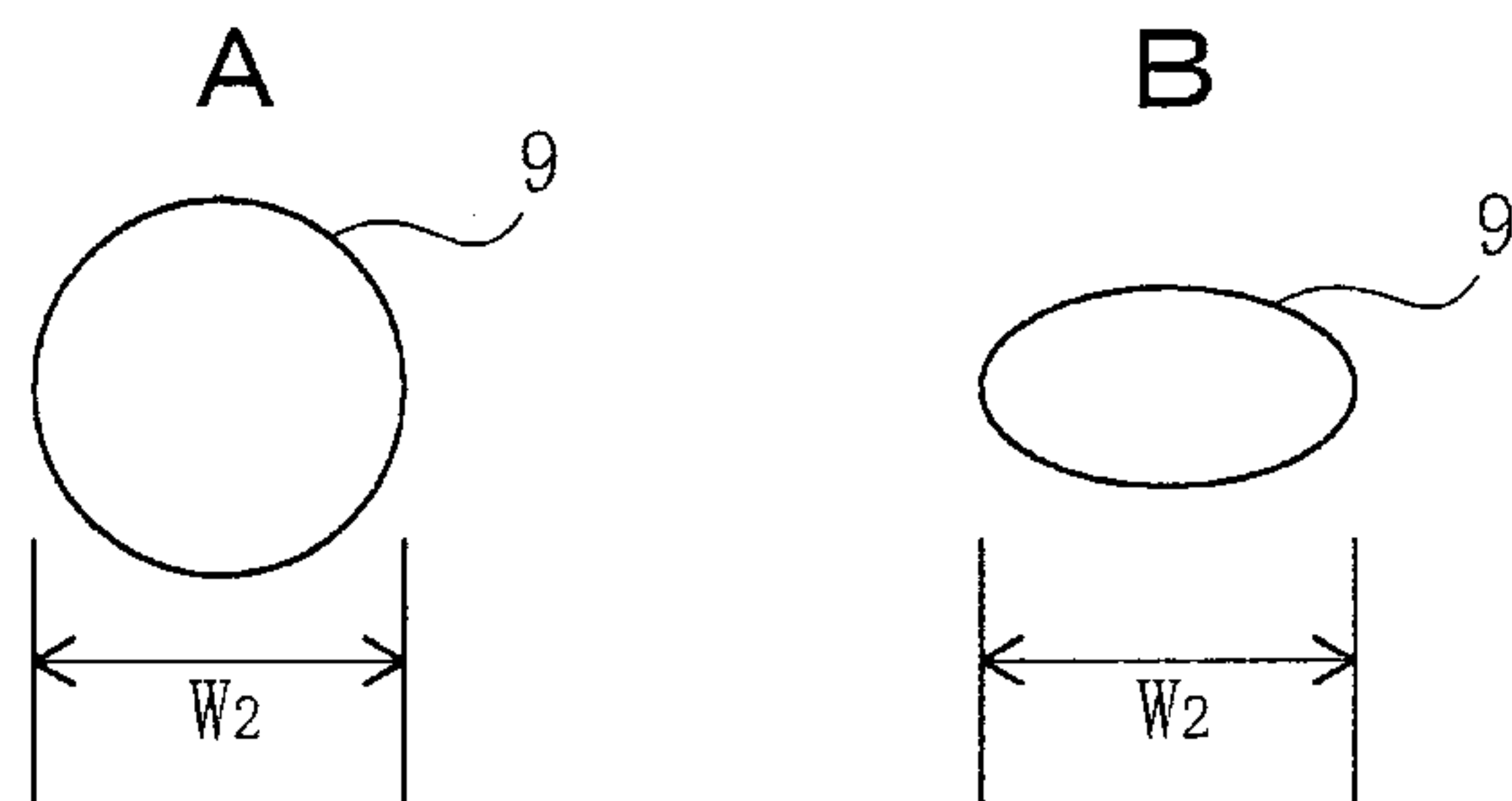

Fig. 5

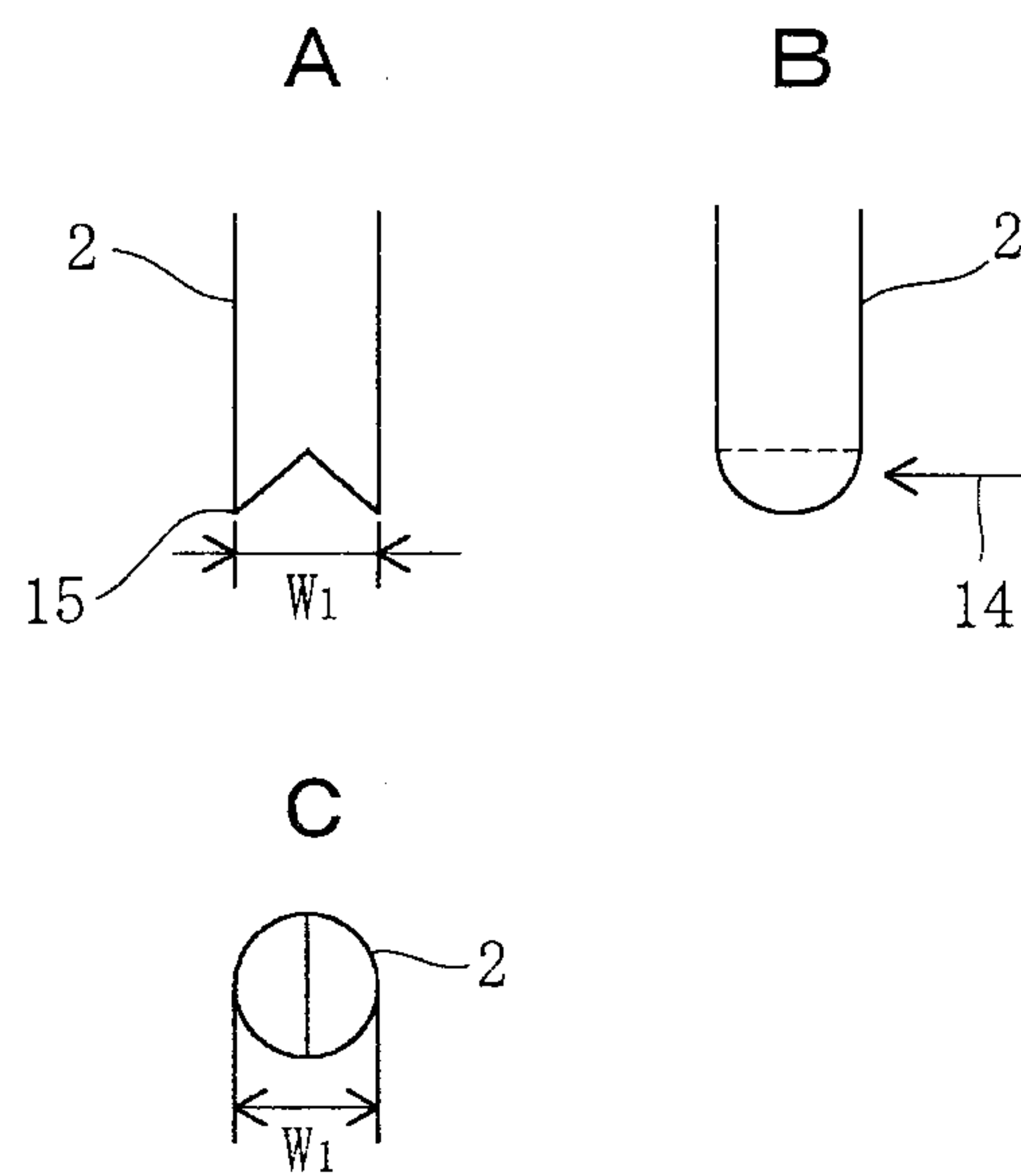
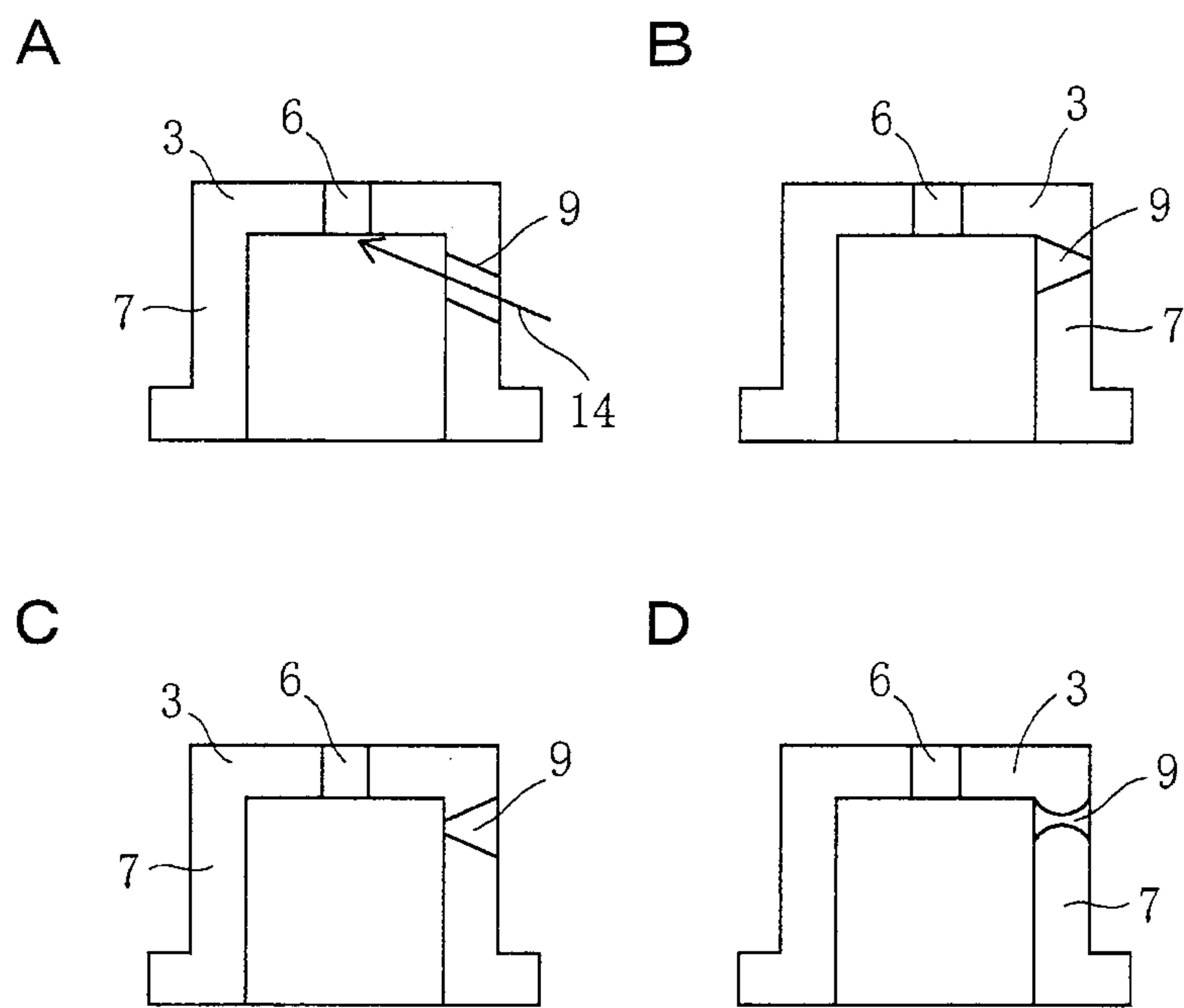

Fig. 6



A

