



(22) **Date de dépôt/Filing Date:** 2014/06/12

(41) **Mise à la disp. pub./Open to Public Insp.:** 2015/12/12

(51) **Cl.Int./Int.Cl.** E04G 1/00 (2006.01)

(71) **Demandeur/Applicant:**
HENNEJAK INC., CA

(72) **Inventeurs/Inventors:**
HENNEBERRY, DARREN, CA;
HENNEBERRY, GARY, CA

(74) **Agent:** KERR & NADEAU

(54) **Titre : SECTION D'ECHAFFAUDAGE**

(54) **Title: SCAFFOLDING SECTION**

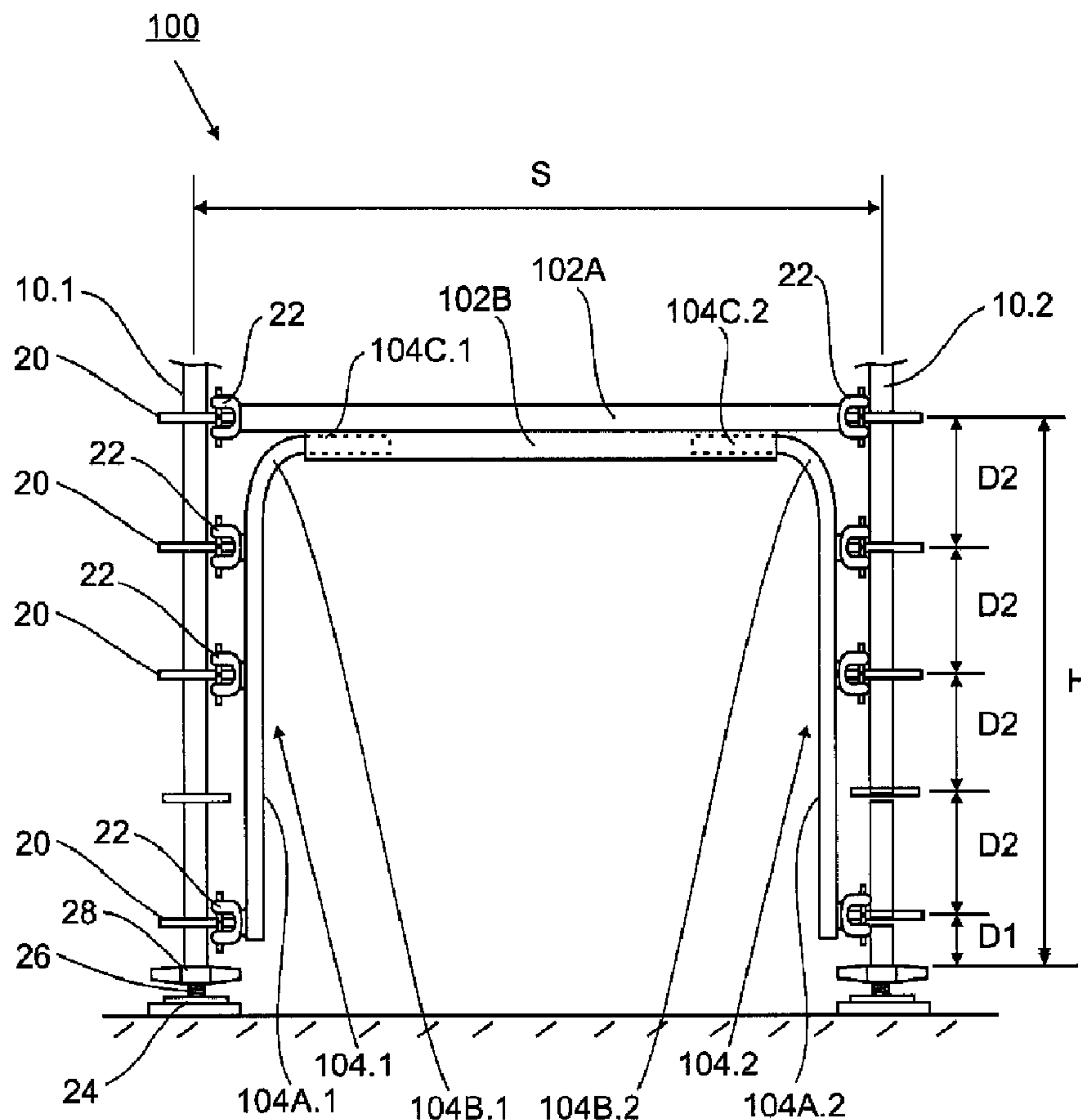

(57) **Abrégé/Abstract:**

A scaffolding section is provided. The scaffolding section comprises a first and a second standard. A substantially horizontally oriented ledger is connected to the first and the second standard a predetermined height above a bottom end of the first and the



(57) Abrégé(suite)/Abstract(continued):

second standard. An arch structure is disposed between the first and the second standard and below the ledger. The arch structure comprises at least a top part, a substantially straight first bottom part and a substantially straight second bottom part. The first and the second bottom part are disposed along a substantial length of the first and the second standard, respectively. The arch structure is mounted to the ledger, to the first standard, and to the second standard.

ABSTRACT

A scaffolding section is provided. The scaffolding section comprises a first and a second standard. A substantially horizontally oriented ledger is connected to the first and the second standard a predetermined height above a bottom end of the first and the second standard. An arch structure is disposed between the first and the second standard and below the ledger. The arch structure comprises at least a top part, a substantially straight first bottom part and a substantially straight second bottom part. The first and the second bottom part are disposed along a substantial length of the first and the second standard, respectively. The arch structure is mounted to the ledger, to the first standard, and to the second standard.

SCAFFOLDING SECTION

FIELD OF THE INVENTION

5 The present invention relates to scaffolding, and more particularly to a scaffolding section that provides a walking path therethrough.

BACKGROUND OF THE INVENTION

10 Typically, scaffolding is a temporary structure to support workers, materials and tools during construction and renovation of buildings. Main elements of present day scaffolding are: vertically oriented tubes – called standards; square base plates for supporting the standards and spreading the load; horizontally oriented tubes – called ledgers - connecting the standards at various levels; cross braces placed diagonally from ledger to ledger to increase rigidity; and, decks placed onto
15 the ledgers to provide a working surface.

The various elements of present day scaffolding are generally standardized, i.e. having standard dimensions as well as standard connectors for easily and removably connecting the standards, ledgers and cross braces. The base level of a standard scaffolding bay typically comprises: four
20 standards with each standard being supported by a base plate; four bottom ledgers connecting the four standards a distance of approximately 40cm above ground; four top ledgers connecting the four standards a distance of 2-3m above ground – called base lift; and, four cross braces with one cross brace placed between a respective pair of top and bottom ledgers.

25 Unfortunately, this type of standard scaffolding bay creates unsafe conditions for workers such as tripping hazards created by the bottom ledgers, as well as catch points for head, arm, shoulder, and elbow caused by the cross braces.

It is desirable to provide a scaffolding section that provides a walking path therethrough
30 substantially absent tripping hazards and catch points.

It is also desirable to provide a scaffolding section that provides a walking path therethrough and that is simple and cost effective.

5 It is also desirable to provide a scaffolding section that provides a walking path therethrough and that is implementable as a retrofit for use with existing scaffolding components.

SUMMARY OF THE INVENTION

10 Accordingly, one object of the present invention is to provide a scaffolding section that provides a walking path therethrough substantially absent tripping hazards and catch points.

Another object of the present invention is to provide a scaffolding section that provides a walking path therethrough and that is simple and cost effective.

15

Another object of the present invention is to provide a scaffolding section that provides a walking path therethrough and that is implementable as a retrofit for use with existing scaffolding components.

20 According to one aspect of the present invention, there is provided a scaffolding section. The scaffolding section comprises a first and a second standard. A substantially horizontally oriented ledger is connected to the first and the second standard a predetermined height above a bottom end of the first and the second standard. An arch structure is disposed between the first and the second standard and below the ledger. The arch structure comprises at least a top part, a
25 substantially straight first bottom part and a substantially straight second bottom part. The first and the second bottom part are disposed along a substantial length of the first and the second standard, respectively. The arch structure is mounted to the ledger, to the first standard, and to the second standard.

30 According to the aspect of the present invention, there is provided a scaffolding section. The scaffolding section comprises a first and a second standard. A substantially horizontally oriented

ledger is connected to the first and the second standard a predetermined height above a bottom end of the first and the second standard. An arch structure is disposed between the first and the second standard and below the ledger. The arch structure comprises a first arch section mounted to the first standard and the ledger and a second arch section mounted to the second standard and the ledger. Each arch section comprises a top part and a substantially straight bottom part. The bottom part of each arch section is disposed along a substantial length of the respective standard.

The advantage of the present invention is that it provides a scaffolding section that provides a walking path therethrough substantially absent tripping hazards and catch points.

A further advantage of the present invention is that it provides a scaffolding section that provides a walking path therethrough and that is simple and cost effective.

A further advantage of the present invention is to provide a scaffolding section that provides a walking path therethrough and that is implementable as a retrofit for use with existing scaffolding components.

BRIEF DESCRIPTION OF THE DRAWINGS

A preferred embodiment of the present invention is described below with reference to the accompanying drawings, in which:

Figure 1a is a simplified block diagram illustrating a front view of a scaffolding section according to a preferred embodiment of the invention;

Figure 1b is a simplified block diagrams illustrating in a perspective view a portion of a scaffolding with the scaffolding section according to a preferred embodiment of the invention;

Figure 1c is a simplified block diagram illustrating a perspective view of a standard coupler for connecting components of scaffolding to the standards;

Figures 2a and 2b are simplified block diagrams illustrating in a front view and a side view assembly of the scaffolding section according to a preferred embodiment of the invention;

5

Figures 3a to 3c are simplified block diagrams illustrating different implementations for connecting the arch structure to the ledger of the scaffolding section according to a preferred embodiment of the invention;

10

Figures 4a to 4d are simplified block diagrams illustrating different implementations of an arch section of the scaffolding section according to a preferred embodiment of the invention;

15

Figure 5 is a simplified block diagram illustrating a front view of a scaffolding section according to another embodiment of the invention; and,

Figure 6 is a simplified block diagram illustrating a front view of a scaffolding section according to yet another embodiment of the invention.

20

Figure 7 is a simplified block diagram illustrating a front view of a scaffolding section having a ladder attached thereto according to a preferred embodiment of the invention.

DESCRIPTION OF THE PREFERRED EMBODIMENT

25

Unless defined otherwise, all technical and scientific terms used herein have the same meaning as commonly understood by one of ordinary skill in the art to which the invention belongs.

Although any methods and materials similar or equivalent to those described herein can be used in the practice or testing of the present invention, the preferred methods and materials are now described.

30

While the description of the preferred embodiments hereinbelow is with reference to a standard

scaffolding bay, it will become evident to those skilled in the art that the embodiments of the invention are not limited thereto, but are also adaptable for use with non-standard scaffolding.

5 Referring to Figures 1a to 1c, a scaffolding section 100 according to a preferred embodiment of the invention is provided. As is evident to those skilled in the art, the scaffolding section 100 illustrated in Figure 1a can be combined with existing scaffolding components as illustrated in an exemplary implementation in Figure 1b, but is not limited thereto and may be implemented in different combinations and locations of scaffolding where it is desirable to provide a walking path. Furthermore, while only one level of the scaffolding is illustrated for simplicity, the scaffolding section 100 is also implementable in multi-level scaffolding and at different levels thereof.

15 In existing scaffolding, as illustrated in sections of the scaffolding illustrated in Figure 1b, a first standard 10 and a second standard 10 are connected to a respective first base plate 24 and second base plate 24 with a bottom portion of the tubing of the standards 10 accommodating therein a respective portion of threaded shank 26 mounted to a center of each base plate 24. A bottom end of each standard 10 is supported by wing nut 26 disposed on the threaded shank 24 for vertically adjusting the respective standard 10 in order to level the scaffolding. Typically, the standards 10 are connected to respective standards via substantially horizontally oriented bottom ledgers 14 – disposed a predetermined distance D1 of approximately 40cm above the bottom end of the standard 10 – and top ledgers 16 – disposed at base lift distance H of 2-3m above the bottom end of the standard 10. Cross braces 18 are placed between respective pairs of top ledgers 16 and bottom ledgers 14 to increase the rigidity of the scaffolding. Standard deck components (not shown) are supported by the top ledgers in a conventional fashion. Typically, the ledgers 14, 16 and cross braces 18 comprise standard couplers 22 which fit into one of rosettes 20 disposed along the standards 10 in equal distances D2 – typically 50cm - between two successive rosettes 20 and are fastened thereto in a standard fashion using wedge 22B placed in apertures 22A and 20A disposed in the coupler 22 and the rosette 20, respectively, as illustrated in Figure 1c.

30 The scaffolding section 100 provides walking paths - illustrated by the block arrows in Figure 1b - through the base level thereof substantially absent tripping hazards and catch points by

replacing the bottom ledgers 14 and the cross braces 18 crossing the walking paths with an arch structure disposed between two respective standards 10 and below ledger 102A.

Referring to Figure 1a, the arch structure of the scaffolding section 100 preferably comprises a first arch section 104.1 and a second arch section 104.2 with each arch section having: a substantially straight second bottom part 104A.1, 104A.2 disposed along a substantial length of the respective standard 10.1, 10.2; a top part 104B.1, 104B.2; and a top end portion 104C.1, 104C.2. Each arch section 104.1, 104.2 is removable mounted to the ledger 102A, preferably, by accommodating the top end portions 104C.1, 104C.2 in respective end portions of coupling tube 102B which is, for example, fastened to a bottom side of the ledger 102A. For example, the coupling tube 102A is adapted for enabling insertion/removal of the top end portions 104C.1, 104C.2 and rotation of the arch sections 104.1, 104.2 about a longitudinal axis of the coupling tube 102B while being inserted therein for facilitating assembly/disassembly of the arch structure, as will be described hereinbelow.

The first and the second bottom part 104A.1, 104A.2 are mounted to the respective standard 10.1, 10.2, preferably, at a plurality of locations along the respective standard 10.1, 10.2 with a first location placed in close proximity to a bottom end of the respective standard 10.1, 10.2 and a second location placed in a top part of the respective standard 10.1, 10.2. Preferably, standard couplers 22 are disposed at predetermined locations along the first and the second bottom part 104A.1, 104A.2 such that they coincide with respective rosettes 20 disposed along the standards 10.1, 10.2. For example, the couplers 22 are directly fastened to the first and the second bottom part 104A.1, 104A.2 enabling placement of the same in close proximity to the standards 10.1, 10.2, as illustrated in Figure 1a. Further preferably, more than two couplers are disposed along the first and the second bottom part 104A.1, 104A.2.

The coupling tube 102B and the arch sections 104.1, 104.2 are made of, for example, metal tubing such as steel or aluminum tubing in a conventional manner. The coupling tube 102B is fastened to the ledger 102A and the couplers are fastened to the arch sections 104.1, 104.2 using conventional fastening technologies such as welding.

The coupling tube 102B and the arch sections 104.1, 104.2 are, preferably, adapted such that the arch sections can be mounted to the coupling tube 102B and standards 10.1, 10.2 of an erected scaffolding section, as illustrated in Figures 2a and 2b for the arch section 104.2. First, the top end portion 104C.2 is inserted into the respective end portion of the coupling tube 102B as indicated by the block arrow in Figure 2a with the bottom portion 104A.2 being disposed at an acute angle α to the standard 10.2 as illustrated in Figure 2b. After insertion, the arch section 104.2 is rotated about the longitudinal axis 103 of the coupling tube 102B until the same is oriented substantially parallel to the standard 10.2, as indicated by the block arrow in Figure 2b. The arch section 104.2 is then moved along the axis 103 towards the standard 10.2 a short distance until the couplers 22 are interacting with the respective rosettes 20 for being coupled thereto. The same process is repeated for assembling the arch section 104.1, as well as for disassembling the arch sections with the steps being performed in reverse order.

In an alternative embodiment, illustrated in Figure 3a, the coupling tube 102B is replaced by two shorter coupling tubes 202B having sufficient length for accommodating the respective top end portions 104C.1, 104C.2 therein. In order to increase the bending resistance of the ledger 102A – for example, when the scaffolding section 100 has a wide span S between the standards 10.1, 10.2 – reinforcing structure 220 is disposed between the ledger 102A and the coupling tube 102B, as illustrated in Figure 3b, and fastened thereto in a conventional manner using, for example, welding. Further alternatively, the top end portions 104C.1, 104C.2 comprise end extensions 230 which are mounted to the ledger 102A via screw bolts 232 disposed in respective bores disposed in the extensions 230 and the ledger 102A, as illustrated in Figure 3c.

In order to reduce the number of different components, the same component is used to provide the arch section 104.1 as well as the arch section 104.2. Furthermore, the same arch sections are employed for implementing different spans S of the scaffolding section 100 with the different spans S being realized by using different ledgers/coupling tubes 102A/102B. Different heights H of the scaffolding section 100 are accommodated by using arch sections having different vertical length LV while horizontal length LH is kept the same, as illustrated in Figures 4a and 4b.

Alternatively, the arch section is divided in a top part 204B and a bottom part 204A with, for example, a top end portion 204A.1 of the bottom part 204A being accommodated in a respective

bottom end portion 204B.1 of the top part 204B, as illustrated in Figure 4c. Here, different heights H of the scaffolding section 100 are accommodated by using bottom parts 204A having different lengths coupled to the same top part 204B. Further alternatively, the different heights H of the scaffolding section 100 are accommodated by extending/retracting the bottom part 304A with respect to the top part 304B in a telescopic fashion, as illustrated in Figure 4d.

Referring to Figure 5, in an alternative embodiment a top of the arch structure 402B is fastened - in a conventional manner using for example, welding - to the ledger 402A and has couplers 22 fastened thereto for mounting the same to the standards 10.1 and 10.2. Bottom parts 404A.1 and 404A.2 are coupled to the arch structure 402B in a conventional manner as described hereinabove, and to the respective standard 10.1, 10.2.

Referring to Figure 6, in a further alternative embodiment arch sections 504.1, 504.2 each comprise a substantially straight top part 504B.1, 504B.2 - instead of the curved top part 104B.1, 104B.2 illustrated in Figure 1a - interposed between a substantially straight bottom part 504A.1, 504A.2 and substantially straight top end portion 504C.1, 504C.2 and angled thereto.

Referring to Figure 7, provision of the arch section 104.1 enables secure attachment of a ladder 602 to the scaffolding section 100 without obstructing a pathway through the scaffolding. Ladder support post 604 - having the ladder 602 securely mounted thereto via standard ladder brackets 610 - is securely mounted to the scaffolding section 100 via short scaffold tube 606 which is securely mounted to the standard 10.1 and the arch section 104.1 using, for example, standard right angle wedge clamps 608. For simplicity, only securing of the bottom portion of the ladder support post 604 is illustrated. As is evident to one skilled in the art, the ladder support post 604 may be secured to the scaffold at different levels in a similar fashion.

The present invention has been described herein with regard to preferred embodiments. However, it will be obvious to persons skilled in the art that a number of variations and modifications can be made without departing from the scope of the invention as described herein.

30

THE EMBODIMENTS OF THE INVENTION IN WHICH AN EXCLUSIVE PROPERTY OR PRIVILEGE IS CLAIMED ARE DEFINED AS FOLLOWS:

1. A scaffolding section comprising:
 - 5 a first and a second standard;
a substantially horizontally oriented ledger connected to the first and the second standard a predetermined height above a bottom end of the first and the second standard; and,
an arch structure disposed between the first and the second standard and below the ledger,
the arch structure comprising at least a top part, a substantially straight first bottom part and a
10 substantially straight second bottom part, the first and the second bottom part being disposed along a substantial length of the first and the second standard, respectively, the arch structure being mounted to the ledger, to the first standard, and to the second standard.
2. The scaffolding section according to claim 1 wherein the first and the second bottom part are
15 disposed in close proximity to the first and the second standard, respectively.
3. The scaffolding section according to claim 2 wherein the arch structure is mounted to each standard at a plurality of locations along the respective standard.
- 20 4. The scaffolding section according to claim 3 wherein the arch structure is mounted to each standard at a first location placed in close proximity to a bottom end of the respective standard and at a second location placed in a top part of the respective standard.
- 25 5. The scaffolding section according to claim 1 wherein the arch structure comprises a first arch section mounted to the first standard and the ledger and a second arch section mounted to the second standard and the ledger.
6. The scaffolding section according to claim 5 wherein the first arch section and the second arch section are removable mounted to the respective standard and the ledger.
- 30 7. The scaffolding section according to claim 6 wherein the first and the second bottom part are

disposed in close proximity to the first and the second standard, respectively.

8. The scaffolding section according to claim 7 wherein the first arch section and the second arch section are mounted to the respective standard at a plurality of locations along thereof.

5

9. The scaffolding section according to claim 8 wherein the first arch section and the second arch section are mounted to the respective standard at a first location placed in close proximity to a bottom end of the respective standard and at a second location placed in a top part of the respective standard.

10

10. The scaffolding section according to claim 9 wherein the first arch section and the second arch section are mounted to the respective standard at a location placed between the first location and the second location.

15

11. The scaffolding section according to claim 8 wherein the first arch section and the second arch section are mounted to the respective standard using standard couplers fastened to respective rosettes placed at predetermined locations along the standard.

20

12. The scaffolding section according to claim 8 comprising a coupling tube mounted to the ledger, the coupling tube being adapted for accommodating a top end portion of the first arch section and the second arch section therein.

13. The scaffolding section according to claim 12 wherein the first arch section and the second arch section are rotatable about a longitudinal axis of the coupling tube.

25

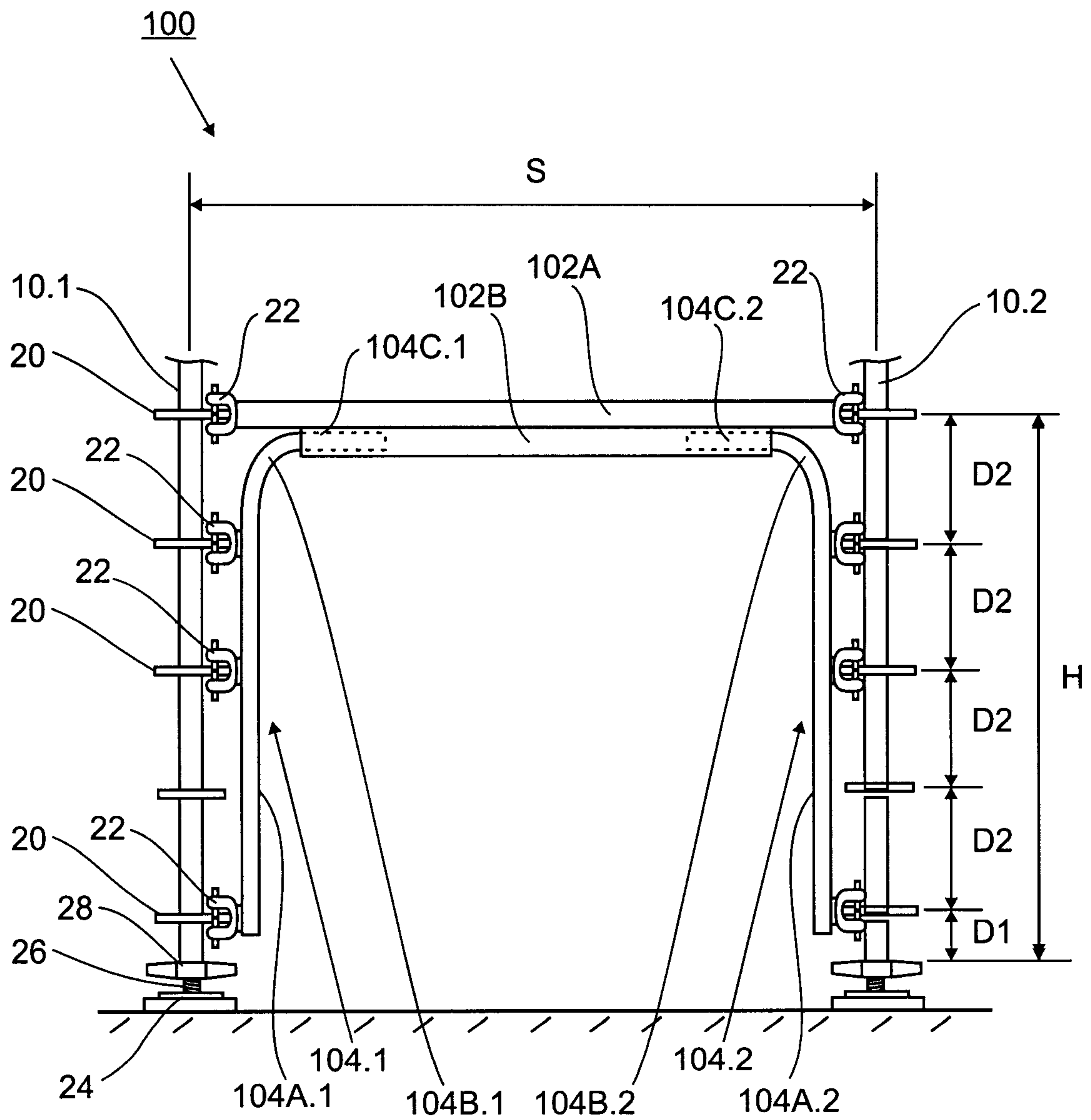

Figure. 1a

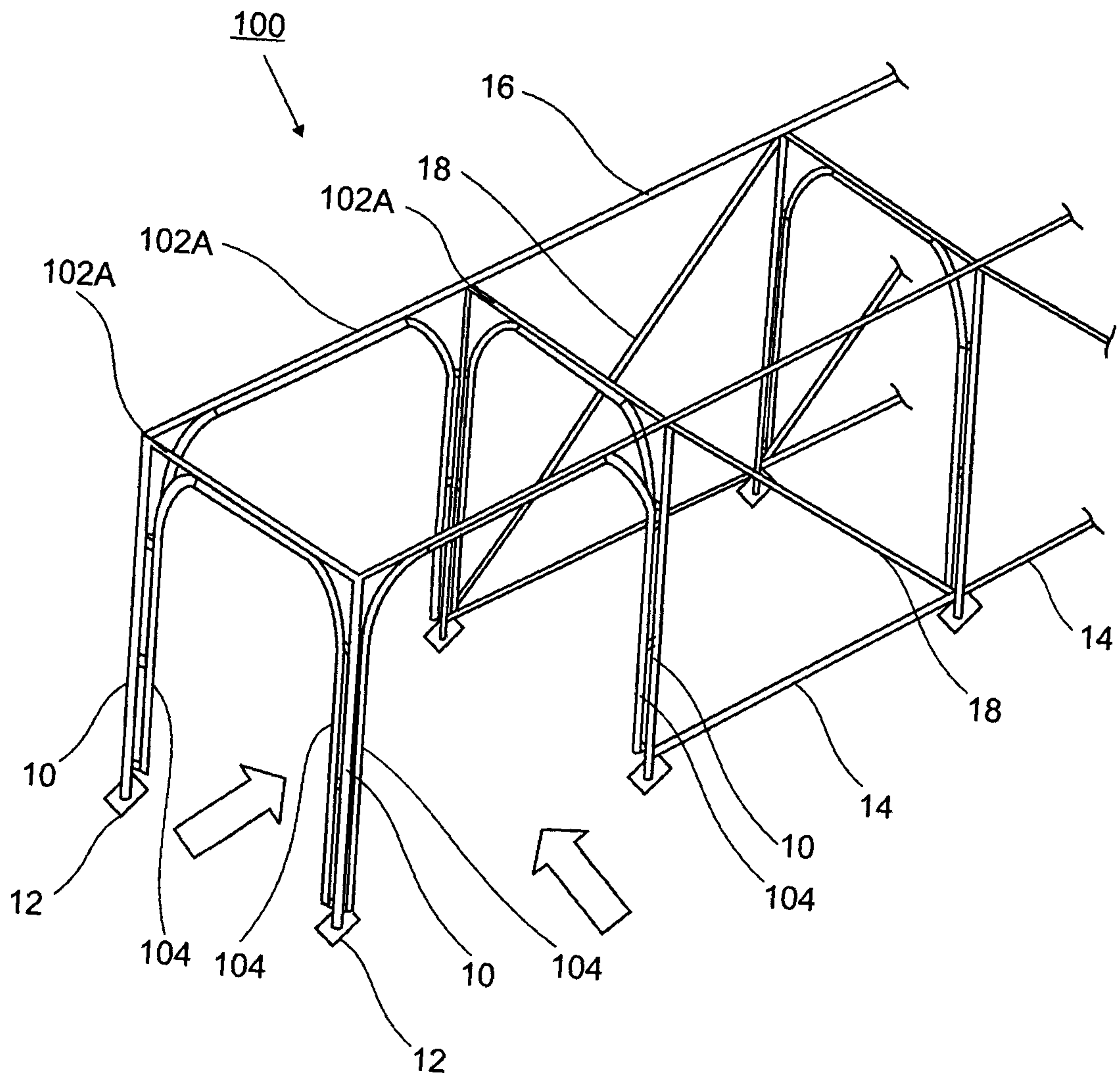

Figure. 1b

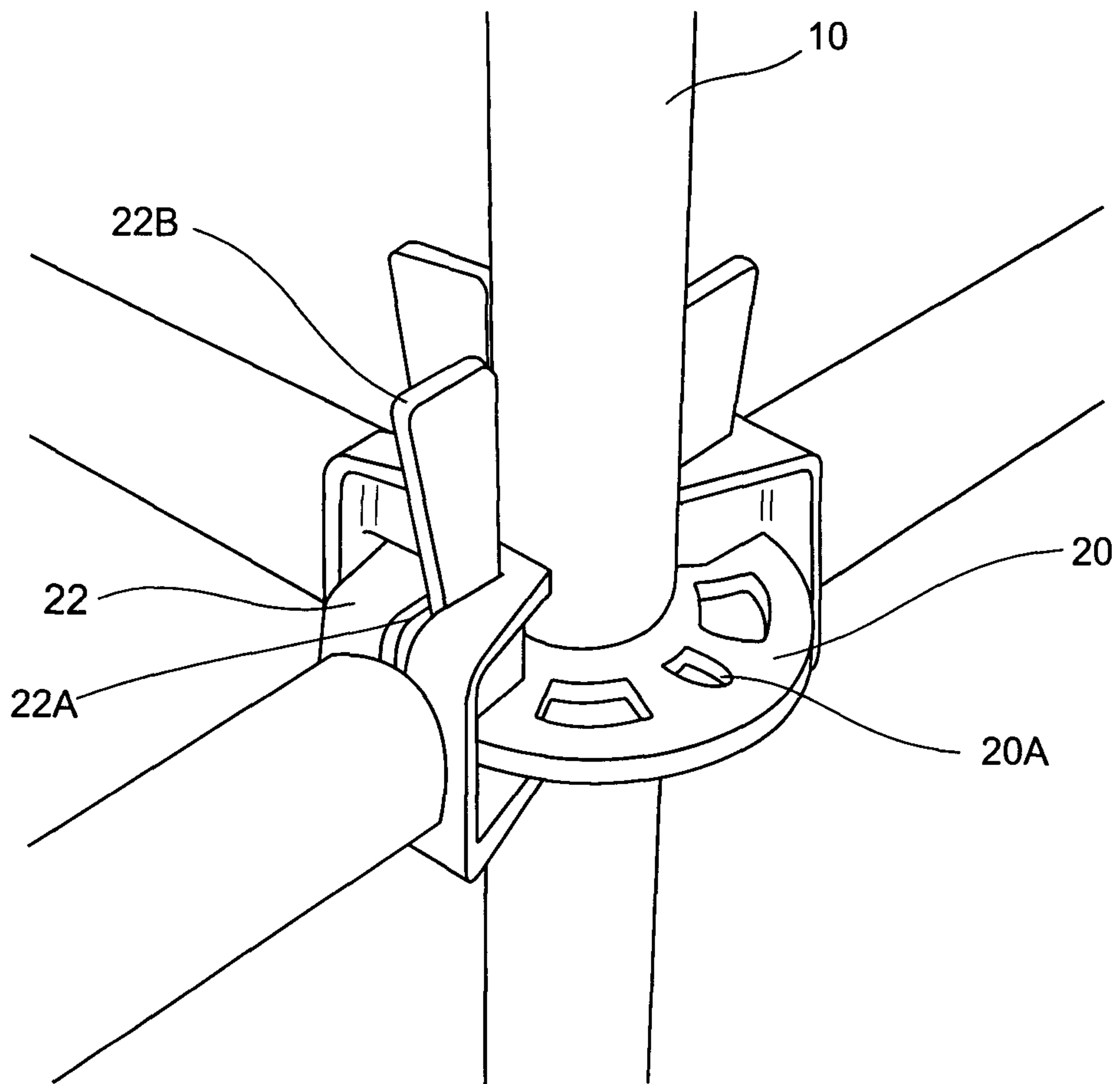

Figure. 1c
(Prior Art)

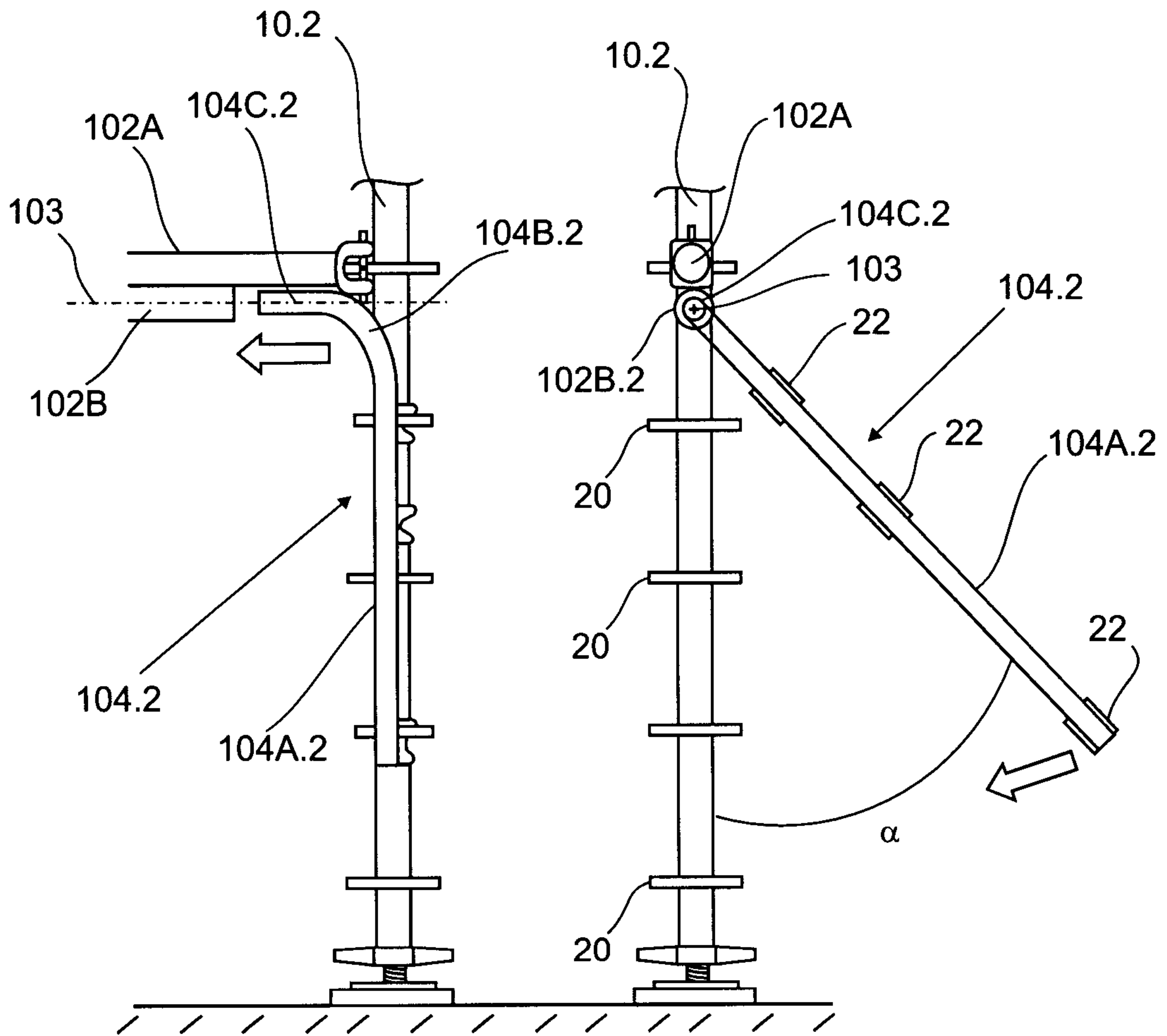

Figure. 2a

Figure. 2b

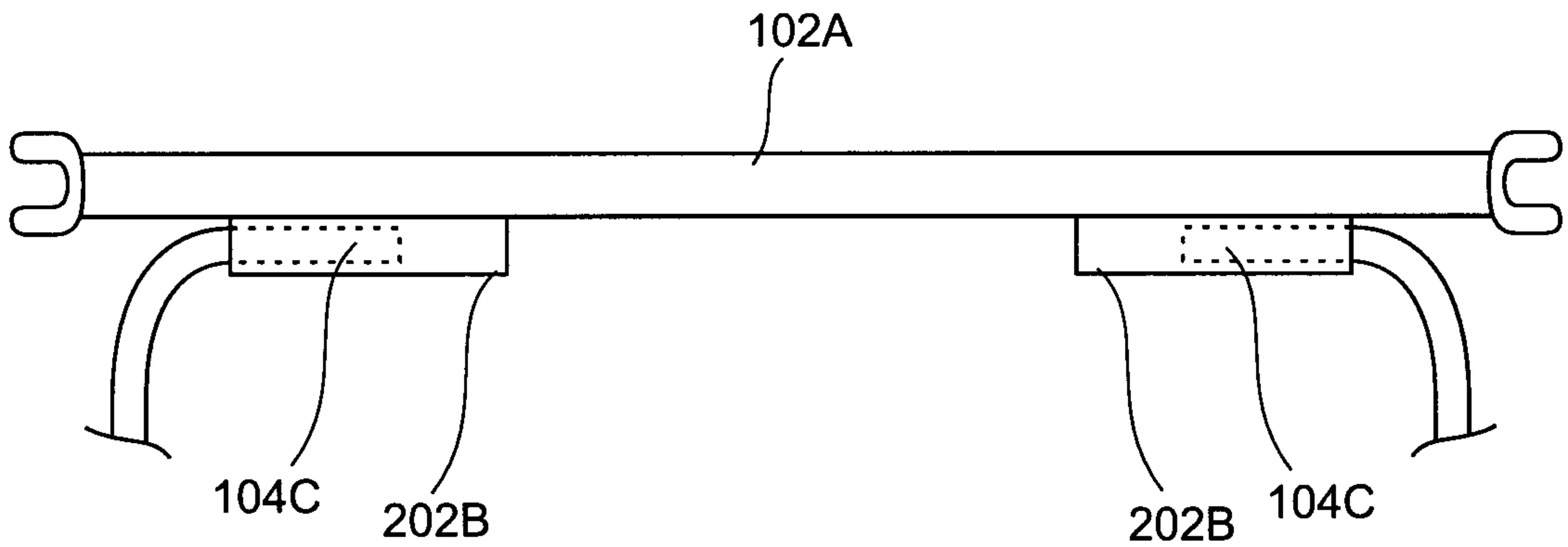

Figure. 3a

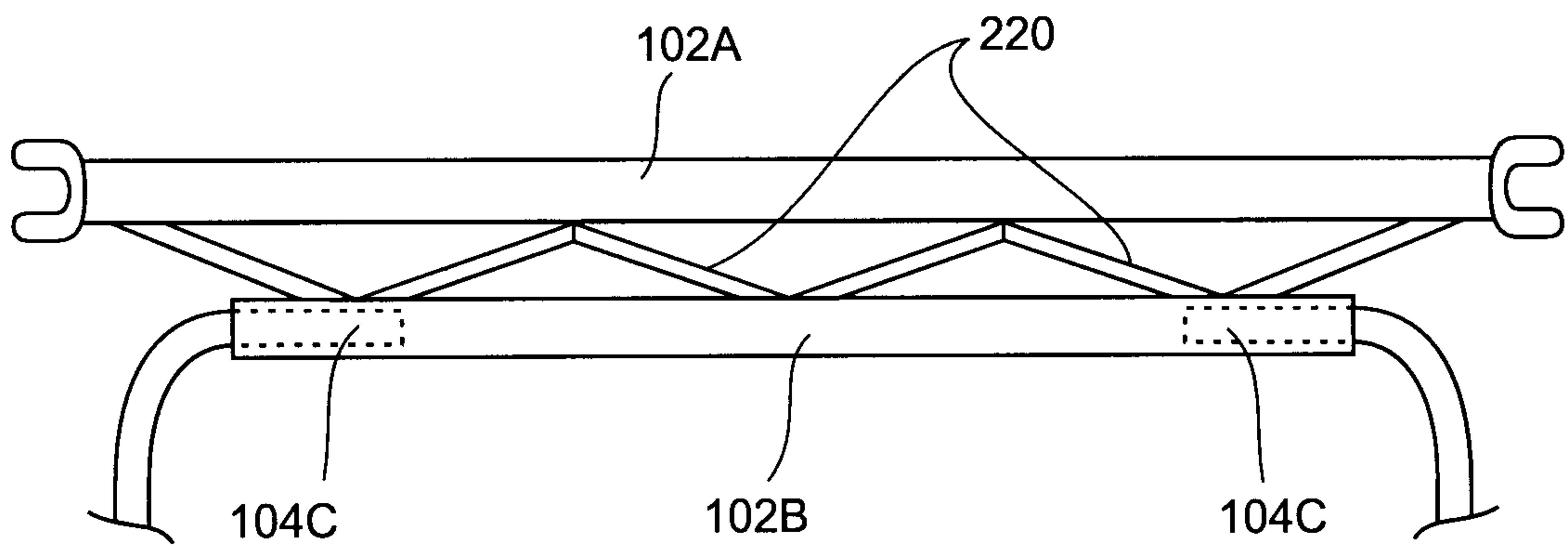

Figure. 3b

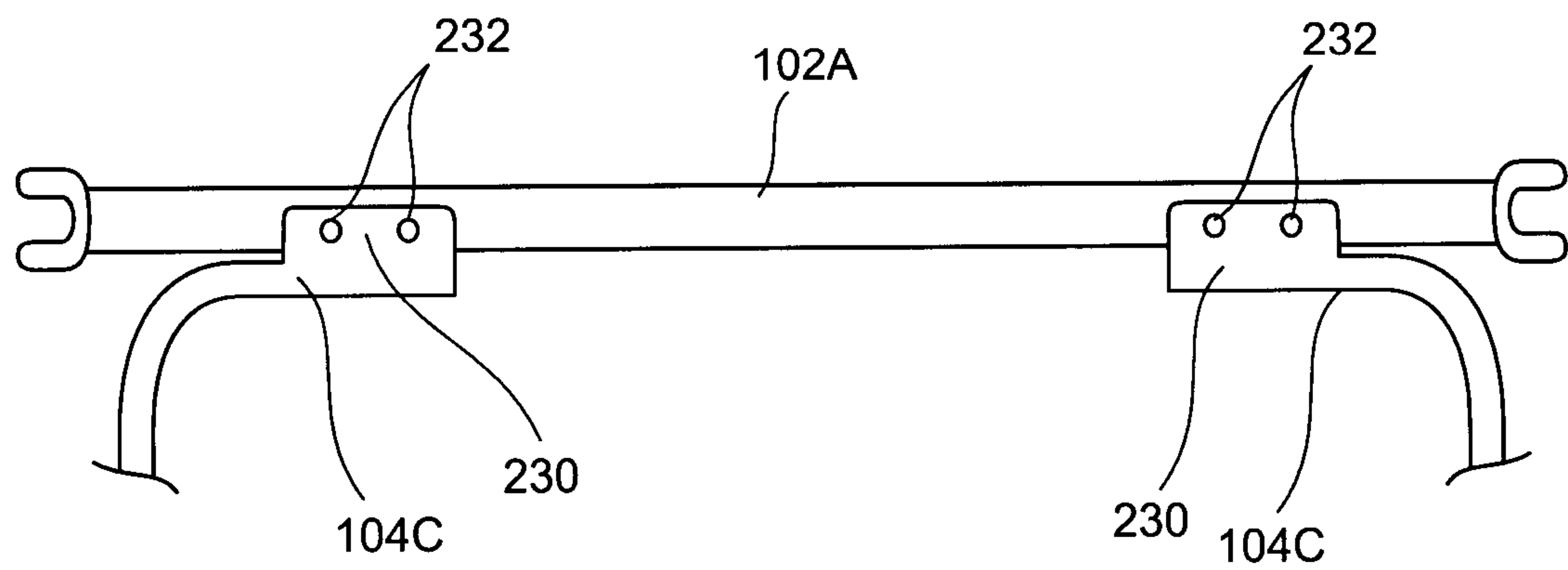

Figure. 3c

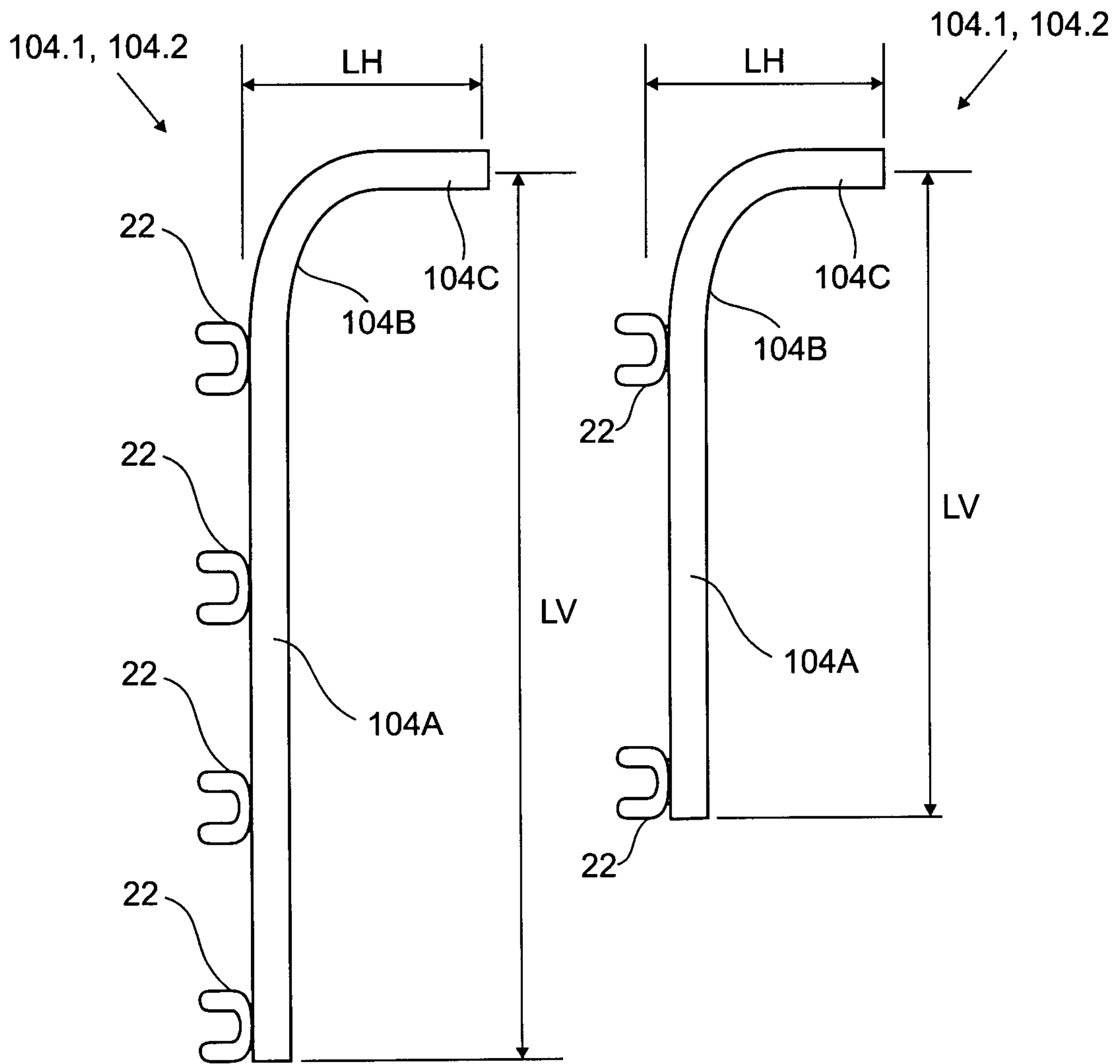

Figure. 4a

Figure. 4b

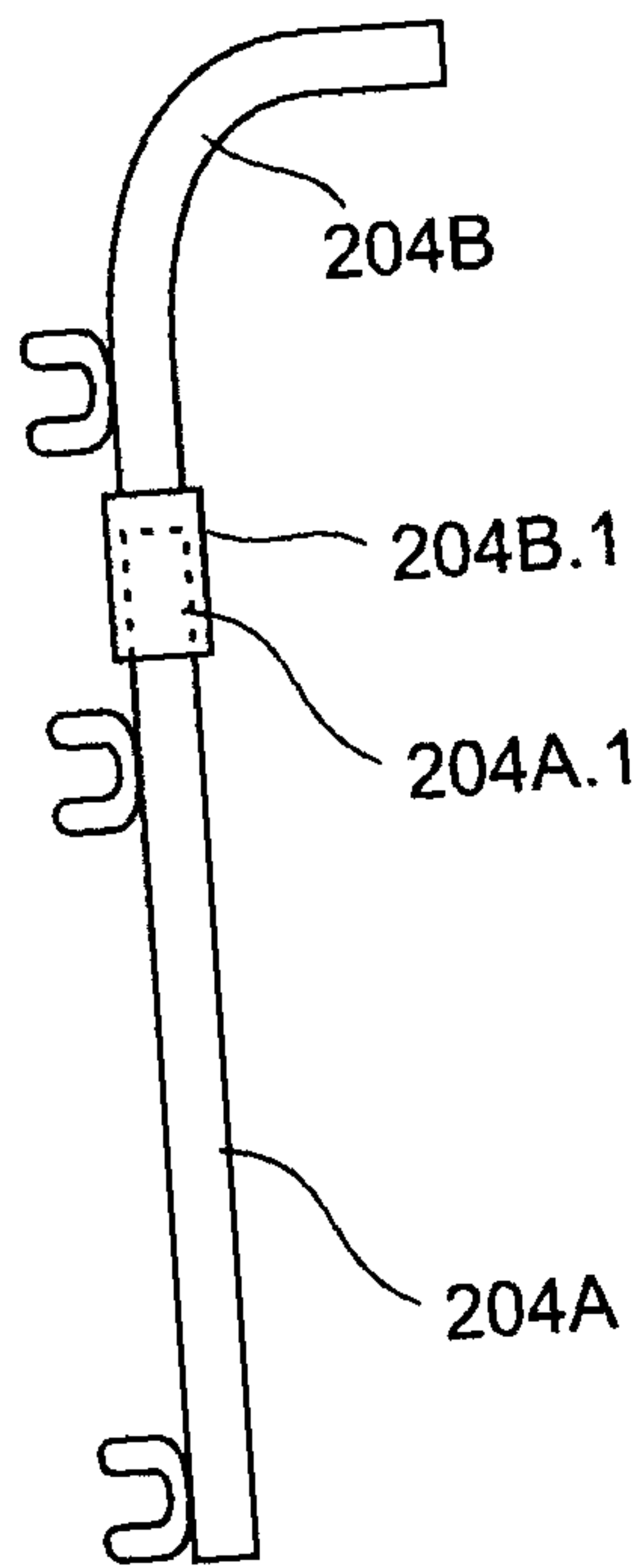

Figure. 4c

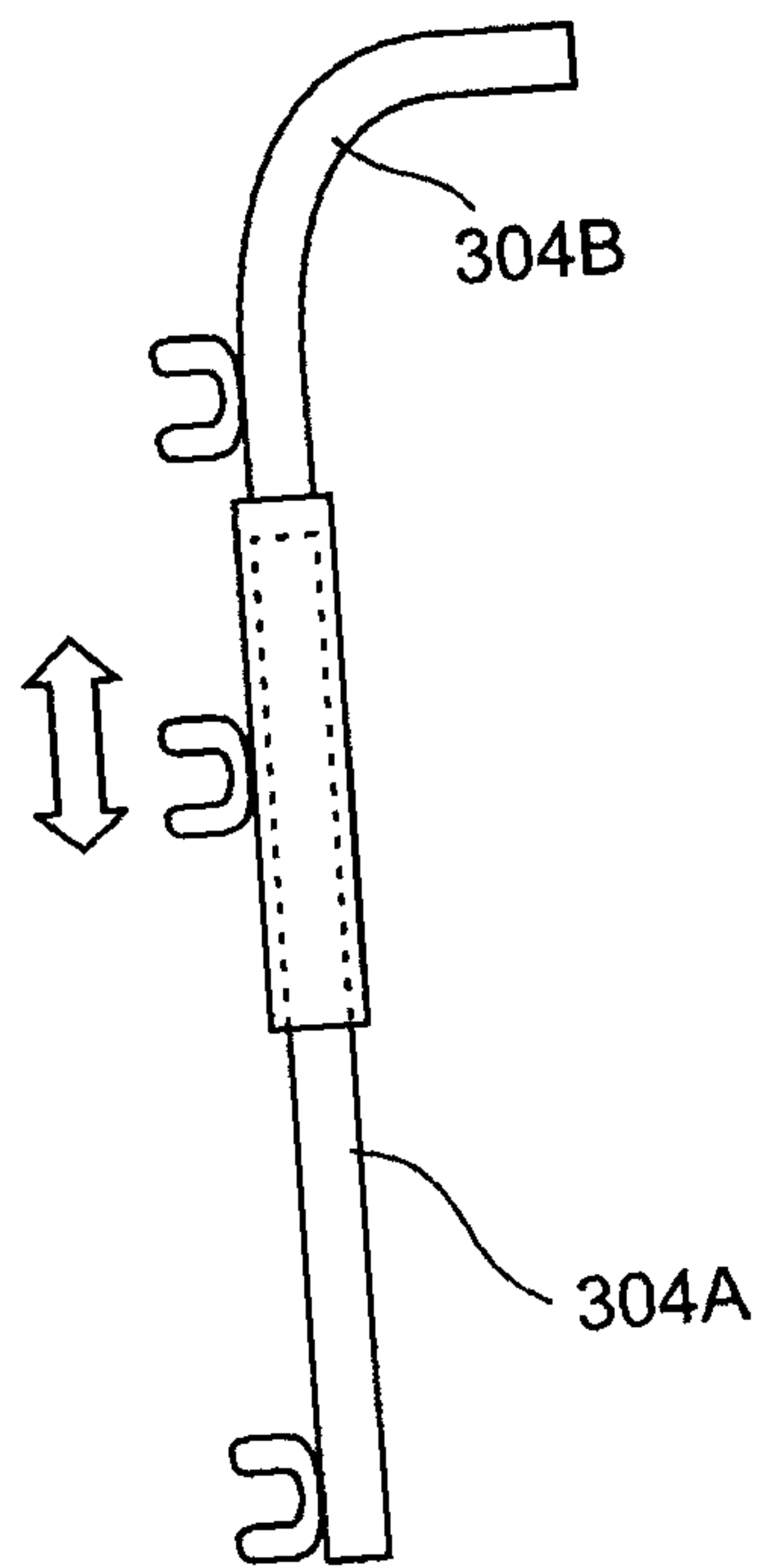

Figure. 4d

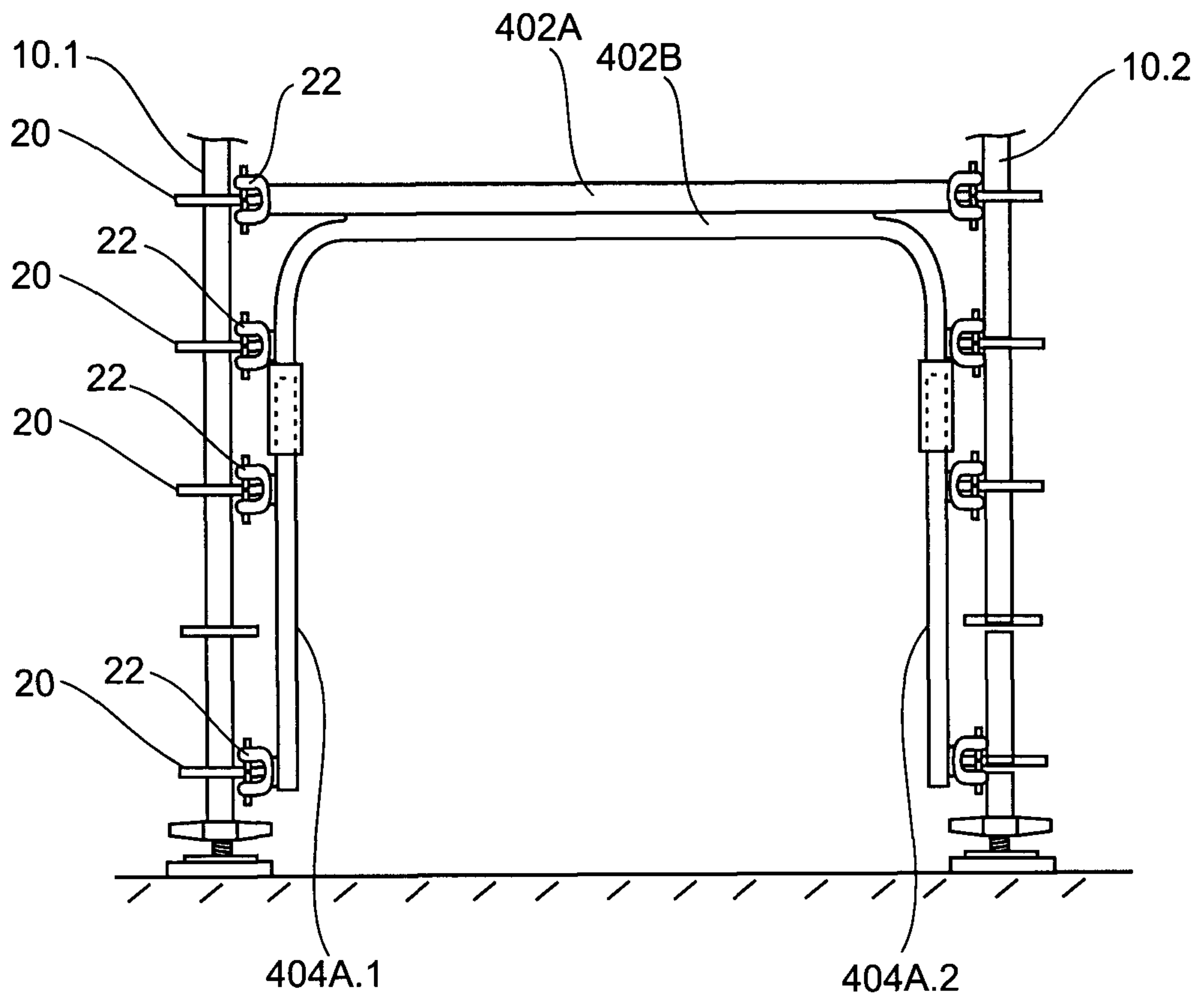

Figure. 5

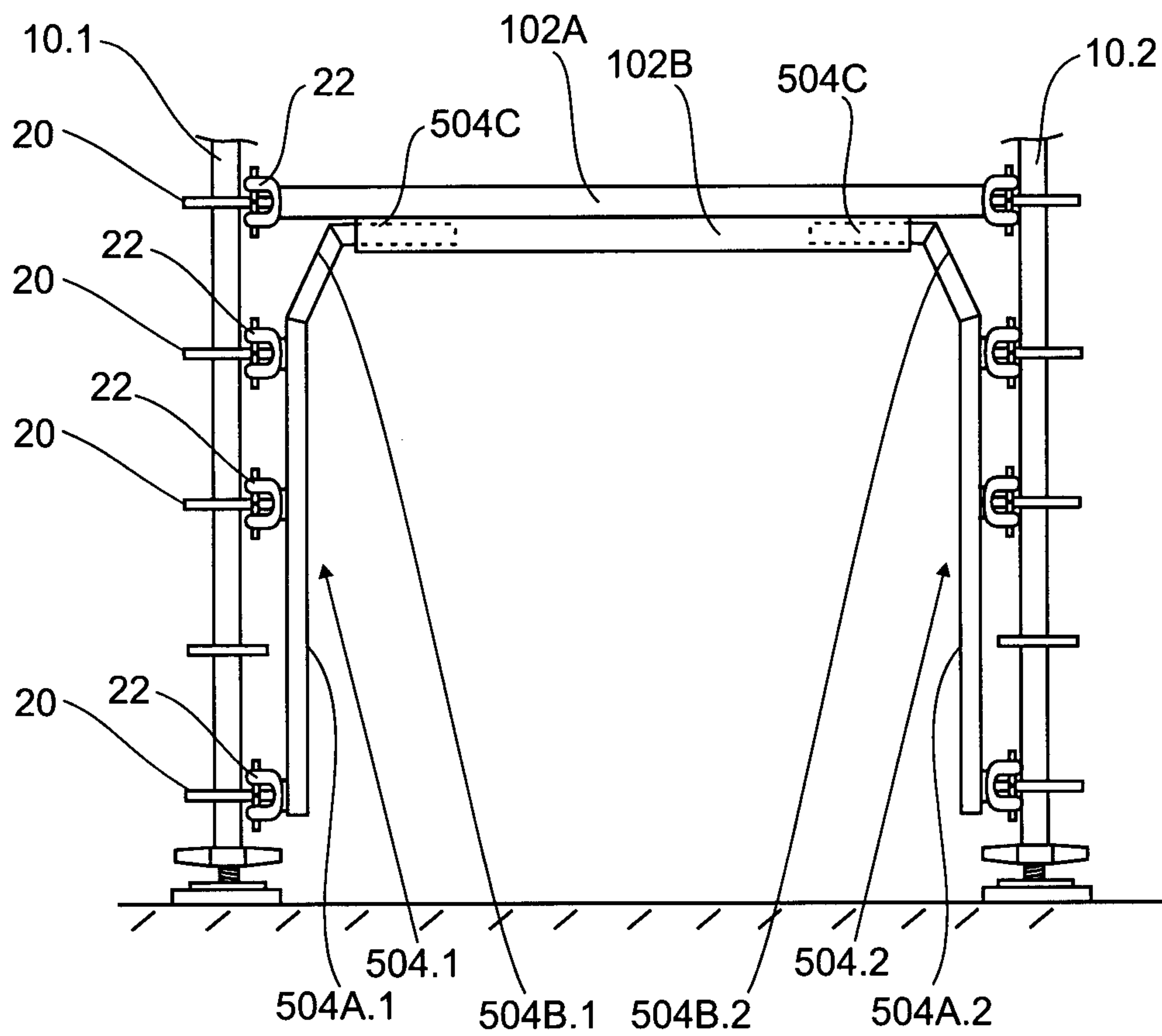

Figure. 6

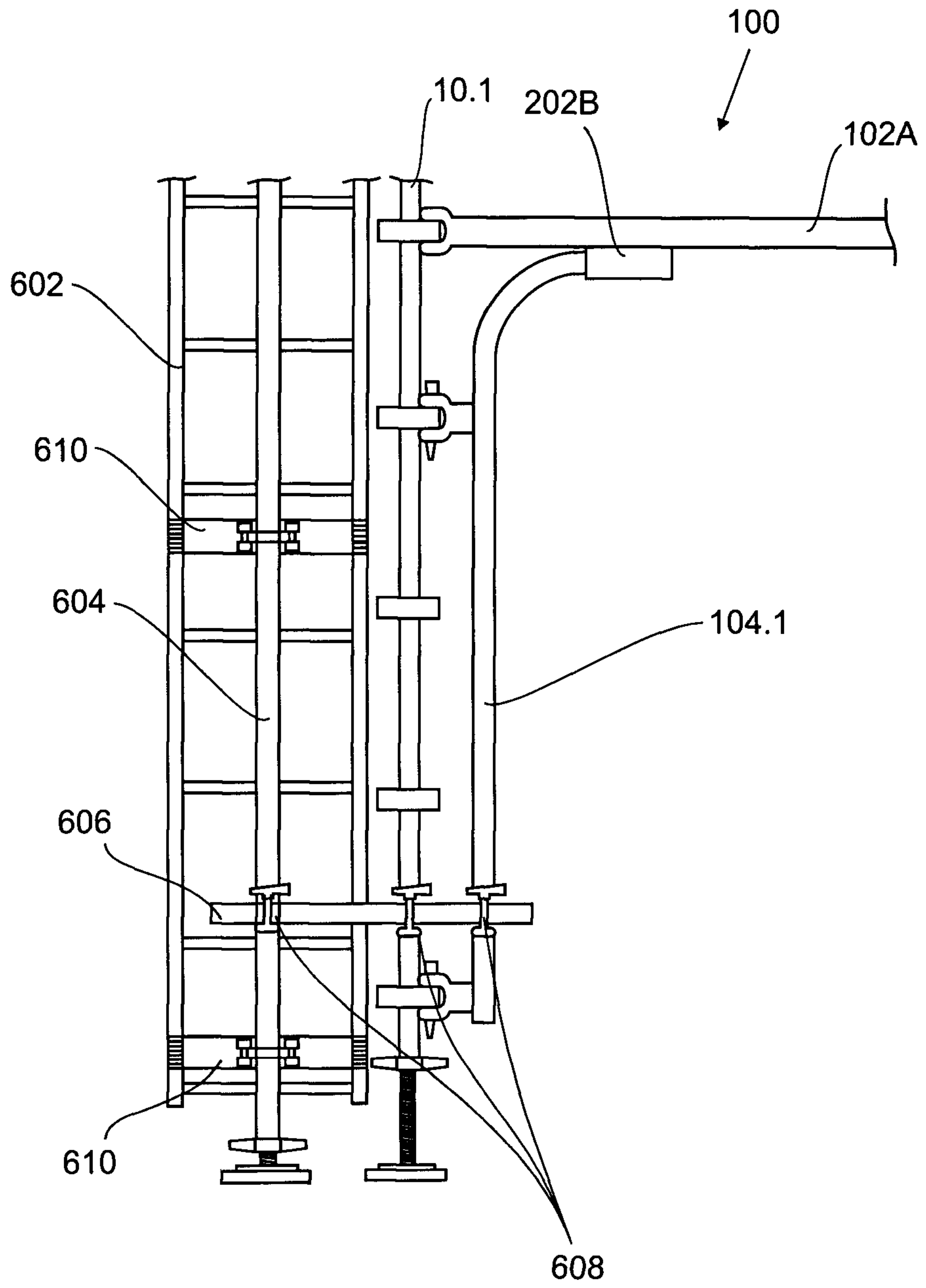

Figure. 7

