

(19) World Intellectual Property Organization
International Bureau



(43) International Publication Date
8 February 2001 (08.02.2001)

PCT

(10) International Publication Number
WO 01/09535 A1

- (51) International Patent Classification⁷: F16J 15/18, (74) Agent: TORRES, Carlos, A.; Browning Bushman, Suite 15/26, 15/28, 15/30 1800, 5718 Westheimer Road, Houston, TX 77057 (US).
- (21) International Application Number: PCT/US00/20582 (81) Designated States (*national*): CA, JP, MX.
- (22) International Filing Date: 28 July 2000 (28.07.2000) (84) Designated States (*regional*): European patent (AT, BE, CH, CY, DE, DK, ES, FI, FR, GB, GR, IE, IT, LU, MC, NL, PT, SE).
- (25) Filing Language: English
- (26) Publication Language: English
- (30) Priority Data:
09/366,521 3 August 1999 (03.08.1999) US
- (71) Applicant: UTEX INDUSTRIES, INC. [US/US]; Suite 100, 10810 Old Katy Road, Houston, TX 77043 (US).
- (72) Inventor: PIPPERT, Frederick, B.; 2514 Union Chapel Street, Sugar Land, TX 77479 (US).

Published:

- With international search report.
- Before the expiration of the time limit for amending the claims and to be republished in the event of receipt of amendments.

For two-letter codes and other abbreviations, refer to the "Guidance Notes on Codes and Abbreviations" appearing at the beginning of each regular issue of the PCT Gazette.

(54) Title: PACKING CARTRIDGE SEAL ASSEMBLY

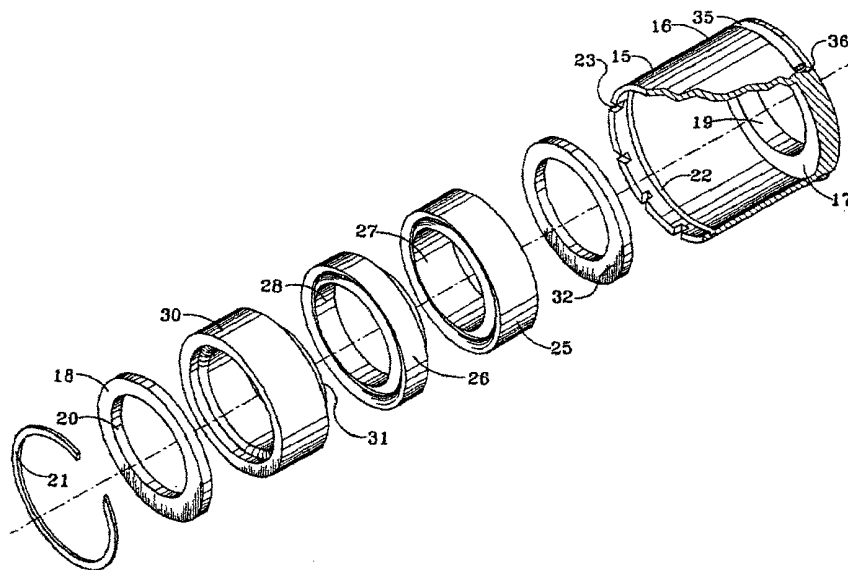

(57) Abstract: An assembly of packing seals (25 and 26) is contained in a cartridge (10). The cartridge is installed in the annular opening between a shaft (12) and a housing (11) to prevent leakage through the opening. One embodiment axially compresses the seals between spaced flanges (18 and 19) to urge the seals radially into sealing engagement with the shaft. Another embodiment employs a resilient biasing component placed between the flanges to increase and stabilize the axial seal compression (30). Pre-assembling the seals in the cartridge ensures proper packing arrangement and compression and reduces the time and effort required to install and remove individual seals.



WO 01/09535 A1

PACKING CARTRIDGE SEAL ASSEMBLY

Background of the Invention

Field of the Invention

5 The present invention relates generally to sealing means employed to prevent leakage between two relatively movable components. In a specific application, the present invention relates to a packing seal cartridge to prevent leakage between a reciprocating and/or rotatable shaft and a surrounding housing body.

10 Prior Art Setting of the Invention

 The opening through which a shaft enters a housing or chamber is typically sealed with annular packing rings that bridge the gap between the housing and the shaft. An example of this type of seal arrangement is illustrated in my U.S. Patent No. 4,991,857, incorporated herein by reference. The packing rings are positioned coaxially over the shaft and compressed into a surrounding retaining structure, or stuffing box, rigidly
15 connected to the housing. The packing ring opening is typically smaller than the shaft diameter so that the packing ring tightly engages the shaft when it is placed about the shaft. Axially compressing the packing rings into the stuffing box also increases the radial pressure exerted by the packing against the shaft.

20 Correct installation of the packing about the shaft requires that individual packing rings of the required size and type be placed over the shaft and inserted into the stuffing box. The rings must be properly oriented, and each different type ring must be inserted in its appropriate sequence. Where the packing rings are activated by axial compression, the proper compression force must be applied to the packing to achieve
25 optimum sealing effectiveness.

 The need to install individual packing rings and the requirement for proper ring compression can make the task of replacing worn packing difficult and time-consuming. Improper orientation of the packing seal, selection of an incorrect or defective replacement seal, failure to position a packing ring in the correct position or in the proper
30 order, damage to the seal ring during installation, improper compression adjustment, and other installation hazards can prevent the seal assembly from functioning properly.

-2-

Summary of the Invention

A packing cartridge seal assembly is equipped with packing contained within a rigid annular mount that can be placed over a relatively movable shaft to provide a seal with a surrounding housing. The packing extends inwardly from the central opening of the cartridge seal assembly to firmly engage the encircled shaft. An external seal carried on the outer wall of the cartridge assembly seals the cartridge assembly to the housing.

The individual packing elements within the cartridge are properly oriented, positioned, and compressed axially to provide the desired sealing engagement with the shaft.

In one form of the invention, resilient spring members are contained within the cartridge housing to apply the desired axial compression to the packing rings.

The packing cartridge seal assembly is provided with axially spaced, rigid flanges that confine the packing element and provide support for axial compression of the packing element. One of the flanges may be removed from the cartridge to permit assembly of the cartridge seal rings and axial biasing member.

From the foregoing, it will be appreciated that a primary object of the present invention is to provide a packing cartridge seal assembly that may be quickly and easily installed in, or removed from, sealing engagement between a rotatable and/or reciprocating shaft and a surrounding housing body.

Another object of the present invention is to provide a preassembled set of packing seals wherein the seal type, orientation, placement, and axial compression are preset before installation into sealing engagement between a rotatable shaft and a surrounding housing.

Yet another object of the present invention is to provide a packing seal cartridge assembly that can be stacked with similar cartridge assemblies to seal a relatively movable shaft with a surrounding housing.

Still another object of the invention is to provide a packing cartridge seal assembly having resilient spring biasing members for exerting a continuous, preset axial compression force on the seal members in the cartridge.

It is also an object of the present invention to provide a packing cartridge seal assembly in which the seal elements and axial biasing member of the assembly are

specially contoured to maximize the radial sealing forces exerted by the seal assembly against the shaft to improve the sealing ability of the assembly.

The foregoing, as well as other, objects, features, and advantages of the present invention will be more fully understood and appreciated by reference to the following
5 drawings, specification, and claims.

Brief Description of the Drawings

Figure 1 is a partial elevation, partially in section, illustrating a packing cartridge seal assembly of the present invention equipped with an elastomeric spring member
10 providing axial seal compression;

Figure 2 is an exploded view, in perspective, illustrating details in the construction of the packing cartridge seal assembly of Figure 1;

Figure 3 is a partial elevation, partially in section, illustrating a modified packing cartridge seal assembly of the present invention equipped with multi-coil spring members
15 providing axial seal compression;

Figure 4 is a partial elevation, partially in section, illustrating a modified packing seal assembly of the present invention equipped with multi-coil spring members providing axial compression against braided seal components;

Figure 5 is a partial elevation, partially in section, illustrating a modified packing
20 seal assembly of the present invention equipped with a single coaxial multi-coil spring member providing axial seal compression;

Figure 6 is a partial elevation, partially in section, illustrating a modified packing seal assembly of the present invention equipped with wave spring members providing axial seal compression; and

25 Figure 7 is a partial elevation, partially in section, illustrating stacked packing seal assemblies of the present invention.

Description of the Illustrated Embodiments

A packing seal assembly of the present invention is indicated generally at 10 in
30 Figure 1 disposed between a stuffing box 11 and a movable shaft 12. The stuffing box 11 may surround the opening through a pump housing or other structure (not illustrated) through which the shaft 12 communicates with a driven or driving device. The shaft 12

-4-

may rotate and/or reciprocate axially through the stuffing box, which is fixed to the pump housing. The cartridge seal assembly 10 is held in position within the stuffing box 11 by a gland follower 13 that is also secured to the pump housing.

5 The seal cartridge 10 functions to prevent leakage through the stuffing box while permitting motion of the shaft 12. An access opening 14 provides lubricating oil or flushing water for protecting the sealing components of the cartridge 10. The access opening 14 is on the fluid-containing, or high pressure, side of the cartridge seal 10.

10 With reference jointly to Figures 1 and 2, the seal cartridge 10 employs an annular seal carrier 15 having an axially extending tubular body 16 disposed between axially spaced, radially inwardly extending flanges 17 and 18. Central openings 19 and 20 extend axially through the flanges 17 and 18, respectively. The flange 18 may be removed to facilitate the insertion or removal of the seal components, or packing body assembly, carried within the tubular body 16. To this end, the flange 18 is held in place within the tubular body 16 by a snap ring 21 received within a circular snap ring slot 22.

15 Radial slots 23 formed in the end of the tubular body 16 assist in conducting lubricating fluid to the packing body assembly contained within the cartridge.

The packing body assembly includes annular internal seals, or packing rings 25 and 26, carried coaxially in the cartridge 10 between the flanges 17 and 18. The seals 25 and 26 may be such as described in my previously noted U.S. Patent No. 4,991,857.

20 Central openings 27 and 28 extend axially through the seals 25 and 26, respectively. The internal surfaces of the seal openings are adapted to engage and seal against the outer cylindrical surface of the shaft 12.

An annular, elastomeric spring body 30 is compressed axially between the flanges 17 and 18. The spring body 30 exerts an axial force against the seals 25 and 26 urging them radially inwardly into firm sealing engagement with the shaft 12. The bearing surfaces between the spring body 30 and the seals 26 and 25 are V-shaped, chevron fashion, to enhance the radial expansion of the seals resulting from the axial compressive force exerted by the spring body 30. An annular orienting nose 31 extending from the center of the face of the spring member 30 assists in aligning and positioning the spring

25

30 and seal 26.

An annular, anti-extrusion bushing 32 positioned at the end of the seal 25 closely surrounds the shaft 12 to prevent the seal from being forced into the gap between the

-5-

central opening of the flange 17 and the outer cylindrical surface of the shaft 12. The diameter of the central opening through the bushing 31 is smaller than the diameter of the openings 19 and 20 of the cartridge 10.

5 An annular, external O-ring seal member 35 is carried in a circular slot 36 on the outer cylindrical surface of the cartridge 10 to provide sealing engagement with the surrounding stuffing box 11. In the uncompressed condition of the O-ring 35, the outer diameter of the O-ring extends beyond the outer diameter of the tubular cartridge body 16. Insertion of the cartridge 10 into the stuffing box 11 compresses the O-ring to seal the gap between the tubular body 16 and the surrounding internal wall of the stuffing box 11. Complete sealing of the annular space between the stuffing box 11 and the shaft 12 is thus effected by the external O-ring seal 35, the cartridge body 16, and the seals 27 and 28.

15 In operation, the cartridge 10 is preassembled by inserting the seal components into the tubular body 16 with the flange 18 removed. The various components of the seal are inserted in the order and with the orientation illustrated in Figures 1 and 2. With the seal components contained within the tubular body 16, the flange 18 is placed over the assembly and forced axially toward the flange 17, compressing the intermediate components. The snap ring 21 is then positioned in the groove 22 to hold the flange 17 in place. Proper selection of the components employed in the cartridge 10 ensures that the sealing elements are uniformly and properly compressed between the fixed flanges 20 17 and 18. The assembly process may be performed in the controlled environment of a manufacturing facility by experienced personnel employing proper components.

The preassembled cartridge 10 is placed over the shaft 12 and moved axially into proper engagement within the stuffing box 11. The gland follower 13 is then positioned 25 to hold the cartridge 10 in place within the stuffing box. These simple steps replace the multiple steps normally required to repack the stuffing box using individual seals and adjusting the compression of the seal members to achieve the desired radial seal with the shaft.

30 Figure 3 of the drawings illustrates a modified form of the packing cartridge seal assembly of the invention indicated generally at 40. The assembly 40 in Figure 3 is similar to the assembly illustrated in Figures 1 and 2. Identical components bear the same reference characters. Multiple springs 41 are employed to provide axial

-6-

compression of the sealing component contained between the two end flanges of the cartridge. A removable flange 42 is provided with axial pockets 43 that hold the springs 41 and align them for compressive engagement with a bottom adapter 44. The annular adapter 44 includes a square base and a V-shaped bearing surface engaging the seal 26.

5 Two or more springs 41 may be circumferentially disposed between the flange 42 and the bottom adapter 44 to uniformly apply the desired axial compression to the sealing members.

Figure 4 illustrates a modified form of the packing cartridge seal assembly of the present invention, indicated generally at 50, employing multiple, annular, square-ended, braided seal members 51, 52, and 53 separated by spacers 54 and 55. The compression springs 41 exert an axial compression force against an annular bottom adapter 56 to provide the desired axial and radial compression of the seal of members 51, 52, and 53.

10

Figure 5 illustrates yet another modified form of the packing cartridge seal assembly of the present invention indicated generally at 60. The packing rings 25 and 26 are compressed axially by a single, multi-coil spring 61 disposed coaxially with the shaft 12. The spring 61 exerts a biasing force between the flange 18 and a bottom adapter 62. The bearing face of the bottom adapter 62 is V-shaped to conform with the mating face of the seal 26 to increase the radial sealing force exerted by the seal rings.

15

Figure 6 illustrates a modified form of the packing cartridge seal assembly of the present invention indicated generally at 70. Annular wave rings 71 and 72 exert a compressive force between the flange 18 and the bottom adapter 62. The wave springs 71 and 72 may be fabricated from any suitable resilient metal or synthetic material.

20

Figure 7 illustrates another form of the invention, indicated generally at 80, in which multiple cartridges 81 and 82 are stacked over the shaft 12. Lubrication access openings 84 and 85 extending through a stuffing box 86 communicate lubricant to the packing material in the two cartridges through circumferentially spaced, radial openings 90 and 91 that extend, respectively, through the ends of the cartridges 81 and 82.

25

External O-ring seals 95 and 96 in the cartridges 81 and 82, respectively, are provided with back-up rings 97 and 98, respectively, to assist sealing of the annular gap between the external cylindrical surface of the cartridge bodies and the internal circular wall of the stuffing box opening. The back-up rings 95 and 96 are preferably formed in

30

-7-

a flat helical configuration with partially overlapping layers and may advantageously be constructed of Teflon or other suitable material.

While two cartridge assemblies have been illustrated in Figure 7, it may be appreciated that any number of cartridge seal assemblies may be stacked to provide the
5 desired seal between the stuffing box and the shaft. Similarly, it will be appreciated that any of the cartridge assemblies described herein may be stacked in the matter illustrated in Figure 7. As with the single cartridge applications, the stacked cartridge bodies isolate the compressed packing rings from the forces exerted by the packing gland follower 13. Uniform seal compression is maintained within the individual cartridges by the
10 compressive force effected between the end flanges of the cartridge.

The cartridge bodies described herein may preferably be constructed of a brass or other suitable bushing-like material. The materials making up the individual seal rings employed in the cartridge made be any suitable composition and configuration compatible with the fluid or pressure to be sealed between the stuffing box and shaft.
15 Thus, the seal rings may be of any suitable compressible material and may be circular in cross-section or may be oval, square, or of another cross-sectional shape. The annular seal members may be monolithic or may be of the split ring, flat helical, or other variety. The material of the seals may be synthetic, natural, or mixtures thereof. Various fillers may be employed in the seals, including synthetic polymeric materials such as nitriles,
20 fluorocarbon resins, or silicon resins, as well as combinations thereof.

While various preferred forms of a packing cartridge seal assembly have been described in detail herein, it may be appreciated that modifications of the Assemblies may be made without departing from the spirit and scope of the invention, which is more fully defined in the following claims.

-8-

Claims

1. A seal cartridge assembly for providing a seal between the external cylindrical surface of a cylindrical body member and the surrounding cylindrical walls of an opening through a separate body member, comprising:
- 5 an annular seal carrier having an axially extending tubular body disposed between first and second axially spaced, radially inwardly extending flanges;
- central openings extending axially through each of said first and second flanges, said central openings having a diameter no smaller than the external diameter of said cylindrical body;
- 10 an annular internal seal component carried coaxially in said cartridge between said first and second flanges, said seal component having a central axial opening with at least a portion of said central axial opening having a diameter that is smaller than the external diameter of said cylindrical body; and
- an annular external seal member connected with said tubular body, said external seal member having an external diameter greater than the internal diameter through said separate body.
- 15
2. The seal cartridge assembly as defined in Claim 1 wherein said internal seal component comprises:
- 20 a packing body assembly; and
- an axially compressed spring member resiliently compressing said packing body assembly between said first and second flanges whereby said packing body assembly is resiliently biased radially inwardly toward said central axial opening of said seal component.
- 25
3. The seal cartridge assembly as defined in Claim 1 wherein said first flange is removably secured to said seal carrier whereby said first flange may be secured to said seal carrier after said packing body assembly and said spring body are positioned in said seal cartridge.
- 30
4. The seal cartridge assembly as defined in Claim 2 wherein said seal component includes an annular extrusion ring disposed between said packing body

assembly and said second flange, said extrusion ring having a central opening having a diameter smaller than the central opening of said second flange.

- 5 5. The seal cartridge assembly as defined in Claim 2 wherein said packing body assembly comprises chevron packing.
6. The seal cartridge assembly as defined in Claim 3 wherein said first flange is secured to said seal carrier by a snap ring.
- 10 7. The seal cartridge assembly as defined in Claim 2 wherein said spring member comprises an annular body of elastomeric material.
8. The seal cartridge assembly as defined in Claim 7 wherein said packing body assembly comprises chevron packing.
- 15 9. The seal cartridge assembly as defined in Claim 8 wherein said annular body of elastomeric material is contoured with a chevron face to mate with a chevron face of said chevron packing whereby axial force exerted by said annular body urges said chevron packing to expand radially.
- 20 10. The seal cartridge assembly as defined in Claim 9 wherein said chevron face on said annular body of elastomeric material is provided with an annular engagement ridge that mates with an annular engagement recess in said chevron face of said chevron packing.
- 25 11. The seal cartridge assembly as defined in Claim 1 wherein said external seal member includes an annular, elastomeric seal ring carried in an annular groove in said tubular body.
- 30 12. The seal cartridge assembly as defined in Claim 11 wherein said external seal member further includes a helical backup ring carried in said annular groove.

-10-

13. The seal cartridge assembly as defined in Claim 1 wherein said seal cartridge assembly further includes radially opening lubrication ports for communicating lubricant to said packing assembly.

5 14. The seal cartridge assembly as defined in Claim 2 wherein said spring member comprises a plurality of circumferentially spaced, multicoil, helically wound spring bodies disposed between said first and second flanges.

10 15. The seal cartridge assembly as defined in Claim 2 wherein said spring member comprises a multicoil, helically wound spring having its central helical axis substantially coincident with the central axis of said seal cartridge.

15 16. The seal cartridge assembly as defined in Claim 2 wherein said spring member comprises one or more wave springs disposed between said first and second flanges concentrically with said seal cartridge.

20 17. The seal cartridge assembly as defined in Claim 2 wherein said external seal member includes an annular, elastomeric seal ring carried in an annular groove in said tubular body.

18. The seal cartridge assembly as defined in Claim 17 wherein said seal cartridge assembly further includes radially opening lubrication ports for communicating lubricant to said packing assembly.

25 19. The seal cartridge assembly as defined in Claim 17 wherein said first flange is removably secured to said seal carrier whereby said first flange may be secured to said seal carrier after said packing body assembly and said spring body are positioned on said seal cartridge.

30 20. The seal cartridge assembly as defined in Claim 19 wherein said seal component includes an annular extrusion ring disposed between said packing body

assembly and said second flange, said extrusion ring having a central opening having a diameter smaller than the central opening of said second flange.

5 21. A seal cartridge assembly for sealing between relatively movable members, comprising:

a first cylindrical body member and a second separate body member, said first and second body members being relatively movable, said first member having an axially extending external cylindrical surface received within an axially extending cylindrical wall opening of said second member and defining an annular space between said first and
10 second members;

an annular seal carrier sealingly disposed in said annular space between said first and second members, said seal carrier having an axially extending tubular body disposed between first and second axially spaced, radially inwardly extending flanges;

central openings extending axially through each of said first and second flanges,
15 said central openings having a diameter no smaller than the external diameter of said cylindrical body;

an annular internal seal component carried coaxially in said cartridge between said first and second flanges, said seal component having a central axial opening with at least a portion of said central axial opening having a diameter that is substantially the
20 same as the external diameter of said cylindrical body whereby said seal component forms a seal between said cylindrical body and said tubular body of said seal carrier; and

an annular external seal member connected with said tubular body for sealing said tubular body to the wall opening of said second member.

25 22. The seal cartridge assembly as defined in Claim 21 wherein said internal seal component comprises:

a packing body assembly; and

an axially compressed spring member resiliently compressing said packing body assembly between said first and second flanges whereby said packing body assembly is
30 resiliently biased radially inwardly toward said central axial opening of said seal component.

-12-

23. The seal cartridge assembly as defined in Claim 21 wherein said first flange is removably secured to said seal carrier whereby said first flange may be secured to said seal carrier after said packing body assembly and said spring body are positioned in said seal cartridge.

5

24. The seal cartridge assembly as defined in Claim 22 wherein said seal component includes an annular extrusion ring disposed between said packing body assembly and said second flange, said extrusion ring having a central opening having a diameter smaller than the central opening of said second flange.

10

25. The seal cartridge assembly as defined in Claim 22 wherein said packing body assembly comprises chevron packing.

26. The seal cartridge assembly as defined in Claim 23 wherein said first flange is secured to said seal carrier by a snap ring.

15

27. The seal cartridge assembly as defined in Claim 22 wherein said spring member comprises an annular body of elastomeric material.

28. The seal cartridge assembly as defined in Claim 27 wherein said packing body assembly comprises chevron packing.

20

29. The seal cartridge assembly as defined in Claim 28 wherein said annular body of elastomeric material is contoured with a chevron face to mate with a chevron face of said chevron packing whereby axial force exerted by said annular body urges said chevron packing to expand radially.

25

30. The seal cartridge assembly as defined in Claim 29 said chevron face on said ring is provided with an annular engagement ridge that mates with annular engagement recesses in said chevron face of said chevron packing.

30

31. The seal cartridge assembly as defined in Claim 21 wherein said external seal member includes an annular, elastomeric seal ring carried in an annular groove in said tubular body.

5 32. The seal cartridge assembly as defined in Claim 31 wherein said external seal member further includes a helical backup ring carried in said annular groove.

33. The seal cartridge assembly as defined in Claim 21 wherein said seal cartridge assembly further includes radially opening lubrication ports for communicating
10 lubricant to said packing assembly.

34. The seal cartridge assembly as defined in Claim 22 wherein said spring member comprises a plurality of circumferentially spaced, multicoil, helically wound spring bodies disposed between said first and second flanges.
15

35. The seal cartridge assembly as defined in Claim 22 wherein said spring member comprises a multicoil, helically wound spring having its central helical axis substantially coincident with the central axis of said seal cartridge.

20 36. The seal cartridge assembly as defined in Claim 22 wherein said spring member comprises one or more wave springs disposed between said first and second flanges concentrically with said seal cartridge.

37. The seal cartridge assembly as defined in Claim 22 wherein said external
25 seal member includes an annular, elastomeric seal ring carried in an annular groove in said tubular body.

38. The seal cartridge assembly as defined in Claim 27 wherein said seal
30 cartridge assembly further includes a mechanical engagement structure for holding said seal carrier stationary relative to said separate body.

39. The seal cartridge assembly as defined in Claim 27 wherein said first flange is removably secured to said seal carrier whereby said first flange may be secured to said seal carrier after said packing body assembly and said spring body are positioned in said seal cartridge.

5

40. The seal cartridge assembly as defined in Claim 29 wherein said seal component includes an annular extrusion ring disposed between said packing body assembly and said second flange, said extrusion ring having a central opening having a diameter smaller than the central opening of said second flange.

10

41. The seal cartridge assembly as defined in Claim 21, further comprising multiple seal cartridge assemblies coaxially stacked in said annular space between said first and second members.

15

42. The seal cartridge assembly as defined in Claim 22, further comprising multiple seal cartridge assemblies coaxially stacked in said annular space between said first and second members.

20

43. The seal cartridge assembly as defined in Claim 23, further comprising multiple seal cartridge assemblies coaxially stacked in said annular space between said first and second members.

25

44. The seal cartridge assembly as defined in Claim 24, further comprising multiple seal cartridge assemblies coaxially stacked in said annular space between said first and second members.

30

45. The seal cartridge assembly as defined in Claim 31, further comprising multiple seal cartridge assemblies coaxially stacked in said annular space between said first and second members.

-15-

46. The seal cartridge assembly as defined in Claim 33, further comprising multiple seal cartridge assemblies coaxially stacked in said annular space between said first and second members.

5 47. The seal cartridge assembly as defined in Claim 21, further including an access opening through said second body member for supplying fluid to said first body member.

10 48. The seal cartridge assembly as defined in Claim 1, further including an access opening through said second body member for supplying fluid to said first body member.

15 49. The seal cartridge assembly as defined in Claim 21, further including an access opening through said second body member for supplying fluid to said first body member.

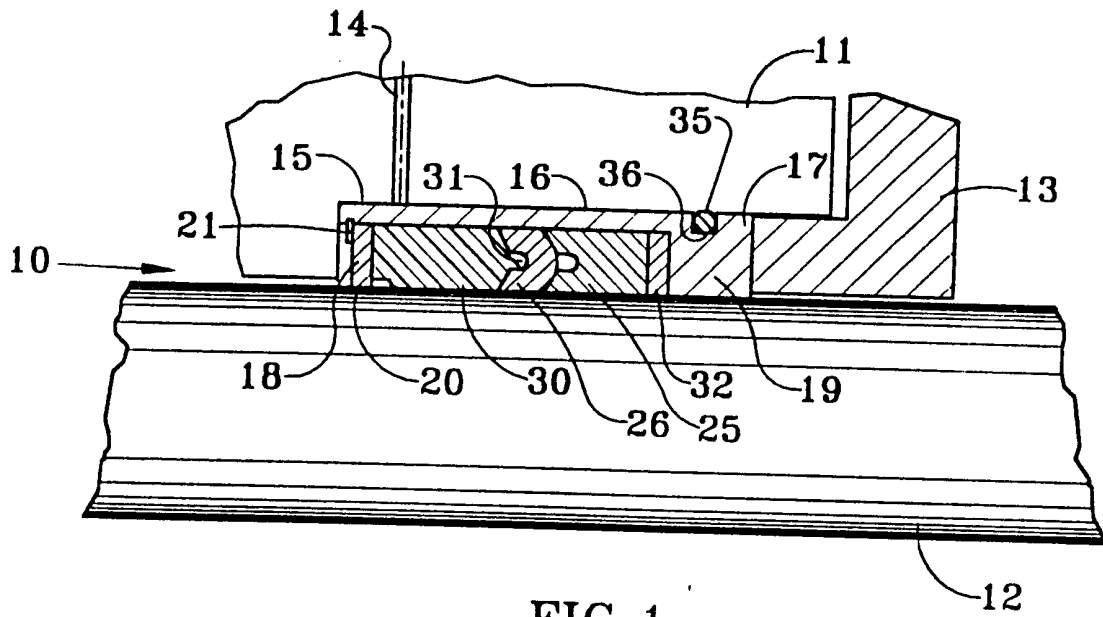

FIG. 1

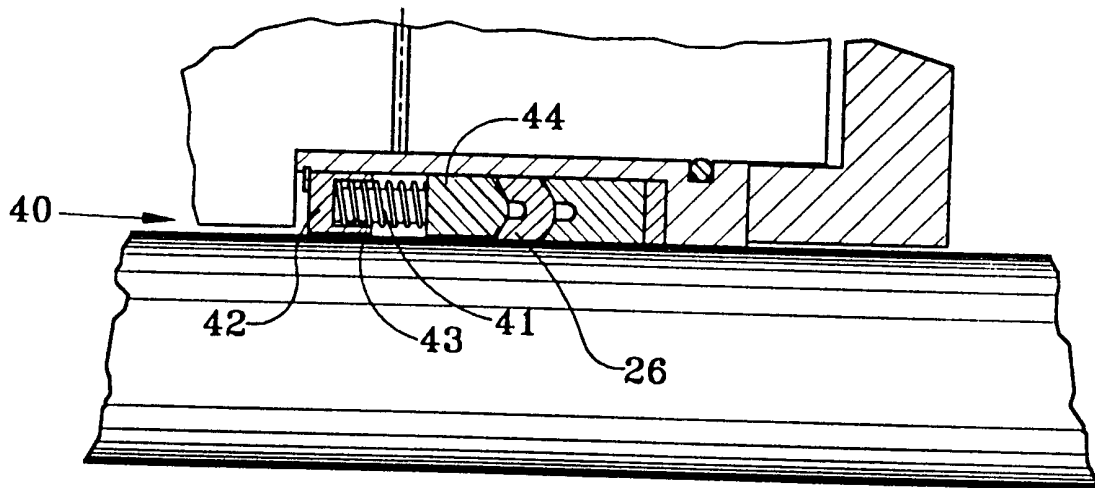

FIG. 3

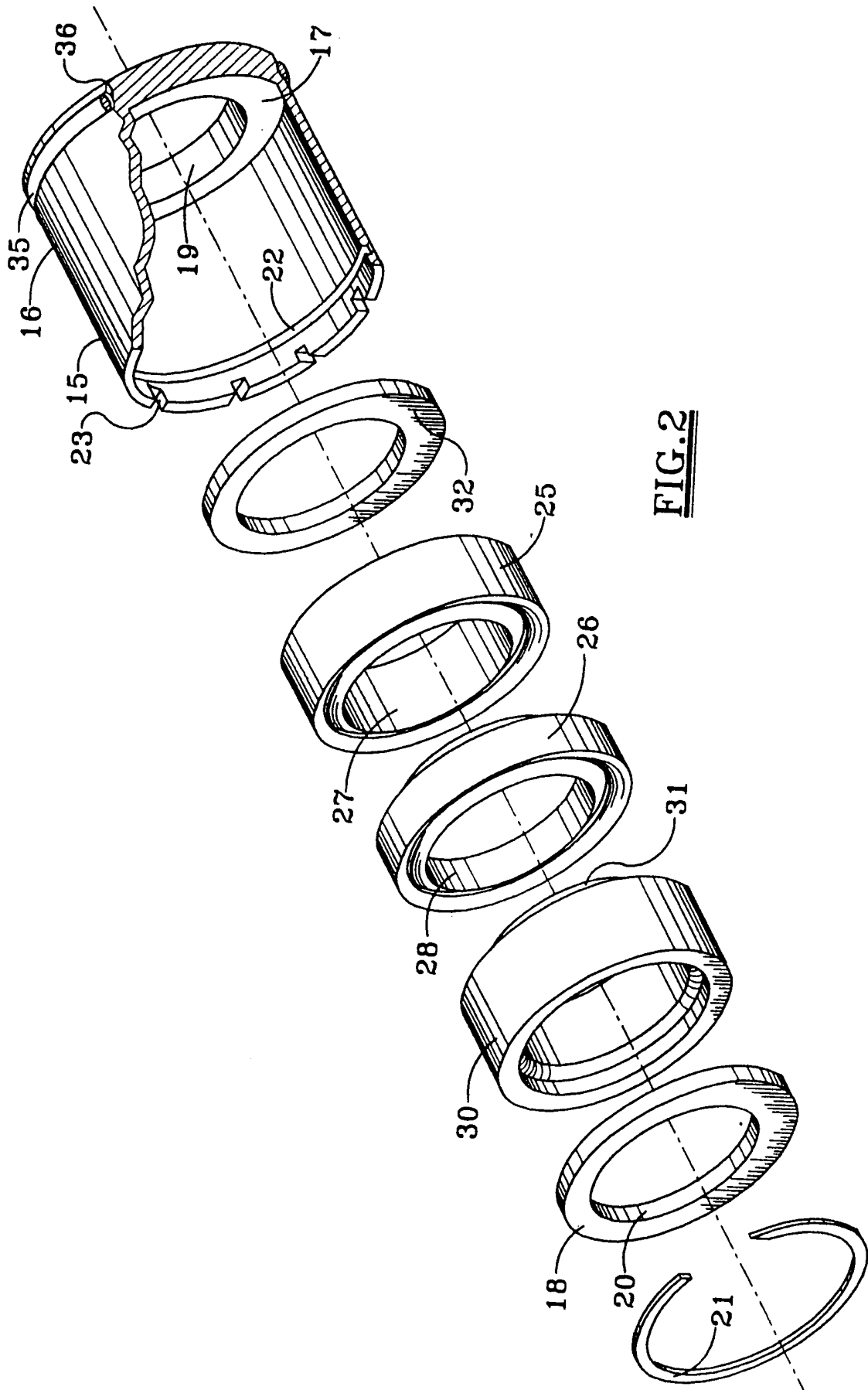
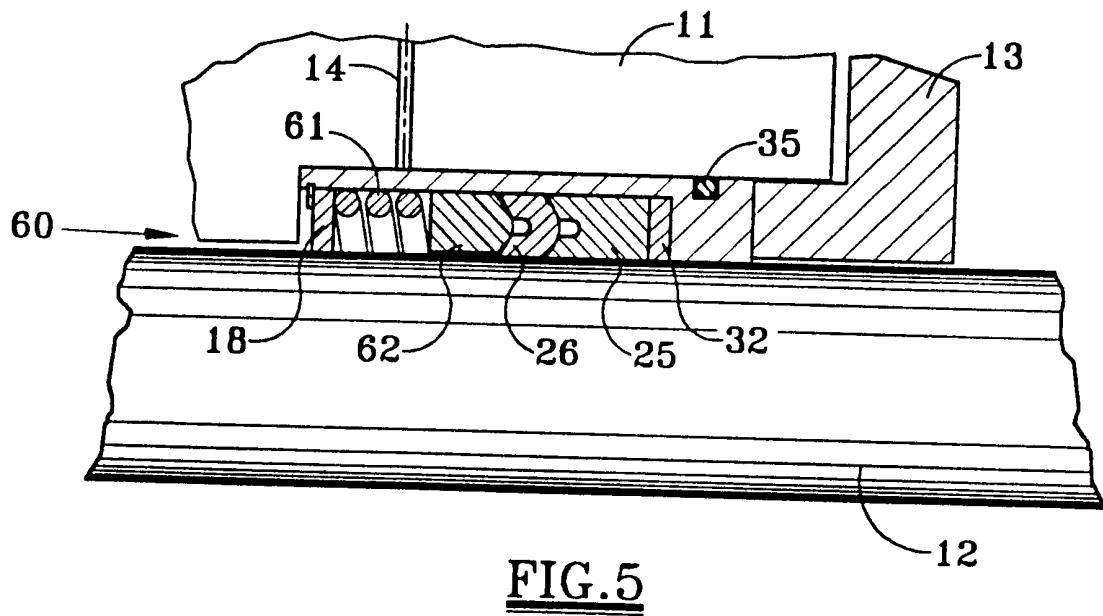
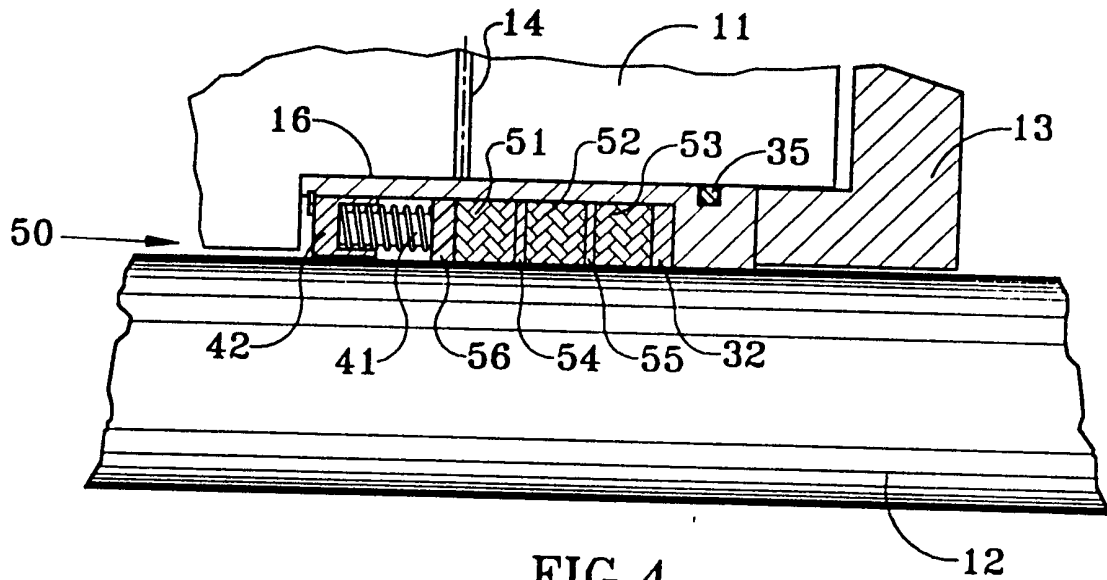

FIG.2



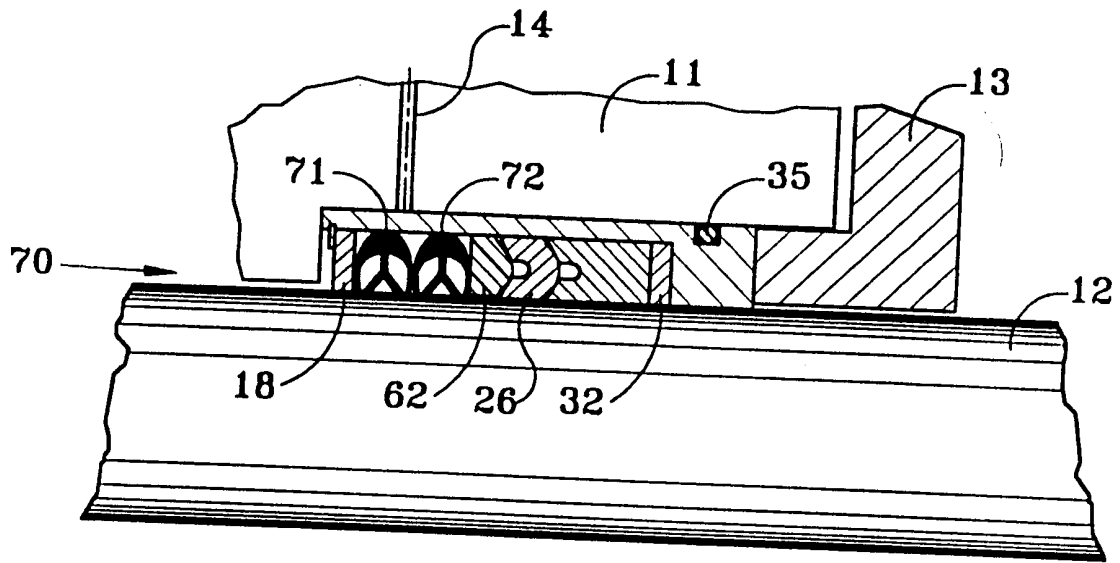

FIG. 6

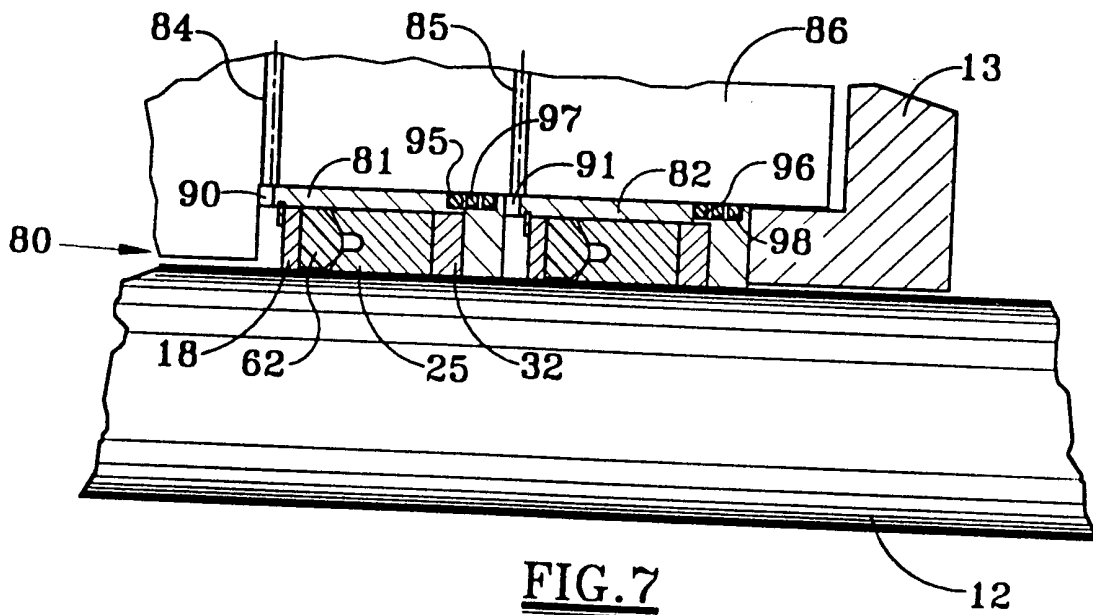

FIG. 7

INTERNATIONAL SEARCH REPORT

International application No.

PCT/US00/20582

A. CLASSIFICATION OF SUBJECT MATTER

IPC(7) : F16J 15/18, 15/26, 15/28, 15/30
 US CL : 277/510, 511, 512, 516, 517, 518, 520, 522, 529, 530, 531, 532, 534, 537, 540

According to International Patent Classification (IPC) or to both national classification and IPC

B. FIELDS SEARCHED

Minimum documentation searched (classification system followed by classification symbols)
 U.S. : 277/510, 511, 512, 516, 517, 518, 520, 522, 529, 530, 531, 532, 534, 537, 540

Documentation searched other than minimum documentation to the extent that such documents are included in the fields searched

Electronic data base consulted during the international search (name of data base and, where practicable, search terms used)

C. DOCUMENTS CONSIDERED TO BE RELEVANT

Category *	Citation of document, with indication, where appropriate, of the relevant passages	Relevant to claim No.
X	US 5,263,682 A (Covert et al) 23 November 1993 (23.11.1993), See figure 3.	1-3
X	US 4630636 A (Cutcher) 23 December 1986 (23.12.1986), See entire document.	1-8, 11, 21-28 and 37-39

Y		----- 9-10, 14, 16, 29-30, 34, 36 and 41-46
Y	US 3,419,280 A (Wheeler) 31 December 1968 (31.12.1968), See all figures and entire document.	9-10, 29-30 and 41-46
Y	US 1,013,745 A (Clark) 2 January 1912 (02.01.1912), See all figures.	14 and 34
Y	US 3,588,126 A (McKillop) 28 June 1971 (28.06.1971), See entire document.	16 and 36
Y	US 3,907,307 A (Maurer et al) 23 September 1975 (23.09.1975), See entire document.	1, 12, 15, 17-22, 32, 33, 35, 37-40 and 47-49
Y	US 3,366,425 A (Genz) 30 January 1968 (30.01.1968), See column 6, lines 21-36.	1, 12, 15, 17-22, 32, 33, 35, 37-40 and 47-49
Y	US 5,062,397 A (Larson) 5 November 1991 (.05.11.1991), See entire document.	12 and 32
A	US 4,135,546 A (Morrison) 23 January 1979 (23.01.1979), See entire document.	1-49
A	US 3,833,228 A (Gilliam Sr.) 3 September 1974 (03.09.1974), See entire document.	1-49



Further documents are listed in the continuation of Box C.



See patent family annex.

* Special categories of cited documents:	"T"	later document published after the international filing date or priority date and not in conflict with the application but cited to understand the principle or theory underlying the invention
"A" document defining the general state of the art which is not considered to be of particular relevance	"X"	document of particular relevance; the claimed invention cannot be considered novel or cannot be considered to involve an inventive step when the document is taken alone
"E" earlier application or patent published on or after the international filing date	"Y"	document of particular relevance; the claimed invention cannot be considered to involve an inventive step when the document is combined with one or more other such documents, such combination being obvious to a person skilled in the art
"L" document which may throw doubts on priority claim(s) or which is cited to establish the publication date of another citation or other special reason (as specified)	"&"	document member of the same patent family
"O" document referring to an oral disclosure, use, exhibition or other means		
"P" document published prior to the international filing date but later than the priority date claimed		

Date of the actual completion of the international search

23 October 2000 (23.10.2000)

Date of mailing of the international search report

28 DEC 2000

Name and mailing address of the ISA/US
 Commissioner of Patents and Trademarks
 Box PCT
 Washington, D.C. 20231

Facsimile No. (703)305-3230

Authorized officer

Vishal Patel

Telephone No. 703-308-8495

INTERNATIONAL SEARCH REPORT

International application No.

PCT/US00/20582

C (Continuation) DOCUMENTS CONSIDERED TO BE RELEVANT

Category*	Citation of document, with indication, where appropriate, of the relevant passages	Relevant to claim No.
A	US 4,398,731 A (Gorman et al.) 16 August 1983 (16.08.1983), See entire document.	1-49
A	US 3,351,531 A (Maasberg et al.) 28 September 1982 (28.09.1982), See entire document.	1-49
A	US 3,655,204 A (Sievenpiper) 11 April 1972 (11.04.1972), See entire document.	1-49