



US 20070251256A1

(19) **United States**

(12) **Patent Application Publication**  
**Pham et al.**

(10) **Pub. No.: US 2007/0251256 A1**

(43) **Pub. Date: Nov. 1, 2007**

(54) **FLASH TANK DESIGN AND CONTROL FOR HEAT PUMPS**

**Publication Classification**

(76) Inventors: **Hung M. Pham**, Dayton, OH (US);  
**Jean-Luc M. Caillat**, Dayton, OH (US);  
**Ronald L. Van Hoose**, Huber Heights, OH (US)

(51) **Int. Cl.**  
**F25B 13/00** (2006.01)  
(52) **U.S. Cl.** ..... **62/324.1; 220/565**

(57) **ABSTRACT**

Correspondence Address:  
**HARNESS, DICKEY & PIERCE, P.L.C.**  
**P.O. BOX 828**  
**BLOOMFIELD HILLS, MI 48303 (US)**

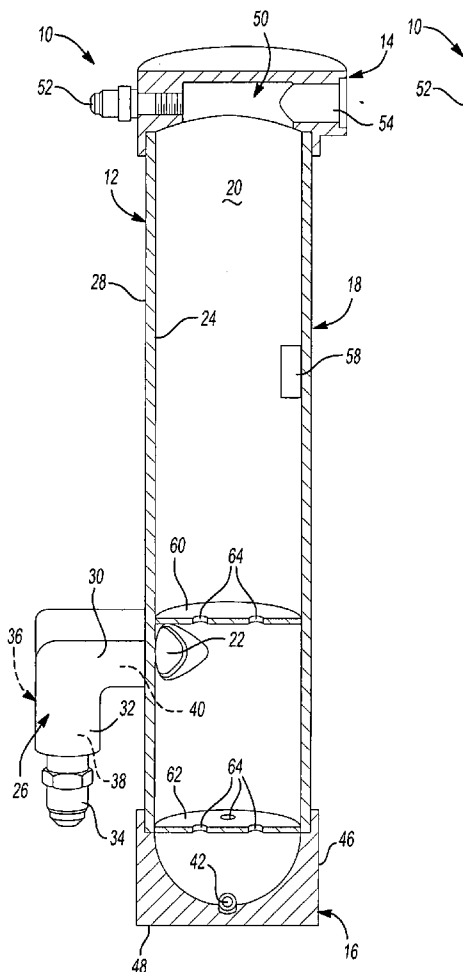
A flash tank for a heat pump operable in a heating mode and a cooling mode includes a shell having a middle portion disposed between a top portion and a bottom portion, with the top portion, bottom portion, and middle portion cooperating to define an inner volume of the shell. A first port is in fluid communication with the inner volume and functions as an inlet in the heating mode and as an outlet in the cooling mode. A second port is in fluid communication with the inner volume and functions as an inlet in the cooling mode and as an outlet in the heating mode. Flow control devices and check valves are fluidly coupled to control the tank as a flash tank in heating mode and as a receiver in cooling mode.

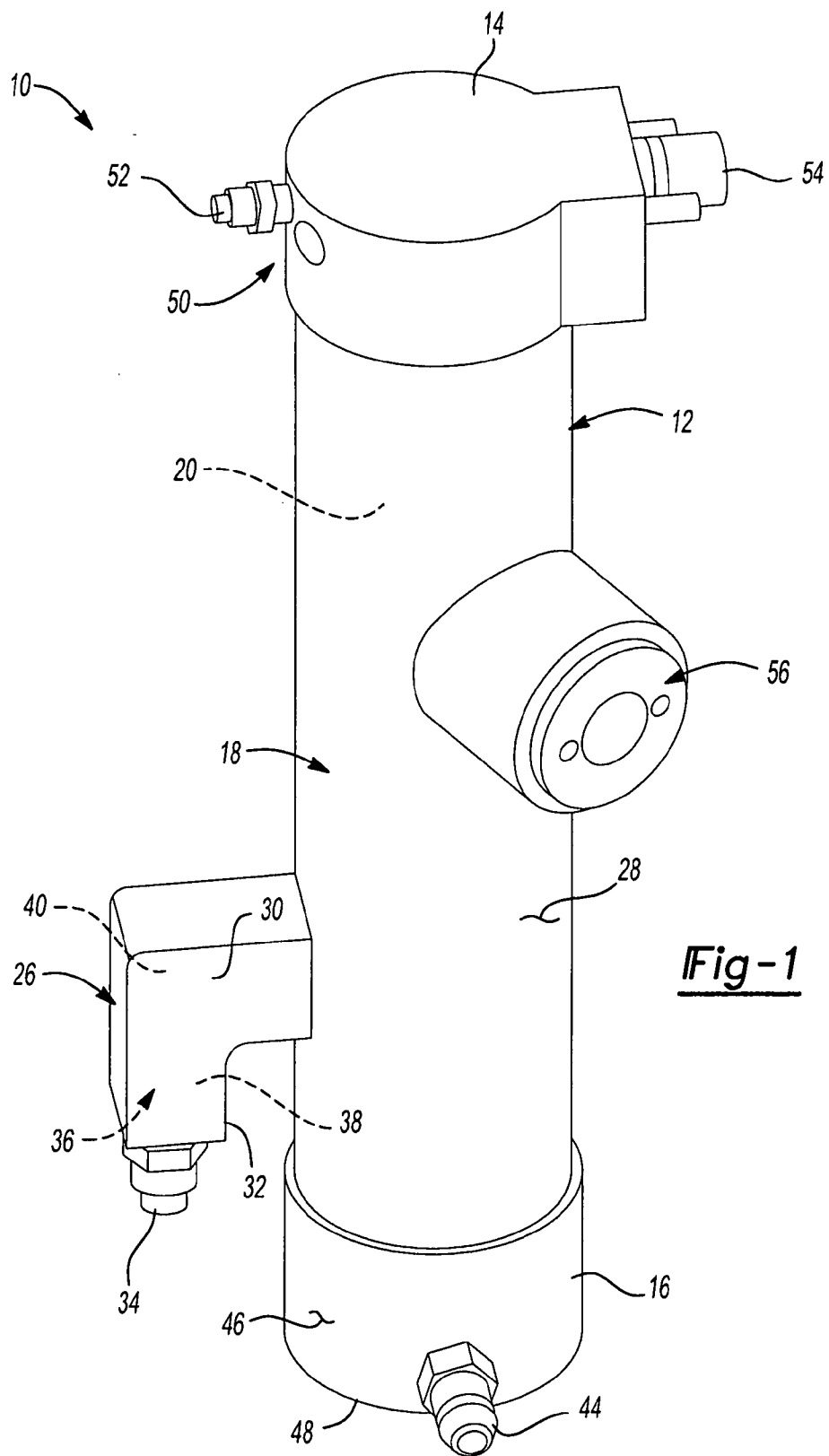
(21) Appl. No.: **11/725,557**

(22) Filed: **Mar. 19, 2007**

**Related U.S. Application Data**

(60) Provisional application No. 60/784,145, filed on Mar. 20, 2006.





**Fig-1**

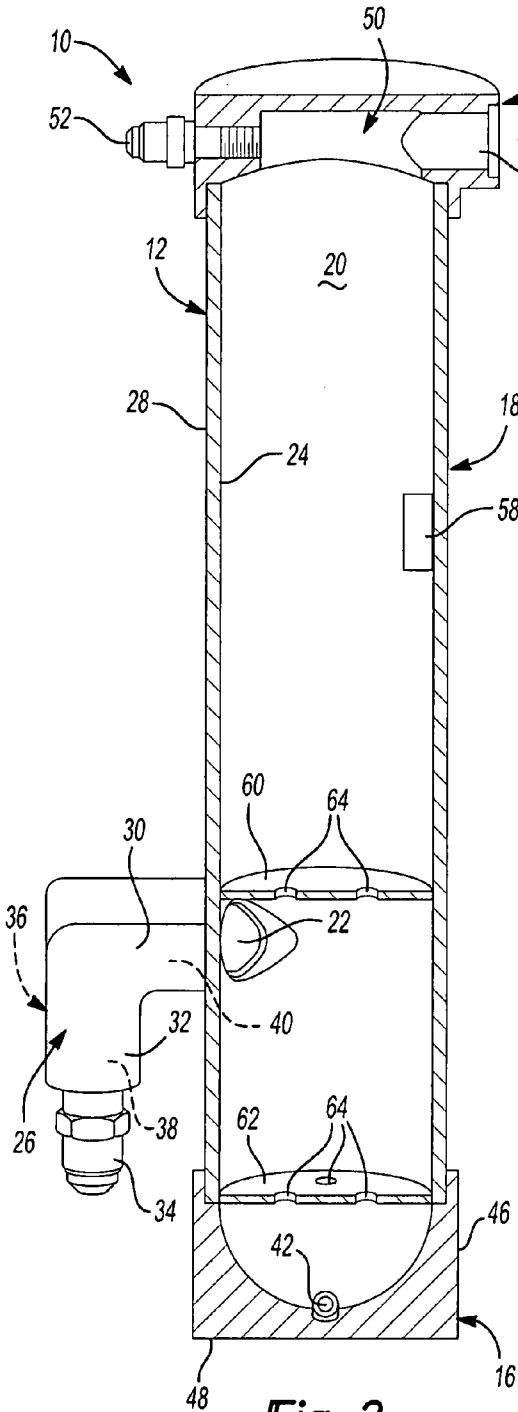


Fig-2

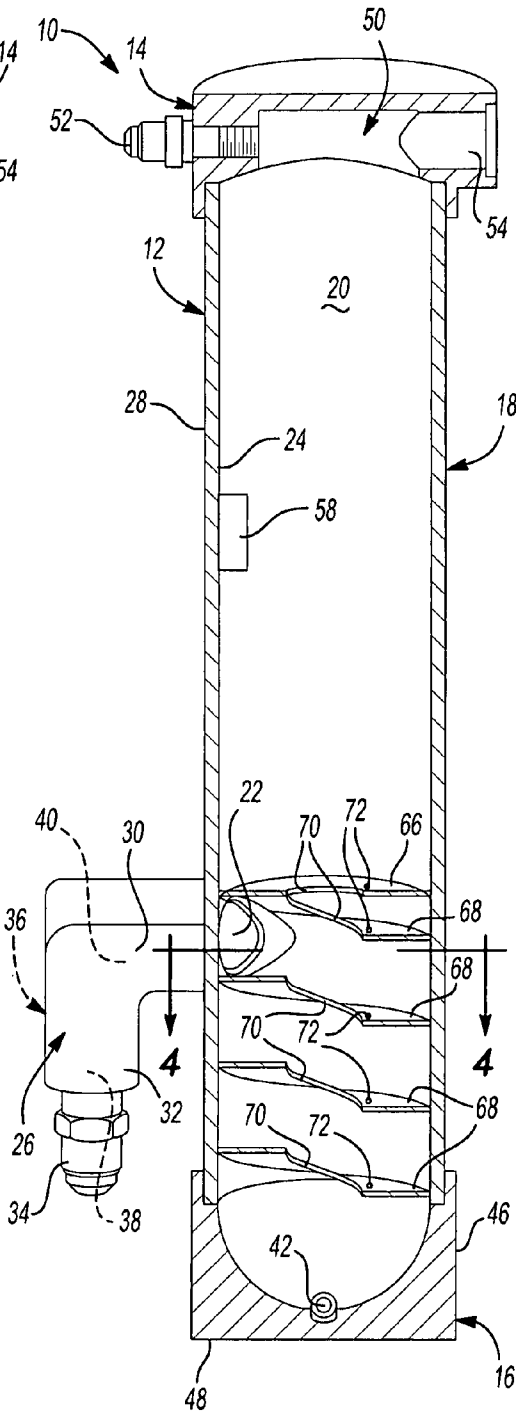
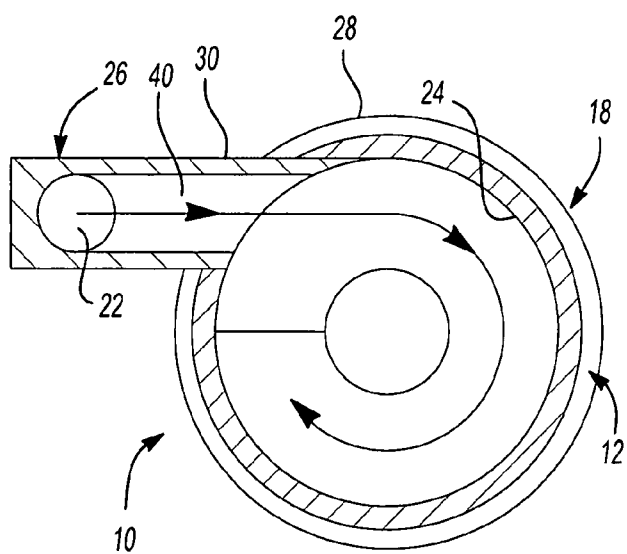
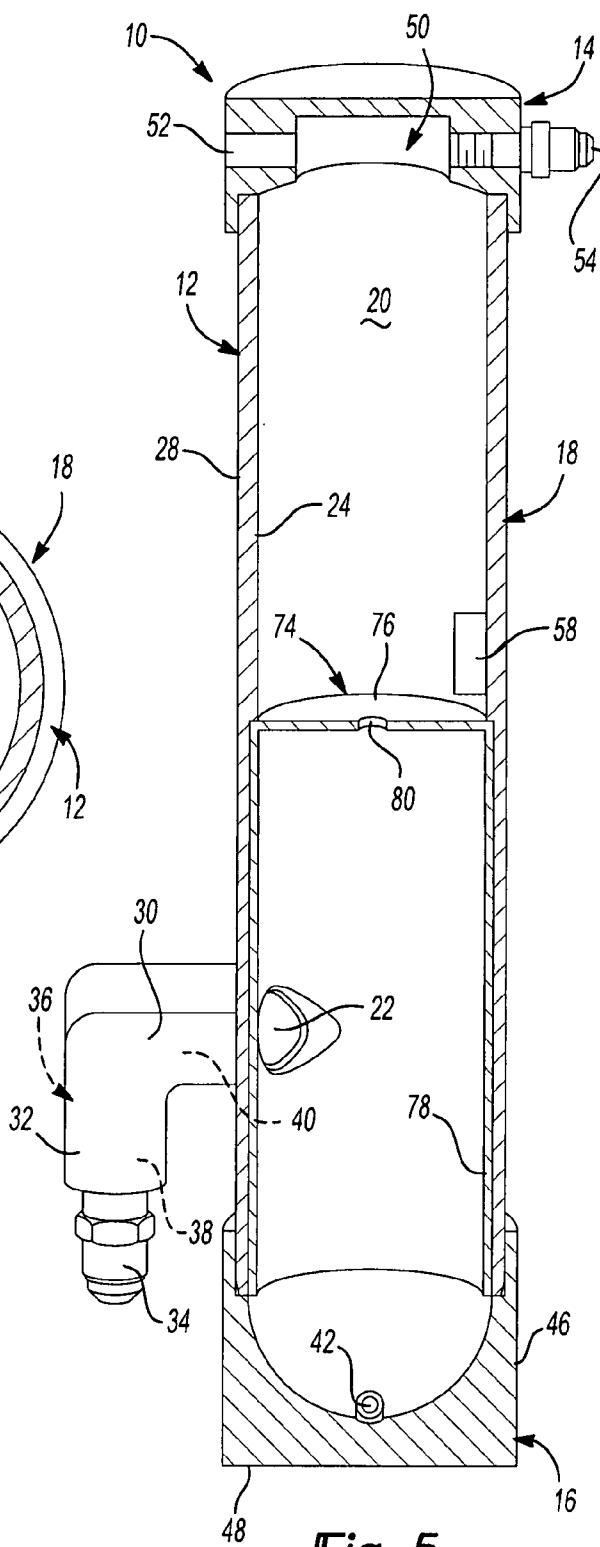


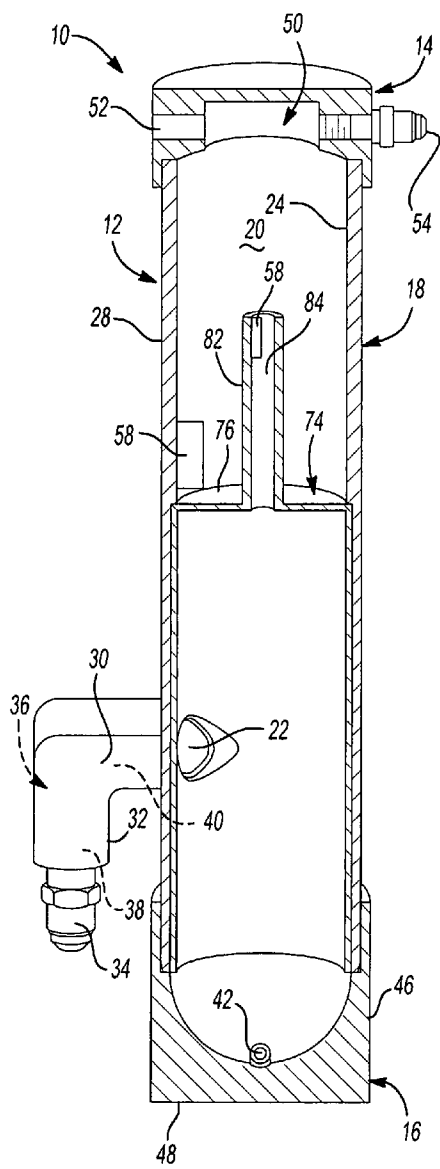
Fig-3



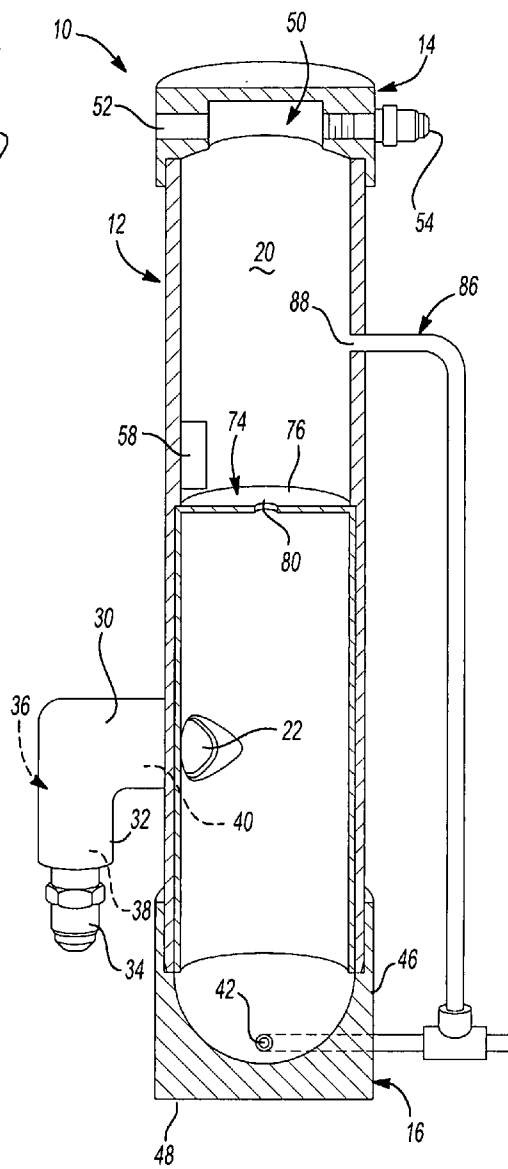
**Fig-4**



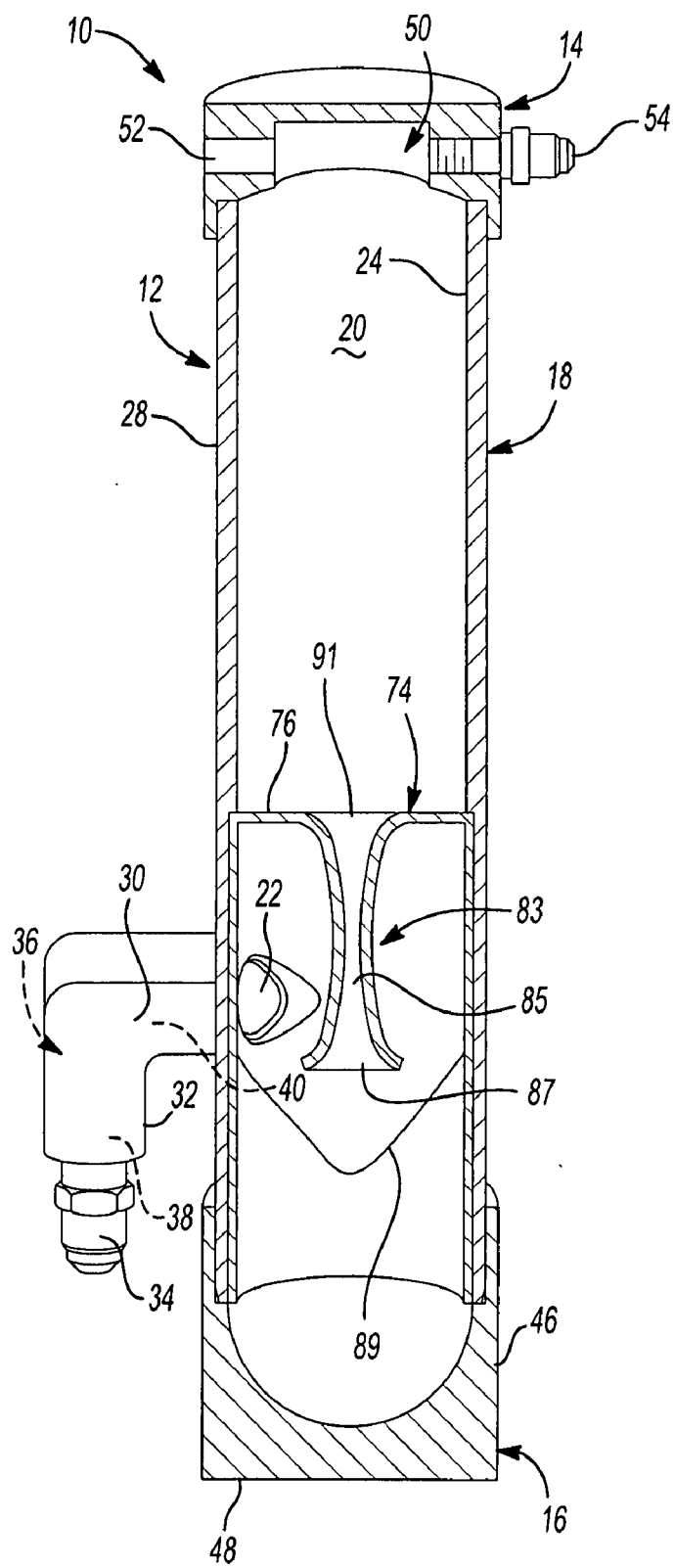
**Fig-5**



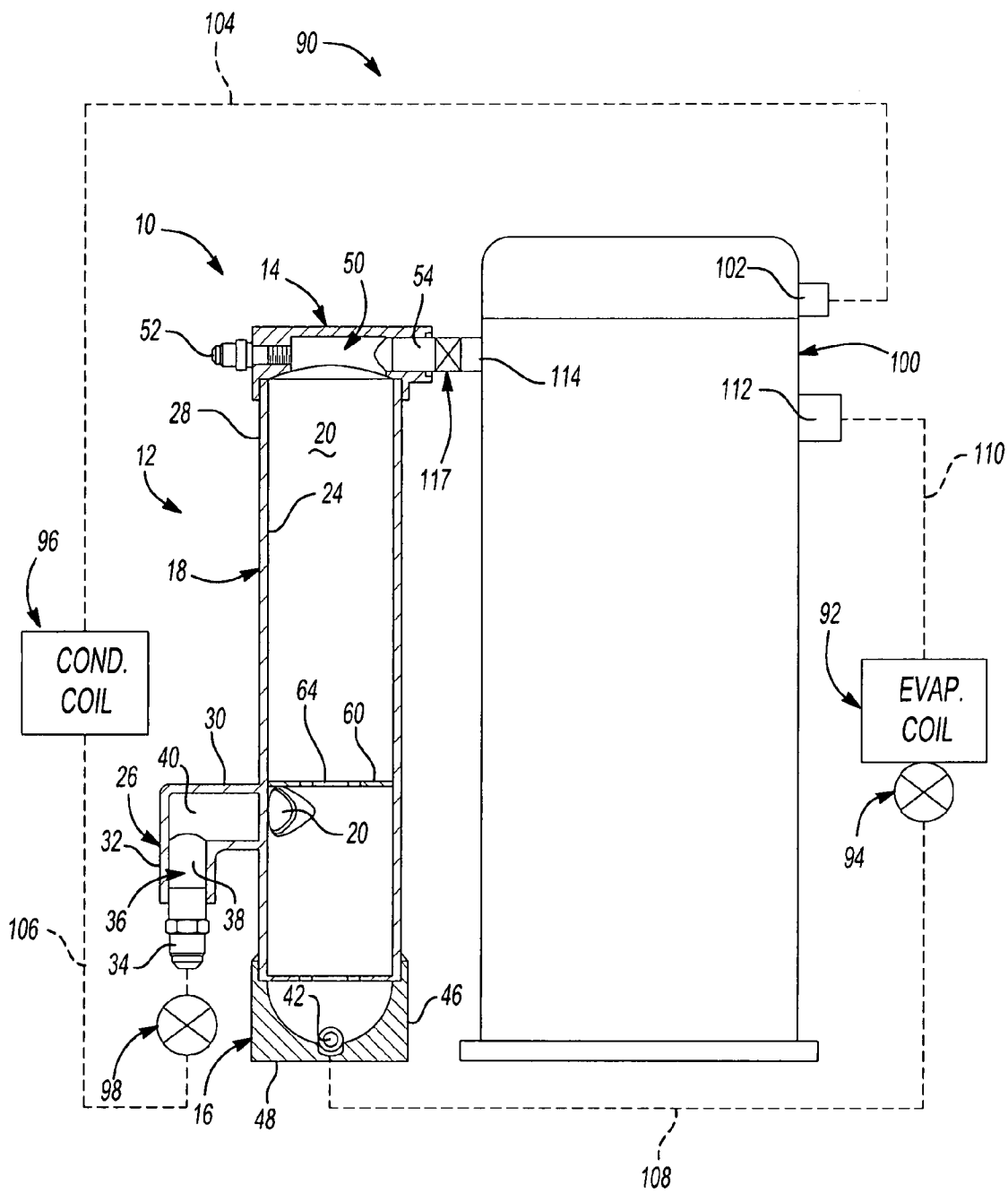
**Fig-6**



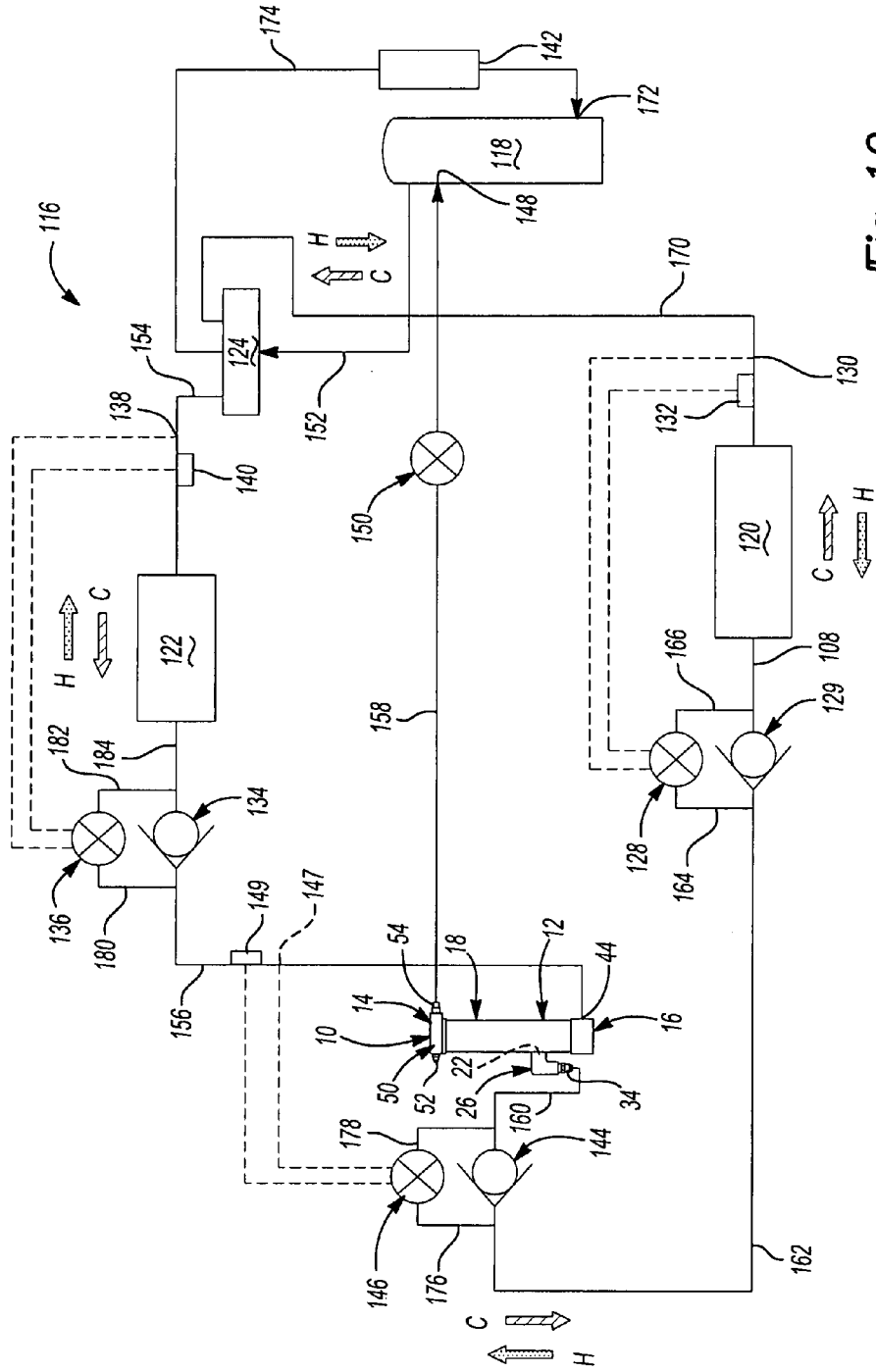
**Fig-7**



**Fig-8**

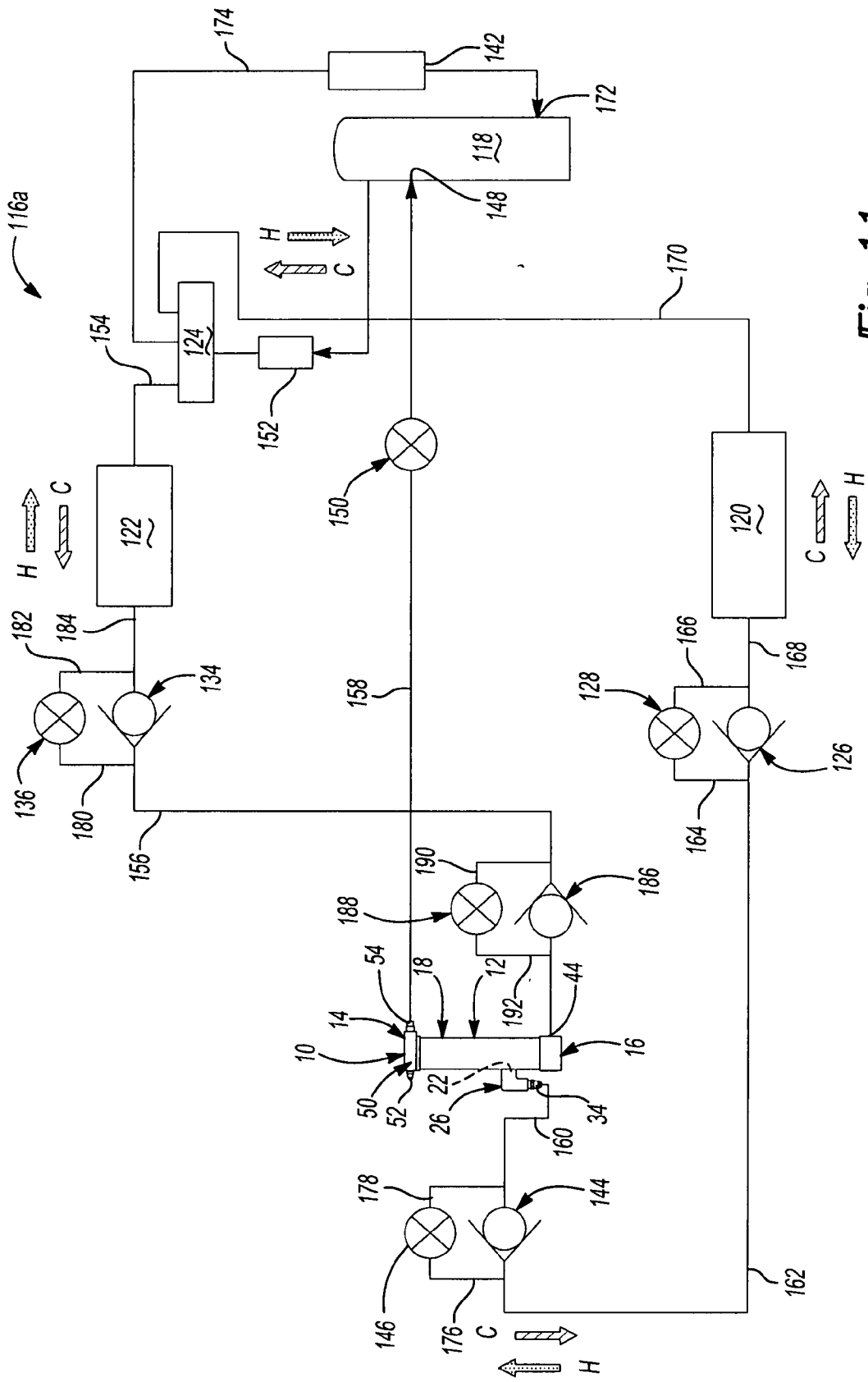


**Fig-9**

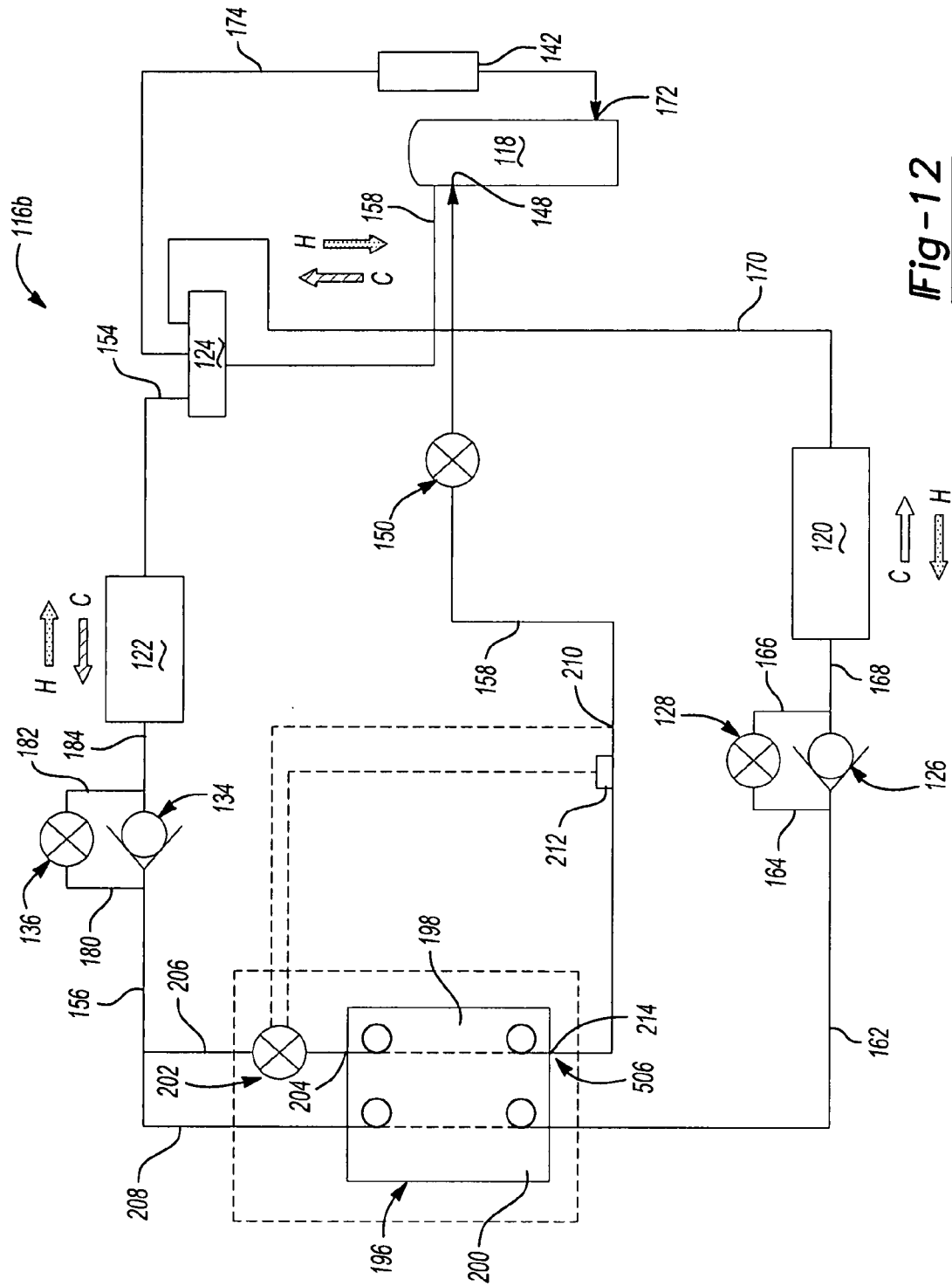


**Fig-10**

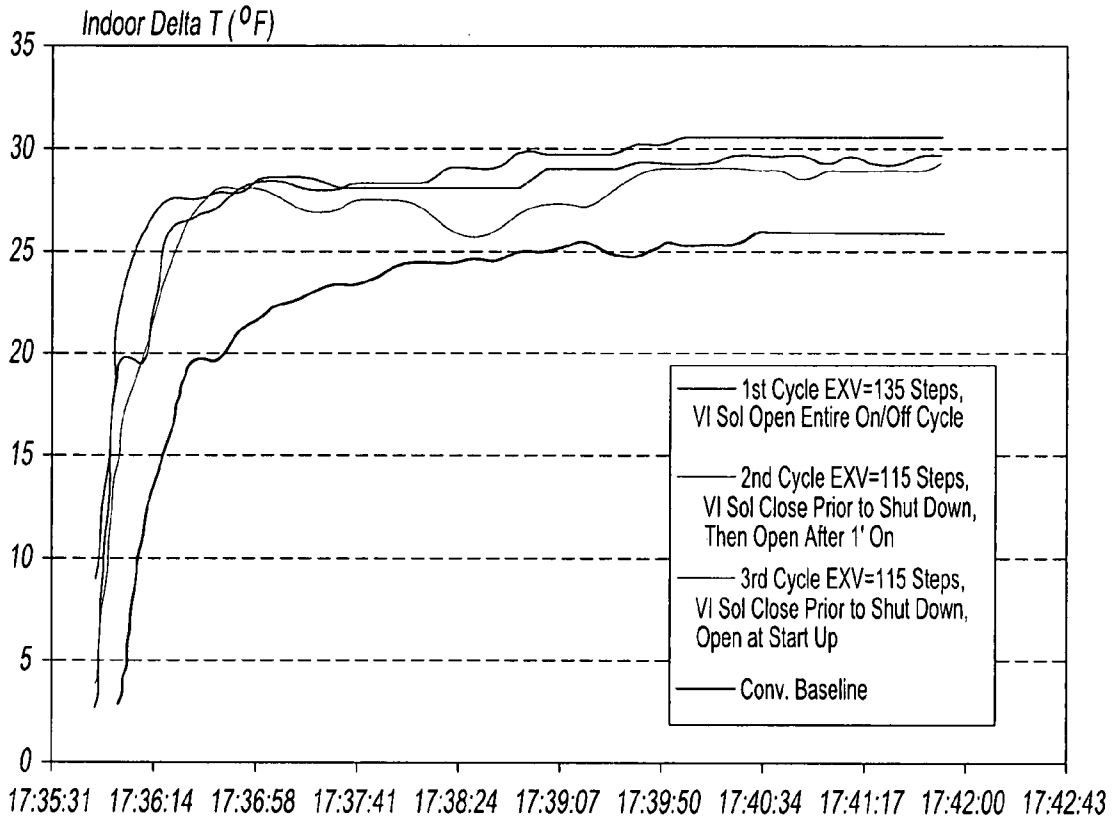
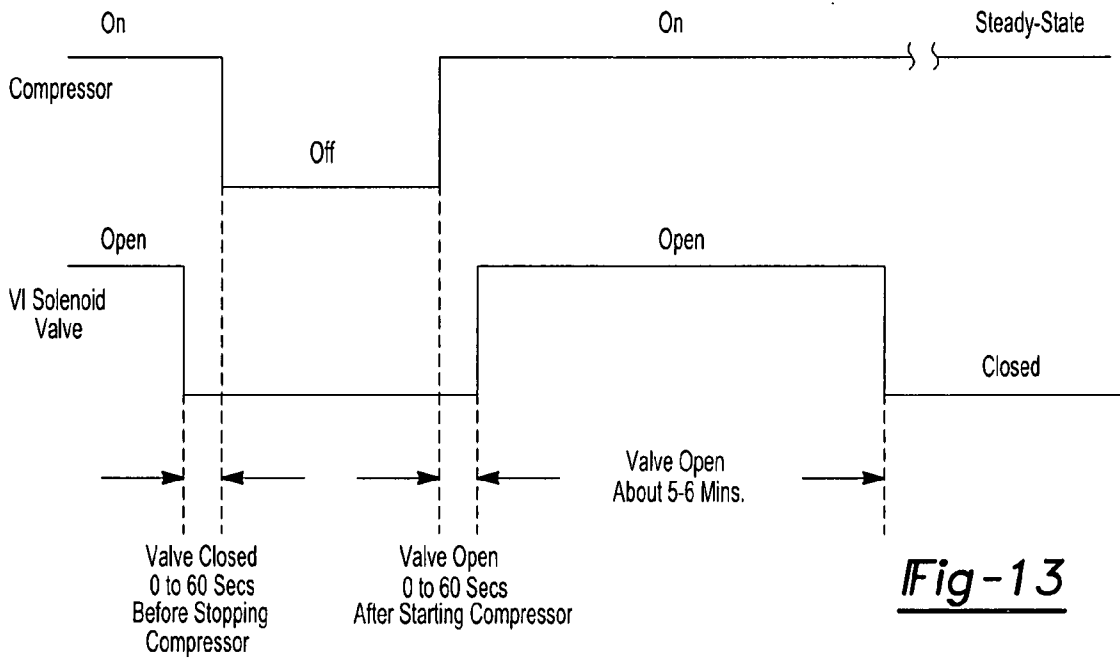




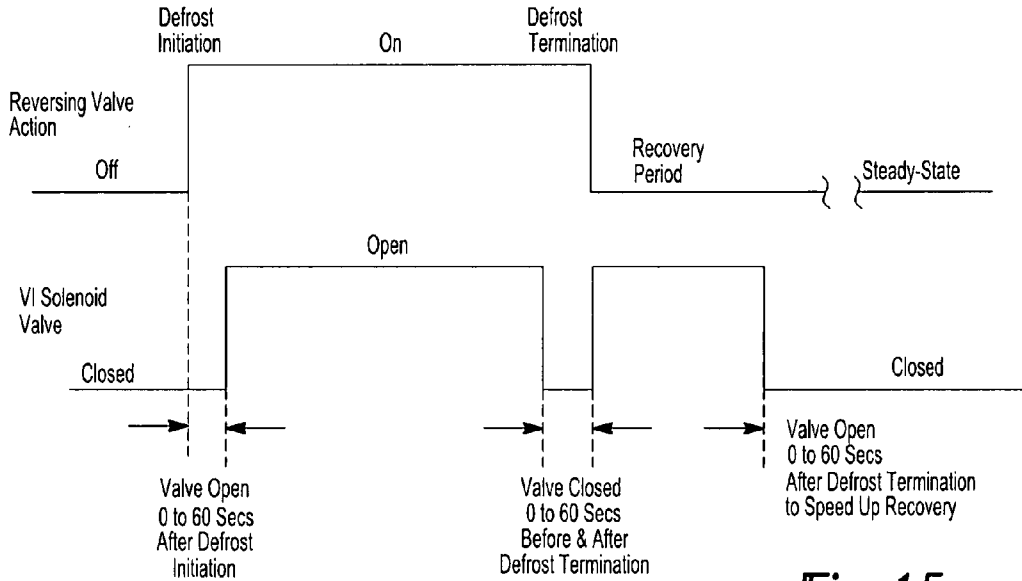
**Fig-11**



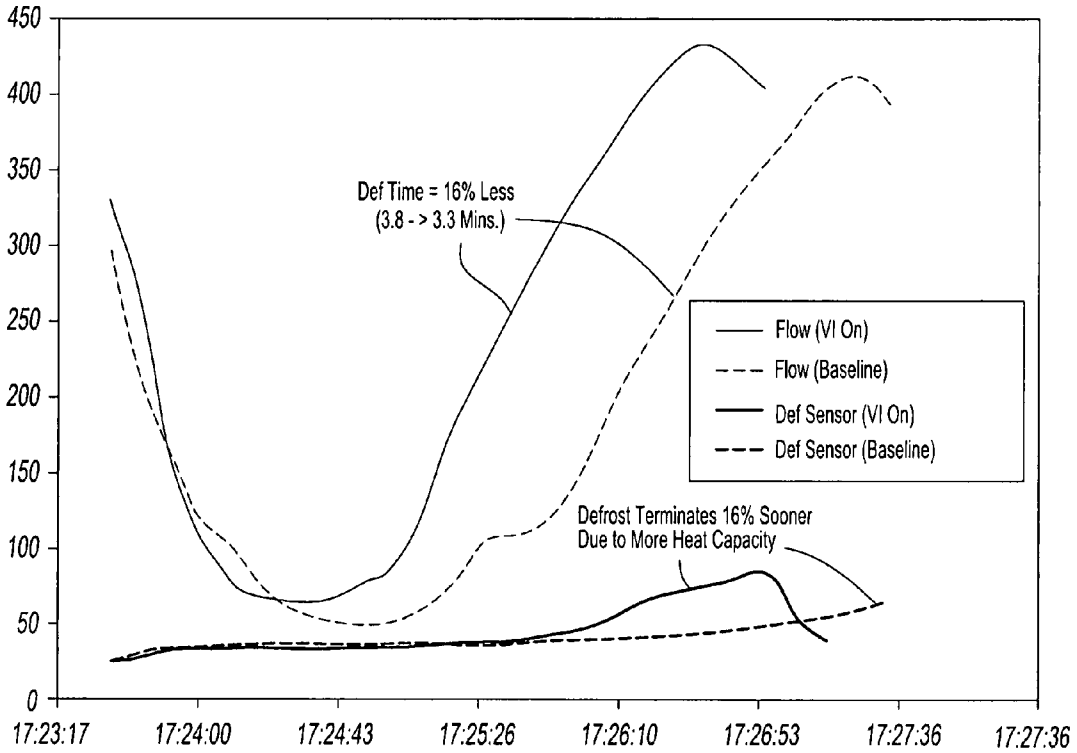
**Fig-12**



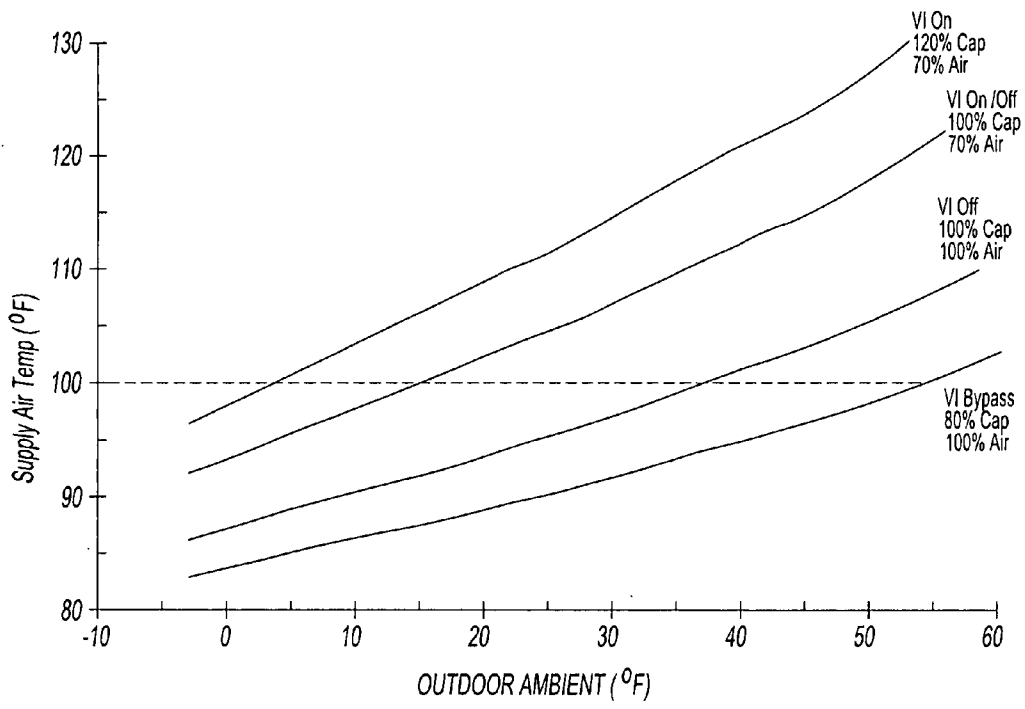
**Fig-14**



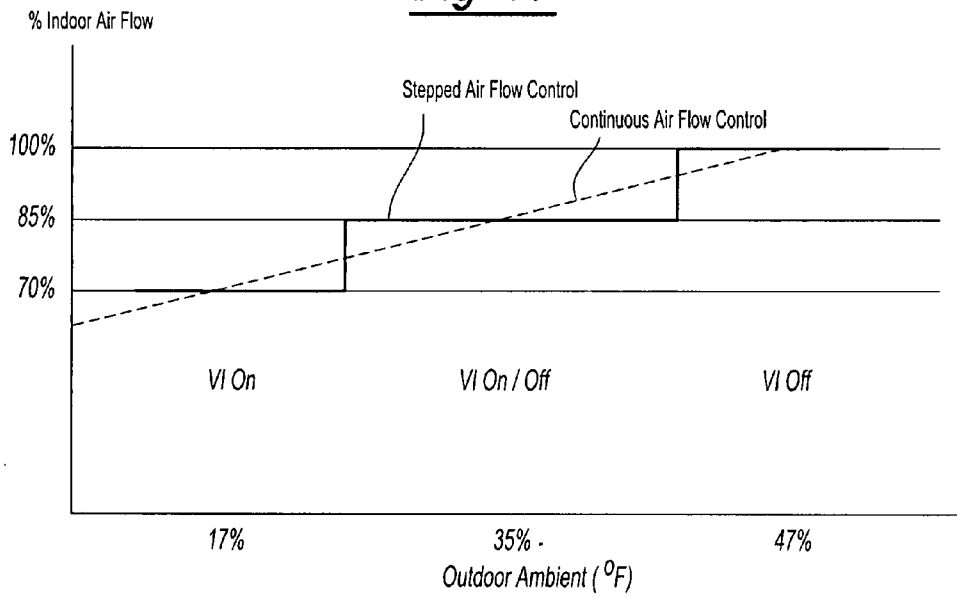
**Fig-15**



**Fig-16**



**Fig-17**



**Fig-18**

**FLASH TANK DESIGN AND CONTROL FOR HEAT PUMPS**

**CROSS-REFERENCE TO RELATED APPLICATIONS**

[0001] This application claims the benefit of U.S. Provisional Application No. 60/784,145, filed on Mar. 20, 2006. The disclosure of the above application is incorporated herein by reference.

**FIELD**

[0002] The present disclosure relates to vapor injection systems and more particularly to an improved flash tank and control scheme for a vapor injection system.

**BACKGROUND**

[0003] Scroll machines include an orbiting scroll member intermeshed with a non-orbiting scroll member to define a series of compression chambers. Rotation of the orbiting scroll member relative to the non-orbiting scroll member causes the compression chambers to progressively decrease in size and cause a fluid disposed within each chamber to be compressed.

[0004] During operation, the orbiting scroll member orbits relative to the non-orbiting scroll member through rotation of a drive shaft, which is typically driven by an electric motor. Because the drive shaft is driven by an electric motor, energy is consumed through rotation of the orbiting scroll member. Energy consumption increases with increasing discharge pressure as the scroll machine is required to perform more work to achieve higher pressures. Therefore, if the incoming vapor (i.e., vapor introduced at a suction side of the scroll machine) is at an elevated pressure, less energy is required to fully compress the vapor to the desired discharge pressure.

[0005] Vapor injection systems may be used with scroll machines to improve efficiency by supplying intermediate-pressure vapor to the scroll machine. Because intermediate-pressure vapor is at a somewhat higher pressure than suction pressure and at a somewhat lower pressure than discharge pressure, the work required by the scroll machine in producing vapor at discharge pressure is reduced.

[0006] Vapor injection systems typically extract vapor at an intermediate pressure from an external device commonly referred to as an economizer such as a flash tank or a heat plate exchanger for injection into a compression chamber of a scroll machine. The flash tank or plate heat exchanger is typically coupled to the scroll machine and a pair of heat exchangers for use in improving system capacity and efficiency. The pair of heat exchangers each serve as a condenser and an evaporator of the system depending on the mode (i.e., cooling or heating).

[0007] In operation, the flash tank receives liquid refrigerant from the condenser for conversion into intermediate-pressure vapor and sub-cooled liquid refrigerant. Because the flash tank is held at a lower pressure relative to the inlet liquid refrigerant, some of the liquid refrigerant vaporizes, elevating the pressure of the vaporized refrigerant within the tank. The remaining liquid refrigerant in the flash tank loses heat and becomes sub-cooled for use by the evaporator.

Therefore, conventional flash tanks contain both vaporized refrigerant and sub-cooled liquid refrigerant.

[0008] The vaporized refrigerant from the flash tank is distributed to an intermediate pressure input port of the scroll machine, whereby the vaporized refrigerant is at a substantially higher pressure than vaporized refrigerant leaving the evaporator, but at a lower pressure than an exit stream of refrigerant leaving the scroll machine. The pressurized refrigerant from the flash tank allows the scroll machine to compress this pressurized refrigerant to its normal output pressure while passing it through only a portion of the scroll machine.

[0009] The sub-cooled liquid is discharged from the flash tank and is sent to one of the heat exchangers depending on the desired mode (i.e., heating or cooling). Because the liquid is in a sub-cooled state, more heat can be absorbed from the surroundings by the heat exchanger, improving the overall heating or cooling performance of the system.

[0010] The flow of pressurized refrigerant from the flash tank to the scroll machine is regulated to ensure that only vaporized refrigerant or a minimum amount of liquid is received by the scroll machine. Similarly, flow of sub-cooled liquid refrigerant from the flash tank to the heat exchanger is regulated to inhibit flow of vaporized refrigerant from the flash tank to the evaporator. Conventional flash tanks regulate the flow of liquid refrigerant into the flash tank at an inlet of the tank to control the amount of vaporized refrigerant supplied to the scroll machine and sub-cooled liquid refrigerant supplied to the evaporator during one or both of a cooling mode and a heating mode.

**SUMMARY**

[0011] A flash tank for a heat pump operable in a heating mode and a cooling mode is provided and includes a shell having a middle portion disposed between a top portion and a bottom portion, with the top portion, bottom portion, and middle portion cooperating to define an inner volume of the shell. A first port is in fluid communication with the inner volume and functions as an inlet in the heating mode and as an outlet in the cooling mode. A second port is in fluid communication with the inner volume and functions as an inlet in the cooling mode and as an outlet in the heating mode.

[0012] In one aspect, the flash tank is incorporated into a heat pump system of the type which re-circulates refrigerant through a fluid circuit between a first heat exchanger acting as a condenser and a second heat exchanger acting as an evaporator including a compressor coupled to the fluid circuit. The flash tank is fluidly coupled to the first and second heat exchangers and to a vapor injection port of the compressor. The flash tank functions as a receiver in a cooling mode of the heat pump system and functions as a flash tank in a heating mode of the heat pump system.

[0013] Further areas of applicability will become apparent from the description provided herein. It should be understood that the description and specific examples are intended for purposes of illustration only and are not intended to limit the scope of the present disclosure.

**DRAWINGS**

[0014] The drawings described herein are for illustration purposes only and are not intended to limit the scope of the present disclosure in any way.

[0015] FIG. 1 is a perspective view of a flash tank in accordance with the principles of the present teachings;

[0016] FIG. 2 is a cross-sectional view of a flash tank in accordance with the principles of the present teachings incorporating a baffle arrangement;

[0017] FIG. 3 is a cross-sectional view of a flash tank in accordance with the principles of the present teachings incorporating a baffle arrangement;

[0018] FIG. 4 is a cross-sectional view of the flash tank of FIG. 3 taken along the line 4-4;

[0019] FIG. 5 is a cross-sectional view of a flash tank in accordance with the principles of the present teachings incorporating an internal shell including a top disk having an aperture formed therethrough to allow fluid communication between a top portion of the flash tank and a bottom portion of the flash tank;

[0020] FIG. 6 is a cross-sectional view of the flash tank in accordance with the principles of the present teachings incorporating an internal shell including a top disk having a tube formed thereon to allow fluid communication between a top portion of the flash tank and a bottom portion of the flash tank;

[0021] FIG. 7 is a cross-sectional view of a flash tank in accordance with the principles of the present teachings incorporating an internal shell having a top disk portion including an aperture formed therethrough and a recirculation tube in communication with the top portion of the tank to maintain a liquid level within the flash tank at a predetermined level;

[0022] FIG. 8 is a cross-sectional view of the flash tank in accordance with the principles of the present teachings incorporating an internal shell including a top disk having a tube formed thereon to allow fluid communication between a top portion of the flash tank and a bottom portion of the flash tank;

[0023] FIG. 9 is a schematic view of a cooling or refrigeration system including a flash tank fluidly coupled to a compressor;

[0024] FIG. 10 is a schematic view of a heat pump system incorporating a flash tank;

[0025] FIG. 11 is a schematic view of a heat pump system incorporating a flash tank;

[0026] FIG. 12 is a schematic view of a heat pump system incorporating a plate heat exchanger;

[0027] FIG. 13 is a schematic diagram illustrating a control scheme for a vapor injection system;

[0028] FIG. 14 is a graphical representation of indoor temperature change achieved variations of the control scheme of FIG. 13;

[0029] FIG. 15 is a schematic diagram illustrating a defrost control scheme;

[0030] FIG. 16 is a graphical representation of flow rate through a heat exchanger achieved using the control scheme of FIG. 13;

[0031] FIG. 17 is a graphical representation of a supply air temperature versus outdoor ambient temperature; and

[0032] FIG. 18 is a graphical representation of percent indoor air flow versus outdoor ambient temperature.

#### DETAILED DESCRIPTION

[0033] The following description is merely exemplary in nature and is not intended to limit the present disclosure, application, or uses.

[0034] Vapor injection may be used in air conditioning, chiller, refrigeration, and heat pump systems to improve system capacity and efficiency. Such vapor injection systems may include a flash tank that receives liquid refrigerant and converts the liquid refrigerant into intermediate-pressure vapor and sub-cooled liquid refrigerant. The intermediate-pressure vapor is supplied to a compressor while the sub-cooled liquid refrigerant is supplied to a heat exchanger. Supplying intermediate-pressure vapor to a compressor and sub-cooled liquid refrigerant to a heat exchanger improves the overall system capacity and efficiency of an air conditioning, chiller, refrigeration, and/or heat pump system.

[0035] Vapor injection may be used in heat pump systems, which are capable of providing both heating and cooling to commercial and residential buildings, to improve one or both of heating and cooling capacity and efficiency. For the same reasons, flash tanks may be used in chiller applications to provide a cooling effect for water, in refrigeration systems to cool an interior space of a display case or refrigerator, and an air conditioning system to effect the temperature of a room or building. While heat pump systems may include a cooling cycle and a heating cycle, chiller, refrigeration and air conditioning systems often only include a cooling cycle, however, heat pump chillers, which provide heating and cooling cycle, are the norm in some parts of the world. Each system may use a refrigerant to generate the desired cooling or heating effect through a refrigeration cycle.

[0036] For air conditioning applications, the refrigeration cycle is used to lower the temperature of a space to be cooled, typically a room or building. For this application, a fan or blower is typically used to force ambient air into more rapid contact with an evaporator to increase heat transfer and cool the surroundings.

[0037] For chiller applications, the refrigeration cycle cools or chills a stream of water. Heat pump chillers use the refrigeration cycle to heat a stream of water when operating in a heat mode. Rather than using a fan or blower, the refrigerant remains on one side of the heat exchanger while circulating water or brine provides the heat source for evaporation. Heat pump chillers often use ambient air as the heat source for evaporation during heat mode but may also use other sources such as ground water or a heat exchanger that absorbs heat from the earth. Thus, the heat exchanger cools or heats the water passing therethrough as heat is transferred from the water into the refrigerant on cool mode and from the refrigerant into the water on heat mode.

[0038] In a refrigeration system, such as a refrigerator or refrigerated display case, the heat exchanger cools an interior space of the device and a condenser rejects the adsorbed heat. A fan or blower is often used to force the air in the interior space of the device into more rapid contact with the evaporator to increase heat transfer and cooling interior space.

[0039] In a heat pump system, the refrigeration cycle is used to both heat and cool. The heat pump system may

include an indoor unit and an outdoor unit, with the indoor unit being capable of either heating or cooling a room or an interior space of a commercial or residential building. The heat pump may also be of a monobloc construction with the "outdoor" and "indoor" parts combined in one frame.

[0040] While each of the foregoing systems has unique features, vapor injection may be used to improve system capacity and efficiency. Specifically, in each system, a flash tank receiving a stream of liquid refrigerant from a heat exchanger and converting a portion of the liquid refrigerant into vapor, may be used to reduce the amount of work required by the compressor in producing vapor at a desired discharged pressure.

[0041] Because the vapor received by the compressor from the flash tank is at an intermediate pressure, which is somewhat higher than suction pressure and somewhat lower than discharge pressure, the amount of work required by the compressor to compress this intermediate-pressure vapor to the desired discharge pressure is reduced as the intermediate-pressure vapor is only required to pass through a portion of the compressor.

[0042] The sub-cooled liquid refrigerant created as a by product of the intermediate-pressure vapor increases the overall capacity and efficiency of the system by increasing the efficiency and capacity of an evaporator and a condenser associated with the system. Because the liquid discharged from the flash tank is sub-cooled, when the liquid is supplied to the evaporator, more heat can be adsorbed from the surroundings, thereby increasing the overall performance of the pair of heat exchangers (i.e., condenser and evaporator) in a heating or cooling mode.

[0043] With reference to FIGS. 1-8, a flash tank 10 is provided for use with any of the aforementioned systems. The flash tank 10 includes a shell 12 having a top portion 14, a bottom portion 16, and a middle portion 18 extending generally between the top portion 14 and the bottom portion 16. The top portion 14, bottom portion 16, and middle portion 18 cooperate to define an inner volume 20 of the shell 12. The shell preferably includes a height-to-diameter ratio of about four to six to enhance liquid separation by gravity. In one exemplary embodiment, the shell 12 may include a height of 12 inches and a diameter of 2.5 inches, yielding a height-to-diameter aspect ratio of about five. Such a configuration yields an inner volume 20 of about 50 cubic inches, which is effectively sized for a three-ton heat pump based on about 20 percent vapor injection.

[0044] The shell 12 includes a first port 22 formed through the middle portion 18 and disposed a distance away from the bottom 16 of the shell 12 approximately equal to one-third of a total height of the shell 12. The first port 22 is in fluid communication with the inner volume 20 and is positioned tangentially to an inner surface 24 of the middle portion 18 such that entering fluid at the first port 22 contacts and flows about the inner surface 24, as best shown in FIG. 4.

[0045] An L-shaped elbow 26 is attached to an outer surface 28 of the middle portion 18 and is fluidly coupled to the first port 22. The L-shaped elbow 26 includes a first portion 30 attached to the outer surface 28 of the middle portion 18 and adjacent to the first port 22. The first portion 30 extends from the outer surface 28 such that the first portion 30 is generally perpendicular to the middle portion

18. A second portion 32 of the L-shaped elbow 26 is fluidly coupled to the first portion 30 and extends from the first portion 30 at approximately a ninety degree angle such that the second portion 32 is substantially perpendicular to the first portion 30. Because the second portion 32 is generally perpendicular to the first portion 30, the second portion 32 is spaced apart from, and generally parallel to, the middle portion 18. The second portion 32 includes a fitting 34 disposed at an end of the second portion 32 generally opposite from a connection between the first and second portions 30, 32.

[0046] Cooperation between the first portion 30, second portion 32, and fitting 34 provides a fluid passage 36 in communication with the inner volume 20 of the shell 12 via first port 22. The fluid passage 36 includes a first chamber 38 fluidly coupled to the fitting 34 and fluidly coupled to a second chamber 40 of the first portion 30. The second chamber 40 is fluidly coupled to the first port 22 of the shell 12 and includes a greater volume than the first chamber 38. The greater volume of the second chamber 40 allows the second chamber 40 to act as an expansion volume to reduce turbulence associated with a high-velocity expanded refrigerant incoming fluid prior to the fluid reaching the inner volume 20 of the shell 12. The second chamber 40 may also or alternatively include a lesser volume than the first chamber 38, but may include a greater diameter when compared to the first chamber 38 to reduce a velocity of an incoming fluid prior to the fluid reaching the inner volume 20 of the shell 12.

[0047] The flash tank 10 further includes a second port 42 disposed generally at the bottom portion 16 of the shell 12. The second port 42 is fluidly coupled to the inner volume 20 of the shell 12 and to a fitting 44. While the fitting 44 is shown generally perpendicular to an outer surface 46 of the bottom portion 16, the fitting 44 may alternatively extend from a bottom surface 48 of the bottom portion 16. Positioning of the fitting 44 on either the side surface 46 or bottom surface 48 of the bottom portion 16 is largely dependent on the configuration of the flash tank 10 and the system to which the flash tank 10 may be coupled.

[0048] The flash tank 10 further includes a vapor injection arrangement 50 disposed generally within the top portion 14 of the shell 12. The vapor injection arrangement 50 includes a pressure tap 52 and an outlet 54. The pressure tap 52 provides the flash tank 10 with the ability to measure the pressure of the flash tank (i.e., injection pressure) for the purpose of controlling a liquid level within the flash tank. The outlet 54 is fluidly coupled to the inner volume 20 of the shell 12 for discharging intermediate-pressure vapor stored within an upper portion of the inner volume 20.

[0049] In operation, liquid is received generally at the L-shaped elbow 26 and travels along the fluid passage 36 prior to reaching the first port 22. A velocity of the incoming fluid is reduced due to interaction between the fluid and the second chamber 40 of the L-shaped fitting 26. Specifically, when the incoming fluid travels through the first chamber 38 of the L-shaped elbow 26, the fluid makes a substantially ninety degree turn, encountering the second chamber 40. Because the second chamber 40 includes a larger volume and/or larger diameter than the first chamber 38, the entering fluid loses velocity within the second chamber 40, thereby reducing the turbulence associated with the fluid flow.



[0050] The fluid encounters the first port 22 upon exiting the second chamber 40 of the L-shaped elbow 26. Because the first port 22 is positioned tangentially relative to the inner surface 24 of the middle portion 18, the flow is caused to travel along the inner surface 24, thereby reducing any remaining turbulence associated with the incoming fluid flow. Once the flow enters the inner volume 20 of the shell 12, the fluid separates by gravity into a sub-cooled liquid and an intermediate-pressure vapor as the flash tank 10 is held at a lower pressure relative to the inlet liquid. The sub-cooled liquid collects generally at the bottom portion 16 of the shell 12 while the intermediate-pressure vapor collects near a top portion 14 of the shell 12.

[0051] In one exemplary embodiment, the level of sub-cooled liquid disposed with the inner volume 20 of the shell 12, is maintained at a height substantially equal to two-thirds of a total tank height such that the upper one-third of the shell 12 contains intermediate-pressure vapor. Maintaining the sub-cooled liquid level within the interior volume 20 of the shell 12 may be accomplished through use of either a sight glass 56 or a liquid-level sensor 58 or by regulating the flash tank flow controls using a parameter such as the injection pressure or the compressor discharge temperature. If a sight glass 56 is used to monitor the liquid level of the sub-cooled liquid within the shell 12, the sight glass 56 is preferably disposed near a desired level of liquid in the shell 12. As described above, one such preferred liquid level is approximately equal to two-thirds of a total height of the shell 12. Therefore, placing the sight glass 56 at approximately two-thirds of the total tank height of the shell 12 allows for determination of a level of sub-cooled liquid disposed within the inner volume 20.

[0052] If a liquid-level sensor 58 is used either in conjunction with, or in place of, the sight glass 56, the liquid-level sensor 58 may be positioned at the desired liquid level with the inner volume 20 of the shell 12 to allow for determination of the liquid level within the inner volume 20. Additional liquid-level sensors 58 may also be used within the inner volume 20 of the shell 12 to determine an exact sub-cooled liquid level within the interior volume to provide specific liquid level data if the liquid within the inner volume 20 exceeds the desired liquid level or drops below a low-limit threshold.

[0053] As described above, the incoming fluid entering the flash tank 10 is typically turbulent. The turbulence associated with the incoming fluid reduces the ability of the flash tank 10 to adequately separate into the sub-cooled liquid and the intermediate-pressure vapor. Therefore, reducing the turbulence of the incoming fluid improves the ability of the flash tank 10 to separate the fluid into sub-cooled liquid and intermediate-pressure vapor. While the expansion volume of the second chamber 40 and the positioning of the first port 22 relative to the inner surface 24 of the middle portion 18 (i.e., tangential to the inner surface 24) reduces the turbulence associated with the incoming fluid, additional measures may be taken to further control the incoming fluid.

[0054] With particular reference to FIG. 2, the flash tank 10 is shown to include an upper baffle 60 and a lower baffle 62. The upper baffle 60 is positioned generally above the first port 22 and includes a series of apertures 64 to allow communication between the bottom portion 16 of the shell 12 and the top portion 14 of the shell 12. The lower baffle

62 is located generally adjacent to the bottom portion 16 of the shell 12 and similarly includes a series of apertures 64.

[0055] The apertures 64 of the lower baffle 62 allow communication between the first port 22 and the second port 42 to allow any sub-cooled liquid disposed generally above the lower baffle 62 to travel through the various apertures 64 of the lower baffle 62 and exit the shell 12 at the second port 42. The upper and lower baffles 60, 62 cooperate to confine the incoming flow generally between the upper and lower baffles 60, 62. Therefore, any turbulence associated with the incoming liquid is generally confined and does not disturb the vapor near the top portion 14 of the shell 12.

[0056] For example, if the top portion 14 of the shell 12 includes intermediate-pressure vapor, the upper baffle 60 prevents fluid entering the shell 12 at the first port 22 from sloshing sub-cooled liquid above the upper baffle 60 and therefore prevents mixture of the sub-cooled liquid with the intermediate-pressure vapor. Without the upper baffle 60, the incoming fluid may cause the sub-cooled liquid disposed within the inner volume 20 of the shell 12 to mix with the intermediate-pressure vapor and therefore may cause the vapor injection arrangement 50 to supply intermediate-pressure vapor mixed with sub-cooled liquid and incoming liquid at the outlet 54 of the vapor injection arrangement 50. Such a mixture is desirable in a minimal quantity (i.e., approximately 5% liquid and 95% vapor), but in excess can adversely affect the durability of a compressor to which the vapor injection arrangement 50 may be coupled. Therefore, cooperation between the upper baffle 60 and lower baffle 62 improves the overall function of the flash tank 10 by allowing the flash tank 10 to more efficiently and more effectively separate the incoming fluid to sub-cooled liquid and intermediate-pressure vapor.

[0057] With particular reference to FIG. 3, the flash tank 10 is shown to include an upper baffle 66 and a series of angled baffles 68. The upper baffle 66 is positioned within the inner volume 20 of the shell 12 such that the upper baffle 66 is generally perpendicular to the inner surface 24 of the middle portion 18. The upper baffle 66 may include a central aperture 70 and/or a series of smaller apertures 72 to allow communication between the bottom portion 16 of the shell 12 and the top portion 14 of the shell 12. The angled baffles 68 extend downward from the upper baffle 66 and are positioned at an angle relative to the upper baffle 66. Each of the angled baffles 68 include the central aperture 70 extending therethrough and may additionally or alternatively include a series of smaller apertures 72. Again, as with the upper baffle 66, the central aperture 70 and/or smaller apertures 72 provide fluid communication through the angled baffles 68 such that fluid communication between the bottom portion 16 of the shell 12 and the top portion 14 of the shell 12 is achieved.

[0058] As previously described, turbulence associated with incoming fluid can adversely affect the performance of the flash tank 10 in separating the incoming fluid into sub-cooled liquid and intermediate-pressure vapor. The upper baffle 66 and angled baffles 68 cooperate to reduce this turbulence associated with the incoming fluid. Specifically, when the fluid is introduced at the first port 22 of the shell 12, the fluid engages the inner surface 24 of the middle portion 18 due to the tangential relationship between the first port 22 and the inner surface 24, as previously discussed.

The tangential relationship between the first port 22 and the inner surface 24 causes the incoming fluid to engage the inner surface 24 and travel around the inner surface 24, as best shown in FIG. 4. Cooperation between the upper baffle 66 and the angled baffles 68 further enhances the flow of the incoming fluid about the inner surface 24 of the middle portion 18 and away from the upper baffle 66. apertures 72 to allow communication between the bottom portion 16 of the shell 12 and the top portion 14 of the shell 12. The angled baffles 68 extend downward from the upper baffle 66 and are positioned at an angle relative to the upper baffle 66. Each of the angled baffles 68 include the central aperture 70 extending therethrough and may additionally or alternatively include a series of smaller apertures 72. Again, as with the upper baffle 66, the central aperture 70 and/or smaller apertures 72 provide fluid communication through the angled baffles 68 such that fluid communication between the bottom portion 16 of the shell 12 and the top portion 14 of the shell 12 is achieved.

[0059] As previously described, turbulence associated with incoming fluid can adversely affect the performance of the flash tank 10 in separating the incoming fluid into sub-cooled liquid and intermediate-pressure vapor. The upper baffle 66 and angled baffles 68 cooperate to reduce this turbulence associated with the incoming fluid. Specifically, when the fluid is introduced at the first port 22 of the shell 12, the fluid engages the inner surface 24 of the middle portion 18 due to the tangential relationship between the first port 22 and the inner surface 24, as previously discussed. The tangential relationship between the first port 22 and the inner surface 24 causes the incoming fluid to engage the inner surface 24 and travel around the inner surface 24, as best shown in FIG. 4. Cooperation between the upper baffle 66 and the angled baffles 68 further enhances the flow of the incoming fluid about the inner surface 24 of the middle portion 18 and away from the upper baffle 66. portion 18, to further improve the ability of the flash tank 10 to prevent the sub-cooled and entering liquid from mixing with the intermediate-pressure vapor.

[0060] With particular reference to FIG. 5, the inner shell 74 is shown to include a top disk 76 formed generally perpendicular to the middle portion 18 and a cylindrical body 78 extending from a bottom portion of the top disk 78 towards the bottom portion 16 of the shell 12. The top disk 76 may be in contact with the inner surface 24 of the middle portion 18 such that fluid communication between the bottom portion 16 of the shell 12 and the top portion 14 of the shell 12 is not permitted between the junction of the top disk 76 and the inner surface 24 of the middle portion 18. Rather, fluid communication between the bottom portion 16 and the top portion 14 is controlled through an aperture 80 formed in the top disk 76. The aperture 80 allows vapor, which is created from the entering fluid at the first port 22, to escape from an area generally below the top disk 76 and toward the top portion 14 of the shell 12. While the aperture 80 allows the intermediate-pressure vapor to escape through the top disk 76 toward the top portion 14 of the shell 12, the top disk 76 restricts incoming fluid at the first port 22 and sub-cooled liquid disposed within the bottom portion 16 from reaching the intermediate-pressure vapor stored at the top portion 14 of the shell 12.

[0061] The entering fluid at the first port 22 typically includes at least some turbulent flow, as previously dis-

ussed. Because the velocity and turbulence of the incoming fluid is not completely eliminated by the second chamber 40 of the L-shaped elbow 26 and the tangential relationship between the first port 22 and the inner surface 24 of the middle portion 18, the incoming fluid may mix with the sub-cooled liquid and may cause the incoming liquid to slosh within the inner volume 20 of the shell 12, thereby causing the fluid and/or the sub-cooled liquid already disposed within the inner volume 20 to slosh within the inner volume 20 and move generally toward the top portion 14 of the shell 12. Because the top disk 76 only includes the aperture 80, most of the fluid and/or sub-cooled liquid is restricted from reaching into the top portion 14 of the shell 12 and mixing with the intermediate-pressure vapor. Therefore, the top disk 76 effectively allows fluid communication between the bottom portion 16 of the shell 12 and the top portion 14 of the shell 12, while improving the ability of the flash tank 10 to maintain the intermediate-pressure vapor separate from the sub-cooled liquid and incoming fluid at the first port 22. Therefore, the top disk 76 improves the overall performance and efficiency of the flash tank 10 in separating the incoming fluid into intermediate-pressure vapor and sub-cooled liquid and in maintaining this separation.

[0062] While the top disk 76 has been described as including a single aperture 80, the top disk 76 may include a plurality of apertures formed therethrough to tailor the fluid flow between the bottom portion 16 of the shell 12 and the top portion 14 of the shell 12. The top disk 76 may be positioned at any height within the inner volume 20 of the shell 12, but is preferably positioned such that the top disk 76 is at the desired tank liquid level. In one exemplary embodiment, the desired sub-cooled liquid disposed within the inner volume 20 of the shell 12 is substantially equivalent to two-thirds of the total height of the shell 12. Therefore, the inner shell 74 may be positioned relative to the shell 12 such that the top disk 76 is located approximately at two-thirds of the total height of the shell 12.

[0063] With particular reference to FIG. 6, the flash tank 10 is shown including the inner shell 74 having a tube 82 extending from the top disk 76. The tube 82 allows fluid communication between the bottom portion 16 of the shell 12 and the top portion 14 of the shell 12, and includes a central bore 84 extending along the length of the tube 82. The tube 82 prevents the incoming fluid and/or sub-cooled liquid from reaching the top portion 14 of the shell 12 and mixing with the intermediate-pressure vapor stored within the top portion 14.

[0064] Because movement of the incoming fluid into the bottom portion 16 of the shell 12 is generally a turbulent flow such that the incoming fluid and/or sub-cooled liquid sloshes within the bottom portion 16, the incoming fluid and/or sub-cooled liquid generally rises and falls within the inner volume 20. Therefore, the fluid and/or sub-cooled liquid may rise at the localized aperture 80 formed in the top disk 76 and actually reach the top portion 14 of the shell 12.

[0065] The tube 82 allows the rising fluid and/or sub-cooled liquid to rise and extend into the bore 84 of the tube 82 without actually reaching and mixing with the intermediate-pressure vapor. Therefore, by providing the top disk 76 with the tube 82, mixing of incoming fluid at the first port 22 and/or sub-cooled liquid with the intermediate-pressure

vapor at the top portion 14 of the shell 12 is restricted to a desired mixing of "wet" injection (i.e., 5% liquid, as noted above).

[0066] With particular reference to FIG. 7, the flash tank 10 is shown to include the inner shell 74 incorporating aperture 80 and an overflow recirculation tube 86. As described above with respect to FIG. 5, the aperture 80 allows fluid communication between the bottom portion 16 of the shell 12 and the top portion 14 of the shell 12 while reducing the likelihood of mixing between incoming fluid and/or sub-cooled liquid with the intermediate-pressure vapor stored within the top portion 14. However, if the incoming liquid at the first port 22 has an excessive velocity or excess liquid refrigerant charge such that a turbulent flow is created within the inner volume 20 of the shell 12 is created, or the volume of incoming fluid and/or sub-cooled liquid exceeds a predetermined volume, the incoming fluid and/or sub-cooled liquid disposed within the inner volume 20 may rise within the inner volume 20 and encounter the aperture 80 such that incoming fluid and/or sub-cooled liquid passes through the aperture 80 and into the top portion 14 of the shell 12.

[0067] If the liquid and/or sub-cooled liquid passes through the aperture 80 and enters the top portion 14 of the shell 12, the liquid and/or sub-cooled liquid may mix with the intermediate-pressure vapor and be drawn from the inner volume 20 of the shell 12 by the vapor injection arrangement 50 at outlet 54, potentially causing damage to a compressor to which the flash tank 10 may be coupled.

[0068] The overflow recirculation tube 86 passes through the middle portion 18 of the shell 12 and is positioned generally above the aperture 80 of the top disk 76. The overflow recirculation tube 86 includes a fluid passage 88 that is fluidly coupled to the second portion 42 of the shell 12. If the incoming fluid and/or sub-cooled liquid flows through the aperture 80, passing through the top disk 76 of the inner shell 74, the fluid and/or sub-cooled liquid will be collected by the overflow recirculation tube 86 and mixed with the exiting sub-cooled liquid at the second port 42 via fluid passage 88 to prevent mixing of incoming fluid and/or sub-cooled liquid with intermediate-pressure vapor. Cooperation between the overflow recirculation tube 86 and the aperture 80 collects any fluid and/or sub-cooled liquid that may escape through the top disk 76 and redirects the fluid and/or sub-cooled liquid away from the top portion 14 of the shell 12 and, thus, away from the vapor injection arrangement 50.

[0069] While the inner shell 74 has been described as preventing incoming fluid and/or sub-cooled liquid from sloshing from the bottom portion 16 of the shell 12 to the top portion 14 of the shell 12, the inner shell 74 also improves the ability of the flash tank 10 in separating incoming fluid into intermediate-pressure vapor and sub-cooled liquid by maintaining the sub-cooled liquid within the shell 12 at a height approximately equal to two-thirds of the total height of the shell 12. This is accomplished by positioning the top disk 76 within the inner volume 20 at a height approximately equal to two-thirds of the total height of the shell 12.

[0070] With particular reference to FIG. 8, the flash tank 10 is shown including the inner shell 74 having a tube 83 extending from the top disk 76 generally toward the bottom portion 16 of the shell 12. The tube 83 allows fluid com-

munication between the bottom portion 16 of the shell 12 and the top portion 14 of the shell 12, and includes a central bore 85 extending along the length of the tube 83 and a bell-mouth opening 87. The tube 83 prevents the incoming fluid and/or sub-cooled liquid from reaching the top portion 14 of the shell 12 and mixing with the intermediate-pressure vapor stored within the top portion 14.

[0071] Movement of the incoming fluid into the bottom portion 16 of the shell 12 is generally along the inner surface 24 of the shell 18 due to the tangential relationship between the first port 22 and the shell 18. Interaction between the incoming fluid and the inner surface 24 causes the incoming flow to form a vortex (schematically represented as 89 in FIG. 8) within the shell 18. The tube 83 is positioned generally within the vortex 89 such that the incoming fluid swirls around the bell-mouth opening 87 and does not enter the central bore 85.

[0072] As described above, the incoming fluid is separated into a sub-cooled liquid and intermediate-pressure vapor. The positioning of the tube 83, in combination with the bell-mouth opening 87 and a diffuser 91 positioned on an opposite end of the tube 83 from the bell-mouth opening 87, cooperate to transfer intermediate-pressure vapor from the bottom portion 16 of the shell 12 to the top portion 14 of the shell 12 (i.e., through the top disk 76) without causing a drop in pressure. Therefore, the tube 83, bell-mouth opening 87, and diffuser 91, provide a low-pressure drop passage that allows fluid communication between the bottom portion 16 of the shell 12 and the top portion 14 of the shell 12 without reducing a pressure of the intermediate-pressure vapor as the intermediate-pressure vapor travels from the bottom portion 16 of the shell 12 to the top portion 14 of the shell 12.

[0073] By providing the top disk 76 with the tube 83, mixing of incoming fluid at the first port 22 and/or sub-cooled liquid with the intermediate-pressure vapor at the top portion 14 of the shell 12 is restricted to a desired mixing of "wet" injection (i.e., 5% liquid, as noted above).

[0074] With particular reference to FIG. 9, the flash tank 10 is shown incorporated into a refrigeration or cooling system 90 including an evaporator 92, a first expansion device 94, a condenser 96, and second expansion device 98. Each of the components of the refrigeration circuit 90 are fluidly coupled to a compressor 100 that circulates a fluid between the individual components.

[0075] In operation, vapor at discharge pressure is produced by the compressor 100 and exits the compressor 100 generally at a discharge fitting 102. The vapor, at discharge pressure, travels along a conduit 104 and enters the condenser 96. Once in the condenser 96, the discharge-pressure vapor changes phase from a high-pressure vapor to a liquid by rejecting heat. Once the high-pressure vapor has been converted to a liquid, the liquid exits the condenser 96 and travels along a conduit 106 toward the second expansion device 98. The second expansion device expands the liquid prior to the refrigerant reaching the fitting 34 of the flash tank 10. The expanded liquid enters the flash tank 10 generally at the fitting 34 and encounters the L-shaped elbow 26 and the first port 22.

[0076] As described above, the entering fluid first encounters the first chamber 38 of the L-shaped elbow 26 and then encounters the second chamber 40 of the L-shaped elbow 26

to reduce the velocity of the incoming fluid prior to the fluid reaching the first port 22. Once the incoming fluid exits the second chamber 40 the L-shaped elbow 26, the fluid passes through the first port 22 and is caused to engage the inner surface 24 of the middle portion 18 due to the tangential relationship between the first port 22 and the inner surface 24 of the middle portion 18. The incoming fluid travels along the inner surface 24 of the middle portion 18 and is prevented from rising within the shell 12 by the upper baffle 60.

[0077] Once the fluid is disposed within the bottom portion 16 of the shell 12, the fluid is separated into sub-cooled liquid and intermediate-pressure vapor. The sub-cooled liquid collects generally at the bottom portion 16 of the shell 12 while the intermediate-pressure vapor travels upwardly within the inner volume 20 through the aperture 64 of the upper baffle 60 and into the top portion 14 of the shell 12.

[0078] The sub-cooled liquid disposed within the bottom portion 16 of the shell 12, exits the inner volume 20 via the second port 42. The exiting sub-cooled liquid exits the second port 42 via fitting 44 and travels along a conduit 108 extending generally between the second port 42 of the flash tank 10 and the expansion device 94 located upstream of the evaporator 92. The sub-cooled liquid travels along the conduit 108 and passes through the expansion device 94. The sub-cooled liquid is expanded by the expansion device 94 and enters the evaporator 92 following expansion. Once in the evaporator 92, the sub-cooled liquid changes phase from a liquid to a vapor, thereby producing a cooling effect.

[0079] Once the sub-cooled liquid changes phase from a liquid to a vapor, the vapor exits the evaporator 92 and travels along a conduit 110, extending generally between the evaporator 92 and a suction port 112 of the compressor 100. The vapor is drawn from the conduit 110 and enters the compressor 100 at the suction port 112. Once the vapor reaches the compressor 100, the cycle begins anew and the compressor pressurizes the entering vapor to discharge pressure prior to dispensing the vapor at discharge pressure at discharge fitting 102.

[0080] The intermediate-pressure vapor disposed within the top portion 14 of the shell 12 is fed to the compressor 100 via the vapor injection arrangement 50. Specifically, the intermediate-pressure vapor is supplied to an injection port 114 of the compressor 100 at the outlet 54 of the vapor injection arrangement 50. The intermediate-pressure vapor, as described above, is at a lower pressure than discharge pressure but at a higher pressure than the vapor received at the suction port 112 of the compressor 100 (i.e., suction pressure). The intermediate-pressure vapor is injected at the injection port 114 and is only required to pass through a portion of the compressor 100 to reach discharge pressure due to its elevated pressure relative to suction pressure. Therefore, the work required by the compressor 100 in producing vapor at discharge pressure is reduced. By reducing the amount of work required by the compressor 100 in producing vapor at discharge pressure, energy associated with operation of the compressor 100 is reduced and the overall efficiency of the system 90 is improved. A solenoid valve 117 may be disposed and fluidly coupled near the injection port 114 to selectively close or open the injection flow as desired for capacity control.

[0081] With particular reference to FIG. 9, the flash tank 10 is shown incorporated into a heat pump system 116

capable of operating in a heating mode and a cooling mode. The heat pump system 116 includes a compressor 118 fluidly coupled to an indoor heat exchanger 120 and an outdoor heat exchanger 122. A four-way reversing valve 124 is disposed generally between the compressor 118 and the indoor and outdoor heat exchangers 120, 122 to direct fluid flow within the system 116. Specifically, when the four-way reversing valve 124 directs fluid from the compressor 118 towards the indoor heat exchanger 120, the heat pump system 116 operates in the heating mode and when the four way reversing valve 124 directs fluid flow from the compressor 118 towards the outdoor heat exchanger 122, the heat pump system 116 operates in the cooling mode.

[0082] A check valve 126 and a control device 128 are associated with the indoor heat exchanger 120. The control device 128 may be either a thermal expansion valve, an electronic expansion valve, or a fixed orifice. If the control device 128 is a thermal expansion valve, a pressure tap 130 and a bulb 132 may be fluidly coupled on an opposite side of the indoor heat exchanger 120 from the thermal expansion valve 128 for use in controlling the thermal expansion valve 128. While the check valve 126 and control device 128 are shown as separate and discrete elements, the check valve 126 and control device 128 may be a single integrated unit commercially available provided in fluid communication with the indoor heat exchanger 120.

[0083] The outdoor heat exchanger 122 similarly includes a check valve 134 and a control device 136. The control device 136 may be a thermal expansion valve, an electronic expansion valve, or a fixed orifice. If the control device 136 is a thermal expansion valve, a pressure tap 138 and bulb 140 may be positioned on an opposite side of the outdoor heat exchanger 122 from the thermal expansion valve 136 for use in controlling the thermal expansion valve 136. While the check valve 134 and control device 136 are shown as separate elements, the check valve 134 and control device 136 could be included as a single integrated unit commercially available fluidly coupled to the outdoor heat exchanger 122.

[0084] If either of the control devices 128, 136 respectively associated with the indoor heat exchanger 120 and the outdoor heat exchanger 122 is a fixed orifice or a capillary tube, an accumulator 142 should be provided. Because a fixed orifice and a capillary tube cannot be adjusted for heating or cooling load variation, the accumulator 142 may be required to keep a reserve of refrigerant in fluid communication with the compressor 118 and heat exchangers 120, 122 in case the load causes excessive refrigerant to return to a suction side of the compressor. Therefore, if a fixed orifice or a capillary tube is to be used for either of the control devices 128, 136 associated with the indoor heat exchanger 120 or the outdoor heat exchanger 122, the accumulator tank 142 may be required.

[0085] The flash tank 10 is shown fluidly coupled to the compressor 118, the indoor heat exchanger 120, and the outdoor heat exchanger 122. A check valve 144 and a control device 146 are disposed generally between the flash tank 10, the check valve 126, and the control device 128 of the indoor heat exchanger 120. The control device 146 may be a thermal expansion device, an electronic expansion device, or a fixed orifice. If the control device 146 is a thermal expansion device, a pressure tap 147 and bulb 149 can be

fluidly coupled to the conduit 156 right after the second port 44 of the flash tank 10. Again, while the check valve 144 and control device 146 are shown as separate elements, the check valve 144 and control device 146 may be configured as a single unit fluidly coupled between the check valve 126 and control device 128 associated with the indoor heat exchanger 120 and the flash tank 10.

[0086] The vapor injection arrangement 50 of the flash tank 10 is fluidly coupled to a vapor injection port 148 of the compressor 118 to selectively supply the compressor 118 with intermediate-pressure vapor during operation of the heat pump system 116. A solenoid valve 150 is disposed generally between the outlet 54 of the vapor injection arrangement 50 and the vapor injection port 148 of the compressor 118. The solenoid valve 150 may be a solenoid valve or any suitable device for use in controlling injection flow to the compressor 118 to control capacity as needed. The solenoid valve 150 is preferably located as close as possible to the injection port 148 of the compressor 118 to minimize compressed gas re-expansion loss.

[0087] While a fixed orifice is described as being an option for the control devices 128, 146, the fixed orifice could alternatively be a capillary tube. Furthermore, while the control devices 128, 146 are described generically as being electronic expansion valves, such electronic expansion valves may include stepper-motor-driven solenoids or pulse-width modulated solenoids.

[0088] With reference to FIG. 10, operation of the heat pump system 116 will be described in detail. As previously discussed, the heat pump system 116 is operable in a heating mode and a cooling mode. The flash tank 10 selectively provides intermediate-pressure vapor to the vapor injection port 148 of the compressor 118 in the heating mode by opening solenoid valve 150. In the cooling mode, the flash tank 10 acts as a receiver by closing solenoid valve 150, whereby intermediate-pressure vapor is prevented from reaching the vapor injection port 148 of the compressor 118. The liquid refrigerant is slightly subcooled by the receiver (i.e., flash tank 10), thus reducing the amount of subcooling required to be produced by the condenser (i.e., outdoor heat exchanger 122) thereby slightly reducing the condenser charge and pressure required in the cooling mode.

[0089] In the cooling mode, the compressor 118 provides vaporized refrigerant at discharge pressure to the four-way reversing valve 124 via a conduit 152. If either or both of the indoor heat exchanger 120 and outdoor heat exchanger 122 include use of a fixed orifice or a capillary tube as the control device 128, 136, the required accumulator 142 may be fluidly coupled between the compressor 118 and the four-way reversing valve 124 along the conduit 174. The vapor refrigerant at discharge pressure travels through the conduit 152 and encounters the four-way reversing valve 124, which directs the vaporized refrigerant at discharge pressure generally toward the outdoor heat exchanger 122 along a conduit 154.

[0090] The vaporized refrigerant at discharge pressure enters the outdoor heat exchanger 122 and rejects heat, thereby changing state from a high pressure vapor to a liquid. In this manner, the outdoor heat exchanger 122 functions as a condenser in the cooling mode.

[0091] Once the vaporized refrigerant sufficiently changes state from a vapor to a liquid, the liquid refrigerant exits the

outdoor heat exchanger 122 and flows through the check valve 134, bypassing the control device 136. The liquid refrigerant travels through the check valve 134 to the second port 44 of the flash tank 10 via a conduit 156. The liquid refrigerant enters the flash tank 10 at the second port 44 and is received generally within the bottom portion 16 of the shell 12.

[0092] The liquid refrigerant disposed within the inner volume 20 of the flash tank 10 is only permitted to reach a level approximately equal to one-third the total height of the shell 12, as the first port 22 acting as outlet port in the cooling mode is disposed at a height approximately equal to one-third the total height of the shell 12. Therefore, when liquid entering at the second port 44 acting as inlet port in the cooling mode reaches a height approximately equal to one-third the total height of the shell 12, the liquid encounters the first port 22 and exits the interior volume 20 of the flash tank 10 via the L-shaped elbow 26.

[0093] The entering liquid at the second port 44 does not separate into a sub-cooled liquid refrigerant and intermediate-pressure vapor as the solenoid valve 150 disposed along a conduit 158 extending generally between the outlet 54 of the vapor injection arrangement 50 and the vapor injection port 148 of the compressor 118 remains closed. Because the solenoid valve 150 remains closed, intermediate-pressure vapor is not permitted to escape from the inner volume 20 of the flash tank 10 and travel along the conduit 158 towards the compressor 118. Because the intermediate-pressure vapor is not permitted to travel along the conduit 158 and enter the compressor 118, liquid refrigerant entering the flash tank 10 is not permitted to expand into an intermediate-pressure vapor and a sub-cooled liquid refrigerant. Because the liquid refrigerant entering the flash tank 10 is not permitted to separate into an intermediate-pressure vapor and a sub-cooled liquid, the entering fluid merely resides within the bottom portion 16 of the shell 12, thereby causing the flash tank 10 to act as a receiver during the cooling mode.

[0094] When the liquid refrigerant disposed within the bottom portion 16 of the shell 12 reaches the first port 22, the liquid refrigerant enters the first port 22 and exits the shell 12 via the L-shaped elbow 26. The liquid refrigerant first encounters the second chamber 40 of the L-shaped elbow 26 and travels through the second chamber 40 until exiting the L-shaped elbow 26 via the first chamber 38 and fitting 34. Once the liquid refrigerant exits the flash tank 10 at the fitting 34, the liquid refrigerant travels along a conduit 160 disposed generally between the fitting 34 and the check valve 144. The liquid refrigerant encounters the check valve 144 and passes therethrough, thereby bypassing the control device 146.

[0095] Once the liquid refrigerant bypasses the control device 146 via the check valve 144, the liquid refrigerant travels along a conduit 162 extending generally between the check valve 144 and the check valve 126. The liquid refrigerant travels along the conduit 162 and engages the check valve 126 associated with the indoor heat exchanger 120.

[0096] The check valve 126 causes the liquid refrigerant to travel along a conduit 164 and engage the control device 128. The control device expands the liquid refrigerant prior to the liquid refrigerant reaching the indoor heat exchanger 120. If the control device 128 is a fixed orifice, the degree

to which the fluid refrigerant is expanded prior to reaching the indoor heat exchanger **120** is fixed. However, if the control device **128** is one of a thermal expansion device and or an electronic expansion device, the control device **128** may regulate the amount of expansion of the liquid refrigerant based on the demand for cooling.

[0097] The expanded refrigerant exits the control device **128** and enters the indoor heat exchanger **120** via conduits **166** and **168**. Once the refrigerant enters the indoor heat exchanger **120**, the refrigerant absorbs heat from the surroundings and changes state from a liquid into a gas. In this manner, the indoor heat exchanger **120** functions as an evaporator on the cooling mode.

[0098] Once the refrigerant has sufficiently changed state from a liquid to a gas, the refrigerant exits the indoor heat exchanger **120** and travels back to the four-way reversing valve **124** via a conduit **170**. The four-way reversing valve **124** directs the vaporized refrigerant to a suction port **172** of the compressor **118** via a conduit **174**.

[0099] In the heating mode, the four-way reversing valve reverses the flow of refrigerant within the heat pump **116** such that the indoor heat exchanger **120** functions as a condenser and the outdoor heat exchanger **122** functions as an evaporator. In operation, the compressor **118** supplies vaporized refrigerant at discharge pressure to the four-way reversing valve **124** via conduit **152**. The four-way reversing valve directs the vaporized refrigerant at discharge pressure to the indoor heat exchanger **120** via conduit **170**. The vaporized refrigerant at discharge pressure enters the indoor heat exchanger **120** and rejects heat, thereby changing state from a vapor to a liquid.

[0100] Once the refrigerant has sufficiently changed state from a high-pressure vapor to a liquid, the liquid refrigerant exits the indoor heat exchanger **120** via conduit **168** and engages the check valve **126**. The check valve allows the liquid refrigerant to pass therethrough and travel generally towards the check valve **144** along conduit **162**, thereby bypassing control device **128**. The liquid refrigerant encounters the check valve **144** and is restricted from entering the fitting **34** of the flash tank **10** without first passing through the control device **146**. The liquid engages the check valve **144** and is directed towards the control device **146** along a conduit **176**. The liquid refrigerant is expanded by the control device **146** and is then directed to the fitting **34** of the flash tank **10** via conduits **160** and **178**. The expanded refrigerant enters the inner volume **20** of the flash tank **10** via the fitting **34**, the L-shaped elbow **26**, and the first port **22**. As described above, the velocity and turbulence of the incoming refrigerant is slowed due to the relationship of the second chamber **40** of the L-shaped elbow **26** and the tangential relationship of the first port **22** with the inner surface **24** of the shell **12**.

[0101] Once the liquid refrigerant enters the inner volume **20** of the flash tank **10**, the liquid refrigerant is expanded into a high-pressure vaporized refrigerant and a sub-cooled liquid refrigerant.

[0102] The sub-cooled liquid refrigerant is collected generally at the bottom portion **16** of the shell **12** while the intermediate-pressure vapor is collected generally near the top portion **14** of the shell **12**.

[0103] The intermediate-pressure vapor is fed to the vapor injection port **148** of the compressor **118** via conduit **158**.

The vapor injection arrangement **50** provides the intermediate-pressure vapor to the vapor injection port **148** of the compressor **118** via outlet **54**, conduit **158**, and solenoid valve **150**. The control device also may be controlled based on the demand for heating. If ambient outdoor temperatures are low, preferably below 25 degrees Fahrenheit, the solenoid valve **150** is required to more fully open and allow more intermediate-pressure vapor to enter the compressor **118** via vapor injection port **148**. Conversely, if outdoor ambient temperatures are high, preferably above 45 degrees Fahrenheit, the solenoid valve **150** will restrict flow through the conduit **158** to restrict the amount of intermediate-pressure vapor received by the compressor **118** at the vapor injection port **148**.

[0104] Solenoid valve **150** may also be pulse-width modulated as a function of outdoor temperature. For example, the solenoid valve **150** may be fully open to maximize the capacity of the heat pump at lower outdoor temperatures (i.e., at outdoor ambient temperature less than 25 degrees Fahrenheit) to reduce use of supplementary heaters (i.e., resistance electric heaters). Conversely, the solenoid valve **150** may be closed to minimize the capacity of the heat pump at higher outdoor ambient temperatures (i.e., at outdoor ambient temperatures above 45 degrees Fahrenheit) to reduce on/off cycling loss. The solenoid valve **150** may be pulse-width modulated when the outdoor ambient temperature is between 25 degrees Fahrenheit and 45 degrees Fahrenheit.

[0105] Providing the compressor **118** with intermediate-pressure vapor at the vapor injection port **148** reduces the amount of work required by the compressor **118** in producing vaporized refrigerant at discharge pressure. Specifically, because the intermediate-pressure vapor is at a lower pressure than discharge pressure, but at a higher pressure than suction pressure, the compressor is required to do less work in pressurizing the intermediate-pressure vapor to discharge pressure when compared to the work required in compressing vapor at suction pressure to discharge pressure.

[0106] The sub-cooled liquid refrigerant disposed within the bottom portion **16** of the shell **12** exits the flash tank **10** at the second port **44** and travels generally toward the check valve **134** along conduit **156**. When the sub-cooled liquid refrigerant encounters the check valve **134**, the check valve causes the sub-cooled liquid refrigerant to travel along a conduit **180** and engage the control device **136**. The control device **136** expands the sub-cooled liquid refrigerant prior to the refrigerant entering the outdoor heat exchanger **122**. Once the refrigerant is expanded by the control device **136**, the expanded refrigerant travels along a pair of conduits **182**, **184** and is received by the outdoor heat exchanger **122**. The expanded refrigerant releases heat and therefore changes state from a liquid to a vapor. Once the refrigerant has sufficiently changed state from a liquid to a vapor, the vapor exits the outdoor heat exchanger **122** and travels to the four-way reversing valve **124** via conduit **154**. Upon reaching the four-way reversing valve **124**, the vapor then travels back to the suction port **172** of the compressor **118** via conduit **174** to begin the cycle anew.

[0107] The positioning of the L-shaped elbow **26** relative to the bottom portion **16** of the flash tank **10** allows the flash tank **10** to be used as a flash tank in the heating mode and as a receiver in the cooling mode. In the cooling mode, the

flash tank **10** operates as a receiver and therefore basically allows the received refrigerant to pass through the flash tank **10** without expanding. Therefore, the lower the L-shaped elbow **26** is to the bottom portion **16** of the shell **12**, the less refrigerant (i.e., charge) that is required within the system **116**. However, for the heating mode, the flash tank **10** functions as a flash tank and separates the received refrigerant into an intermediate-pressure vapor and a sub-cooled liquid refrigerant. Therefore, the more refrigerant received by the flash tank **10**, the more intermediate-pressure vapor and sub-cooled liquid refrigerant that can be produced.

[0108] If the flash tank **10** were solely used in a system having a heating mode, the L-shaped elbow **26** could be positioned substantially at a middle portion of the shell **12**, generally equidistant from the bottom portion **16** and the top portion **14**, to maximize the amount of sub-cooled liquid and intermediate-pressure vapor within the shell.

[0109] However, for heat pump systems functioning in both a heating mode and a cooling mode, such as heat pump **116**, positioning the L-shaped elbow **26** at the middle of the shell **12** requires more refrigerant (i.e., charge) to be supplied to the heat pump **116** so that the entering refrigerant at the second port **44** in the cooling mode can sufficiently fill the inner volume **20** and reach the L-shaped elbow **26** and exit the shell **12**.

[0110] In light of the foregoing, the L-shaped elbow **26** is positioned a distance away from the bottom of the flash tank **10** approximately equal to one-third a total height of the shell **12**. This position allows the heat pump system **116** to include a lower charge in the cooling mode than would otherwise be required if the L-shaped elbow **26** were positioned at a higher point along the shell **12** (i.e., such as the midpoint of the shell **12**) and allows the flash tank **10** to produce a sufficient amount of intermediate-pressure vapor for use by the vapor injection arrangement **50** during the heating mode.

[0111] High-efficiency heat pump systems tend to have much larger internal volume in the outdoor heat exchanger **122** than the indoor heat exchanger **120**. Therefore, the minimum charge required is reduced and the charge requirement for the cooling and heating modes is balanced without the need for a "charge robbing" device such as an empty volume or tank that allows for removal of excess charge.

[0112] For the heat pump system **116**, control devices **146** and **128**, together with their check valves **144** and **126**, can be replaced by a single bi-directional electronic expansion valve, preferably located at the indoor unit **120** at the same location as control device **128**. With this arrangement, the fluid conduit **162** will contain liquid refrigerant in the cooling mode and expanded refrigerant in the heating mode.

[0113] For the heat pump system **116**, the solenoid valve **150** may be open in the cooling mode to introduce a significant amount of liquid instead of vapor into the compressor **118** at a much higher injection pressure than the heating mode since the liquid is not expanded down to a lower pressure when entering the receiver (i.e., flash tank **10**). This is commonly referred to as a "liquid injection" system instead of a vapor injection system. Liquid injection may be used at a high outdoor temperature to provide internal cooling to the compressor **118** as needed.

[0114] With particular reference to FIG. **11**, another heat pump system **116a** is provided. In view of the substantial

similarity in structure and function of the components associated with the heat pump system **116** with respect to the heat pump system **116a**, like reference numerals are used hereinafter and in the drawings to identify like components, while like reference numerals containing letter extensions are used to identify those components that have been modified.

[0115] The heat pump system **116a** is similar to the heat pump system **116**, with the exception that the vapor injection arrangement **50** is used in both the heating mode and the cooling mode. In this arrangement, the solenoid valve **150** could be eliminated and injection to port **148** is dependent on whenever the compressor **118** is operating. To achieve this, a check valve **186** and a control device **188** are fluidly coupled between the second port **44** of the flash tank **10** and the check valve **134** and control device **136** of the outdoor heat exchanger **122**, generally along conduit **156**.

[0116] In operation, the compressor **118** supplies vapor at discharge pressure to the four-way reversing valve **124** via conduit **152**. If either of the indoor heat exchanger **120** or the outdoor heat exchanger **122** incorporates a fixed orifice for use as the control device **128**, **136**, an accumulator **142** may be required. Under such circumstances, the compressor **118** supplies vapor at discharge pressure to the four-way reversing valve **124** via conduit **152** and accumulator **142**.

[0117] The four-way reversing valve **124**, upon receiving the vaporized refrigerant at discharge pressure, directs the vaporized refrigerant at discharge pressure towards the outdoor heat exchanger **122** in the cooling mode. The vaporized refrigerant enters the outdoor heat exchanger **122** and is converted therein from a vapor to a liquid.

[0118] Once the vaporized refrigerant has been sufficiently converted from a vapor to a liquid, the liquid refrigerant exits the outdoor heat exchanger **122** along conduit **184** and passes through the check valve **134** and is directed toward the flash tank **10** via conduit **156**. The liquid refrigerant travels along the conduit **156** and encounters the check valve **186**. The check valve **186** causes the liquid refrigerant to travel along a conduit **190** and encounter the control device **188**. The control device **188** may be one of a thermal expansion valve, an electronic expansion valve, or a fixed orifice, and serves to expand the liquid refrigerant prior to the liquid refrigerant entering the flash tank **10**.

[0119] Upon expansion by the control device **188**, the liquid refrigerant travels along conduits **192**, **194** prior to being received by the flash tank **10**. The expanded liquid refrigerant is received by the flash tank **10** at the second port **44** and is expanded within the inner volume **20** of the shell **12** into an intermediate-pressure vapor and a sub-cooled liquid refrigerant. The intermediate-pressure vapor is directed toward the vapor injection port **148** of the compressor **118** by the vapor injection arrangement **50**.

[0120] The vapor injection arrangement **50** directs the intermediate-pressure vapor to the vapor injection port **148** of the compressor **118** via outlet **54**, conduit **158**, and solenoid valve **150** if used. The solenoid valve **150** may be controlled based on the demand for cooling and can be controlled as a function of outdoor ambient temperatures. For example, solenoid valve **150** can be turned off at a maximum outdoor temperature (125 degrees Fahrenheit) to reduce peak load on a utility power grid or turned on to allow

the compressor **118** to provide a greater cooling effect at a high efficiency. Likewise, solenoid valve **150** can be turned on at the rated full-load outdoor ambient temperature (i.e., 95 degrees Fahrenheit) to increase the system rated nominal capacity (i.e., at full load) and turned off at lower outdoor temperature (i.e., 82 degrees Fahrenheit) to reduce capacity at part-load (i.e., a lower load) to increase system efficiency through reduced heat exchanger loading.

[0121] The sub-cooled liquid refrigerant disposed within the bottom portion **16** of the shell **12** exits the interior volume **20** via first port **22** and L-shaped elbow **26**. The sub-cooled liquid refrigerant travels through the L-shaped elbow **26** and the fitting **34** generally toward the check valve **144** via conduit **160**. The sub-cooled liquid refrigerant travels through the check valve **144**, bypassing the control device **146**, and continues along conduit **162** generally toward the check valve **126**. The check valve **126** causes the sub-cooled liquid refrigerant to travel along conduit **164** and encounter the control device **128**. The control device **128** expands the sub-cooled liquid refrigerant and directs the expanded refrigerant toward the indoor heat exchanger **120** via conduits **166** and **168**.

[0122] Once the expanded refrigerant is within the indoor heat exchanger **120**, the expanded refrigerant absorbs heat and in so doing, changes state from a liquid to a vapor. Once the refrigerant has sufficiently changed state from a liquid to a vapor, the vaporized refrigerant exits the indoor heat exchanger **120** and travels along conduit **170** generally towards the four-way reversing valve **124**. The four-way reversing valve **124** receives the vaporized refrigerant and directs the vaporized refrigerant to the suction port **172** of the compressor **118** via conduit **174** to begin the process anew.

[0123] In the heating mode, the compressor **118** provides vapor at discharge pressure to the four-way reversing valve **124** via conduit **152**. Again, the indoor heat exchanger **120** or the outdoor heat exchanger **122** includes a fixed orifice as the control device **128**, **136**, and accumulator **142** may be required. Under such circumstances, the compressor **118** provides vapor at discharge pressure to the four-way reversing valve **124** via conduit **152**.

[0124] The four-way reversing valve **124** directs the vapor at discharge pressure toward the indoor heat exchanger **120** when in the heating mode. The vaporized refrigerant enters the indoor heat exchanger **120** and rejects heat, thereby changing phase from a high-pressure vapor to a liquid. Once the refrigerant has sufficiently changed phase from a vapor to a liquid, the liquid refrigerant exits the indoor heat exchanger **120** via conduit **168**.

[0125] The exiting refrigerant travels along conduit **168** and encounters the check valve **126**. The check valve **126** allows the liquid refrigerant to bypass the control device **128** and travel along conduit **162** generally toward the check valve **144**. The check valve **144** directs the liquid refrigerant through conduit **176** to the control device **146**. The control device **146** expands the liquid refrigerant prior to directing the liquid refrigerant to the flash tank **10**.

[0126] The expanded refrigerant exits the control device **146** and travels to the fitting **34** of the L-shaped elbow **26** via conduits **178** and **160**. The expanded refrigerant enters the flash tank **10** via the fitting **34**, the L-shaped elbow **26**, and the first port **22**.

[0127] Once the expanded refrigerant enters the inner volume **20** of the flash tank **10**, the refrigerant is expanded into an intermediate-pressure vapor and a sub-cooled liquid refrigerant. The intermediate-pressure vapor is supplied to the injection port **148** of the compressor **118** by the vapor injection arrangement **50**. Specifically, the vapor injection arrangement **50** directs the intermediate-pressure vapor toward the injection port **148** of the compressor **118** via outlet **54**, conduit **158**, and solenoid valve **150**. The solenoid valve **150** may be controlled based on outdoor ambient temperature, as described above.

[0128] The sub-cooled liquid refrigerant disposed generally within the bottom portion **116** of the shell **12** exits the flash tank **10** via the second port **44**. The exiting sub-cooled liquid refrigerant travels toward the check valve **186** via conduit **194** and bypasses the control device **188**. Once the sub-cooled liquid refrigerant has passed through the check valve **186**, the sub-cooled liquid refrigerant travels along conduit **156** generally towards the check valve **134**.

[0129] The check valve **134** causes the sub-cooled liquid refrigerant to travel along the conduit **180** and generally towards the control device **136**. The control device **136** expands the sub-cooled liquid refrigerant prior to directing the sub-cooled liquid refrigerant to the outdoor heat exchanger **122**. Once the refrigerant has been sufficiently expanded, the refrigerant is directed to the outdoor heat exchanger **122** via conduits **182** and **184**. Once disposed within the outdoor heat exchanger **122**, the liquid refrigerant absorbs heat and changes state from liquid to a vapor. Once the refrigerant has sufficiently changed state from a liquid to a vapor, the vaporized refrigerant is directed toward the four-way reversing valve **124** via conduit **154**. The four-way reversing valve **124** directs the vaporized refrigerant toward the suction port **172** of the compressor **118** via conduit **174** to begin the cycle anew.

[0130] With particular reference to FIG. **12**, another heat pump system **116b** is provided. In view of the substantial similarity in structure and function of the components associated with the heat pump system **116** with respect to the heat pump system **116b**, like reference numerals are used hereinafter and in the drawings to identify like components, while like reference numerals containing letter extensions are used to identify those components that have been modified.

[0131] The heat pump system **116b** is similar to the heat pump systems **116** and **116a**, however, the flash tank **10** is replaced with a plate heat exchanger **196** for supplying vapor to the vapor injection port **148** of the compressor **118**. This heat exchanger can be of a shell-and-tube or micro-channel type, but the plate heat exchanger design is the most common and minimizes charge requirement. The plate heat exchanger **196** includes a vapor side **198** and a sub-cooled liquid side **200** and is fluidly coupled between the indoor heat exchanger **120** and the outdoor heat exchanger **122**. A control device **202** is disposed at an inlet **204** of the vapor side **198** to expand liquid refrigerant prior to the liquid refrigerant entering the vapor side **198**. The control device **202** in conjunction with the vapor side **198** creates a stream of intermediate-pressure vapor for use by a vapor injection arrangement **50b**. The vapor injection arrangement **50b** provides the intermediate-pressure vapor to the vapor injection port **148** of the compressor **118** to improve the overall efficiency and performance of the compressor **118**.



[0132] With continued reference to FIG. 12, operation of the heat pump system 116b will be described. In a cooling mode, the compressor 118 supplies vapor at discharge pressure to the four-way reversing valve 124 via conduit 152. If the indoor heat exchanger 120 or the outdoor heat exchanger 122 include a fixed orifice for the control devices 128, 136, an accumulator 142 may be required. Under such circumstances, the compressor 118 supplies vapor at discharge pressure to the four-way reversing valve 124 via conduit 152 and accumulator 142.

[0133] The four-way reversing valve 124 directs the vapor at discharge pressure towards the outdoor heat exchanger 122. The outdoor heat exchanger 122 receives the high-pressure vapor from the four-way reversing valve 124 and causes the high-pressure vapor to release heat, thereby causing the vapor to change phase into a liquid. Once the refrigerant has sufficiently changed phase from a vapor to a liquid, the liquid refrigerant exits the outdoor heat exchanger 122 along conduit 184. The liquid refrigerant travels along conduit 184 and encounters the check valve 134, thereby bypassing the control device 136. The liquid refrigerant continues on conduit 184 through the check valve 134 and continues past the check valve 134 and into conduit 156.

[0134] The liquid refrigerant travels via conduit 156 generally towards the plate heat exchanger 196 and flows into a conduit 206 directing the liquid refrigerant toward the vapor side 198 of the plate heat exchanger 196 and also to a conduit 208 directing the liquid refrigerant to the sub-cooled liquid side 200 of the plate heat exchanger 196.

[0135] The liquid refrigerant disposed within the conduit 206 encounters the control device 202 located upstream of the inlet 204 of the vapor side 198. The control device 202 may be a thermal expansion valve, an electronic expansion valve, or a fixed orifice. If the control device 202 is a thermal expansion valve, a pressure tap 210 and a bulb may be positioned generally downstream of an outlet 214 of the vapor side 198, generally between outlet 214 and the vapor injection port 148 of the compressor 118. The pressure tap 210 and bulb 212 are used in controlling the thermal expansion device 202 located upstream of the inlet 204 to the vapor side 198.

[0136] The liquid refrigerant disposed within conduit 206 is received by the control device 202 and is expanded prior to reaching the inlet 204 of the vapor side 198. Once the liquid refrigerant has been sufficiently expanded by the control device 202, the expanded refrigerant enters the vapor side 198 of the plate heat exchanger 196 at the inlet 204. Once in the vapor side 198, the liquid refrigerant extracts heat associated with the liquid refrigerant flowing through conduit 208 in the liquid side 200 of the plate heat exchanger 196.

[0137] In this manner, as the liquid refrigerant flows through the conduit 208 in the liquid side 200 of the plate heat exchanger 196, heat is lost to the vapor side 198 of the plate heat exchanger 196, thereby converting the liquid refrigerant entering the liquid side 200 of the plate heat exchanger 196 into sub-cooled liquid refrigerant. The heat absorbed from the liquid refrigerant passing through the liquid side 200 of the plate heat exchanger 196 is absorbed by the liquid refrigerant entering the vapor side 198 of the plate heat exchanger 196 causing the liquid within the vapor side 198 to expand and create a flow of intermediate-pressure vapor.

[0138] The intermediate-pressure vapor exits the vapor side 198 of the plate heat exchanger 196 at the outlet 214 and travels along conduit 158 to the vapor injection port 148 of the compressor 118. As described previously with respect to heat pump systems 116 and 116a, the intermediate-pressure vapor received by the compressor 118 at the vapor injection port 148 increases the ability of the compressor 118 to produce vapor at the discharge pressure. Therefore, by producing the intermediate-pressure vapor at the plate heat exchanger 196 and supplying the intermediate-pressure vapor to the compressor 118, the overall efficiency of the compressor 118 and system 116b is improved.

[0139] The solenoid valve 150 is disposed generally between the outlet 214 of the vapor side 198 and the vapor injection port 148 of the compressor 118 and controls the amount of intermediate-pressure vapor received by the vapor injection port 148, as described above.

[0140] The sub-cooled liquid created by the liquid side 200 of the plate heat exchanger 196 exits the plate heat exchanger and travels along a conduit 162 generally towards the check valve 126. The check valve 126 forces the sub-cooled liquid refrigerant to travel along a conduit 164 and encounter the control device 128. The control device 128 expands the liquid refrigerant prior to the refrigerant entering the indoor heat exchanger 120. Once the refrigerant has been sufficiently expanded by the control device 128, the refrigerant travels to the indoor heat exchanger 120 via conduits 166 and 168. The sub-cooled liquid refrigerant received in the indoor heat exchanger 120 rejects heat and in so doing, changes phase from a liquid to a vapor. Once the refrigerant has been sufficiently converted from a liquid to a vapor, the vaporized refrigerant exits the indoor heat exchanger 120 and travels towards the four-way reversing valve 124 via conduit 170. The four-way reversing valve 120 directs the vaporized refrigerant toward the suction port 172 of the compressor 118 via conduit 174 to begin the cycle anew.

[0141] In the heating mode, the compressor 118 produces vapor at the discharge pressure and directs the vapor toward the four-way reversing valve 124 via conduit 152. Again, if the indoor heat exchanger 120 or the outdoor heat exchanger 122 includes a fixed orifice as the control device 128, 136, an accumulator 142 may be required. Under such circumstances, the compressor 118 provides vapor at discharge pressure to the four-way reversing valve via conduit 152.

[0142] The four-way reversing valve 124 directs the vapor at discharge pressure towards the indoor heat exchanger 120 via conduit 170. The indoor heat exchanger 120 receives the high pressure vapor from the four-way reversing valve 124 and causes the high pressure vapor to reject heat, thereby causing the refrigerant to change phase from a vapor to a liquid. Once the refrigerant has sufficiently changed phase from a vapor to a liquid, the liquid refrigerant exits the indoor heat exchanger 120 and travels towards the check valve 126 via conduit 168.

[0143] The check valve allows the liquid refrigerant to bypass the control device 128 and continue on towards the plate heat exchanger 196 via conduit 162. The liquid refrigerant travels along conduit 162 and is received by the liquid side 200 of the plate heat exchanger 196. The liquid refrigerant travels through the liquid side 200 of the plate heat exchanger 196 via conduit 208. Once the liquid refrigerant

encounters conduit 208, the refrigerant travels through conduit 208 and into conduit 206.

[0144] The liquid refrigerant received in conduit 206 encounters the control device 202 and is expanded by the control device 202 once therein. The expanded liquid refrigerant exits the control device 202 and enters the vapor side 198 of the plate heat exchanger 196 at the inlet 204.

[0145] The vapor side 198 of the plate heat exchanger 196 causes the expanded liquid refrigerant therein to absorb heat from the refrigerant passing through the liquid side 200 of the plate heat exchanger 196. In so doing, the refrigerant passing through the vapor side 198 is converted into an intermediate-pressure vapor and the refrigerant passing through the liquid side 200 is converted into a sub-cooled liquid refrigerant. In this arrangement, the vapor side 198 and liquid side 200 include a counter flow configuration in the heating mode and a parallel flow configuration in cooling mode.

[0146] The intermediate-pressure vapor exits the vapor side 198 of the plate heat exchanger 196 at the outlet 214 and is directed by the vapor injection arrangement 50b towards the vapor injection port 148 of the compressor 118. The intermediate-pressure vapor travels along conduit 158 and through the solenoid valve 150 prior to reaching the vapor injection port 148 of the compressor 118.

[0147] In the heating mode, as the outdoor ambient temperature falls, the solenoid valve 150 allows more intermediate-pressure vapor to reach the vapor injection port 148 of the compressor 118. Allowing more intermediate-pressure vapor to reach the compressor 118 improves the ability of the compressor 118 to produce vapor at the discharge pressure. Allowing the compressor 118 to produce more vapor at discharge pressure improves the ability of the heat pump system 116b in producing heat, and therefore improves the overall performance and efficiency of the system 116b.

[0148] The sub-cooled liquid refrigerant created by the liquid side 200 of the plate heat exchanger 196 travels along conduit 208 and conduit 156 generally towards the check valve 134. The check valve 134 causes the sub-cooled liquid refrigerant to travel along conduit 180 and encounter control device 136. The control device 136 expands the sub-cooled liquid refrigerant prior to the sub-cooled liquid refrigerant entering the outdoor heat exchanger 122. Once the sub-cooled liquid refrigerant has been sufficiently expanded by the control device 136, the expanded refrigerant travels into the outdoor heat exchanger 122 via conduits 182 and 184.

[0149] The outdoor heat exchanger 122 receives the expanded refrigerant and causes the refrigerant to absorb heat and change phase from a liquid to a vapor. Once the refrigerant has been sufficiently converted from a liquid to a vapor, the vaporized refrigerant exits the outdoor heat exchanger 122 and travels along conduit 154 generally towards the four-way reversing valve 124. The four-way reversing valve 124 directs the vaporized refrigerant to the suction port 172 of the compressor 118 via conduit 174 to begin the process anew.

[0150] With particular reference to FIGS. 13 and 14, in any of the foregoing heat pump systems 116, 116a and 116b, ceasing operation of the respective systems 116, 116a, 116b may cause transient flow of refrigerant within the systems

116, 116a, 116b. For example, with respect to heat pump system 116, when operation of the compressor 118 is stopped and the control valve 150 is left open, migration of refrigerant generally from the flash tank 10 to the compressor 118 occurs until the refrigerant in the system 116 reaches a steady state condition. Similarly, if the control device 136 associated with the outdoor heat exchanger 122 is left open, refrigerant disposed generally between the flash tank 10 and the outdoor heat exchanger 122 is also in a transient state and may migrate to the suction port 172 of the compressor 118 until the refrigerant within the system reaches a steady state condition (i.e., equalized).

[0151] While the following technique can be used to prevent migration of refrigerant in any of the foregoing heat pump systems 116, 116a, or 116b, the following procedure will be described with respect to heat pump system 116a, as heat pump system 116a includes vapor injection in both the heating mode and the cooling mode. When a shutdown of the compressor 118 is imminent due to achieving a desired indoor temperature (i.e., heating or cooling), one, or both of, the control devices 136, 150 may be closed to prevent refrigerant migration within the heat pump system 116a.

[0152] The control devices 136, 150 may be closed a predetermined amount of time prior to shut down of the compressor 118 to avoid refrigerant migration. By closing the solenoid valve 150 a predetermined amount of time prior to shut down of the compressor 118, migration of refrigerant from the upper portion 14 of the flash tank 10 to the vapor injection port 148 of the compressor 118 is prevented. Similarly, by closing the control device 136 a predetermined amount of time prior to shut down of the compressor 118, migration of refrigerant from the outdoor heat exchanger 122 to the suction port 172 of the compressor 118 is prevented.

[0153] Preventing migration of refrigerant through the control devices 136 and 150 and into the compressor 118 protects the compressor 118 from a flooded start condition. Specifically, if the control devices 136 and 150 remain open when the compressor 118 is shut down, the refrigerant within the system 116a is allowed to migrate within the system 116a and may enter the compressor 118. When the compressor 118 is started again, excess refrigerant located within the compressor 118 may include liquid refrigerant, which may cause harm to the compressor 118.

[0154] With the control devices 136 and 150 in the closed position, the compressor 118 may be safely started as refrigerant is prevented from migrating into the compressor 118. Upon start up of the compressor 118, the control devices 136 and 150 may remain in the closed position for a pre-determined amount of time to allow the refrigerant to fill the flash tank 10 and outdoor heat exchanger 122 and stabilize before opening the respective control devices 136 and 150.

[0155] As described above, the control devices 136 and 150 are closed a predetermined amount of time leading up to system shut down and remain closed a predetermined amount of time following start up of the system 116a. In one exemplary embodiment, the predetermined time period may be substantially equal to zero to sixty seconds such that the control devices 136 and 150 are closed approximately zero to sixty seconds prior to the system 116a shutting down and are opened zero to sixty seconds following start up of the

system **116a**. While a fixed or straight time (i.e., zero to sixty seconds) is described, the predetermined time period may be based on performance of the system **116a** and/or the compressor **118**. Specifically, the predetermined time period could be based on the discharge line temperature or liquid level of the compressor **118**, which is indicative of the compressor and system performance.

[0156] Once the solenoid valve **150** is opened, intermediate-pressure vapor is supplied to the compressor **118** at the vapor injection port **148**. As described above, such vapor injection improves the ability of the compressor **118** to provide vapor and discharge pressure. The solenoid valve **150** may remain in the open state indefinitely to continuously provide the compressor **118** with improved performance, or the solenoid valve **150** may alternatively be selectively closed once the system **116a** reaches steady state. In one exemplary embodiment, the system **116a** reaches steady state approximately 10 minutes after the solenoid valve **150** is opened and intermediate-pressure vapor is supplied to the compressor **118**.

[0157] Determining how long the solenoid valve **150** remains in the open state, thereby providing intermediate-pressure vapor to the compressor **118**, may be based on ambient outdoor conditions. For example, if the system **116a** is running in the cooling mode, intermediate-pressure vapor will be supplied to the compressor **118** for a longer period of time at higher outdoor ambient temperatures. Conversely, when outdoor ambient temperatures are low, and the system **116a** is running in the cooling mode, less intermediate-pressure vapor may be supplied to the compressor **118**. By controlling the time in which the solenoid valve **150** remains open, the amount of intermediate-pressure vapor supplied to the compressor **118** may be controlled. Controlling the supply of intermediate-pressure vapor supplied to the compressor **118** can effectively tailor the output of the compressor **118** to match demand, which as described above, may be based on outdoor ambient temperatures.

[0158] With particular reference to FIGS. **15** and **16**, regulating operation of the solenoid valve **150** may also improve performance of a defrost cycle of any of the systems **116**, **116a**, and **116b**. While the following defrost control scheme may be used with any of the foregoing systems **116**, **116a**, and **116b**, the defrost control scheme will be described in relation to control system **116a**.

[0159] In operation, the vapor injection arrangement **50** is used to provide a defrost cycle with a capacity boost to allow the system **116a** to defrost the outdoor heat exchanger **122** when operating as an evaporator in the heating mode below freezing ambient temperatures. In operation, when a defrost condition is determined, a signal is sent to the four-way reversing valve **124** to reverse flow and direct vapor at discharge pressure to the heat exchanger **122** that is experiencing the frost condition. The vapor at discharge pressure, once disposed within the heat exchanger **122** experiencing the frost condition, changes phase from a vapor to a liquid and in so doing releases heat. Releasing heat melts the frost disposed on the heat exchanger **122** and allows the heat exchanger **122** to return an essentially frost-free condition.

[0160] During the defrost cycle, the vapor injection arrangement **50** may be used to supply the compressor **118** with intermediate-pressure vapor to improve the ability of the compressor **118** to provide vapor at discharge pressure.

Improving the ability of the compressor **118** to provide vapor at discharge pressure essentially boosts the heat capacity rejected into the heat exchanger **122** experiencing the frost condition and therefore improves the ability of the system **116a** to eliminate frost faster on the respective heat exchanger **122**.

[0161] While providing vapor at intermediate-pressure to the compressor **118** improves the ability of the system **116a** to remove frost from one of the heat exchangers **122**, control of the solenoid valve **150** helps prevent migration of liquid into the compressor **118** during reversing of the four-way reversing valve **124**. Specifically, before the four-way reversing valve **124** is switched to direct vapor at discharge pressure towards the heat exchanger **122** experiencing the frost condition, the solenoid valve **150** is closed, thereby preventing intermediate-pressure vapor from reaching the vapor injection port **148** of the compressor **118** during reversing. The four-way reversing valve **124** may be closed for a predetermined amount of time leading up to reversal of the four-way reversing valve **124**. Therefore, as flow is reversed between the heat exchangers **120**, **122**, any intermediate-pressure vapor that mixes with sub-cooled liquid refrigerant or incoming liquid refrigerant within the flash tank **10** is prevented from reaching the vapor injection port **148** of the compressor **118**. As described above, preventing such liquid injection into the compressor **118** protects the compressor **118**, and therefore improves the overall performance of the system **116a**.

[0162] The solenoid valve **150** remains closed for the predetermined time to allow the refrigerant to change flow direction within the system **116a** between the respective heat exchangers **120**, **122**. In one exemplary embodiment, the predetermined time period may be approximately equal to about zero to sixty seconds. While zero to sixty seconds is one exemplary embodiment, the predetermined time period may depend on the volume of refrigerant disposed within the system **116a** and/or the sizes of the respective heat exchangers **120**, **122** (i.e., coil size, etc.).

[0163] Following the predetermined time period, the solenoid valve **150** is opened once again to allow intermediate-pressure vapor to reach the vapor injection port **148** of the compressor **118**. As previously described, providing the compressor **118** with intermediate-pressure vapor essentially boosts the heat capacity rejected at the heat exchanger **122** experiencing frost and therefore decreases the amount of time required to fully defrost the heat exchangers **122** experiencing the frost condition.

[0164] To terminate the defrost cycle, the system **116a** reverses flow such that vapor at discharge pressure is directed away from the defrosted heat exchanger **122** and toward the indoor heat exchanger **120**. Prior to the four-way reversing valve **124** changing the direction of flow of refrigeration within the system **116a**, the solenoid valve **150** is closed again. The solenoid valve **150** is closed a predetermined time period leading to the termination of the defrost cycle to prevent liquid refrigerant from reaching the compressor **118**. As described above with regard to initiation of the defrost cycle, when the four-way reversing valve **124** changes the direction of flow of refrigerant within the system **116a**, the liquid refrigerant entering the flash tank **10** may mix with the sub-cooled liquid refrigerant and intermediate-pressure vapor disposed within the interior volume

20 of the flash tank 10 and therefore may be drawn into the compressor 118 at the vapor injection port 148, causing damage to the compressor 118. Therefore, prior to the four-way reversing valve 124 changing the direction of flow of refrigerant within the system 116a, the solenoid valve 150 is closed to prevent any liquid refrigerant from reaching the vapor injection port 148 of the compressor 118.

[0165] The solenoid valve 150 remains closed for a predetermined time period following termination of the defrost cycle. In one exemplary embodiment, the predetermined time period is approximately equal to zero to sixty seconds to allow the refrigerant within the system 116a to reach a steady state flow condition. The predetermined time period may be based on the volume of refrigerant disposed within the system 116a and/or the size of the respective heat exchangers 120, 122.

[0166] The vapor injection system 50 may also be optimized in conjunction with a variable-speed blower serving the indoor heat exchanger 120 to increase hotter supply air in heating mode and enhanced dehumidification in cooling mode (FIGS. 17 and 18). The blower speed can be varied based on the solenoid valve 150 being open or closed.

1. A flash tank comprising:
  - a shell having a middle portion disposed between a top portion and a bottom portion, said top portion, bottom portion, and middle portion cooperating to define an inner volume;
  - a first port in fluid communication with said inner volume and operable as an inlet in the heating mode and as an outlet in the cooling mode; and
  - a second port in fluid communication with said inner volume and operable as an inlet in the cooling mode and as an outlet in the heating mode.
2. The flash tank of claim 1, wherein the shell includes a height to diameter aspect ratio of approximately four to six.
3. The flash tank of claim 1, wherein said first port is formed through said middle portion of said shell.
- 4-5. (canceled)
6. The flash tank of claim 1, wherein said first port is formed tangentially to an inner surface of said shell.
7. The flash tank of claim 1, wherein said first port includes a first portion formed perpendicular to said shell and a second portion formed substantially parallel to said shell such that said first portion and said second portion cooperate to define a substantially L-shape.
8. (canceled)
9. The flash tank of claim 1, further comprising internal baffles disposed within said shell.
- 10-13. (canceled)
14. The flash tank of claim 1, wherein said second port is disposed in said bottom portion of said shell.
15. The flash tank of claim 1, further comprising a disk disposed within said shell to separate a liquid portion of the shell from a vapor portion of the shell.
- 16-21. (canceled)
22. The flash tank of claim 1, further comprising a recirculation tube formed through said middle portion of said shell to remove liquid from said shell when said liquid reaches a predetermined level within said shell.
23. (canceled)

24. The flash tank of claim 1, further comprising a sight glass formed through said shell for viewing a pre-determined fluid level within said shell.

25. The flash tank of claim 1, further comprising a liquid level sensor for determining a fluid level within said shell.

26. A heat pump system operable in a heating mode and a cooling mode comprising:

- a first heat exchanger;
  - a second heat exchanger in fluid communication with said first heat exchanger;
  - a compressor in fluid communication with each of said first and second heat exchangers; and
  - a tank in fluid communication with each of said first and second heat exchangers and said compressor, said tank including:
    - a shell having a middle portion disposed between a top portion and a bottom portion, said top portion, bottom portion, and middle portion cooperating to define an inner volume;
    - a first port receiving fluid from said first heat exchanger and in fluid communication with said inner volume, said first port operable as an inlet in the heating mode and as an outlet in the cooling mode; and
    - a second port receiving fluid from said second heat exchanger and in fluid communication with said inner volume, said second port operable as an inlet in the cooling mode and as an outlet in the heating mode.
27. The heat pump system of claim 26, further comprising a first control device disposed between said first port and said first heat exchanger.
28. The heat pump system of claim 27, wherein said first control device is one of a thermal expansion valve, an electronic expansion valve, a fixed orifice, or a single, bi-directional electronic expansion valve.
- 29-31. (canceled)
32. The heat pump system of claim 27, further comprising a check valve disposed between said first port and said first heat exchanger and operable to allow fluid to bypass said first control device in said cooling mode and direct said fluid into said first control device in said heating mode.
33. The heat pump system of claim 27, further comprising a second control device disposed between said first port and said first heat exchanger.
34. The heat pump system of claim 33, wherein said first and second control devices are selected from the group comprising: a thermal expansion valve, an electronic expansion valve, a fixed orifice, or a single, bi-directional electronic expansion valve.
- 35-36. (canceled)
37. The heat pump system of claim 33, further comprising a check valve disposed between said first port and said first heat exchanger and operable to allow fluid to bypass said second control device in said heating mode and direct said fluid into said second control device in said cooling mode.
38. The heat pump system of claim 27, further comprising a third control device disposed between said second port and said second heat exchanger.
39. The heat pump system of claim 38, wherein said first and third control devices are selected from the group com-

prising: a thermal expansion valve, an electronic expansion valve, a fixed orifice, or a single, bi-directional electronic expansion valve.

**40-41.** (canceled)

**42.** The heat pump system of claim 38, further comprising a check valve disposed between said second port and said second heat exchanger and operable to allow fluid to bypass said third control device in said cooling mode and direct said fluid into said third control device in said heating mode.

**43.** The heat pump system of claim 26, further comprising an injection line extending from said tank to said compressor.

**44.** The heat pump system of claim 43, further comprising a fourth control device disposed on said injection line to control fluid from said tank to said compressor.

**45.** (canceled)

**46.** The heat pump system of claim 44, wherein said fourth control device is a solenoid valve.

**47.** The heat pump of claim 44, wherein said fourth control device is controlled based on at least one of outdoor ambient temperature, compressor discharge temperature, indoor heat exchanger fan speed, thermostat stage demand, and a reversing valve signal.

**48-55.** (canceled)

**56.** The heat pump system of claim 38, further comprising a fifth control device disposed between said second port and said second heat exchanger.

**57.** The heat pump system of claim 56, wherein said first third, and fifth control devices are selected from the group comprising: a thermal expansion valve, an electronic expansion valve, a fixed orifice, or a single, bi-directional electronic expansion valve.

**58-59.** (canceled)

**60.** The heat pump system of claim 56, further comprising a check valve disposed between said second port and said second heat exchanger and operable to allow fluid to bypass said fifth control device in said heating mode and direct said fluid into said fifth control device in said cooling mode.

**61-92.** (canceled)

**93.** The heat pump system of claim 56, further comprising a second control device disposed between said first port and said first heat exchanger.

**94.** The heat pump system of claim 93, wherein said first, second, third, and fifth control devices are selected from the group comprising: a thermal expansion valve, an electronic expansion valve, a fixed orifice, or a single, bi-directional electronic expansion valve.

\* \* \* \* \*