

[54] **COMPACT COMBINATION INFRA-RED HEATING AND VENTILATING UNIT**

[72] Inventors: **Ronald E. Duhamel**, Middletown;
James E. Hutten, Mason, both of Ohio

[73] Assignee: **Panacon Corporation**, Cincinnati, Ohio

[22] Filed: **Dec. 23, 1970**

[21] Appl. No.: **100,868**

[52] U.S. Cl. **219/343, 98/42, 219/220, 219/352, 219/354, 240/2 V**

[51] Int. Cl. **F24h 9/02, H05b**

[58] Field of Search.....219/220, 342, 343, 347, 350, 219/351, 352, 354, 357, 361, 366, 367, 368, 377, 370; 250/88, 89; 237/46; 98/42, 43; 240/2 R, 2 V, 47, 78 H, 78 HA

[56] **References Cited**

UNITED STATES PATENTS

2,875,316	2/1959	Ford et al.	219/361 X
2,800,563	7/1951	Browne et al.	219/354 X
2,694,135	11/1954	Brockmole	219/354
3,001,056	9/1961	Spear	219/361
2,016,474	10/1935	Wood	250/88 X
3,309,502	3/1967	Witherspoon	219/367

FOREIGN PATENTS OR APPLICATIONS

524,524 5/1921 France.....250/88

Primary Examiner—William H. Beha, Jr.
Attorney—Melville, Strasser, Foster & Hoffman

[57] **ABSTRACT**

A compact, combination infra-red heating and ventilating unit for bathrooms and the like. The unit is divided into an upper compartment containing all the electrical components, and a lower compartment containing the infra-red lamps. The bulk-head dividing the said compartments is provided with an aperture for the flow of air to the ventilating fan in the upper compartment, and the aperture is shielded from back radiation from the infra-red lamps. The interior of the lower compartment and the shields are provided with heat reflective surfaces. A cover plate is provided which has apertures larger than the outside diameter of the lamps to provide for air flow, and the apertures in the cover plate have contoured edges to reflect peripheral radiation into the room. The upper compartment contains a motor and fan and all the electrical wiring, and is adapted to be connected to a duct for venting to atmosphere. A gravity actuated damper is arranged in the vent opening such that when the fan is not operating, it still permits passage of hot air by convection.

6 Claims, 4 Drawing Figures

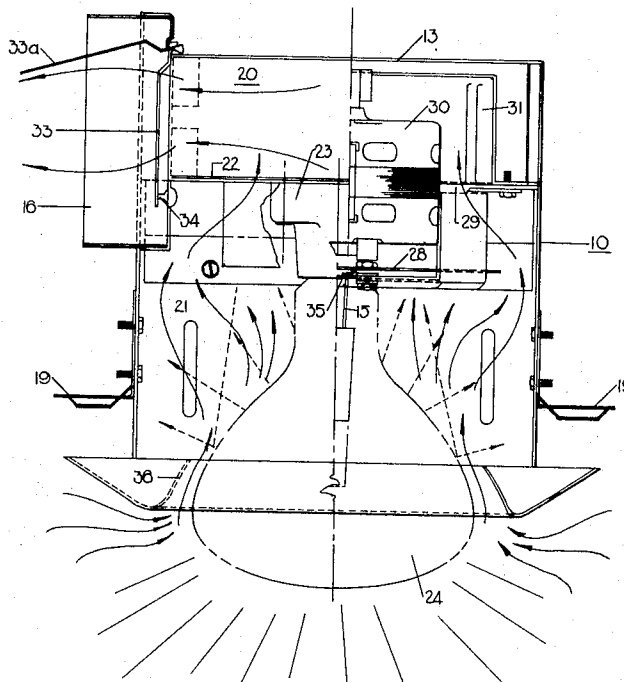

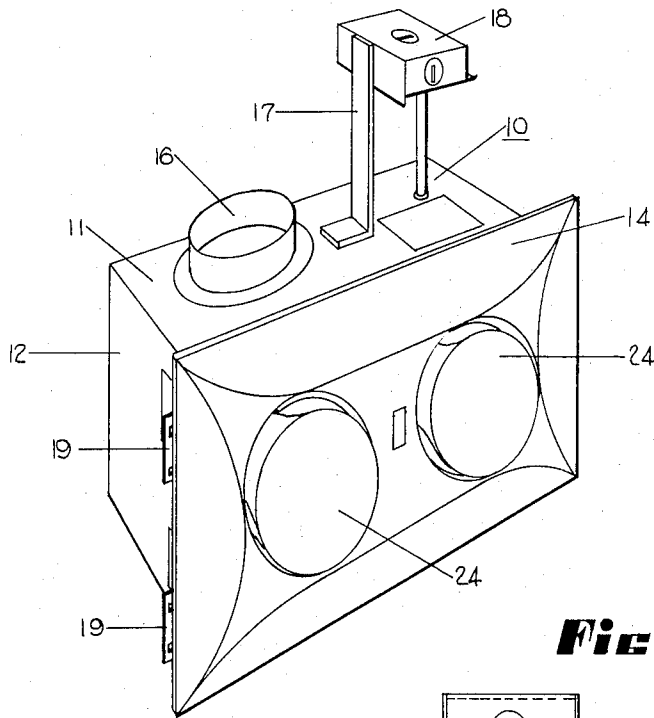

Fig 1

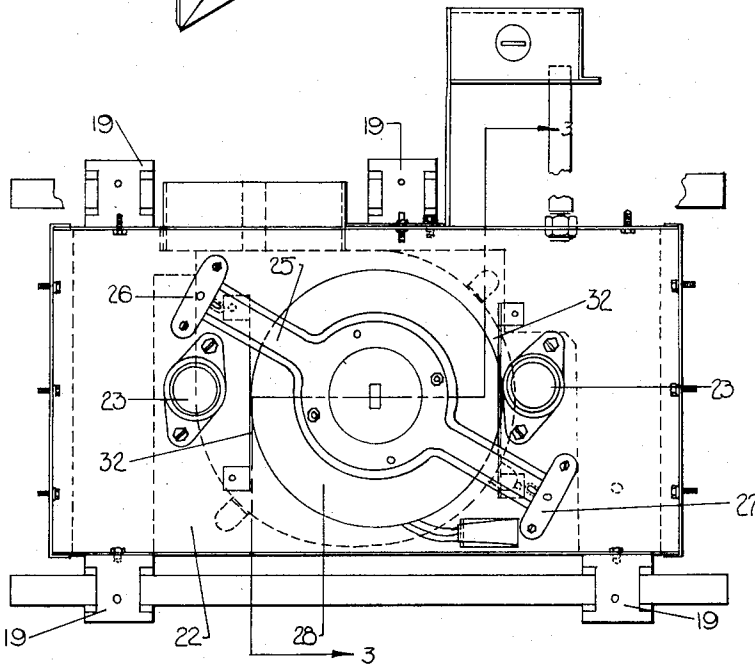

Fig 2

INVENTORS
RONALD E. DUHAMEL
JAMES E. HUTTEN

BY *Melville, Shesser, Foster and Hoffman*
ATTORNEYS

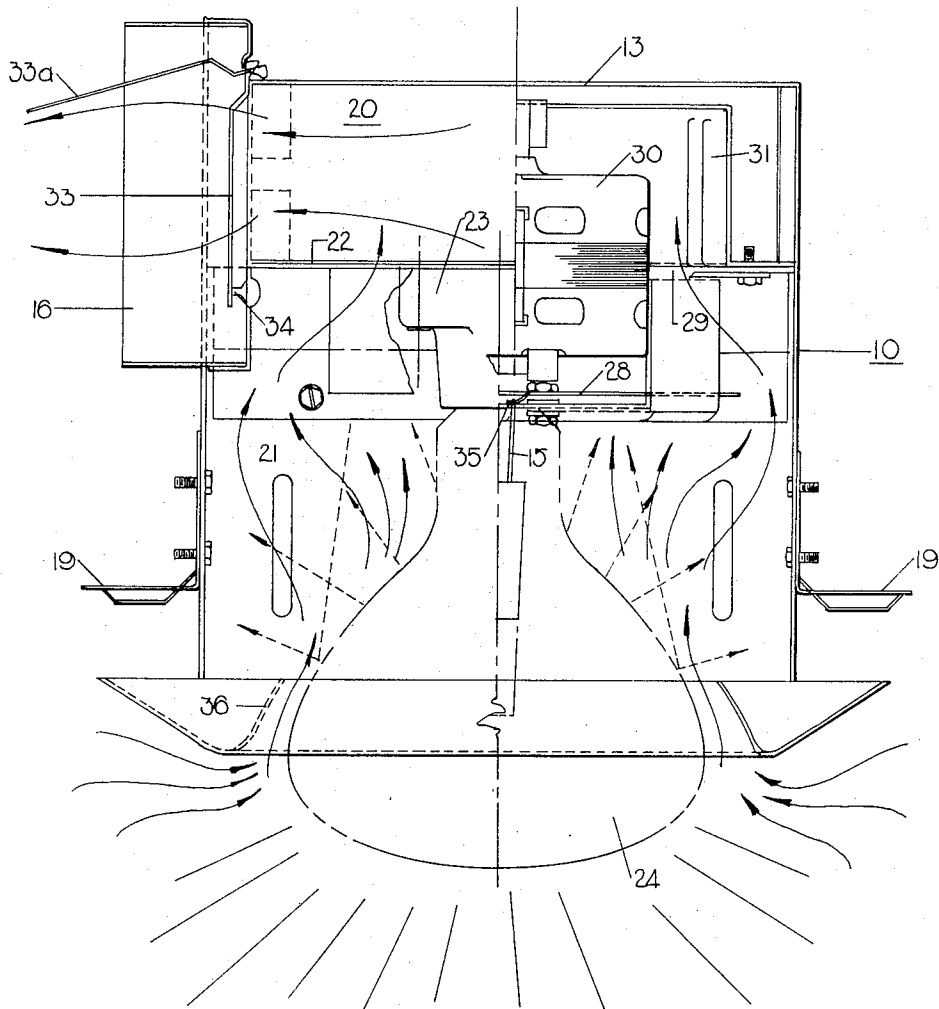

Fig 3

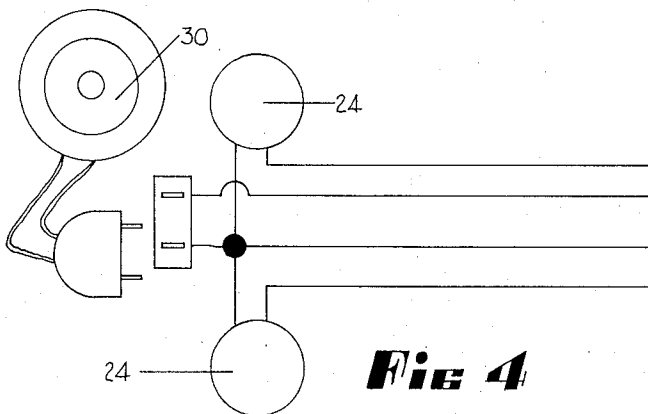

Fig 4

INVENTORS
RONALD E. DUHAMEL
JAMES E. HUTTEN

BY *Melville, Strasser, Foster and Hoffman*
ATTORNEYS

COMPACT COMBINATION INFRA-RED HEATING AND VENTILATING UNIT

BRIEF SUMMARY OF THE INVENTION

This invention relates to a prefabricated combination heating and ventilating unit which employs as the heat source multiple infra-red electric lamps that generate radiant heat by conversion of electrical energy. The combination unit of the present invention is especially suitable for installation recessed between the joists of the room ceiling, attached to and supported by the joists, with the heat-radiating lamp surfaces facing downward just below the ceiling. When installed, the unit box is concealed by an ornamental cover panel having two circular apertures slightly larger in diameter than the lamp faces, one opening for each infra-red lamp. The unit also can be mounted on a vertical or sloping side wall, if desired. Ventilation is provided by a squirrel cage type blower, powered by an electric motor enclosed within the unit box, which may be energized independently of the infra-red lamps or integrated with electrical circuit for the lamps. The air from the ventilating fan is discharged through an exhaust duct to the outside of the building.

The general purpose of this invention is to provide a combination infra-red heating and ventilating unit for ceiling installation that is compact, efficient, electrically and mechanically simple, easy to install, and electrically safe under all operating conditions.

Ancillary to the purpose of maintaining electrical safety, an important object of the invention is to arrange the assembly of the components within the unit box so that the motor and blower and the electrical wiring for the motor and lamps are separated from and shielded from the back-radiation of the heat lamps within the unit.

Another object of the invention, also directly related to the electrical safety of the installed combination unit, is to provide all interior surfaces of the unit and the shields for the motor and other electrical components with a radiant-heat-reflective enamel surfacing, to minimize the temperature rise of the air within the unit that might result in deterioration or malfunction of the motor or wiring or cause an electrical fire.

Another important object is to accomplish both the ventilation of the room and the cooling of the unit with a single motor and fan, thereby eliminating the auxiliary cooling fan and motor and its associated electrical wiring that have previously been required in similar combination units.

A special purpose of the invention is to provide the combination unit with a novel offset damper which closes automatically the orifice through which air is discharged from the fan into the exhaust duct, so that any back draft of cold air through the unit into the room when the blower fan is not operating is prevented, but superheated air within the unit may escape around the edges of the damper plate into the duct, thereby preventing excessive temperature build-up within the unit.

A further purpose is to provide the unit with a reflective metal cover panel for the ceiling installation of the unit, having circular apertures through which the infra-red lamp faces project, these openings being larger in diameter than the lamps to provide an annular air space through which the ventilating air can flow into and

through the unit to the fan intake, the sides of the apertures being contoured so as to reflect outwardly the radiant heat from the adjacent peripheral rim of the infra-red lamp.

BACKGROUND OF THE INVENTION

The earliest and simplest method of using an infra-red lamp to provide heat in a small room was simply to screw the lamp into a standard electric lamp socket mounted on the ceiling. The lamp then produced radiant heat, but was exposed to possible breakage and due to its high surface temperature might cause a painful burn if touched. The next step was to encase a single lamp in a small rectangular box having a cover plate with a circular opening in which the face of the infra-red lamp was exposed; this unit was then installed within the ceiling structure in the same way as a ceiling-recessed lighting fixture. A single lamp unit of this kind may be used either as a lighting fixture or an infra-red radiant ceiling heater and does not require a cooling fan for electrical safety nor does it provide any ventilation of the room space. Two-lamp ceiling fixtures of similar construction have also been produced; this type enables the use of a light bulb in one lamp socket and an infra-red radiant heat lamp in the other.

Infra-red radiant ceiling heaters with multiple lamps (two or three) have been produced and these also are installed as ceiling-recessed fixtures. Such multiple units produce more heat build-up within the unit box than a single lamp heater and for electrical safety must be provided with a small electric powered cooling fan inside the unit box. Since the purpose of the fan is merely to disperse the heated air inside the unit so as to maintain safe internal temperatures when the lamps are in operation, this type of unit does not require a duct discharging the air outside the building, nor does it provide any ventilation of the room. If the fan motor fails while the lamps are operating the unit overheats and becomes unsafe, therefore the electrical circuitry for the lamps and motor are integrated so that the motor operates when the lamps are energized, but if the motor fails the lamps are shut off.

The combination unit, which provides both infra-red radiant heat and air ventilation to the room in which it is installed, is a recent development in this field; the present invention is concerned with an improved and simplified combination unit of this type. When a ventilating fan is added to the infra-red heating unit it then becomes a ventilating unit and Building Code regulations provide that the fan exhaust air must be discharged into a duct to the outside of the building. Prior to the present invention, such combination units have incorporated two electric powered fans: (1) a "large" squirrel cage fan for ventilation having a capacity of about 50 CFM and (2) a "small" fan within the unit box for cooling the infra-red lamps. Usually the ventilating fan is mounted on the outside of the unit box, with its motor inside the box so that the motors of both fans and all their electrical wiring are directly exposed to back-radiation from the infra-red heat lamps. Because the ventilating fan and the lamps can be used separately, the infra-red heat lamps may often be energized when the ventilating fan is not operating, therefore it is necessary that the cooling fan be included in the lamp circuit so that it operates continuously while

the lamps are on, otherwise excessively high internal temperatures will result and create an electrical safety hazard.

Examination and comparative analysis of the design features and the structural arrangements of the components in various combination infra-red heating-ventilating units that are now commercially available made it clearly evident that improvement is needed and particularly, to eliminate the auxiliary "cooling" fan. When it is made possible to accomplish both infra-red heating and ventilating by a unit having a single motor and fan, this enables making it more compact, simpler mechanically and less complicated electrically, more efficient, less subject to possible malfunction, more durable so as to provide a longer service life, possessing complete electrical safety, and at a lower cost.

The improved combination unit herein disclosed has been found particularly suitable for heating and ventilating small rooms such as bathrooms and bath-dressing rooms, to provide personal comfort for the occupants and to ventilate the air and remove excessive moisture. It is also effective as a supplemental heat source in motel rooms, mobile homes and small apartments, particularly in the spring and fall when the main heating system may not be in operation. For rooms of greater area, multiple units may, of course, be installed. An important advantage of the infra-red heating unit is that it provides almost instantaneous radiant heat when the unit is turned on, with none of the delay that is typical of air convection heating systems.

BRIEF DESCRIPTION OF THE DRAWINGS

FIG. 1 is a general perspective view of the complete unit, showing the unit box with its attachment brackets, exhaust duct fitting, electrical junction box, cover panel and the infra-red lamps in place.

FIG. 2 is a detail bottom plan view of the unit box, showing the locations of the motor mounting bracket, lamp sockets, air guide to the exhaust opening, radiant heat shield between the motor base and the infra-red lamps, and the radiant heat reflector vanes between the motor base and the lamp sockets.

FIG. 3 is a schematic cross sectional view, taken on the line 3—3 of FIG. 2, of the complete unit under actual operating conditions, showing the locations of the motor, blower wheel, air guide to exhaust, exhaust damper, lamp socket and lamp, radiant heat-reflective shields between the motor base and lamps, the bulkhead separating the lamps from the electrical wiring and fan; and particularly, the air flow pattern around the lamps, around the motor shields, into the air guide channel and to the exhaust orifice.

FIG. 4 is a schematic representation of the electrical wiring diagram for the two-lamp infra-red heating and ventilating combination unit of the Typical Example of this invention.

DETAILED DESCRIPTION OF THE INVENTION

The infra-red radiant heat lamp is designed to project most of the radiant heat that it produces outwardly from the face and adjacent rim areas of the lamp. However, this lamp also radiates a great deal of heat from the body and stem of the bulb which is inside the unit box. The heat thus radiated is termed, for the purposes of this disclosure, "back radiation", and it is this back

radiation which creates the problem of overheating of the combination unit when the ventilating fan is not operating. Under such conditions the glass of the body and stem of the lamp becomes extremely hot. It has been determined that when two infra-red radiant lamps are operated continuously in a closed space without ventilation, the surface temperature of the glass body may rise as high as 470° F.

Several means are disclosed herein by which the objectionable temperature rise from the back radiation of the lamps can be prevented or minimized so that a combination unit having a single motor and fan can be made electrically safe and reliable. These novel means vary in effectiveness; therefore in the preferred constructions of the unit two or more are used conjointly, although each of them if used independently contributes much improved performance in respect to temperature control. Stated briefly, these are:

- A. Separation of the fan motor and the electrical wiring for the motor and lamps, within the interior space of the unit, from the radiant heat source (the infra-red lamps) by a radiant-heat-reflective sheet metal bulkhead and heat radiation shields, these constituting a heat-protected compartment for the electrical components in the upper part of the box.
- B. Arrangement and design of the components in the lamp compartment (lower part of the unit box) to reflect radiant heat outwardly from all interior surfaces, including the motor shield and reflectors, and from the periphery of the infra-red lamp face.
- C. Provision of an automatic, offset damper, integral with the fan exhaust orifice of the unit, that closes by gravity when the ventilating fan is not operating, but provides a spaced opening around its edges that enables superheated air to escape into the exhaust duct when the damper is closed.

As best seen in FIG. 1, the unit is enclosed in a housing 10 of sheet metal. The housing 10 (with its bottom facing the viewer in the Figure) has a top wall and side walls 11 and end walls 12. The top wall is indicated at 13 in FIG. 3. The cover element 14 is separate and is attached to the casing by means of spring 15 (FIG. 3).

One of the side walls 11 is provided with a fitting 16 for attachment to a duct venting to the atmosphere. A bracket 17 carries the junction box 18 for electrical connection of the unit. Mounting brackets 19 are provided for mounting the unit to the joists.

Basically, the housing 10 is divided into upper and lower compartments. The upper compartment is indicated generally at 20 and the lower compartment at 21. The dividing wall is in the form of a sheet of metal 22 which carries the socket 23 for the heat lamps 24. The bulkhead 22 also mounts the motor bracket 25 as at 26 and 27 and secured to the bracket 25 is a circular plate 28. Coaxially with respect to the circular plate 28 is a circular aperture 29 in the bulkhead 22. The electric motor 30 is mounted on the bracket 25 above the circular plate 28 and the motor 30 drives the ventilating fan 31 which is coaxial therewith.

Adjacent the aperture 29 in the bulkhead 22 there are provided the sheet metal vanes 32 which protect the aperture 29 from direct back radiation from the base portions of the heat lamps 24. The plate 28 similarly shields the compartment 20 from back radiation.

A damper is provided in the exhaust fitting 16 and is indicated at 33 in its closed position and 33a in its open position. The damper 33 is hinged at the top and closes by gravity against an abutment or stop 34. Under the influence of exhaust air when the fan is operating, the damper moves to the position 33a to permit air to flow out to the exhaust duct. When the fan is not operating, the damper does not close the opening entirely by virtue of the stop 34. There is always a space around the periphery of the orifice which preferably amounts from about 25 percent to about 50 percent of the full opening of the orifice. The purpose of this structure is to permit superheated air to pass out to the exhaust duct when the lamps are operating and the exhaust fan is not operating.

The cover plate 14 which is exposed in the room in which the unit is installed, may be decorative in character. It is of sheet metal and as indicated above is attached by means of a spring which hooks on to a hook 35 which may be struck out from the plate 28. The cover plate 14 has apertures for the heat lamp 24 which are larger than the diameter of the heat lamp so as to allow an annular space around the edges of the heat lamp for passage of air to the ventilating fan. As best seen in FIG. 3, the edges of these orifices are configured as at 36 for a purpose to be described hereinafter.

From the detailed description above given, it will be seen how the three means described above may be applied to a unit of this character. As to the means indicated above as A, it will be seen that the interior space of the housing has been separated into the lamps compartment 21 and the motor and wiring and fan compartment 20. The circular sheet metal heat radiation shield 28 between the motor mount and the motor and the vanes 32 between the lamps and the motor shield the motor compartment from the aforementioned back radiation. In this way, the top and upper sides of the unit together with the bulkhead, the motor shield, and the reflector vanes constitute the heat protected motor compartment 20. It will be understood that the separate motor shield and reflector vanes could be combined into a single piece if though to be desirable.

From the foregoing description, it will be understood how back radiated heat from the lower body and stem of the infra-red lamps impinges on the interior surfaces of the lamp compartment to produce elevated temperatures of the air and the box walls and the components when the ventilating fan is not operating. The application of the means identified as B and described above involves the provision for all the interior surfaces of the lamp compartment, including the walls, the bulkhead, the motor shield and the reflectors, of a highly heat-reflective surface, preferably white enamel. Alternatively, the radiant heat-reflective surfaces may be of bright plated non-corrodible metal or metal foil. In this way the back radiated heat is reflected outwardly and downwardly away from the bulkhead and motor compartment which minimizes the temperature rise within the unit. It also increases the heating efficiency of the unit since a greater part of the total heat produced enters the room space instead of being wasted by overheating the unit box and its components.

The outward reflection of the back radiated heat is further enhanced by forming the bulkhead with an angular heat reflecting panel of about 45° inclination at each end where it is attached to the walls of the unit box. This is the preferred construction for maximum efficiency of temperature control. Additionally, the configuration of the cover panel described above constitutes an additional means by which back radiation is reflected outwardly. The cover panel may be of sheet metal having a heat reflective surface finish such as white enamelled steel, but it is preferably of polished aluminum.

FIG. 3 also illustrates the application of the third means C. The rectangular exhaust orifice from the fan discharge into the sleeve of the duct fitting is covered by the flat damper plate as previously described. The offset mounting provides a free opening along the sides and lower edge of the damper plate through which the superheated air which may accumulate within the housing when the fan is not operating can escape into the exhaust duct and thereby prevent excessive heat build up.

The purpose of a damper in this type of unit is to prevent a back draft blast of cold air from outside the building entering the room when the heating unit is operating but the ventilating fan is not. The offset damper described herein accomplishes this purpose but still permits superheated air to escape. The objects of this damper could be accomplished by various means and the particular offset damper is shown by way of example. It will be understood that the edges of the opening might be provided with serrated metal projections to determine the offset distance instead of the single bumper stop or small apertures could be made in the damper plate to permit the escape of superheated air.

TYPICAL EXAMPLE OF A PREFERRED EMBODIMENT

FIG. 1 shows the complete two-lamp combination unit, in perspective view, and FIG. 2 is a detailed plan view from the lower (lamp compartment) side. It can be seen that the unit is very compact and that the only components outside the box are the mounting brackets, the exhaust fitting sleeve, the electrical junction box and the wiring raceway. The unit box dimensions of the Typical Example are: 7½ inches × 7¾ inches × 14¼ inches overall. Due to its small dimensions the unit may be installed either parallel to or across the joist direction of a ceiling with standard 16 inch joist spacing.

INSTALLATION - All four sides of the unit box are provided with vertical slots for attachment of the mounting brackets, so that the unit can be placed either parallel to or across the joist direction. The mounting brackets are adjustable vertically to allow for variations in the ceiling thickness. Flat support bars are inserted through the brackets and then nailed to the joists. Spacing of the unit from any vertical wall surface should be at least 12 inches.

INFRA-RED LAMPS - The infra-red heat lamps used are standard 250 watt-R40 type, for operation with 120 volt, 60 Hz electric current. Two lamps therefore consume about 500 watts and provide about 1700 BTU of radiant heat.

VENTILATING FAN AND MOTOR - The fan is a "squirrel cage" blower wheel, 5 3/16 inches diameter and 1 3/4 inches high, powered by a 120 volt, 0.90 Amp., 60 Hz, 1550 RPM, thermal protected motor. In continuous operation, the fan consumes about 55 watts and has a rated air delivery of about 60 CFM. The total electrical load for the unit with two lamps and the fan operating continuously is about 560 watts.

COVER PANEL - The cover panel is of formed, polished sheet aluminum, 9 7/8 inches × 16 7/8 inches overall, with two apertures each 5 inches in diameter. The walls of the apertures are contoured outwardly to a diameter of about 6 7/8 inches and a height of 7/8 inch. The base diameter of the aperture provides an annular opening of about 5/16 inch width around the rim of the infra-red lamp through which the fan draws its intake air from the room. The cover panel is held in place over the ceiling recess by a tension spring at its center point, attached at its other end to the motor mount bracket inside the lamp compartment of the unit. This enables the panel to be adjusted laterally so that each lamp is properly centered in its aperture, to ensure uniform air flow around the lamps to the fan intake.

ELECTRICAL CIRCUITRY - The combination unit is internally pre-wired as shown in the schematic wiring diagram of FIG. 4. The motor terminals are wired to a parallel blade, snap-in type connector. The internal leads of the wiring are carried through a plated steel tubing raceway to the junction box for field splicing to the house circuit.

This combination unit offers numerous optional conditions of operation which are provided by wiring to one, two or three standard off-on wall switches. With a single switch, both lamps and the fan operate simultaneously. Two switches enable operating the fan and the lamps separately. With three switches the options are: 1 lamp; 2 lamps; 1 lamp and fan; 2 lamps and fan; fan only. Or one infra-red lamp may be replaced by an incandescent light bulb for more light. If desired, a timer switch may be used to energize or de-energize the heat lamps at a predetermined time.

UNDERWRITERS' LABORATORIES, INC. LISTING - The combination heating-ventilating unit of the Typical Example, above described, has been tested and meets all the requirements of Underwriters' Laboratories, Inc. for the components and their assembly in the complete unit in respect to electrical safety and performance reliability, under their "Standard for Electric Space Heating Equipment", UL 573-1968. These tests included: measurement of power input, temperature rise with the ventilating fan not operating, dielectric withstand, over-voltage, and motor locked-rotor tests. The combination infra-red radiant heating and ventilating unit having the novel features herein disclosed has been listed by U.L. under the above-identified Standard.

The invention having now been fully disclosed and its novel features set forth in detail, it is evident that numerous variations and combinations can be made as to the shape and dimensions of the combination heating-ventilating unit and the arrangement of the components, therefore no limitations are intended except those defined by the following claims.

The embodiments of the invention in which an exclusive property or privilege is claimed are defined as follows:

1. A compact, combination infra-red heating and ventilating unit, including an electric motor driven ventilating fan, a discharge orifice and means for attachment to an exhaust duct, and at least two infra-red radiant heat lamps, all contained in a sheet metal housing having a top and sides, and being open at the bottom; said discharge orifice having a gravity actuated flat damper plate covering said orifice when said fan is not operating and discharging air therethrough, said damper plate being hinged at the top edge and offset by a fixed distance from the face of said orifice to provide open spaces at the edges of said orifice through which superheated air inside the housing can escape into the exhaust duct when said ventilating fan is not operating, the total area of said spaces being in the range of about 25 percent to about 50 percent of the area of said discharge orifice, whereby heat build-up within said housing is minimized.

2. A prefabricated combination infra-red heating and ventilating unit, including an electric motor driven ventilating fan, a discharge orifice and means for attachment to an exhaust duct, and at least two infra-red radiant heat lamps, all contained in a sheet metal housing having a top and sides, and being open at the bottom; said fan, motor, and the electrical wiring for the heat lamps and motor being disposed in the upper portion of said housing, and said heat lamps being disposed in the lower portion of said housing with their heat-radiating faces directed downwardly, and means behind the bases of said lamps provided with a highly heat-reflective surface finish to reflect the back radiation of said lamps outwardly and downwardly away from said fan, motor, and the electrical wiring of the motor and heat lamps, said unit also having a sheet metal cover panel for the open bottom of said housing, said panel having an aperture for each of said heat lamps, each of said apertures being larger in diameter than the outside diameter of the respective heat lamp faces to permit passage of air to said fan, the edges of said lamp apertures being provided with an annular downward and outward flare to provide a heat-reflective contoured surface from which peripheral lateral heat radiation from said lamps is reflected outwardly from said unit.

3. A prefabricated combination infra-red heating and ventilating unit, including an electric motor driven ventilating fan, a discharge orifice and means for attachment to an exhaust duct, and at least two infra-red radiant heat lamps, all contained in a sheet metal housing having a top and sides, and being open at the bottom; a bulkhead dividing said housing into upper and lower compartments, an aperture in said bulkhead for the passage of air, said fan, motor, and the electrical wiring for the heat lamps and motor being disposed in said upper compartment, and said heat lamps being disposed in said lower compartment with their heat-radiating faces directed downwardly, a sheet metal shield in front of said aperture, and sheet metal vanes adjacent said aperture between said aperture and said heat lamps, said bulkhead, shield and vanes in combination with the top and upper sides of said housing constituting a heat-protected upper compartment for said motor and electrical wiring; said discharge orifice being provided with a gravity actuated flat damper plate covering said orifice when said fan is not operating and discharging air therethrough, said damper plate

being hinged at the top edge and offset by a fixed distance from the face of said orifice to provide open spaces at the edges of said orifice through which superheated air inside the housing can escape into the exhaust duct when said ventilating fan is not operating, the total area of said spaces being in the range of about 25 percent to about 50 percent of the area of said discharge orifice, whereby heat build-up within said housing is minimized when said heat lamps are energized but said ventilating fan is not operating.

4. A prefabricated combination infra-red heating and ventilating unit, including an electric motor driven ventilating fan, a discharge orifice and means for attachment to an exhaust duct, and at least two infra-red radiant heat lamps, all contained in a sheet metal housing having a top and sides, and being open at the bottom; said fan, motor, and the electrical wiring for the heat lamps and motor being disposed in the upper portion of said housing, and said heat lamps being disposed in the lower portion of said housing with their heat-radiating faces directed downwardly, and means behind the bases of said lamps provided with a highly heat-reflective surface finish to reflect the back radiation from said lamps outwardly and downwardly away from said fan, motor, and the electrical wiring of the motor and heat lamps; said discharge orifice being provided with a gravity actuated flat damper plate covering said orifice when said fan is not operating and discharging air therethrough, said damper plate being hinged at the top edge and offset by a fixed distance from the face of said orifice to provide open spaces at the edges of said orifice through which superheated air inside the housing can escape into the exhaust duct when said fan is not operating, the total area of said spaces being in the range of about 25 percent to about 50 percent of the area of said discharge orifice, whereby heat build-up within said housing is minimized when said heat lamps are energized but said ventilating fan is not operating.

5. A prefabricated combination infra-red heating and ventilating unit for ceiling recessed installation, including an electric motor driven ventilating fan, a discharge orifice and means for attachment to an exhaust duct,

5
10
15
20
25
30
35

and at least two infra-red radiant heat lamps, all contained in a sheet metal housing having a top and sides, and being open at the bottom; a bulkhead dividing said housing into upper and lower compartments, an aperture in said bulkhead for the passage of air, said fan, motor, and the electrical wiring for the heat lamps and motor being disposed in said upper compartment, and said heat lamps being disposed in said lower compartment with their heat-radiating faces directed downwardly, a sheet metal shield in front of said aperture, and sheet metal vanes adjacent said aperture between said aperture and said heat lamps, said bulkhead, shield and vanes in combination with the top and upper sides of said housing constituting a heat-protected upper compartment for said motor and electrical wiring, whereby excessive heat build-up within said unit, when said heat lamps are energized but said ventilating fan is not operating, is prevented, all interior surfaces of said lower compartment, including said bulkhead, shield and vanes, being provided with a highly heat-reflective surface finish, whereby radiant heat from the bodies of said heat lamps is reflected outwardly and downwardly away from said upper compartment, said discharge orifice being provided with a gravity actuated flat damper plate covering said orifice when said fan is not operating and discharging air therethrough, said damper plate being hinged at the top edge and offset by a fixed distance from the face of said orifice to provide open spaces at the edges of said orifice through which superheated air inside the housing can escape into the exhaust duct when said ventilating fan is not operating, the total area of said spaces being in the range of about 25 percent to about 50 percent of the area of said discharge orifice, whereby heat build-up within said housing is minimized.

6. The structure of claim 5 having two 250 watt, 120 volt heat lamps, vertically adjustable mounting brackets, a 120 volt, 1550 RPM motor and fan having a rated air delivery of 60 CFm, a spring held, laterally adjustable cover panel, and having electric circuitry for the lamps and motor to provide selective operation of the fan and lamps independently or conjointly.

* * * * *

45

50

55

60

65