

Fig. 1.

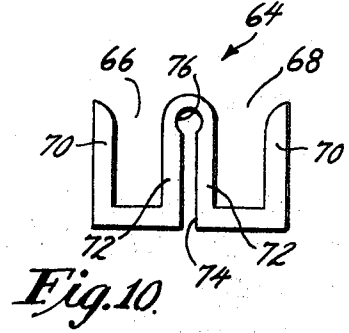

Fig. 10.

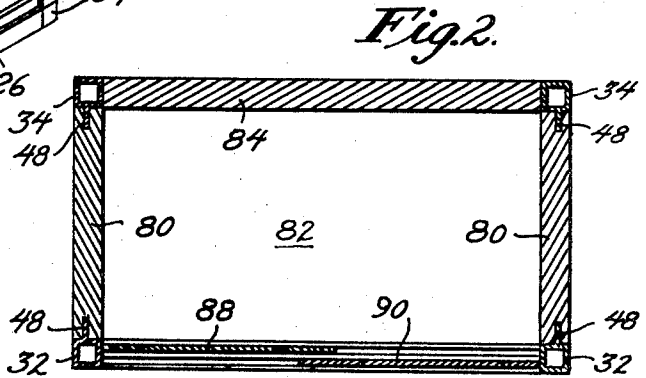

Fig. 2.

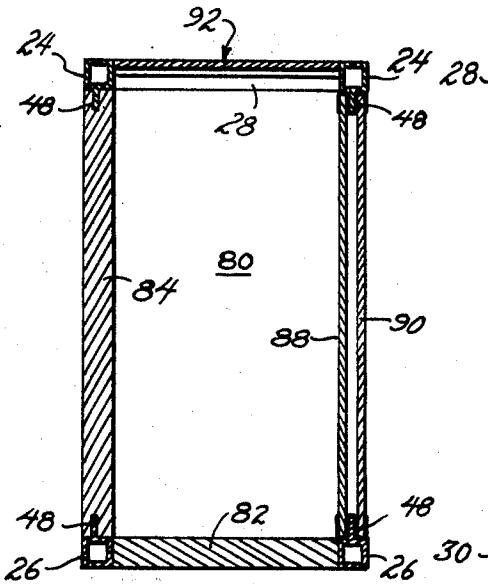

Fig. 4.

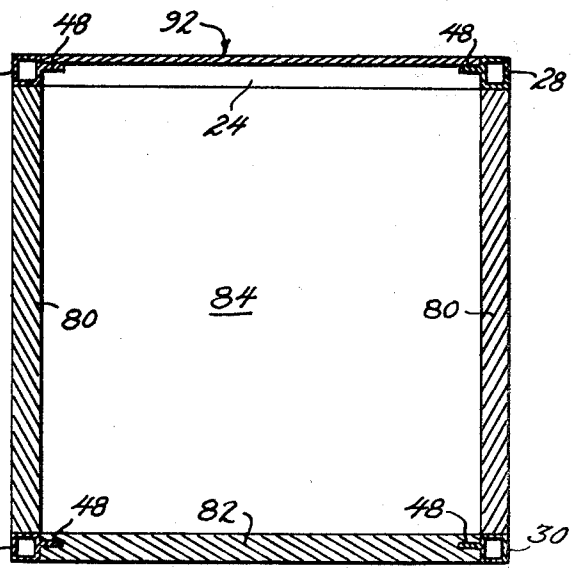

Fig. 3.

INVENTORS:
 MILTON T. BROWN
 ZDENEK BILEK
 BY
Seidel, Gonda & Goldhammer
 ATTORNEYS.

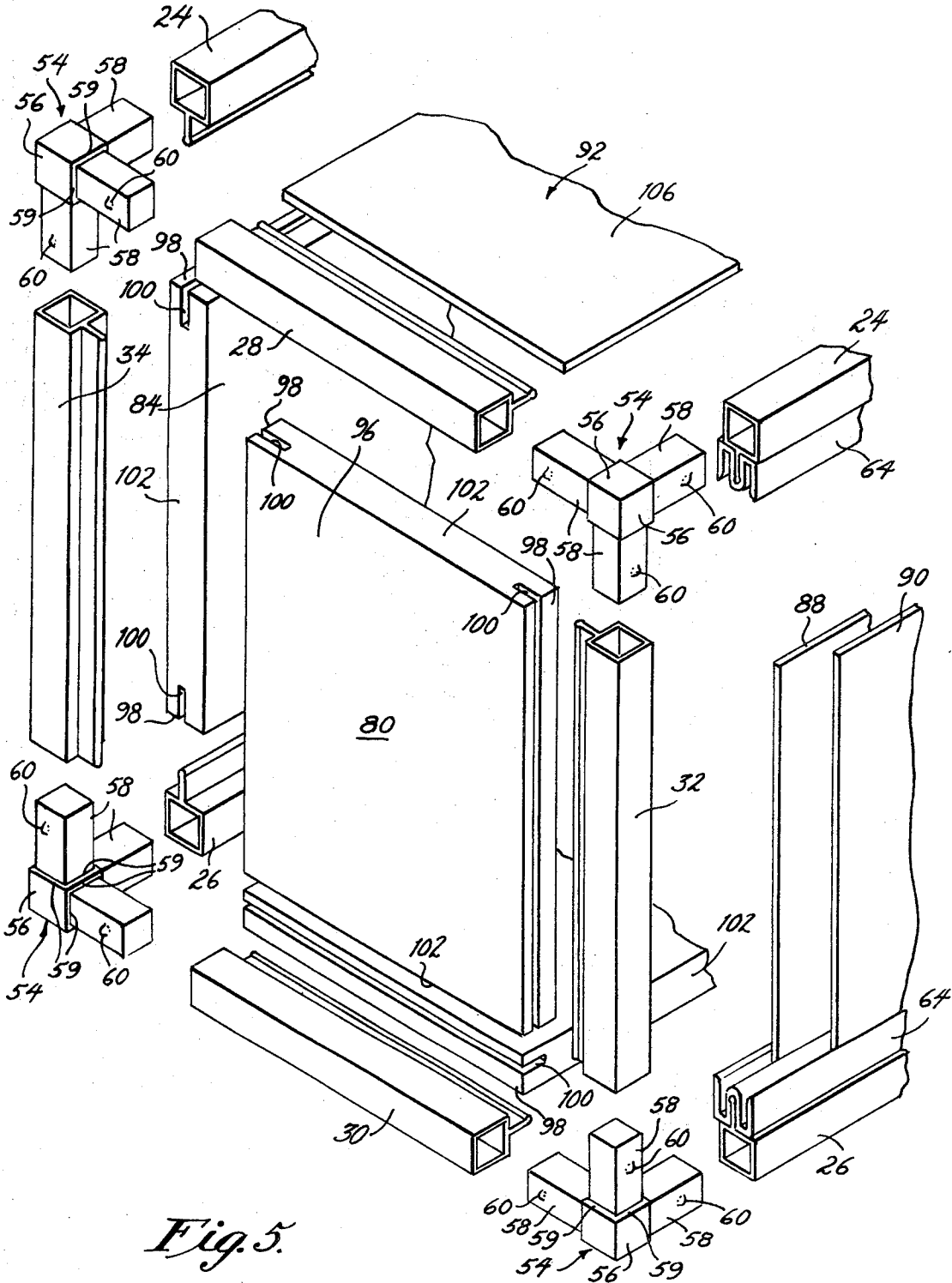

Fig. 5.

INVENTORS
MILTON T. BROWN
ZDENEK BILEK
BY
Siedel, Gonda & Goldhammer,
ATTORNEYS

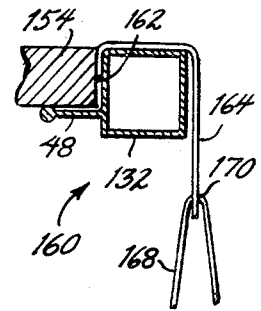
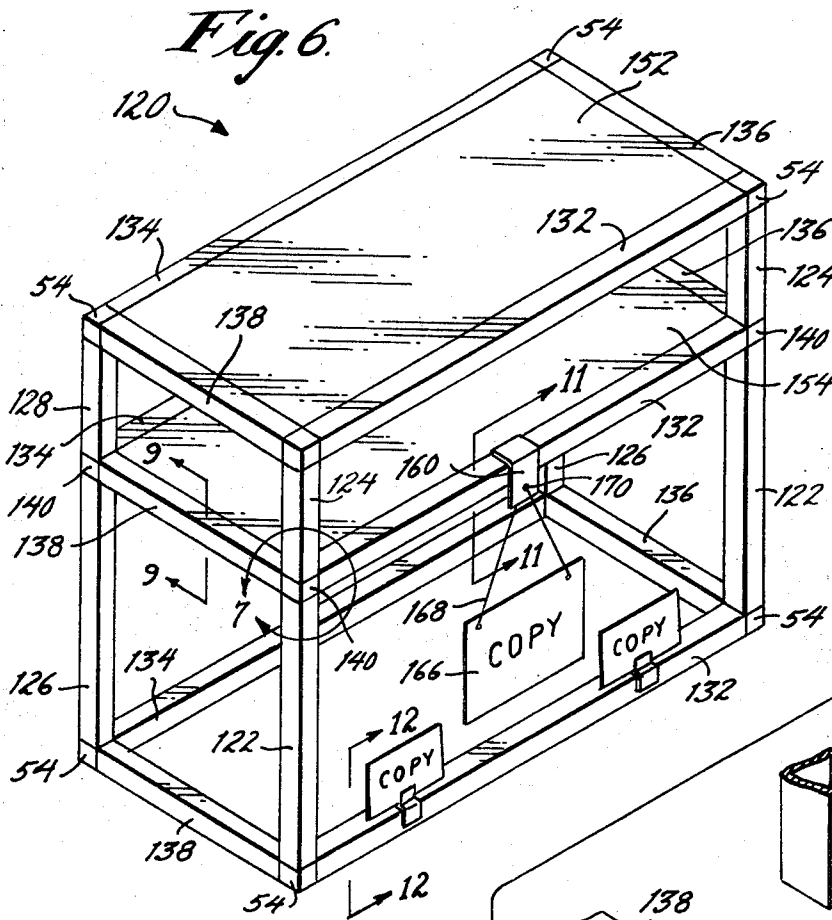

Fig. 11.

Fig. 7.

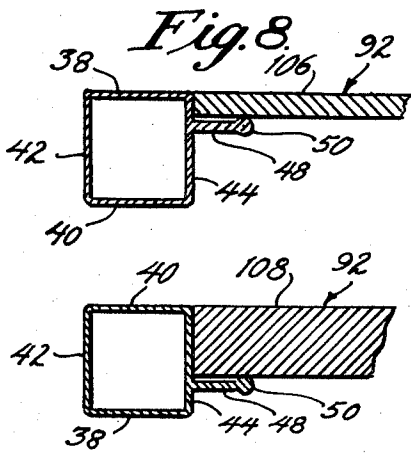
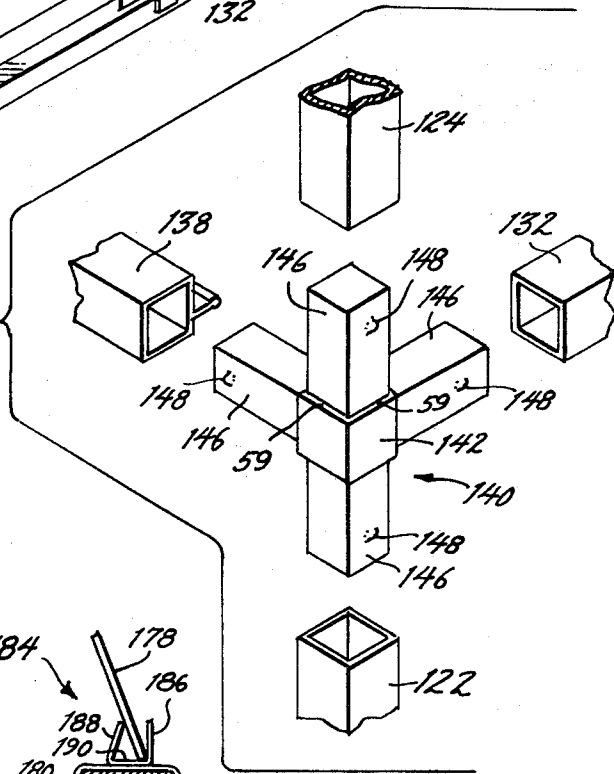

Fig. 9.

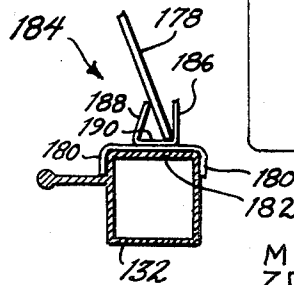

Fig. 12.

INVENTORS:
 MILTON T. BROWN
 ZDENEK BILEK
 BY
Seidel, Gonda & Goldhammer
 ATTORNEYS.

MODULAR DISPLAY ASSEMBLY

This invention relates to a display assembly and more particularly to a display assembly which can be assembled from modular units to form an assembly of desired configuration.

In businesses where it is necessary to display the merchandise, it is desirable to have display units comprising both shelves and cabinets which can be easily arranged in a desired configuration with a minimum amount of work on the part of the assembler.

Preferably a modular assembly which can be assembled without any tools or fasteners by relatively unskilled persons should be used. Additionally, such an assembly should be easy to assemble or disassemble and should be able to grow either vertically, horizontally or laterally to meet changing conditions.

Accordingly, it is an object of this invention to provide a new and unobvious modular display assembly.

It is another object of this invention to provide a modular display assembly which can be assembled and disassembled by relatively unskilled persons.

It is still a further object of this invention to provide a modular display assembly which can be assembled and disassembled without tools or fasteners.

Generally the invention relates to a modular component which is an elongated member having a plurality of sides with an elongated outwardly directed tab supported on one of the sides. The tab divides the side into two unequal portions.

Another aspect of the invention relates to a track member comprising two elongated tracks disposed in side by side spaced parallel relation with a recess disposed between the tracks and facing oppositely thereof. The tracks can be utilized to receive sliding doors.

Still another aspect of the invention relates to a connector having a core with at least two legs extending from it so that the junctures of the legs and the core define ledges that are substantially as wide as the walls of an elongated member to be connected thereto are thick.

Finally, the invention relates to a cabinet whose borders are defined by a plurality of elongated members connected together at their ends by joints. The elongated members have outwardly directed tabs. A plurality of panels are supported between some of the elongated members. Other elongated members support track members. Sliding panels are supported for sliding movement on the track members.

Other objects and advantages of the invention will be apparent from a detailed description thereof which follows wherein:

FIG. 1 is a perspective view of a cabinet constructed in accordance with a presently preferred form of the invention.

FIG. 2 is a sectional view taken along line 2—2 of FIG. 1.

FIG. 3 is a sectional view taken along line 3—3 of FIG. 1.

FIG. 4 is a sectional view taken along line 4—4 of FIG. 1.

FIG. 5 is an exploded perspective view of a portion of the cabinet illustrated in FIG. 1.

FIG. 6 is a perspective view of a modified display assembly constructed with the modular elements of the subject invention.

FIG. 7 is an exploded perspective view of one of the joint members in the assembly illustrated in FIG. 6.

FIGS. 8 and 9 show how the elongated members may support either thick or thin shelves.

FIG. 10 is an end view of a modular track member.

FIG. 11 is a hanging support for use with the modular assembly.

FIG. 12 is another form of support for use with the modular assembly.

Referring now to FIG. 1, a cabinet 20 constructed from the modular units to be described herein is shown.

The cabinet is constructed from a plurality of elongated members defining bars 24, 26, 28, 30 and columns 32, and 34.

Preferably all of the elongated members are hollow and square in cross section. However the modular display assembly could also be constructed from elongated members of other cross sections. However the square cross section is preferred since it permits the construction of assemblies with square edges and permits flat surfaces to be formed.

The cross section of a typical elongated member such as bar 28 can best be seen in FIGS. 8 and 9. Bar 28 has flat upper and lower surfaces 38 and 40 and side surfaces 42 and 44.

One of the side surfaces supports a tab 48. The tab may be an elongated substantially flat member that rests on one of its edges and projects outwardly from the side surface. The tab 48 may be continuous along the side surface, however, as will be apparent, tabs 48 may be positioned at intervals along the side surface.

The free end of the tab 48 has an enlarged bulbous portion 50, the width of which is greater than the thickness of the tab. Bulbous portion 50 promotes the rigidity of tab and also functions as a locking member as will be explained herein.

Significantly, tab 48 is not centrally disposed between sides 38 and 40 but is set closer to one side such as 38 than the other.

Adjacent elongated members may be connected at the corners of the cabinet by corner joints 54.

As seen in FIG. 5 each of the corner joints 54 comprises a core 56 shaped like a cube. The core 56 may support a plurality of mutually perpendicular legs 58 on mutually perpendicular surfaces of the cube.

Each of the legs 58 has a cross section that is similar to the interior cross section of the elongated members. In a preferred form of the invention the legs 58 are square in cross section so that they can be received within the hollow elongated members. Thus it should be observed that the elongated members need only be hollow at their ends to receive legs 58.

Each of the legs 58 is provided with a projection 60 so that it will engage the interior of the respective elongated member in a tight friction fit without the use of mechanical fasteners.

The legs 58 have a relatively small cross section with respect to the faces of core 56 so that ledges 59 are defined at the juncture of each leg 58 and its face. The ledges 59 are as substantially wide as the walls of the elongated members are thick so that a substantially continuous surface comprised of the outer surface of those members and the faces of the core is presented.

Track members 64 (FIGS. 5 and 10) are provided with sliding doors on cabinet 20. Each track member comprises two spaced mutually elongated parallel tracks 66 and 68. Preferably, the track member is com-

prised of molded or extruded polycarbonate or any other suitable rigid material. Each of the tracks 66 and 68 is defined by an outer wall 70 and an inner wall 72. The inner walls define an elongated recess 74 therebetween which has an enlarged elongated cavity 76 at its end.

Each of the modular elements, the columns, bars, corner joints 54 and track members 64, can be assembled in an interesting and unusual variety of ways in order to create display assemblies similar to those illustrated in FIGS. 1 or 6.

In FIG. 1, cabinet 20 is comprised of elongated members as explained above. However the space between adjacent members is filled by panels and sliding doors.

Typically, the cabinet may be comprised of side panels 80, a bottom panel 82 and a rear panel 84. Instead of a front panel, sliding doors 88 and 90 may be utilized, thereby permitting access to the interior of the cabinet. Additionally, sliding doors may also be used on the rear of the cabinet in lieu of panel 84.

The panels are conveniently mounted within tracks 66 and 68 on oppositely facing track members 64. The track members are mounted on the elongated members.

The top surface 92 of the cabinet may be closed by either a panel or a shelf.

In FIG. 5, a typical panel such as side panel 80 is shown to have a rectangular shape. Its inner surface may be smooth. However, if desired its outer surface 96 may have a pattern or design carved, molded or attached thereto.

Two of its opposite edges 98 are provided with elongated slots 100. The slots are closer to one of the surfaces of the panel than the other so that when a tab 48 is in the slot, top and bottom surfaces 38 and 40 are coplanar with the inner and outer surfaces of the panel. The remaining edges 102 of the panel 80 are smooth. The remaining panels are of identical construction so their same features are identified by the same numerals as utilized in connection with side panel 80.

The top surface 92 of the cabinet may comprise a shelf 106 which is supported by the inwardly facing tabs 48 on two opposite bars such as bars 28. As seen in FIGS. 8 and 9 the bars can be turned to accommodate a relatively thin shelf 106 or a relatively thick shelf 108. In each instance, the top surface of the shelf is coplanar with the adjacent surface of the bar.

The modular elements described thus far can be used to form a display assembly by an unskilled person working without benefit of tools, mechanical fasteners or the like.

In order to make an assembly from the modular elements, the elongated members are loosely connected to the joints to generally define the desired configuration. In order to permit the side, rear and bottom panels to be supported, one opposite set of each of the bars or columns defining the area to be closed is turned so that its tabs 48 face inwardly to be received in slots 100.

As best seen in FIGS. 2-4 side panels 80 are supported on either side by tabs 48 on columns 32 and 34. The side panels rest on bars 30 (FIGS. 3 and 5), however, there is no interengagement therebetween. Bars 30 have their tabs 48 turned inwardly to engage the slots 100 in bottom panel 82.

The rear panel is supported by the downwardly extending tab 48 on bar 24 and the upwardly extending tab on bar 26 (FIGS. 4 and 5). It is in close fitting rela-

tion with the sides of columns 34 (FIG. 2), however there is no interengagement therebetween since the tabs 48 on those elements are turned to engage the side panels 80.

5 Tabs 48 on bars 24 and 26 are turned inwardly into mutually facing relation. As explained above these bars could support a front panel, however it is preferred that they be used to support sliding doors 88 and 90.

10 In order to mount the sliding doors, two track members 64 are mounted in mutually facing relationship on bars 24 and 26 at the front of the cabinet. The tab 48 on each of the bars is slidably received in recesses 74 on each of the track members. The track members are held against the tabs by a mutually interengaging locking means which comprises the enlarged cavity 76 in each recess 74 and bulbous portion 50 on each of the tabs. Thus, the track members can not be removed from the bars 24 and 26 without being slid longitudinally thereof. Doors 88 and 90 are received within inner and outer tracks 66 and 68 on the top bottom track members 64 and constrained therebetween for sliding movement.

15 In FIG. 6 another embodiment 120 of a display assembly constructed from the various modular elements described heretofore is shown.

Thus display assembly 120 is comprised of elongated members defining columns 122, 124, 126 and 128 and bars 132, 134, 136 and 138.

20 Each of the elongated members in embodiment 120 have the same cross section and characteristics as those in embodiment 20. Thus, the bars and columns are interconnected at the corners of the assembly by corner joints 54.

25 Intermediate joints 140 connect vertically aligned columns 122 and 124 and 126 and 128 so that shelves and cabinets can be arranged in tiers.

30 As seen in FIG. 7, the intermediate joints 140 are similar to corner joints 54 to the extent that they have a cube shaped core 142 with legs 146 emanating from its faces. Thus upwardly and downwardly directed legs 146 interconnect columns 122 and 124. Each of the legs 146 has a projection 148 to cause a friction fit with its respective elongated member.

35 Each of the elongated members illustrated in FIG. 6 is provided with an outwardly directed tab 48. However, in order to simplify the description of the display assembly they have been omitted.

40 The second embodiment shows how a plurality of shelves 152 and 154 may be supported. Shelf 152 may be either thick or thin (FIGS. 8 and 9). Preferably it is supported along its longest sides by bars 132 and 134. The tabs 48 on these bars extend in the direction indicated by the arrows.

45 In like manner shelf 154 is supported by another set of bars 132 and 134, the tabs 48 of which are also directed inwardly as indicated by the arrows. The tabs on the remaining bars and columns are then arranged to accommodate the arrangement dictated by shelves 152 and 154.

50 It is apparent that a bottom shelf or side, bottom and rear panels could be arranged on the remainder of the second embodiment by arranging tabs 48 in the desired directions.

55 The joints 54 and 140 are an important aspect of the invention since the arrangement of the legs on the core will determine whether two, six or any intermediate number of elongated members will be joined thereby.

Thus, by selecting a joint with the correct number of legs, a display assembly can be lengthened, widened or increased in height. Additionally an increased number of shelves and cabinets can be provided in any desired arrangement.

Advantageously, the display assembly permits the use of novel and interesting supports for carrying advertising or display signs. One of these supports is illustrated in FIG. 11. There, a hook 160 having a square configuration is arranged to fit over one of the elongated members such as bar 132. One of the hook legs 162 is short enough so that it can be carried on a bar when the bar is turned to support a relatively thin shelf. Because the hook 160 has a square configuration, it may be constrained between the edge of the shelf 154 and one of the surfaces of the bar. The depending leg 164 may be connected to a sign 166 by a cord 168 threaded through a hole 170 therein.

A second type of support 176 is illustrated in FIG. 12. This support can be used to support an item such as a card 178.

The support is a U-shaped member having two depending legs 180 and a web 182 spanning therebetween. Preferably, the U-shaped member is made of a resilient material so that legs 180 are biased inwardly to grasp a bar such as bar 132 on which they are supported.

Preferably, legs 180 are long enough to provide a secure anchor on the bar however they are short enough so that the support may be carried on the bar when it is turned to support a thin shelf.

The web 182 carries a second upwardly directed U-shaped member 184. Member 184 has front and rear legs 186 and 188, carried by a web 190. The web 190 is mounted to web 182. A display item such as card 178 is supported between the legs 186 and 188 and is constrained thereby.

Thus, what has been described is a modular display assembly which is readily assembleable or disassembleable without the use of tools fastening means or any other assistance. The assembly is comprised of a plurality of modular elements which can be assembled as desired by an unskilled person to achieve a unitary structure of desired configuration.

Thus, while the invention herein has been described with respect to a number of forms and embodiments thereof it is apparent that many other forms and embodiments will be obvious to those skilled in the art in view of the foregoing description. Thus the scope of the invention should not be limited by the foregoing description, but rather only by the scope of the claims appended hereto.

We claim:

1. An article to be used in the construction of a modular assembly comprising first and second elongated members, said first member defining at least two elongated tracks disposed in side-by-side spaced parallel relation for slidably receiving panels therein, each of said tracks facing in a first direction, an elongated recess defined by said first member, said recess having an enlarged elongated cavity at its closed end and being disposed between two of said tracks in a direction opposite to said first direction, said second elongated member having a plurality of sides, one of said sides supporting an outwardly directed tab in a plane substantially perpendicular to said supporting side, said tab comprising an elongated bulbous member on its free edge, and

said elongated bulbous member on the free edge of said tab and said enlarged elongated cavity at the closed end of said recess for receiving said bulbous member define mutually interengaging means for constraining said track member and said elongated member for relative longitudinal sliding movement.

2. A cabinet, the edges of said cabinet being comprised of a plurality of elongated members, each of said elongated members having at least two opposite sides, the corners of said cabinet being comprised of a plurality of joint members, some of said joint members being operative to join at least three of said elongated members to define a corner, the sides of said cabinet being defined by a plurality of rectangular panels, said panels defining slots in at least two of their opposite edges, each of said elongated members including an outwardly directed tab, said tabs being disposed between said opposite sides of said elongated members, a set comprising two of said elongated members in oppositely facing relation to each other and being adjacent to said opposite edges of said panels, two others of said elongated members being disposed adjacent said other sides of said panels, said tabs on said oppositely facing elongated members being in mutually facing relation and being received in said slots in said oppositely facing edges of said panels, and said tabs on said other two of said elongated members are turned away from mutually facing relation so that they can support other panels.

3. A cabinet as defined in claim 2 comprising another set of elongated members having oppositely facing tabs, said elongated members in said other set being positioned so that one of said elongated members is above and spaced from the other with said tabs being in mutually facing relation, second elongated members defining parallel spaced elongated track means, a recess in each of said second elongated members for engaging said tabs so that said upper and lower tracks are in mutually facing relation, said recesses being disposed intermediate said track means and in oppositely facing relation thereto, and a plurality of panels slidably received in said tracks to define sliding doors.

4. A cabinet as defined in claim 2 including means for supporting card means, said supporting means having first and second depending legs with a web disposed therebetween so that said supporting means can be carried on one of said elongated members, and at least one of said depending legs being of sufficient size to be against said elongated member between said tab and said one side.

5. A cabinet as defined in claim 4 wherein said other leg is substantially longer than said one leg to depend below said elongated member, and said other leg has means thereon for supporting card means.

6. A cabinet as defined in claim 4 wherein said web supports upwardly directed spaced legs for engaging and supporting card means therebetween.

7. A connector for use with a modular display assembly comprising a core, said core having a plurality of faces, at least two of said faces having legs outwardly directed therefrom, said legs having a smaller cross section than said respective faces so that a ledge is formed on each of said faces at its juncture with its respective leg, the width of each of said ledges being the same as the wall thickness of a hollow member to be slipped over said leg, and each of said legs having a raised portion on its surface to frictionally engage the interior of said hollow member.

* * * * *