



US 20050016750A1

(19) **United States**

(12) **Patent Application Publication**
Zimmerman

(10) **Pub. No.: US 2005/0016750 A1**

(43) **Pub. Date: Jan. 27, 2005**

(54) **METHODS FOR ENCLOSING A THERMOPLASTIC PACKAGE**

Related U.S. Application Data

(62) Division of application No. 10/767,309, filed on Jan. 29, 2004.

(75) Inventor: **Michael Zimmerman**, North Andover, MA (US)

(60) Provisional application No. 60/443,470, filed on Jan. 29, 2003.

Correspondence Address:
WEINGARTEN, SCHURGIN, GAGNEBIN & LEBOVICI LLP
TEN POST OFFICE SQUARE
BOSTON, MA 02109 (US)

(30) **Foreign Application Priority Data**

Jan. 29, 2004 (WO)..... PCT/US04/02464

Publication Classification

(51) **Int. Cl.⁷** **H05K 5/06**
(52) **U.S. Cl.** **174/52.3**

(73) Assignee: **QUANTUM LEAP PACKAGING, INC.**

(57) **ABSTRACT**

A circuit package for housing semiconductor or other integrated circuit devices ("die") includes a high-copper flange, one or more high-copper leads and a liquid crystal polymer frame molded to the flange and the leads. A lid is welded to the frame after a die is attached to the flange.

(21) Appl. No.: **10/920,643**

(22) Filed: **Aug. 18, 2004**

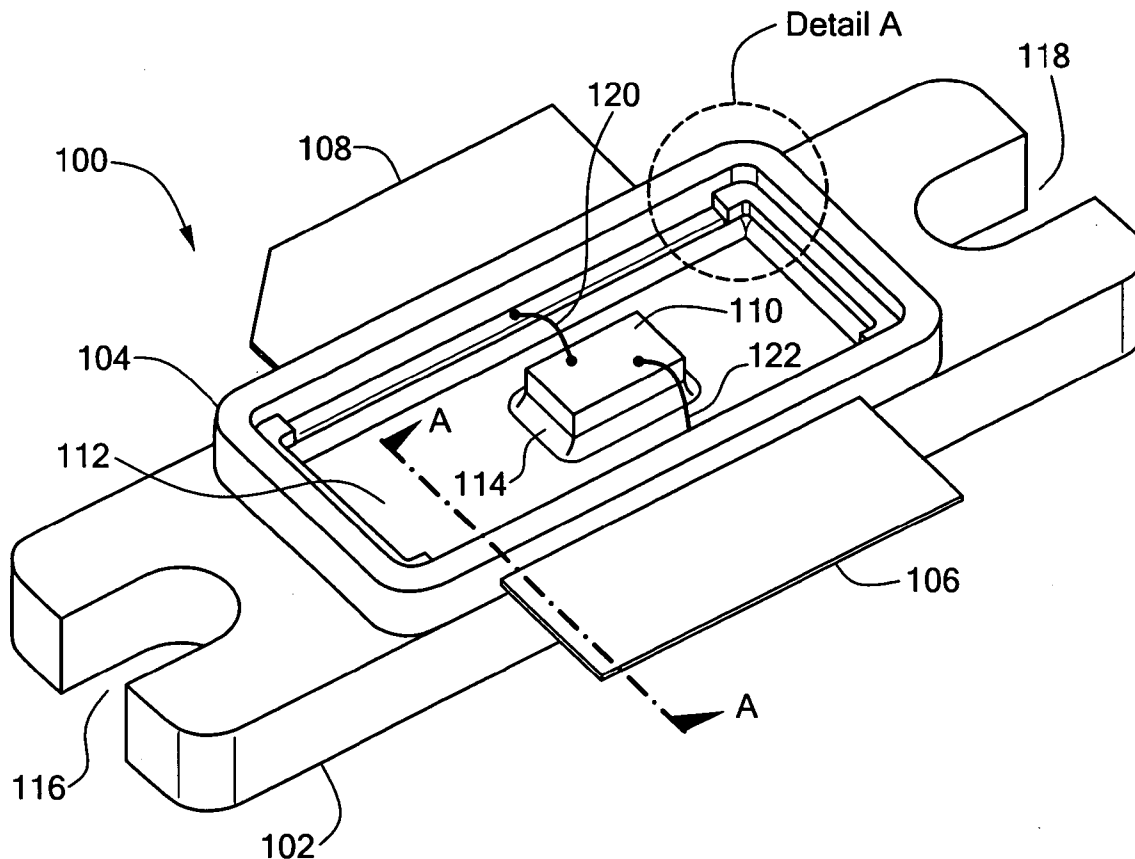

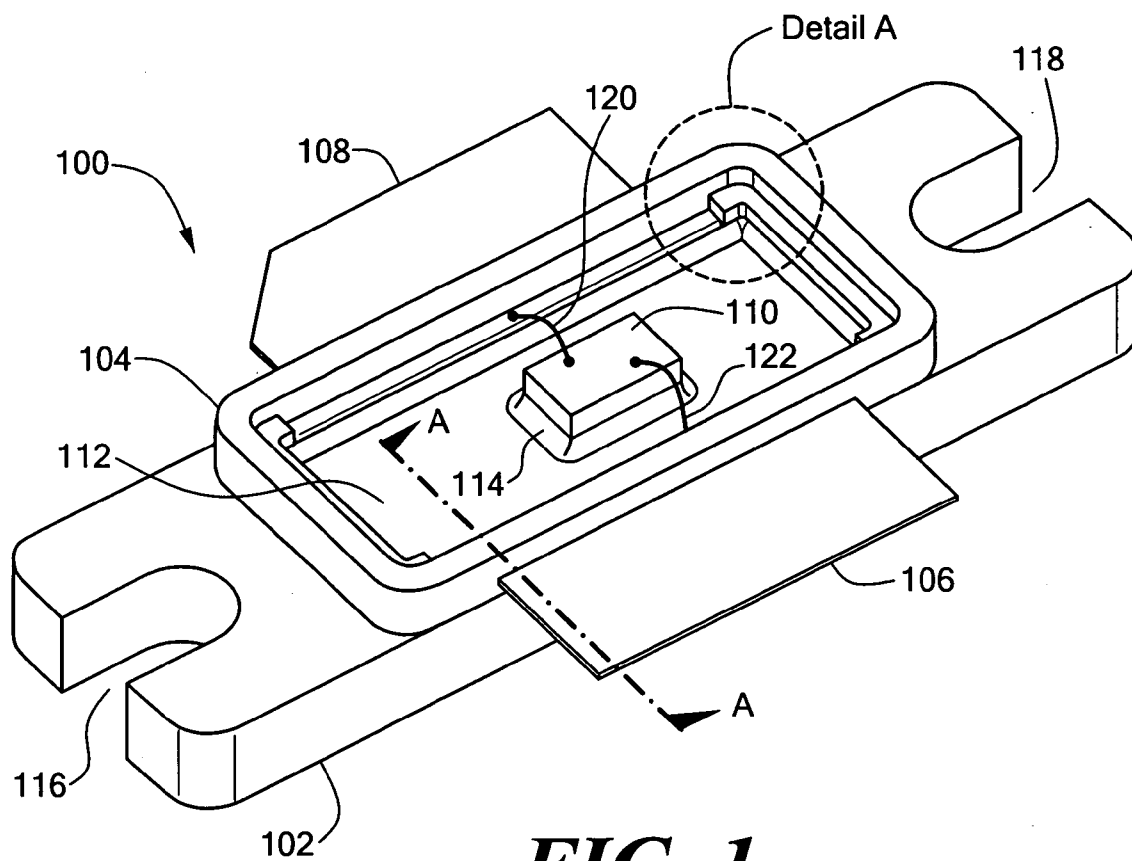

FIG. 1

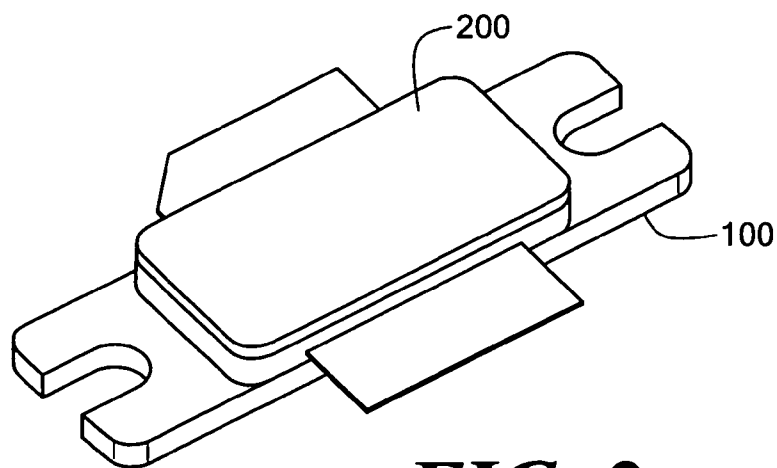

FIG. 2

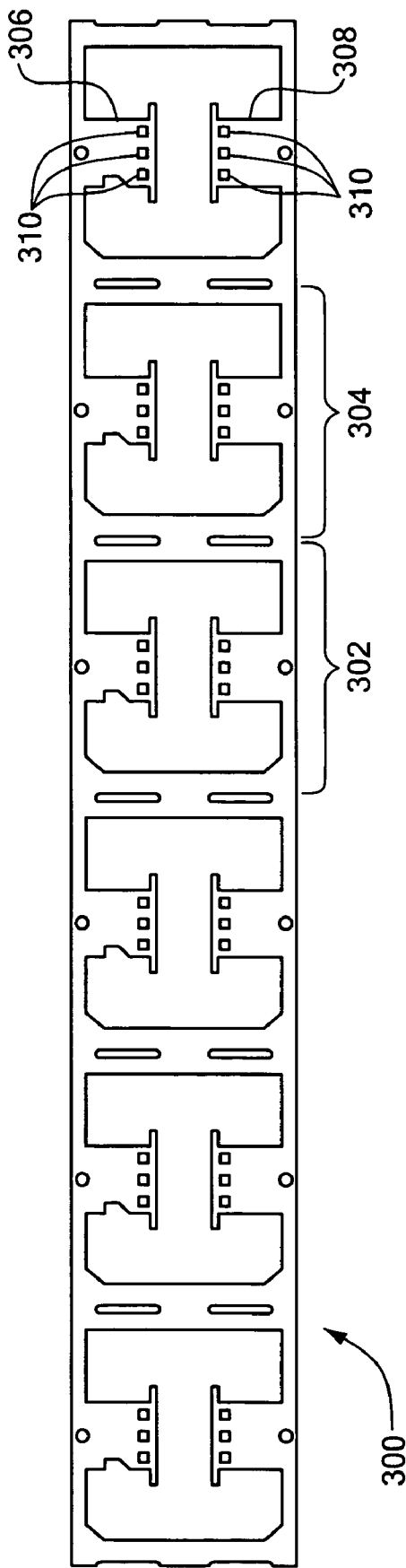

FIG. 3

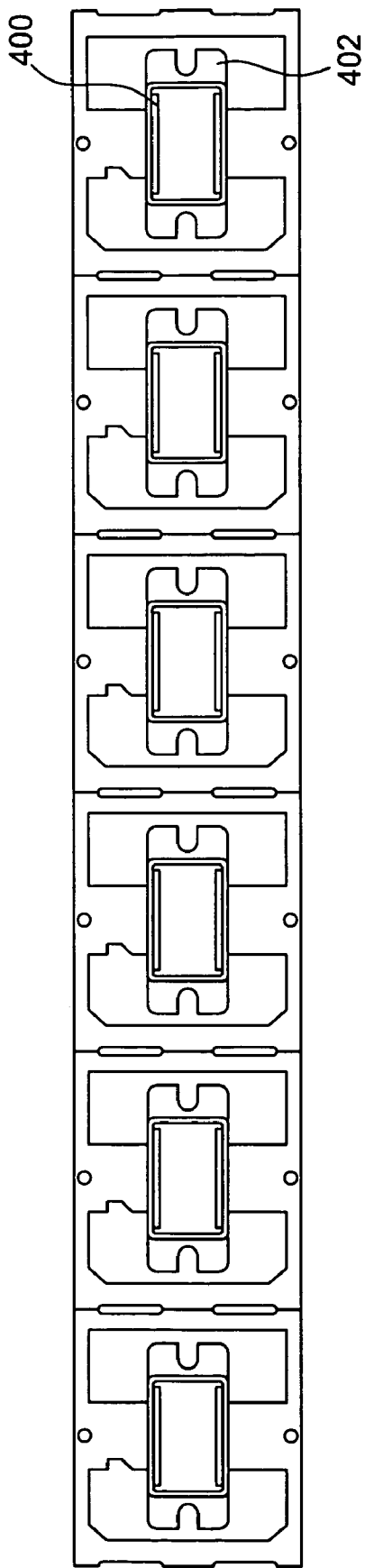

FIG. 4A

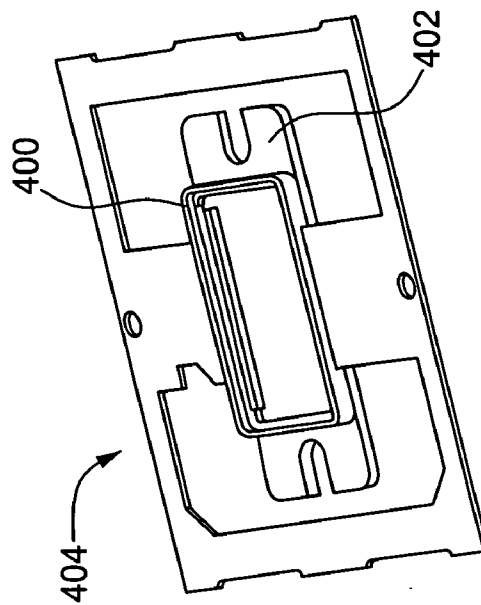

FIG. 4B

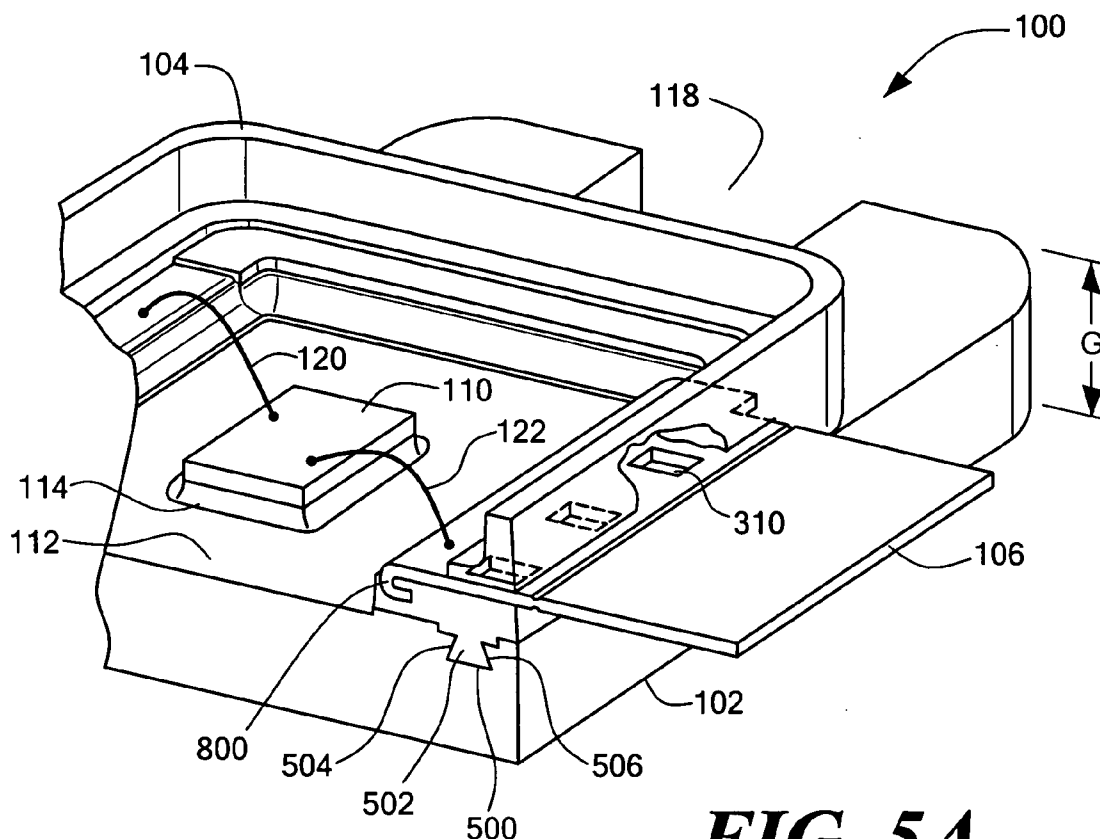

FIG. 5A

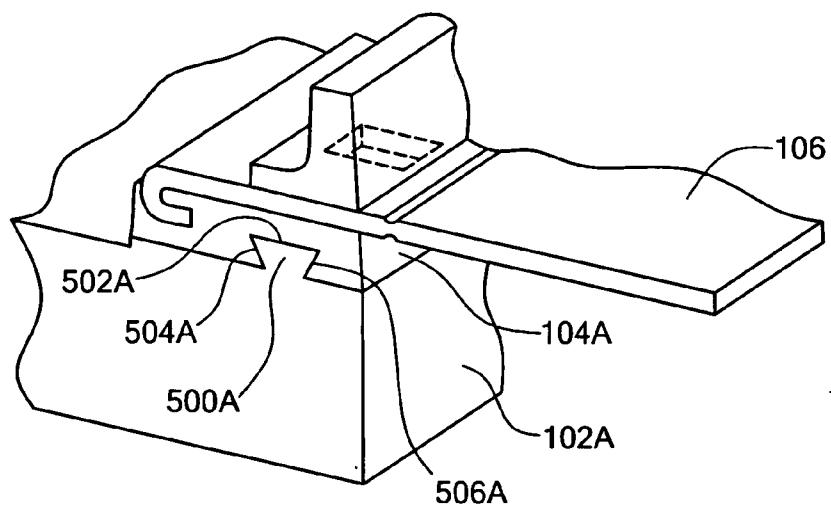

FIG. 5B

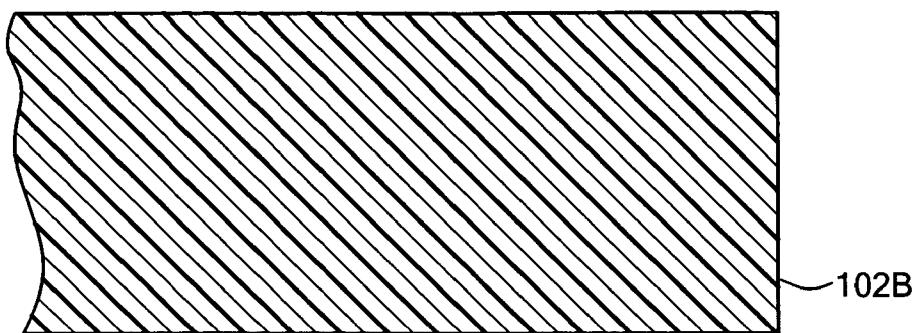

FIG. 6A

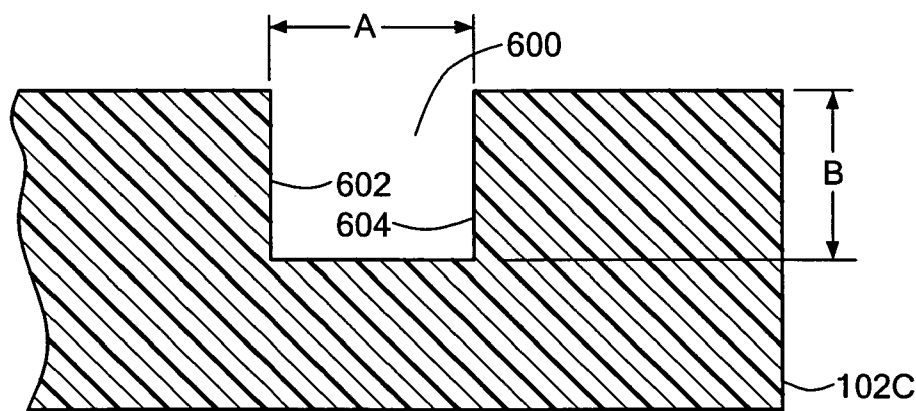

FIG. 6B

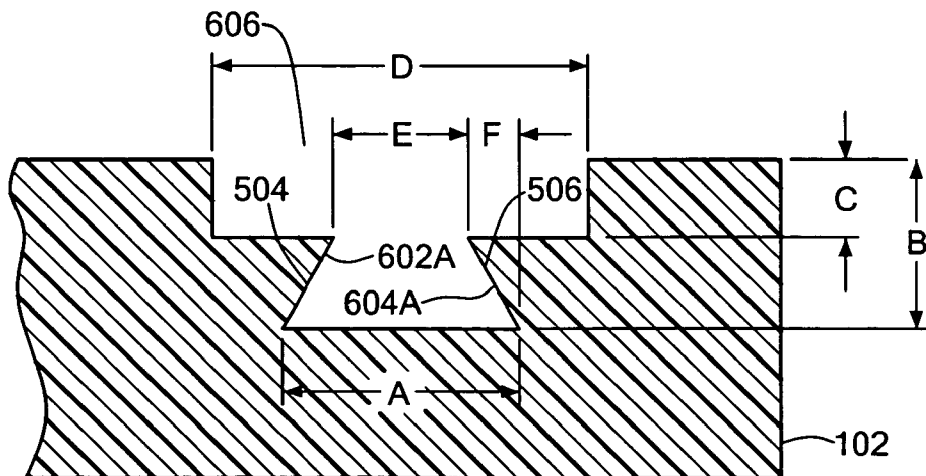

FIG. 6C

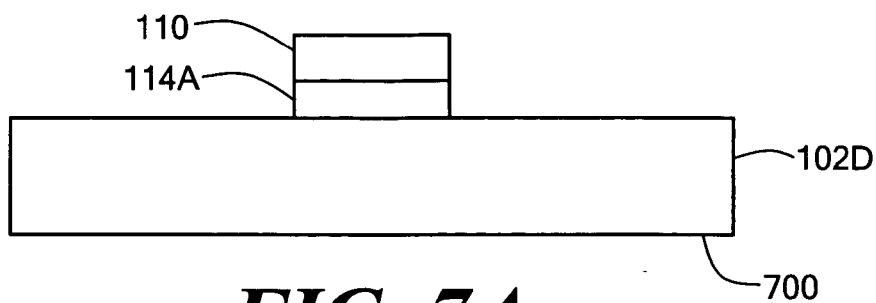

FIG. 7A

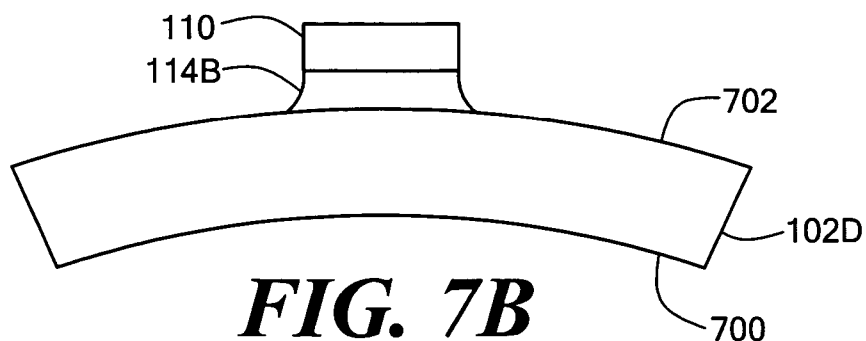

FIG. 7B

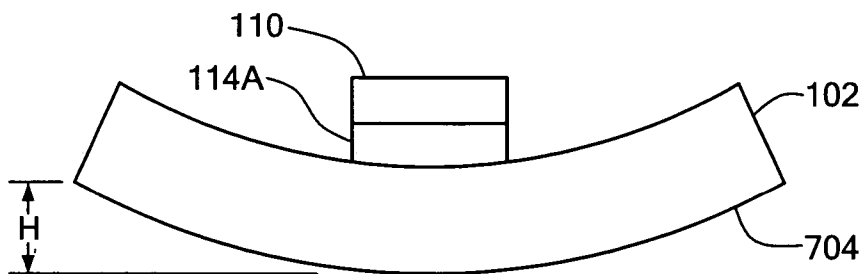

FIG. 7C

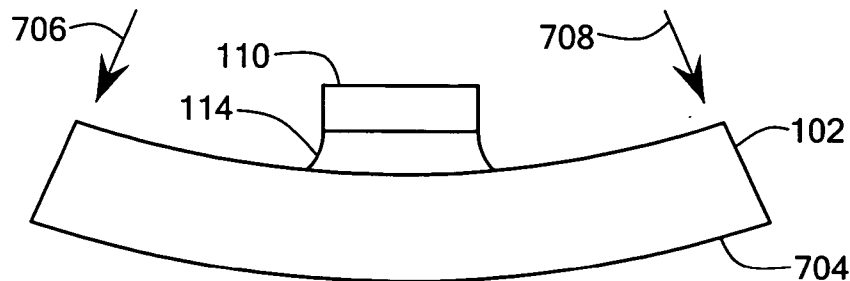

FIG. 7D

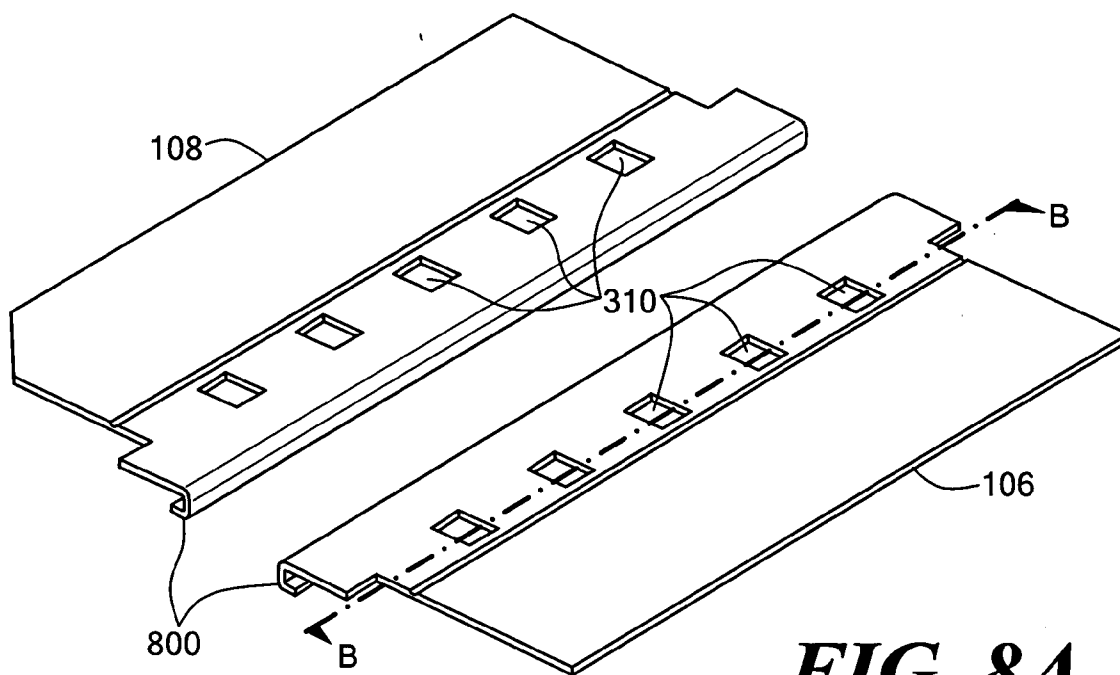

FIG. 8A

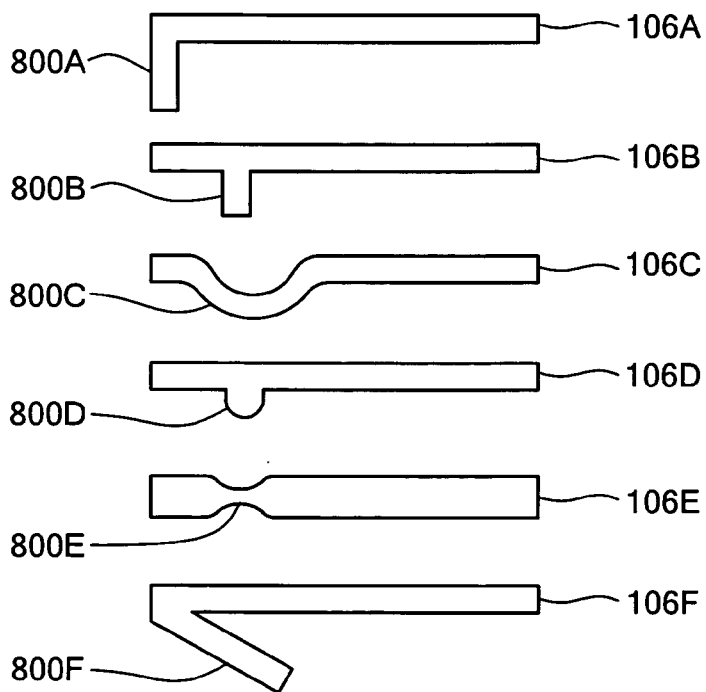

FIG. 8B

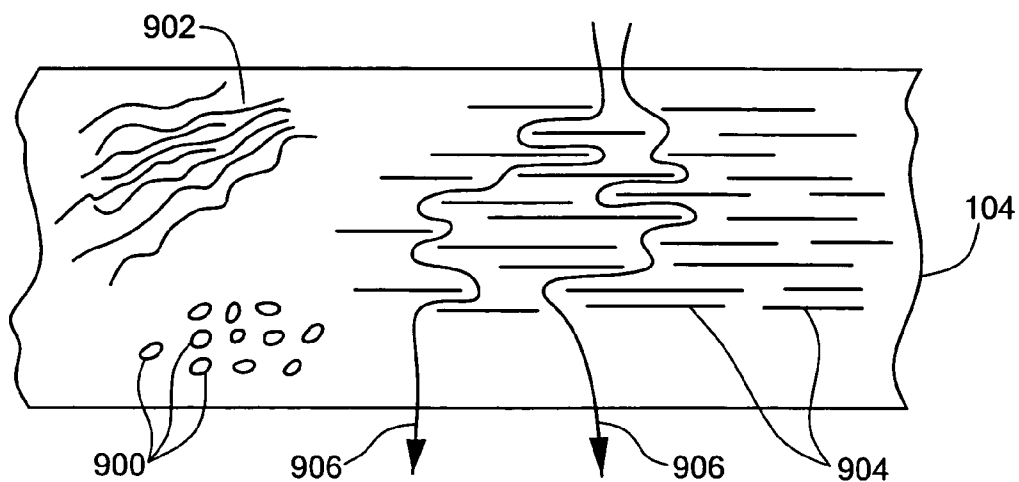
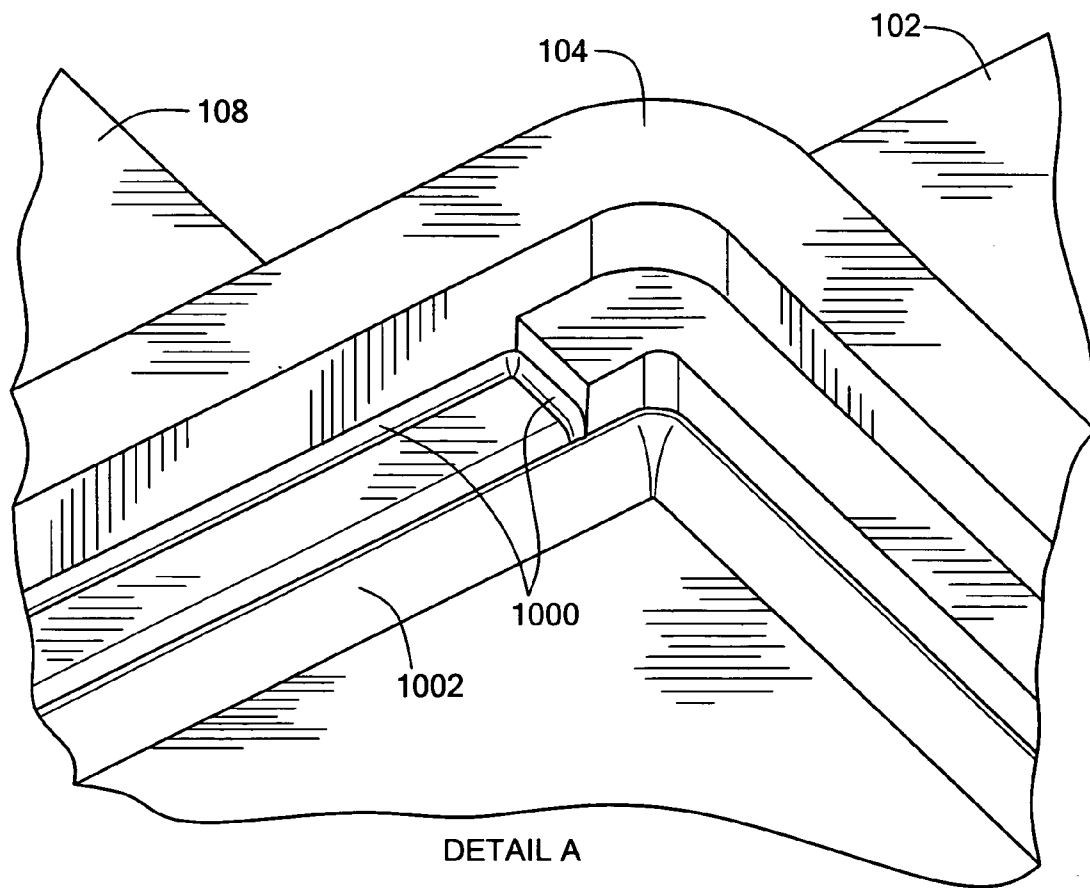

FIG. 9



DETAIL A

FIG. 10

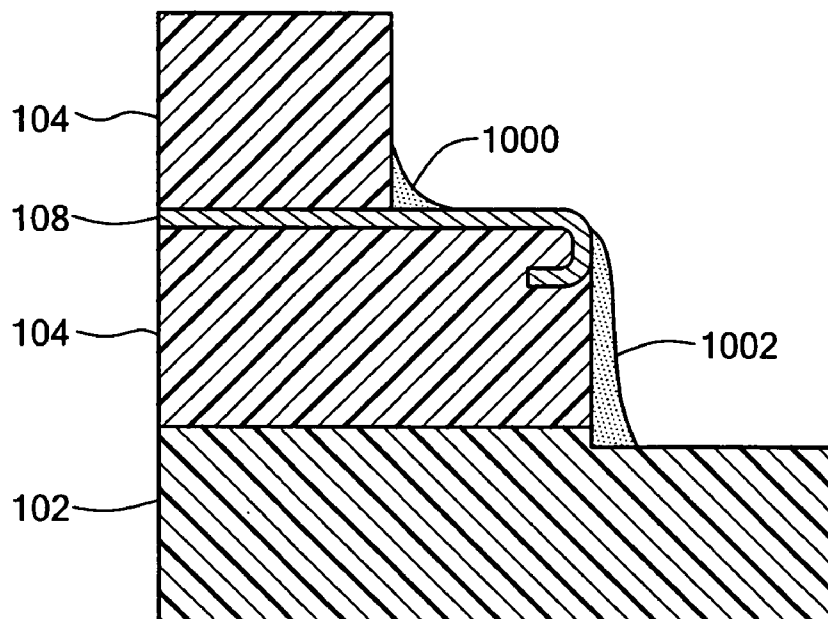

FIG. 11A

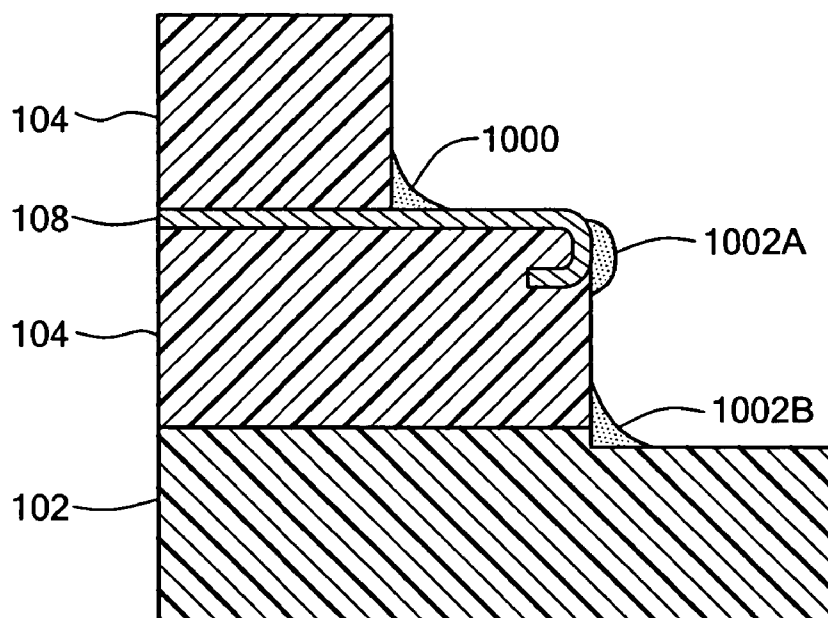

FIG. 11B

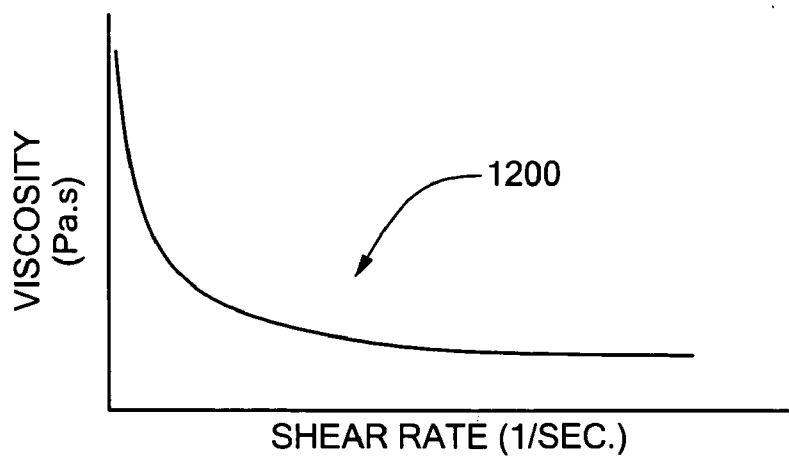

FIG. 12

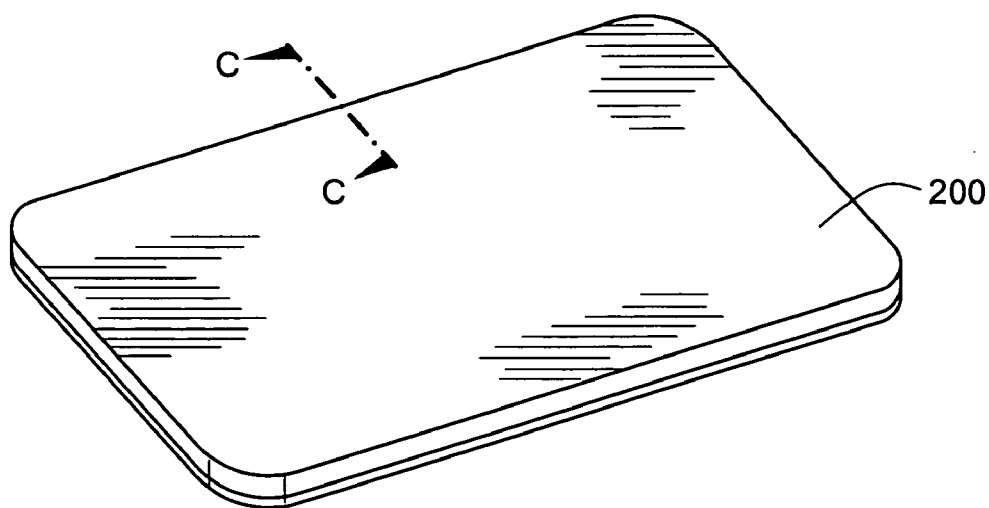
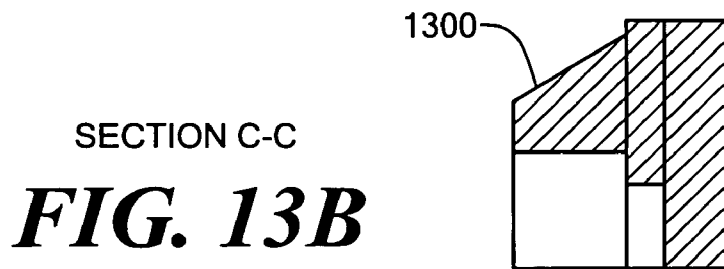

FIG. 13A



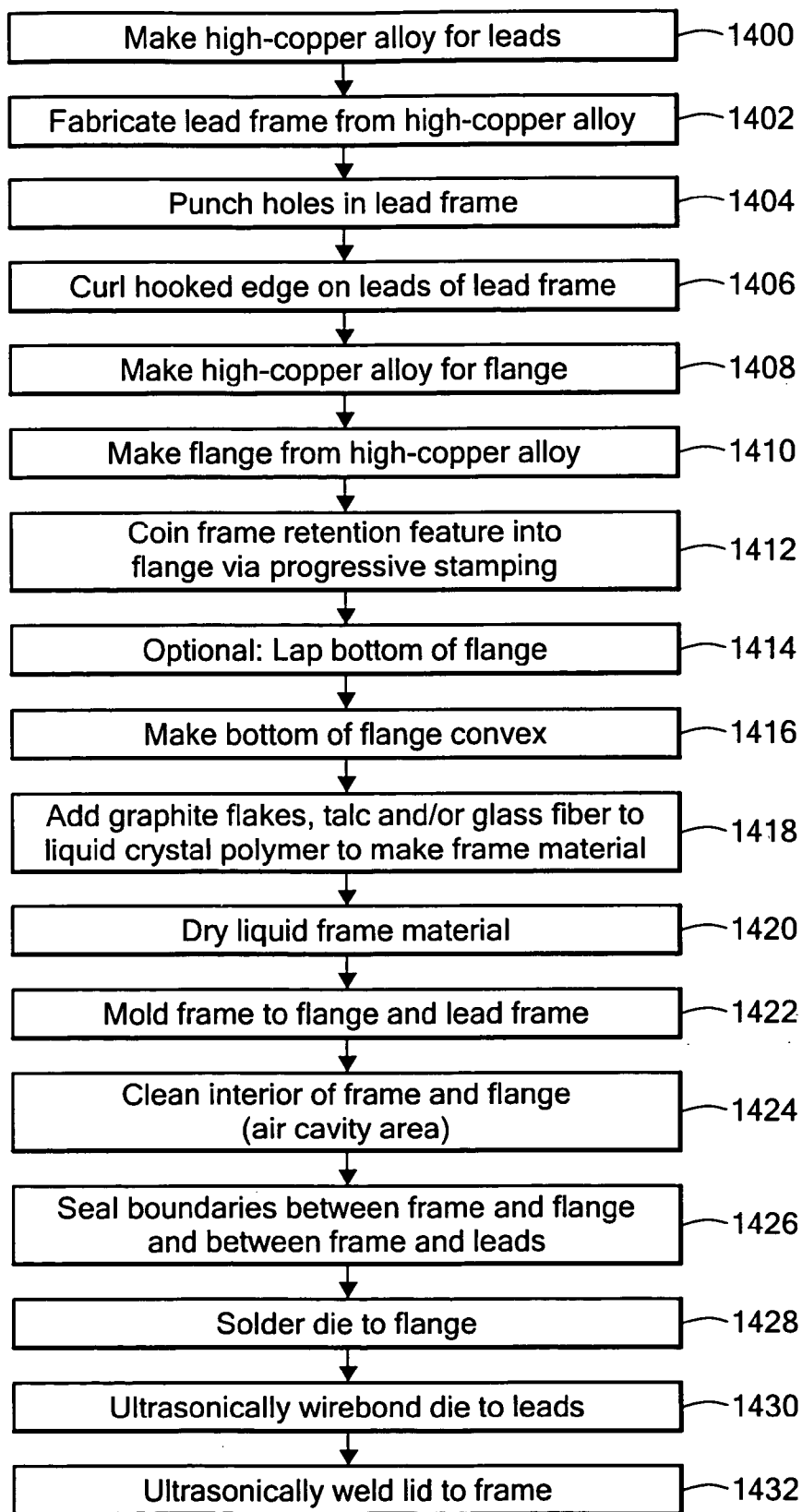

FIG. 14

METHODS FOR ENCLOSING A THERMOPLASTIC PACKAGE

CROSS REFERENCE TO RELATED APPLICATIONS

[0001] This application is a divisional of application Ser. No. 10/767,309, filed Jan. 29, 2004, which claims the benefit of provisional Application No. 60/443,470, filed Jan. 29, 2003.

STATEMENT REGARDING FEDERALLY SPONSORED RESEARCH OR DEVELOPMENT

[0002] Not Applicable

BACKGROUND OF THE INVENTION

[0003] This application relates to circuit packages for integrated circuits and, more particularly, to circuit packages that include metal flanges and high-temperature thermoplastic frames.

[0004] Semiconductor and other integrated circuit devices (sometimes referred to as “chips” or “die”) are typically mounted inside circuit packages to protect the die and to facilitate electrically, mechanically and thermally connecting the die to printed circuit boards, heat sinks and the like. A typical circuit package includes a base (commonly referred to as a “slug” or “flange”), a protective insulating housing and leads extending through the housing. Inside the housing, the leads are electrically bonded directly, or more commonly by wires, to contacts on the die.

[0005] The protective housing is made of a dielectric material, such as plastic or ceramic, and is attached to the flange to encapsulate the die and bonding wires and to protect them against intrusion of water vapor and other atmospheric gases. Most protective housings comprise two pieces, i.e. a set of sidewalls (a “frame”) and a lid, although some housings are molded as one-piece assemblies. The order in which the frame and the die are attached to the flange varies, depending on the material of the frame and, more particularly, the maximum temperature the material can tolerate without deforming or being otherwise damaged.

[0006] A circuit package for a high-power die typically includes a metal flange, to which the die is attached, often by eutectic soldering. The flange typically provides mounting features, such as screw holes or slots, by which the circuit package can be mounted, such as to a heat sink. In use, the flange conducts heat from the die to the heat sink.

[0007] The high temperature used to attach a die to a flange can damage or deform plastic, however ceramic materials are able to withstand this high temperature. A circuit package that employs a ceramic frame can, therefore, be assembled prior to the attachment of the die. A lid is then adhered to the frame, such as by epoxy.

[0008] To match the coefficients of thermal expansion of ceramic frames, flanges for these frames are typically made of a copper-tungsten alloy by a powder metallurgy infiltration process. This process is very expensive, and the thermal conductivity of the resulting alloy is limited. Improved thermal conductivity can be achieved through the use of copper-molybdenum-copper laminated flanges fabricated by

an infiltration process followed by a lamination process, however these processes are very expensive.

[0009] Alternatively, the die can be attached to the flange prior to attaching the frame and lid. This approach enables use of low-temperature plastic for the frame, however adhesives used to attach the frame to the flange and to the lid perform less than satisfactorily. These adhesives often create imperfect seals or permit gaps to open during use of the circuit package. Furthermore, users of circuit packages prefer not to inventory flanges, frames and lids and assemble these pieces after attaching die to flanges.

BRIEF SUMMARY OF THE INVENTION

[0010] The present invention provides a low piece-count, low cost circuit package that can withstand high die-attach temperatures and can provide a hermetically sealed air cavity for a die, without the use of adhesives. The circuit package design employs a number of mechanical features and compositions to achieve this hermeticity and temperature tolerance. This combination also provides a circuit package that exhibits better electrical and thermal conductivity and mechanical integrity than conventional circuit packages.

[0011] The circuit package includes two parts: a flange/frame/lead(s) combination and a lid. The leads extend through sidewalls of the open-top frame. The flange includes a die-attach area surrounded by the frame. A seal is applied inside the frame along boundaries between the flange and the frame and between the leads and the frame. Materials for the frame (thermoplastic, preferably liquid crystal polymer) and seal (preferably epoxy) are formulated to withstand die-attach temperatures. Once a die is attached to the flange and the die is electrically bonded to the leads, the lid is welded to the frame to seal the air cavity around the die.

[0012] The flange, frame and leads of the circuit package include one or more structural features to maintain mechanical integrity of the circuit package without use of adhesives. These features mechanically lock the flange and leads to the frame at their respective junctions.

[0013] In one embodiment, the flange defines a frame retention feature surrounding the die-attach area. The retention feature can be, for example, a groove or ridge that includes a dovetail or other undercut cross-sectional shape. The thermoplastic frame is molded to the flange, such as by injection molding. During molding, a portion of the frame forms a key that freezes in or around the retention feature, thus mechanically securing the frame to the flange.

[0014] In another embodiment, each lead includes one or more lead retention features to secure the lead to the frame. During the molding operation, the frame is also molded around the lead, which extends from outside the frame, through a sidewall of the frame, into the air cavity area.

[0015] One lead retention feature defines at least one hole through the lead. During molding, some frame thermoplastic flows through, and then freezes in, the hole, thus locking the lead within the frame.

[0016] Another lead retention feature provides a hooked edge, ridge or other structure on or near the end of the lead that resides within the air cavity area. This structure is not co-planar with the lead. During molding, some frame ther-

moplastic freezes against an outward-facing portion of this structure, thereby creating a mechanical barrier that prevents the lead from being pulled out of the frame.

[0017] Compositions of the flange, frame and leads provide matching coefficients of thermal expansion (CTE), thus reducing stress on the respective junctions between these parts. These compositions also provide good thermal conductivity by the flange and good electrical conductivity by the leads and the flange. In one embodiment, the flange is made with a high copper content, augmented by a small amount of zirconium, silver or other material. In another embodiment, the leads are made with a high copper content, augmented by a small amount of iron, phosphorus, zinc and/or other material. In yet another embodiment, graphite flakes in the frame form a moisture barrier. These graphite flakes and other additives match the CTE of the frame to the CTE of the flange. An optional film can be applied to the exterior or interior of the frame and/or lid to further reduce moisture infiltration into the air cavity.

BRIEF DESCRIPTION OF THE SEVERAL VIEWS OF THE DRAWINGS

[0018] These and other features, advantages, aspects and embodiments of the present invention will become more apparent to those skilled in the art from the following detailed description of an embodiment of the present invention when taken with reference to the accompanying drawings, in which:

[0019] **FIG. 1** is a perspective view of a circuit package, without a lid, according to one embodiment of the present invention;

[0020] **FIG. 2** is a perspective view of the circuit package of **FIG. 1** with a lid attached thereto;

[0021] **FIG. 3** is a top view of a strip of lead frames, such as those used to manufacture the circuit package of **FIG. 1**;

[0022] **FIG. 4A** is a top view of the strip of lead frames of **FIG. 3** after frames and flanges have been molded thereto;

[0023] **FIG. 4B** is a perspective view of one lead frame of the strip shown in **FIG. 4A**;

[0024] **FIG. 5A** is a cut-away view of a portion of the circuit package of **FIG. 1**;

[0025] **FIG. 5B** is a cut-away view of a portion of an alternative embodiment of the circuit package of **FIG. 1**;

[0026] **FIGS. 6A-C** are cross-sectional views of the flange of the circuit package of **FIG. 1** showing three stages of manufacture thereof;

[0027] **FIGS. 7A-D** are schematic drawings of a die being attached to the flange of the circuit package of **FIG. 1**;

[0028] **FIG. 8A** is a detailed perspective view of the leads of the circuit package of **FIG. 1**;

[0029] **FIG. 8B** is a cross-sectional diagram of several alternative embodiments of the leads of the circuit package of **FIG. 1**;

[0030] **FIG. 9** is a schematic cross-sectional diagram of a portion of the frame of the circuit package of **FIG. 1**;

[0031] **FIG. 10** is an enlarged view of a portion of the circuit package of **FIG. 1** showing seals;

[0032] **FIGS. 11A and 11B** are cross-sectional views of the circuit package of **FIG. 1** showing two embodiments of the seals of **FIG. 10**;

[0033] **FIG. 12** is a graph showing a relationship between viscosity and shear rate of one embodiment of a material suitable for use as the seal of **FIGS. 10, 11A and 11B**;

[0034] **FIG. 13A** is a perspective view of a lid for the circuit package of **FIG. 1**;

[0035] **FIG. 13B** is a cross-sectional view of a portion of the lid of **FIG. 13A**, according to one embodiment; and

[0036] **FIG. 14** is a flowchart of a process of making the circuit package of **FIG. 1**.

DETAILED DESCRIPTION OF THE INVENTION

[0037] The contents of application Ser. No. 10/767,309, filed Jan. 29, 2004, and the contents of provisional Application No. 60/443,470, filed Jan. 29, 2003, are hereby incorporated by reference.

[0038] The present invention provides a low piece-count circuit package that can withstand high die-attach temperatures and can provide a hermetically sealed air cavity for a die, without the use of adhesives. **FIG. 1** shows an exemplary circuit package **100**, according to one embodiment of the present invention. For clarity, the circuit package **100** is shown without a lid. The circuit package **100** includes a flange **102**, a frame **104** and two leads **106** and **108**. The frame **104** electrically insulates the leads **106** and **108** from the flange **102** and each other. A die **110** is attached to a die-attach area **112**, such as by eutectic solder **114**. For clarity, **FIG. 1** shows only one die, although typically two or more die can be attached to the die-attach area **112**.

[0039] The eutectic solder **114** electrically bonds the die **110** to the flange **102**. The eutectic solder **114** also conducts heat away from the die **110** to the flange **102**. In use, the flange **102** is typically mounted to a heat sink (not shown) by bolts (not shown) extending through slots **116** and **118**. The die **110** is electrically bonded to the leads **106** and **108**, such as by wires **120** and **122**. These wires **120** and **122** are preferably ultrasonically bonded to the leads **106** and **108**. Although one die **110** and two leads **106** and **108** are shown, more die and/or leads can be used. **FIG. 2** shows the circuit package **100** after a lid **200** has been attached thereto, as described in more detail below.

[0040] The circuit package **100** employs a number of mechanical features and compositions to hermetically seal the die within the air cavity and to tolerate high temperatures. As previously noted, this combination also enables the circuit package **100** to exhibit enhanced electrical and thermal conductivity and mechanical integrity. The following description begins with an overview of a process for manufacturing the circuit package **100**. There then follows a detailed description of the flange **102** and its manufacture. This is followed by detailed descriptions of the leads **106** and **108**, composition of the liquid crystal polymer used for the frame **104**, a seal applied inside the frame **104**, the lid **200** and a process for manufacturing the circuit package **100**.

Manufacturing Overview

[0041] Circuit packages **100**, according to the present invention, are preferably fabricated in strips or on reels,

similar to conventional circuit packages. FIG. 3 shows a strip 300 of lead frames, such as lead frames 302 and 304. Each lead frame includes two leads, such as those shown at 306 and 308. In one embodiment, when the lead frame strip 300 is stamped or etched, holes are created through the leads 306 and 308. Examples of these holes are shown at 310. These holes 310 are used to lock a frame to the leads 306 and 308, as described in detail below.

[0042] After the lead frame strip 300 is made, a frame is molded, preferably by injection molding, to each lead frame of the lead frame strip. FIG. 4A shows the lead frame strip 300A after frames, such as frame 400, have been molded to the lead frames. FIG. 4B shows one complete lead frame 404. Lead frames can be supplied individually or in strips or reels to subsequent manufacturers, who attach die to them.

Flange

[0043] The flange 102 forms a base, to which other parts of the present circuit package are attached. In addition, the flange 102 typically conducts heat from a die to a heat sink and electrically bonds one terminal of the die to a circuit board. The flange 102 is preferably made of a high-copper alloy (at least about 50% copper) to provide high electrical and thermal conductivity and to resist annealing at die-attach temperatures. The alloy preferably includes at least one trace metal. The flange 102 preferably comprises at least about 98% copper and between about 0.05% and about 1.5% zirconium, although other high-copper ratios are acceptable. The flange 102 more preferably comprises about 99.9% copper and about 0.1% zirconium. The flange 102 is preferably electroplated with about 100 micro-inches of nickel to form a diffusion barrier layer and about 65 micro-inches of gold to facilitate soldering the die 110 to the flange.

[0044] Alternatively, the flange 102 comprises at least about 99.5% copper and about 0.085% silver, although other high-copper ratios are acceptable. Zirconium is preferred to silver, because an alloy made with zirconium can contain a higher copper content and thus provide better thermal and electrical conductivity than if it is made with silver. The copper-zirconium alloy provides a flange with a thermal conductivity superior to prior art copper-tungsten and copper-molybdenum-copper flanges, which enables a circuit package that employs such a flange or a die attached to such a flange to dissipate more power than prior art packages. In addition, the copper-zirconium alloy has a higher annealing temperature than most high-copper alloys and is subject to less warpage as a result of being heated to die-attach temperatures.

[0045] As previously noted, the frame 104 is molded, preferably by injection molding, to the flange 102. As a result of this molding, the frame adheres to the flange 102, although this adhesion is typically imperfect and subject to breakdown due to the heat of soldering and operation of the die. To overcome this problem, the flange 102 preferably includes a mechanical feature to mechanically interlock the frame 104 and the flange.

[0046] This feature is shown in FIG. 5A, which is a cut-away view of a portion of the circuit package 100 discussed above with reference to FIG. 1. The flange 102 defines a frame retention feature 500, which is used to mechanically interlock the frame 104 and the flange. When the frame 104 is molded to the flange 102, some of the frame material flows

into, and then freezes in, the frame retention feature 500, forming a key 502. The frame retention feature 500 has a cross-sectional profile, and the key 502 takes on a complementary profile. Thus, the frozen key 502 mechanically interlocks with the frame retention feature 500, thereby preventing the frame 104 from being pulled away from the flange 102 without requiring an adhesive to be added between the frame and the flange.

[0047] The frame retention feature 500 includes at least one undercut portion. In cross-section, the retention feature 500 is preferably a dovetail shape, which defines two undercut portions 504 and 506. Other cross-section shapes, such as a T, L or lollipop, are acceptable.

[0048] Although the frame retention feature 500 shown in FIG. 5A is depressed below the adjacent surface of the flange 102, the frame retention feature can alternatively stand proud of the adjacent surface, as shown in FIG. 5B. Alternative flange 102A defines a frame retention feature 500A that stand proud of the adjacent surface. When a frame 104A is molded to the flange 102A, some of the frame material flows around, and freezes below, undercut portions 504A and 506A of the frame retention feature 500A. In this case, the frame 104A defines a key 502A that is within the frame 104A.

[0049] Returning to FIG. 5A, the frame retention feature 500 is formed in the flange 102 by a series of progressive stampings. FIGS. 6A-C show cross-sections of the frame retention feature 500 at various stages of manufacture. FIG. 6A shows a flange blank 102B before the frame retention feature 500 has been made.

[0050] FIG. 6B shows a flange blank 102C after a first rectangular cross-section groove 600 has been coined in the flange blank. This coining operation creates walls 602 and 604 in the groove 600. The groove 600 is preferably about 0.02 inches wide (dimension A) and preferably about 0.02 inches deep (dimension B).

[0051] FIG. 6C shows the flange 102 after a second rectangular cross-section groove 606 has been coined over the first groove 600. The second coining operation deforms the walls 602 and 604 (FIG. 6B), causing them to collapse slightly near the top of the groove. Deformed walls 602A and 604A form the undercuts 504 and 506 discussed above, with reference to FIG. 5A. The second groove 606 is preferably about 0.05 inches wide (dimension D) and preferably about 0.01 inches deep (dimension C). The resulting dovetail shape has a smaller dimension of about 0.007 inches (dimension E), leaving an overhang of about 0.0065 inches (dimension F). The overhang (F) is preferably at least about 0.005 inches for the liquid crystal polymer (described below) used for the frame 104.

[0052] All these dimensions can vary depending on the size, material and temperature of the flange 102, the size, material and temperature of the frame 104, the desired strength of the junction between the flange and the frame, cost or other factors that are now well within the skill of an ordinary practitioner.

[0053] The flange 102 also includes a mechanical feature to ensure a good heat transfer connection between the flange and a heat sink. Heat sinks are typically machined flat on one surface. To provide a good heat-conducting junction

between a circuit package and a heat sink, the circuit package should lie flat against this flat surface, without gaps therebetween.

[0054] The stamping operations (described above) performed to create the frame retention feature **500** can deform the bottom of the flange **102**, thereby preventing the circuit package from lying flat against the heat sink. To ameliorate this deformation, the bottom of the flange **102** is preferably lapped after the stamping operations. In addition or alternatively, increasing the thickness (dimension G in FIG. 5A), preferably to about 0.125 inches, can reduce the amount of deformation caused by the stamping operations and can eliminate the need to lap the bottom of the flange **102**.

[0055] Differences in coefficients of thermal expansion (CTE) between the die **110** and the flange **102** can deform the flange when the die is soldered to the flange. FIGS. 7A-D schematically illustrate this circumstance. FIG. 7A shows a flange **102D** with a flat bottom **700** and a die **110** that has not yet been soldered to the flange. Solder material **114A** has not yet been melted. The CTE of a copper/zirconium flange is approximately 17 ppm/° C., whereas the CTE of a silicon die is approximately 2.8 ppm/° C. As the die **110** and flange **102D** are heated to solder the die to the flange, the die and flange expand.

[0056] Later, and shown in FIG. 7B, as the die **110** and flange **102D** cool, eutectic solder **114B** suddenly hardens, but the flange and die continued to cool and contract. The eutectic solder **114B** is very hard and not very ductile. Therefore, the contraction of the top surface **702** of the flange **102D** is constrained by the die **110**, which has a much smaller CTE than the flange. As a result, the top surface **702** of the flange **102D** contracts less than the bottom surface **700**, causing the bottom surface to take on a concave shape, which can leave a gap when the flange is mounted to a heat sink.

[0057] To counteract the tendency of the flange **102** to take on a concave shape after soldering, the flange is preferably given a slightly convex shape prior to the soldering. FIG. 7C shows the flange **102** before the die **110** is soldered thereto. The bottom surface **704** of the flange **102** is given a shape, whose convexity (dimension H) is greater than the amount of concavity that would be introduced by soldering. In one embodiment, the bottom surface **704** is convex at least by about 0.0001 inches over the length of the flange. In another embodiment, the bottom surface **704** is convex by between about 0.0005 inches and about 0.0010 inches. This amount can be varied depending on various factors, such as the soldering technique used, the number, size and placement of die soldered to the flange, the length, width and thickness of the flange and the composition of the flange. Conventional flanges are typically about 0.040 or 0.062 inches thick. A flange thickness (dimension G in FIG. 5A) of preferably about 0.125 inches can reduce the amount of deformation caused by the soldering. The bottom surface convexity is preferably imparted by a coining process, although other processes, such as sanding, bending, casting or forging are acceptable.

[0058] FIG. 7D shows the flange **102** after the die **110** has been soldered thereto and both have cooled. The bottom surface **704** preferably has a slightly convex shape. When the flange **102** is mounted to a heat sink, forces applied by mounting screws to the flange (as indicated by arrows **706**

and **708**) flatten the flange against heat sink and creates a good heat-transfer junction between the flange and heat sink.

[0059] As previously noted, the flange **102** includes a generally planar die-attach area **112**, to which the die **110** is soldered, epoxied or otherwise attached. The die-attach area **112** is preferably flat to within about 0.001 inches per inch, and more preferably to within about 0.0005 inches per inch, to facilitate a good eutectic solder connection between the die **110** and the die-attach area. In addition, the die-attach area surface roughness is preferably less than about 30 micro-inches for eutectic soldering. The surface roughness of the bottom of the flange **102** is preferably less than about 64 micro-inches to facilitate making good head-conducting contact with a heat sink. If an adhesive, such as epoxy, is used to attach the die **110** to the die-attach area **112**, the die-attach area is preferably flat to within about 0.005 inches per inch and smooth to within about 64 micro-inches.

[0060] Also as previously noted, the flange **102** includes mounting slots **116** and **118**. Alternatively, the flange **102** can include threaded or unthreaded mounting holes. In these cases, the flange **102** can be mounted to a heat sink or other substrate by bolts or other fasteners extending through these openings. Alternatively, the flange **102** can be soldered to a heat sink or other substrate, obviating the need for mounting slots.

Leads

[0061] As previously noted with reference to FIG. 1, the frame **104** is molded, preferably by injection molding, to the flange **102** and to the leads **106** and **108**. During the molding operation, the frame **104** is molded preferably around the leads **106** and **108**, which extend from outside the frame, through sidewalls of the frame, into the air cavity area. As a result of this molding, the frame adheres to the leads **106** and **108**, although this adhesion is typically imperfect and subject to breakdown due to the heat of soldering and operation of the die. To overcome this problem, each lead **106** and **108** preferably includes one or more lead retention features to secure the lead to the frame **104**.

[0062] One lead retention feature defines at least one hole **310** through each lead, as shown in FIG. 8. As previously noted, the holes **310** are formed in the leads **106** and **108** when the lead frame **300** (FIG. 3) is stamped or etched. Preferably, each lead **106** and **108** includes a plurality of preferably rectangular holes **310** arranged in a line where the frame **104** will contact the lead. During molding, some frame thermoplastic flows into, and then freezes in, the holes **310**, thus mechanically locking the lead **106** or **108** within the frame **104** and preventing the lead from being pulled out of the frame without requiring an adhesive to be added between the lead and the frame. As shown in FIG. 5A, the holes **310** are preferably completely covered by the frame **104**.

[0063] Electrical conductivity of the leads **106** and **108** contributes to the overall performance of the circuit package **100**. The conductivity of a lead **106** or **108** is proportional to a lateral, i.e. approximately perpendicular to the direction of current flow through the lead, cross-sectional area of the lead. Because the holes **310** reduce this cross-sectional area (see section line B-B in FIG. 8), the number, placement, size and shape of the holes can be selected to minimize the loss in effective conductivity of the leads **106** and **108**. Prefer-

ably, the holes **310** reduce the cross-sectional area of the lead at most by about 25%, although this reduction can be greater if the conductivity of the resulting lead meets design criteria.

[0064] Rectangular holes **310** maximize the amount of frame thermoplastic that can freeze and lock the leads **106** and **108**, while minimizing the reduction in conductivity of the leads. The longer dimensions of the rectangular holes **310** are preferably aligned parallel to the direction of current flow through the leads **106** and **108**. Depending on the thickness of the sidewalls of the frame **104**, the holes **310** can be square.

[0065] Another lead retention feature, shown in **FIG. 8**, provides a hooked or bent (hereinafter collectively "hooked") edge **800**, ridge, depression or other structure on or near the end of the lead **106** or **108** that resides within the air cavity area. This structure is not co-planar with the lead. As can be seen in **FIG. 5A**, during molding, some frame thermoplastic freezes in or against an outward-facing portion of this structure, thereby creating a mechanical barrier that prevents the lead **106** from being pulled out of the frame **104**. The hooked edge **800**, ridge or other structure is formed in the leads **106** and **108** when the lead frame **300** (**FIG. 3**) is stamped. Although a hooked edge **800** is the preferred embodiment for this lead retention feature, other shapes can be used. Examples of some acceptable shapes are shown in cross-section in **FIG. 8B** at **800A-F**.

[0066] As previously discussed with reference to **FIG. 1**, the leads **106** and **108** are used to electrically connect the die **110** to a circuit board or the like. The leads **106** and **108** are made of a high-copper alloy (at least 50% copper) to provide good electrical conductivity and to match the CTE of the frame **104**. High-copper leads provide electrical conductivity that is superior to prior art leads, which typically comprise 42% nickel and 55% iron (commonly known as Alloy 42). In addition, the leads **106** and **108** are preferably electroplated with about 100 micro-inches of nickel to form a diffusion barrier layer and about 65 micro-inches of gold to facilitate wirebonding or lead soldering the leads.

[0067] The leads **106** and **108** are preferably made of an alloy of between about 2.1% and about 2.6% iron, between about 0.015% and about 0.15% phosphorus, between about 0.05% and about 0.2% zinc, with the balance copper. Other ratios of these materials are, however, acceptable. The leads **106** and **108** are more preferably made of about 97.5% copper, about 2.35% iron, about 0.3% phosphorus and about 0.12% zinc. Such an alloy is available from Olin Corporation under the UNS designation C19400.

[0068] Many alternative compositions for the leads **106** and **108** are acceptable. One such alternative includes about 99.9% copper and about 0.1% zirconium. Such an alloy is available from Olin Corporation under UNS designation C15100. Other ratios of these materials are, however, acceptable. For example, an alloy made of between about 0.05% and about 0.15% zirconium, with the balance copper, is also acceptable.

[0069] Another alternative composition for the leads **106** and **108** includes between about 1% and about 2% iron, between about 0.01% and about 0.035% phosphorus, between about 0.3% and about 1.3% cobalt, between about 0.1% and about 1% tin and the balance copper. The preferred amount of copper in this composition is 97%. Such an alloy is available from Olin Corporation under UNS designation C19500.

[0070] Another alternative composition for the leads **106** and **108** includes between about 0.3% and about 1.2% iron, between about 0.1% and about 0.4% phosphorus, between about 0.01% and about 0.2% magnesium, and the balance copper. The preferred formulation in this alternative composition is about 0.6% iron, about 0.2% phosphorus, about 0.05% magnesium and about 99% copper. Such an alloy is available from Olin Corporation under UNS designation C19700.

[0071] Another alternative composition for the leads **106** and **108** includes between about 1.7% and about 2.3% tin, between about 0.1% and about 0.4% nickel, up to about 0.15% phosphorus and the balance copper. Such an alloy is available from Mitsubishi Electric Corporation under UNS designation C50710.

[0072] Yet another alternative composition for the leads **106** and **108** includes between about 0.05% and about 1.5% iron, between about 0.025% and about 0.04% phosphorus and the balance copper. Such an alloy is available from Kobe Steel, Ltd. under UNS designation C19210.

[0073] Yet another alternative composition for the leads **106** and **108** includes between about 0.5% and about 0.15% iron, between about 0.5% and about 1.5% tin, between about 0.01% and about 0.035% phosphorus and the balance copper. Such an alloy is available from Mitsubishi Shinto Company, Ltd. under UNS designation C19520.

[0074] Another alternative composition for the leads **106** and **108** includes between about 0.15% and about 0.4% chromium, between about 0.01% and about 0.4% titanium, between about 0.02% and about 0.07% silicon and the balance copper. Such an alloy is available from Wieland Werke under UNS designation C18070.

[0075] Yet another alternative composition for the leads **106** and **108** includes between about 0.8% and about 1.8% nickel, between about 0.15% and about 0.35% silicon, between about 0.01% and about 0.05% phosphorus and the balance copper. Such an alloy is available from Poong San Metal Corporation under UNS designation C19010.

[0076] Another alternative composition for the leads **106** and **108** includes between about 2.0% and about 4.8% nickel, between about 0.2% and about 1.4% silicon, between about 0.05% and about 0.45% magnesium and the balance copper. The preferred formulation in this alternative composition is about 3.0% nickel, about 0.65% silicon, about 0.15% magnesium and about 96.2% copper. Such an alloy is available from Olin Corporation under UNS designation C70250.

[0077] Yet another alternative composition for the leads **106** and **108** includes between about 0.3% and about 0.4% chromium, between about 0.2% and about 0.3% tin, between about 0.15% and about 0.25% zinc and the balance copper. Such an alloy is available from Furukawa Electric under UNS designation EFTEC-64T.

[0078] Another alternative composition for the leads **106** and **108** includes between about 2.7% and about 3.7% nickel, between about 0.2% and about 1.2% silicon, between about 0.1% and about 0.5% zinc and the balance copper. Such an alloy is available from Kobe Steel, Ltd. under UNS designation KLF-25.

[0079] Yet another alternative composition for the leads **106** and **108** includes between about 1.9% and about 2.9% nickel, between about 0.2% and about 0.6% silicon, between about 0.1% and about 0.2% phosphorus and the balance copper. Such an alloy is available from Mitsubishi Electric Corporation under UNS designation MF224.

Frame

[0080] As noted above, with respect to **FIG. 5A**, the frame **104** is made of injection molded thermoplastic and is molded to the flange **102** and to the leads **106** and **108**. The material of the flange **102** preferably includes a liquid crystal polymer (LCP) that can withstand die-attach temperatures (280-330° C. for AuSn soldering or 390-420° C. for AuSi soldering). Conventional LCPs melt at temperatures between about 300° C. and about 330° C. The frame **104** preferably includes base resins and compounds to raise its melting temperature, adjust its coefficient of thermal expansion (CTE) and reduce its permeability to moisture. For convenience, the material of the frame **104**, including the resins and compounds, is referred to here herein as a “thermoplastic compound” or “frame material.”

[0081] An example of an acceptable resin is one that includes para-hydroxybenzoic acid, bisphenol and phthalic acid. Another acceptable formulation includes a copolymer of p-hydroxybenzoic acid (HBA) and 6-hydroxy-2-naphthoic acid (HNA). Other acceptable formulations include terpolymers of HBA, 4-4-bisphenol (BP) and terephthalic acid (TA).

[0082] **FIG. 9** is a schematic cross-section diagram of the frame **104** showing some of the compounds in the thermoplastic compound. Filler particles are preferably added to the LCP to modify its CTE to more closely match the CTE of the leads **106** and **108** (approximately 17 ppm/° C.) and to disrupt the anisotropy of the thermoplastic compound in the frame **102**. The CTE of the frame material is preferably adjusted to be within about 60% of the CTE of the leads **106** and **108**. Spherical balls of minerals **900**, such as talc, preferably about 2 to 3 microns in diameter, can be added to the LCP at concentrations of about 30% to about 40%. Such a composite has a CTE of about 7 ppm/° C. to 22 ppm/° C.

[0083] Graphite is preferably added to the LCP to reduce moisture infiltration. This graphite is preferably in the form of generally planar graphite flakes **904** (shown edge-on in **FIG. 9**), however other forms of graphite, such as balls or chunks, are also acceptable. In addition, the graphite flakes **904** can warp somewhat during injection, etc., without significantly altering their effectiveness. The term “generally planar graphite flakes” includes such flakes that have been deformed.

[0084] The graphite flakes **904** preferably form layers, preferably roughly parallel to exterior surfaces of the frame **104**, thus creating tortuous paths **906** for moisture infiltration. Even if the layers are not parallel to the exterior surfaces, the presence of the graphite inhibits moisture infiltration. The graphite flakes **904** also adjust the CTE of the LCP to more closely match the copper alloy of the leads **106** and **108**. The frame material contains between about 10% and about 70% graphite flakes, preferably between about 40% and about 50%.

[0085] As an alternative to graphite flakes, glass fiber **1202** can be added to the LCP to increase rigidity and adjust

CPE of the resulting thermoplastic compound. In this embodiment, the frame material preferably contains between about 30% and about 50% glass fiber.

[0086] As another alternative, or in addition, to the graphite flakes, other compounds can be added to the LCP, such as iron powder based absorbers, molecular sieve filters (zeolites) and calcium oxide (CaO). Suitable zeolites are available from Sud-Chemie, Inc.

[0087] The frame material is preferably pre-dried, preferably to less than about 0.008% moisture content, before injection molding. In addition, injection times should be kept short, preferably less than about 0.2 seconds. Injection shot sizes should be kept small, preferably less than about 2 grams, to minimize residence time of the thermoplastic compound in the injection molder barrel. A gate at the injection site preferably restricts flow of the thermoplastic compound, thereby increasing shear on the thermoplastic compound, to orient the polymer chains and the graphite flakes **904**. The thermoplastic compound is preferably injected at a corner of the frame **104** or between the leads **106** and **108**. To minimize the amount of stress in the resulting frame, a minimum mold temperature of about 250° F. is preferably maintained during the molding operation.

[0088] A moisture barrier film is preferably applied to the exterior surfaces of the frame **104** to further reduce moisture infiltration. Alternatively, the film can be applied to the interior of the frame **104**. Acceptable materials include amine-based epoxies available from PPG Industries under the trade name Bairocade, polymer-Al films and polymer-ceramic films.

Seal

[0089] The frame retention feature **500** (**FIG. 5A**) and the lead retention feature **800** (**FIG. 8A**) provide good mechanical connections that inhibit infiltration of moisture and atmospheric gases. In addition, the frame **104** preferably includes constituents and an exterior or interior film to reduce this infiltration. To further reduce infiltration, as illustrated in **FIG. 10**, seals **1000** and **1002** are preferably applied inside the frame **104** along edges of the frame **104**, where the frame meets the leads **106** and **108** and where the frame meets the flange **102**. As shown in cross-section in **FIG. 11A**, seal **1002** is effective to prevent infiltration between the flange **102** and the frame **104** and to prevent infiltration between the frame **104** and the lead **108**. Alternatively, as shown in **FIG. 11B**, two seals, **1002A** and **1002B** can be used instead of the one seal **1002**.

[0090] To promote good adhesion of the sealant to the frame material, the frame material is preferably cleaned prior to application of the sealant. Plasma cleaning, as is well-known in the art, where oxygen is the predominant medium produces acceptable results. Alternatively, the frame material can be cleaned with solvents or by etching. A 0.008 inch inside-diameter (ID) needle is preferably used to dispense material for seal **1000**, and a 0.010 inch ID needle is preferably used to dispense material for seal **1002**. Other needle sizes can, of course, be used, depending on the size of the desired bead. To minimize air bubbles in the sealant, a positive displacement, auger pump is used to pump the sealant to the needles.

[0091] The sealant material preferably has a viscosity between about 58 Pa.s and about 128 Pa.s at a shear rate of

about 0.95 per second, and a viscosity between about 12 Pa.s and about 30 Pa.s at a shear rate of about 9.5 per second. FIG. 12 contains a graph 1200 showing a preferred relationship between viscosity and shear rate. A low viscosity is preferred at high shear rates, so the material can be dispensed quickly. However, a high viscosity is preferred at low shear rates, so, once the material has been dispensed, it does not run.

[0092] The material preferably has a cason viscosity between about 3 Pa.s and about 7.4 Pa.s. The material's thixotropic index is preferably between about 3.5 and about 4.6.

[0093] Suitable materials for the seals 1000 and 1002 include epoxies, silicones and conformal coatings. A suitable sealant includes between about 40% and about 60% solvent (such as 2-butyl acetate) and between about 40% and about 60% epoxy or silicone resin. The epoxy can be, for example, bis-phenol A or a cyclic aliphatic epoxide resin. Suitable hardeners include amine hardeners. Alternatively, the seal can be made of Paralyne D or Parylene HT, available from Cookson Electronics.

Lid

[0094] The lid 200 is attached to the frame 104 after the die 110 has been attached to the flange 102 and electrically bonded to the leads 106 and 108. A suitable lid 200 is shown in FIGS. 13A and 13B. The lid 200 is preferably ultrasonically welded to the frame 104, preferably using a welding signal having a frequency between about 50 kHz and about 60 kHz and an amplitude less than about 100 microns (more preferably less than 60 microns). Alternatively, the lid 200 can be laser welded or heat welded to the frame 104.

[0095] Conventional ultrasonic plastic welding techniques have not been used to seal lids to circuit packages, because these conventional techniques use lower welding frequencies, which result in higher amplitudes that can damage wirebond assemblies mounted in circuit packages. The higher welding frequencies of the present invention result in lower amplitudes and, consequently, do not damage wirebond assemblies. Conventionally, lids are attached to circuit packages with epoxy adhesives. Advantageously, ultrasonic welding can be accomplished in much less time (approximately 250 mSec.) than epoxy cure times (apx. 2 hours).

[0096] There is preferably an interference fit between the lid 200 and the frame 104, so portions of both the lid and frame melt and fuse together during the ultrasonic welding. As shown in the cross-section in FIG. 13B, the lid 200 preferably includes a lip 1300 that melts and fuses with the frame 104. The lid 200 is preferably made of the same material as the frame 104, as described above. In addition, a moisture barrier film is preferably applied to the lid 200, as described above with respect to the frame 104.

Manufacturing Details

[0097] Details of the flange 102, frame 104, leads 106 and 108 and lid 200 of the circuit package 100, including materials and processes used to fabricate these parts, have

been described in detail above. FIG. 14 contains a simplified flowchart illustrating a process, by which the circuit package 100 can be made and used.

[0098] At 1400, a first high-copper alloy is made for the leads 106 and 108. At 1402, lead frames are fabricated from the first high-copper alloy made at 1400. At 1404, holes 310 are punched, etched or otherwise made in lead frame 300 to create one of the lead retention features. At 1406, the ends of the leads 106 and 108 are curled, bent, stamped or etched on the lead frame 300 to create the other lead retention feature 800.

[0099] At 1408, a second high-copper alloy is made for the flange 102. At 1410, the flange 102 is fabricated from the second high-copper alloy made at 1408. At 1412, the frame retention feature 500 is coined in the flange 102 by a progressive stamping process. Optionally, at 1414, the bottom of the flange 102 is lapped. At 1416, the bottom of the flange 102 is made convex.

[0100] At 1418, graphite flakes, talc and/or glass fiber is added to liquid crystal polymer to make frame material. At 1420, the frame material is dried. At 1422, the frame 104 is molded to the flange 102 and the leads 106 and 108.

[0101] At 1424, the interior of the frame 104 and flange 102, i.e. the air cavity area, is cleaned. At 1426, the sealant is applied to seal the boundaries between the frame 104 and the flange 102 and between the frame and the leads 106 and 108.

[0102] At 1428, the die 110 is attached to the flange 102. At 1430, the die 110 is ultrasonically wirebonded to the leads 106 and 108. At 1432, the lid 200 is ultrasonically welded to the frame 104.

[0103] While the invention has been described with reference to a preferred embodiment, those skilled in the art will understand and appreciate that variations can be made while still remaining within the spirit and scope of the present invention, as described in the appended claims. For example, lower power die can be attached to the flange with epoxy or other adhesives, rather than being soldered thereto. In addition, as is well known in the art, alloys typically contain small amounts of impurities, so constituents described herein do not necessarily total 100%.

[0104] Although the frame retention feature 500 and the convexity H of the flange bottom have been described in the context of a high-copper flange 102, these innovations are also applicable to conventional flanges and flanges made of other materials. Although the lead retention features 310, 800 and their respective alternatives have been described in the context of high-copper leads, these innovations are also applicable to conventional leads and leads made of other materials. Although the frame material has been described in the context of a circuit package 100, this material can be advantageously used in other contexts, such as those that require a material that can withstand high temperatures. Examples of other applications of the frame material include high-temperature laminates in printed circuit boards (PCBs) and sockets for electronic components, cables, PCBs and the like.

What is claimed is:

1. A method for enclosing a circuit package, comprising ultrasonically welding a thermoplastic material lid to a thermoplastic material frame of the circuit package using a welding signal having a frequency between about 50 KHz and about 60 KHz and an amplitude less than about 100 microns.

2. The method of claim 1, wherein the amplitude is less than about 60 microns.

3. A method for enclosing a circuit package, comprising laser welding a thermoplastic material lid to a thermoplastic material frame of the circuit package.

4. A method for enclosing a circuit package, comprising thermal welding a thermoplastic material lid to a thermoplastic material frame of the circuit package.

* * * * *